



E-CNC 185 CYLINDER HEADS
For Small-Block Chevrolet V8 Engines
Part #s 79889 & 79899
INSTALLATION INSTRUCTIONS

PLEASE study these instructions carefully before beginning this installation. Most installations can be accomplished with common tools and procedures. However, you should be familiar with and comfortable working on your vehicle. If you do not feel comfortable performing this installation, it is recommended to have the installation completed by a qualified mechanic. If you have any questions, please call our **Technical Hotline at: 1-800-416-8628**, 7:00 am - 5:00 pm, Pacific Standard Time, Monday through Friday.

IMPORTANT NOTE: Proper installation is the responsibility of the installer. Improper installation will void your warranty and may result in poor performance and engine or vehicle damage.

DESCRIPTION: Edelbrock E-CNC 185 Cylinder Heads are designed for street/strip high performance use on non-emissions vehicles and are interchangeable with original equipment cylinder heads (uses '86 and earlier intake & valve cover bolt patterns, not compatible with centerbolt covers or Vortec intake manifolds). These heads DO NOT retain an exhaust crossover passage, and will not work on any vehicle requiring EGR (Exhaust Gas Recirculation) equipment. E-CNC cylinder heads feature intake and exhaust ports that are fully CNC machined for maximum performance while retaining the high port velocity needed for low speed throttle response. These cylinder heads have been designed for maximum performance when matched with Edelbrock intake manifolds, camshafts, carburetors or additional recommended performance parts.

Complete cylinder heads are assembled with the following components: Stainless steel, one-piece, swirl-polished intake and exhaust valves with under-cut stems for increased flow; 2-ring positive-oil-control seals; 3/8" rocker arm studs and 5/16" guide plates; Hardened steel valve spring locators; Edelbrock Sure-Seat Valve Springs, retainers, and valve keepers.

NOTE: Complete cylinder heads are assembled and prepared for installation right out of the box. **Bare cylinder heads will have valve guides and seats installed, but will require final guide sizing and a valve job to match the valves you will be using.**

BEFORE BEGINNING INSTALLATION

IMPORTANT NOTES: READ BEFORE BEGINNING INSTALLATION!

For a successful installation, the Edelbrock E-CNC 185 Cylinder Heads require some components other than original equipment parts. To complete your installation, you will need the following items:

- Head gaskets; Edelbrock #7310
- Intake manifold gaskets; Edelbrock #7201
- Exhaust gaskets; Edelbrock #7204
- Valve Cover gaskets; Edelbrock #7549

NOTE: Edelbrock Cylinder Head Gasket Set #7361 may also be used in place of individual gaskets. This set contains all gaskets necessary for cylinder head installation, including cylinder head, intake (requires valley cover plate), exhaust, and valve cover gaskets.

- Edelbrock head bolt kit #8550 (see instructions below)
- 14mm x 3/4" reach x 5/8" hex, gasketed spark plugs (heat range to be determined by specific application)
- Adjustable rocker arm assembly (Premium roller rockers recommended)
- +.100" longer-than-stock hardened pushrods; Edelbrock #9629 (May be required when using stock-type rockers, adjustable roller rockers can generally use stock length, hardened steel)

CHECKING VALVE-TO-PISTON CLEARANCE: Prior to installation, it is highly recommended that valve-to-piston clearances are checked and corrected to minimum specs, if necessary. Minimum intake valve clearance should be .100". Minimum exhaust valve clearance should be .110". E-CNC 185 cylinder heads are designed for use with flat-top pistons.

PISTON-TO-CYLINDER HEAD CLEARANCE: Edelbrock cylinder heads are designed for use with flat-top pistons. The use of domed pistons requires that piston-to-head clearance be checked before installation. Recommended minimum piston-to-head clearance is .050".

VALVE-TO-BORE CLEARANCE: Edelbrock cylinder heads are designed to be used on engines with a minimum bore size of 4.000". If used on engines with a bore size less than 4.000" (307, 305, 283, 267, 265, & 262 c.i.d.), do not use a camshaft with more than .450" lift or the valves may hit the cylinder bores.

ROCKER GEOMETRY: Rocker geometry should be checked, making sure that the contact point of the roller (or pad on a stock rocker arm) remains properly on the valve tip and does not roll off the edge. Visual inspection of the rockers, valve springs, retainers, and pushrods should be made to ensure that none of these components come into improper contact with each other. If problems with valve train geometry occur, changes such as pushrod length may have to be made.

ACCESSORIES

Although Edelbrock E-CNC cylinder heads will accept OEM components (rocker arms, valve covers, intake manifold, head bolts, etc.), we highly recommend that premium quality hardware be used with your new heads.

- **Intake Manifold:** Although stock intake manifolds will fit, the Edelbrock E-CNC Cylinder Heads are matched in size and operating range with Edelbrock Performer RPM intake manifolds. For best results, use stock or Edelbrock intake manifolds listed as stock replacement parts for the year and model of your vehicle. Use recommended intake manifold gaskets. **DO NOT** use cork or rubber end seals supplied with gaskets; instead, use RTV Silicone sealer. Apply a 1/4" bead along front and rear of block, overlapping gaskets at the four corners. Torque manifold bolts to 25 ft./lbs.
- **Head Bolts or Studs:** High quality head studs or head bolts with hardened washers must be used to prevent galling of the aluminum bolt bosses. We recommend Edelbrock Head Bolt Kit #8550. OEM head bolts may be used if they meet these specs for length: 1-3/4" (short bolts); 3" (medium bolts); 3-13/16" (long bolts). Shorter bolts do not have enough thread engagement for use with hardened washers. With OEM bolts, use hardened GM #10051155, ARP #200-8511, or equivalent washers. Bolt threads, underside of bolt heads, and washers should be lubricated with an oil/moly mix prior to installation and torquing.
- **Exhaust Headers:** Any header or manifold designed for original equipment heads will fit Edelbrock Cylinder Heads. Exhaust ports are CNC profiled to match Edelbrock #7204 exhaust gaskets which are recommended for this application. Some applications may require the use of straight plug heads, due to header tube interference which can be caused by angle plug heads.
- **Valve Springs:** Complete cylinder heads are assembled with valve springs that are compatible with Edelbrock Performer, Performer RPM and Performer RPM Hydraulic Roller camshafts. If any other camshaft is used, check with the camshaft manufacturer for recommended valve spring pressures.
- **Valve Covers:** Edelbrock cylinder heads accept stock valve covers for the year and model for which they are listed. They also accept Edelbrock valve covers #4449, #4649, #4249 or #4248.
- **Rocker Arms:** Some rocker arms, particularly stock non-adjustable style, will require +.100" longer-than-stock hardened pushrods (Edelbrock #9629) to maintain proper geometry. The valve springs supplied will accommodate valve lifts up to .575", which is much higher than stock rocker arms will allow. Long-slot stamped or roller rocker arms will be required if your camshaft has more than .480" lift.
NOTE: You must check retainer-to-rocker clearance prior to starting engine.
CAUTION: Some Chevrolet V8 cylinder heads are factory equipped with "self-aligning" rocker arms. These rocker arms have a stamped recess on the valve tip end to guide the rocker arm on the valve stem which allows the rocker arm to guide the pushrod. Edelbrock cylinder heads are equipped with hardened pushrod guideplates. Therefore, non-self-aligning, stamped (i.e., Crane #11801-16, Sealed Power #R-865R, Pioneer-Barnes #818001 etc.), or non-self-aligning roller rocker arms must be used with this cylinder head.
- **Spark Plugs:** Use 14mm x 3/4" reach gasketed spark plugs. Heat range may vary by application, but we recommend Champion RC-12YC (or equivalent) for most applications. Champion RC-12YC are 1/4" shorter than "N" series plugs and may be required for header clearance. Use anti-seize on the plug threads to prevent galling in the cylinder head, and torque to 10 ft./lbs.
NOTE: Do not overtighten sparkplugs!

INSTALLATION PROCEDURE

Installation is the same as for original equipment cylinder heads. Consult service manual for specific procedures, if necessary. Use Edelbrock head gasket #7310. #7310 has a flattened steel O-ring around each bore and will provide an excellent, long lasting seal. However, it will compress the aluminum and you must use #7310 for subsequent gasket changes to get a good seal.

NOTE: YOU MUST DRILL "STEAM HOLES" IN CYLINDER HEADS FOR 400 ENGINES (See Figure 1).

Drill three .125" holes in each head using 400 c.i.d. head gasket as a guide. **DRILL ONLY THE THREE LOWER STEAM HOLES** (closest to the spark plugs) as indicated. Drill straight into the head (90° from the deck) until the drill breaks through into the water jacket (about 9/16").

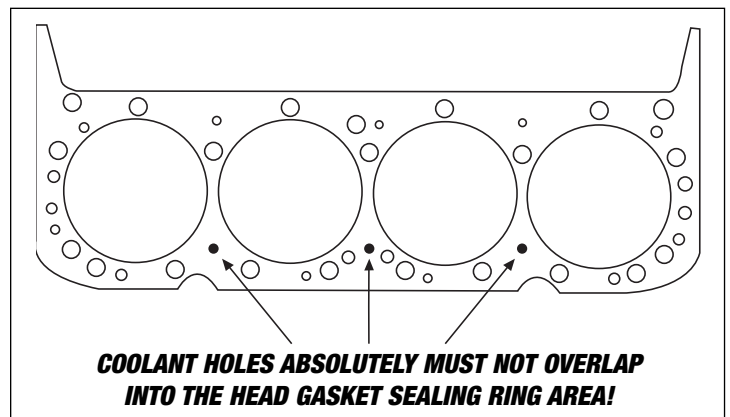

Figure 1 - Steam Hole Locations (400 C.I.D. Engines ONLY)

IMPORTANT NOTICE

These cylinder heads are equipped with valve spring cups. Due to the diameter of the valve spring cups, it may be necessary to clear the headbolt washer #1. The #1 headbolt is called out in your instruction sheet (see figure1). The headbolt washer in the #1 location is the only washer that may require clearancing. This will allow the headbolt washers to seat properly to the cylinder head (See Figure 2). This can also be accomplished by removing the valve spring and cup. Then position washer prior to installation of cylinder head.



Figure 2 - #1 Head Bolt Washer

Be sure that the surface of the block and the surface of the head is thoroughly cleaned to remove any oily film before installation. Use alcohol or lacquer thinner on a lint-free rag to clean. Apply RTV silicone or ARP thread sealer to head bolt threads, and apply engine oil or ARP lubricant to the head bolt washers and underside of bolt heads. Torque bolts to 65 ft./lbs. in three steps (40-55-65), following the factory tightening sequence (See Figure 3). Check to make sure engine has proper grounds to chassis. When pouring coolant back in the radiator make sure to use atleast a 50/50 mixture of coolant to water. A re-torque is recommended after initial start-up and cool-down (allow 2-3 hours for adequate cooling).

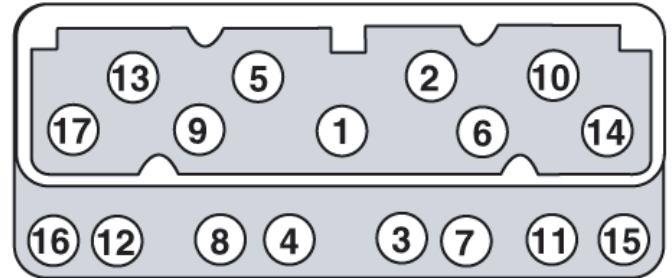

**Figure 3 - Cylinder Head Bolt Torque Sequence
Torque Bolts to 65 ft./lbs. in Three Steps (40-55-65)**

Other Assembly Tips: When installing the sparkplugs and exhaust manifolds, be sure to use a high temperature anti-seize compound on the threads to reduce the possibility of thread damage in the future.

NOTE: Torque sparkplugs to 10 ft./lbs. Do not overtighten sparkplugs! If short reach plug is used, poor performance and possible engine damage may occur.

PUSHROD GUIDE PLATE ALIGNMENT

Complete Edelbrock cylinder heads are sold with the pushrod guideplates and rocker studs installed, but they will require checking for proper valve train alignment and pushrod clearance before operating engine. The pushrod guideplates are attached to the cylinder heads with two (each) rocker studs. There is enough clearance around the stud holes to adjust the guideplates for optimum alignment of your valve train components (See Figure 4).

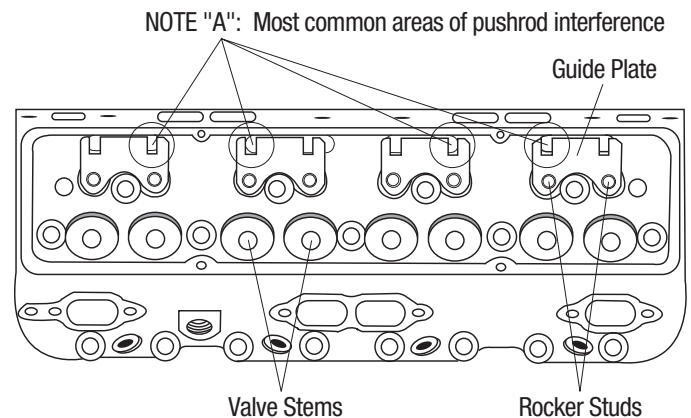

Figure 4 - Pushrod Guide Plate Clearance

1. After the heads have been bolted on your engine and torqued to specs, install your pushrods, rocker arms, and rocker arm adjusting nuts then check pushrod-to-cylinder head clearance.

NOTE: YOU MUST CHECK TO ENSURE THAT THERE IS CLEARANCE BETWEEN THE PUSHRODS AND THE CYLINDER HEADS (.005" min.) (See Note "A", Figure 4).

2. If adequate clearance exists between pushrod and head, slowly turn engine over through at least two revolutions while watching pushrod. Make sure that pushrod does not rub on the head either at full lift or when the valve is seated closed.
3. If pushrod rubs on the cylinder head, remove rocker arms, loosen the rocker studs and move the guideplate as needed to provide clearance.
4. After checking all pushrods for proper clearance, ensure that the tip of the rocker arm is making adequate contact with the top of the valve stem.
5. Carefully re-torque to 45 ft./lbs. any rocker studs that were loosened. Check alignment again to be sure that the guideplates did not move while torquing the studs.

SPECIFICATIONS

Bare Cylinder Heads:	#79889
Complete Cylinder Heads:	#79899
Head bolt torque:65 ft./lbs. (in steps of 40-55-65)
Rocker stud torque:45 ft./lbs.
Intake Gaskets:	Edelbrock #7201
Spark Plug Position:	Straight
Combustion chamber volume:64cc
Deck thickness:	9/16"
Valve Seats:Hardened, interlocking (Compatible with unleaded fuels)
Valve Size:	Intake - 2.02", Exhaust - 1.60"
Valve Spring Diameter:	1.45"
Valve Spring Installed Height:	1.800"
Valve Spring Seat Pressure:	120 lbs.
Valve Spring Seat Pressure @ .581" Lift:	320 lbs.
Max. Valve Lift:	0.575"



Edelbrock LLC • 2700 California St. • Torrance, CA 90503
Tech-Line: 1-800-416-8628 • Office Line: 310-781-2222