



VICTOR PRO-PORT LSR CYLINDER HEADS
For GM Gen III/IV Engines
Part #770469
INSTALLATION INSTRUCTIONS

PLEASE study these instructions carefully before beginning this installation. If you do not feel comfortable performing this installation, it is recommended to have the installation completed by a qualified engine builder. If you have any questions, please call our **Technical Hotline at: 1-800-416-8628**, 7:00 am - 5:00 pm, Pacific Standard Time, Monday through Friday.

IMPORTANT NOTE: Proper installation is the responsibility of the installer. Improper installation will void your warranty and may result in poor performance and engine or vehicle damage.

DESCRIPTION: The Victor Pro-Port LSR cylinder head is designed for all out racing applications on GM Gen III/IV blocks. While compatible with factory LS series blocks, these heads have been designed specifically to take advantage of the LSX racing block. Featuring a true canted valve design, these heads have the potential to produce unprecedented levels of power from the latest generation of GM engines. Additional cooling provisions have been included to precisely control cylinder temperatures in extreme racing environments. These heads also feature provisions for additional head bolts to improve sealing and gasket retention (**Note: Provisions for these extra bolts are found only on aftermarket race blocks.**) These heads have small ports and chambers that will require professional porting prior to installation. Valve guides are included but not installed, and the seat bores are undersized and shallow. Heli-coil thread inserts for valvetrain retention are also included but not installed.

NOTE: Prior to standard machining and heat treating procedures, this cylinder head was subjected to a process known as Hot Isostatic Pressing (HIP). During this process the casting is exposed to heat in excess of 900° F and inert gas pressures of nearly 30,000 psi. This combination of heat and pressure eliminates any gas pores remaining from when the head was originally cast. By elevating the material density of the cylinder head to nearly the level of billet aluminum, significantly increased durability and longevity under extreme conditions is achieved.

IMPORTANT NOTES: READ BEFORE BEGINNING INSTALLATION!

For a successful installation, Victor LSR Cylinder Heads require several specialized components. To complete your installation, you will need the following items:

- Head Gaskets: GM Performance Parts #19170419 (includes extra head bolt holes).
- Intake Manifold Gaskets: Currently in development by Edelbrock, custom gaskets or other sealing solution will need to be used until application specific gaskets are available.
- Exhaust gaskets: Fel-Pro #1440 or equivalent.
- Head Bolts/Studs: High performance head studs/bolts with hardened washers must be used for the primary head bolt locations; the additional LSX provisions will require 8mm x 1.25 studs and/or bolts. These can be special ordered through ARP.
- Valve Covers: Standard SB2.2 valve cover such as GM#12480006.
- Valve Cover Gaskets: Fel-Pro #1655-1.
- Valves: The valve guides supplied are sized for 5/16" stems on the intake, and 11/32" on the exhaust. Reaming guides to the desired tolerance will be required prior to installation.
- Spark Plugs: 14mm x 3/4" reach x 5/8" hex, gasketed seal (heat range to be determined by specific application).
- Shaft Mounted Rocker Assembly: Jesel and T&D have produced application specific rockers for this head.
- Pistons: the unique chamber and valve angle configuration of this head will require pistons shaped to match. Check with your preferred piston manufacturer for specific recommendations.
- Valve Seats: the seat bores of this head are left deliberately undersized to accommodate a variety of seat diameters.



VICTOR PRO-PORT LSR CYLINDER HEADS

For GM Gen III/IV Engines

Part #770469

INSTALLATION INSTRUCTIONS

IMPORTANT NOTES CONTINUED:

CHECKING ENGINE CLEARANCES: As with any competition engine build, it is highly recommended that valve-to-piston clearances are checked prior to installation and corrected to minimum specs, if necessary. Minimum intake valve clearance should be .080". Minimum exhaust valve clearance should be .110". The point of minimum intake valve to piston clearance will usually occur somewhere between 5° and 20° After Top Dead Center during valve overlap. The point of minimum exhaust valve to piston clearance will usually occur 20° to 5° Before Top Dead Center during valve overlap. Some pistons may require notching depending upon the valves selected for your application. Also make sure that there is adequate clearance between the valves and the cylinder wall, as well as the rocker arms to the valve cover and the rocker arm to the valve cover rail (intake only).

REQUIRED MACHINE WORK: The intake and exhaust ports as supplied are deliberately undersized to allow sizing and shaping to the preference of the head porter. The valve seat provisions are also

undersized (2.093" intake and 1.593" exhaust from the factory) and can be machined out to accept a maximum valve size of 2.25" on the intake and 1.68" on the exhaust (Note that these values represent individual maximums, those sizes cannot be used together on the same head). The valve seats can be sunk into the head by up to .250" in order to increase chamber volume. The valve guide bores have already been finished to .500" and the supplied guides simply need to be installed.

COOLING REQUIREMENTS: Numerous water holes are cast and/or drilled in this head. Two 1/4" NPT threaded holes are present below the intake flange in place of the OEM hard line, and a 3/4" NPT threaded hole is provided on each end of the head to allow for a variety of cooling solutions. Any hole that is not plumbed, must be plugged. There are also a series of raised pads located directly below the exhaust flange. Drilling a hole concentric to the as-cast pad will break into the water jacket and allows for forced cooling of individual cylinders when needed.

ACCESSORIES

We highly recommend that premium quality hardware be used with your new heads.

- **HEAD BOLTS OR STUDS:** High quality M11 and M8 head studs or head bolts with hardened washers must be used to prevent galling of the aluminum bolt bosses. **See Figure 1** for the cylinder head bolt tightening sequence. Bolt threads, underside of bolt heads, and washers should be lubricated with an oil/moly mix prior to installation and torquing. Apply liquid Teflon PST or suitable thread sealant on any bolt threads that go into coolant passages. Because factory bolts are a torque-to-yield type fastener, the stock head bolts **CANNOT** be re-used.

NOTE: This head has provisions for eight (8) auxiliary fasteners per head. These provisions are located adjacent to each exhaust port and directly below each intake port. The LSX block has been tapped for 8mm x 1.25 threads on the exhaust side, while the intake holes are smooth and must be accessed from the engine valley. For ease of installation, Edelbrock recommends threading studs into the provisions on the intake side of the cylinder head before installing them on the block. Apply red Loctite to the exposed threads, then install washers and lock nuts.

- **GASKETS:** Any head gasket designed for use with the Gen III/IV engine family will work with the LSR cylinder head. GM #19170419 or equivalent will allow the use of the additional head bolts on the LSX blocks.

- **ROCKER ASSEMBLIES:** Shaft mounted rocker arms are required. Edelbrock recommends the use of Jesel or T&D rocker shaft assemblies. Eight (8) 7/16"-14 heli-coils have been supplied to ensure the stability of the rocker system. These will need to be installed by the engine builder. Significant thread depth has been added to these holes to improve bolt retention and the longevity of valvetrain components under the extreme conditions generated in a racing environment.

- **PISTONS:** The unique chamber and valve placement of the LSR cylinder head will require custom pistons. The valve angles used on this head are 8.7° by 3.2° cant intake and 7.0° by 2.0° cant exhaust. Check with your preferred piston manufacturer to see if they carry an application specific part number.

- **INTAKE MANIFOLD:** Edelbrock does not currently offer a cast aluminum manifold for this head.

- **EXHAUST HEADERS:** Although the Victor LSR cylinder head retains the stock exhaust flange design, aftermarket tubular headers are strongly recommended. The flange has been raised 7/8" relative to stock. Use Fel-Pro gasket #1440 for round port exits up to 1.90" in diameter.

VALVE COVERS: Any valve cover for the SB2.2, such as GM #12480006, will match the bolt pattern of this head and seal correctly.



VICTOR PRO-PORT LSR CYLINDER HEADS

For GM Gen III/IV Engines

Part #770469

INSTALLATION INSTRUCTIONS

ACCESSORIES CONTINUED:

- SPARK PLUGS:** Use 14mm x 3/4" reach gasketed spark plugs with a 5/8" hex. Heat range for competition engines will vary by application. Use anti-seize compound on the plug threads to prevent galling in the cylinder head, and torque to the spark plug manufacturers specification for aluminum heads; usually 10 ft./lbs. **DO NOT OVER TIGHTEN** Please note that the #1 & #8 cylinder spark plug locations are particularly difficult to access and may require a custom tool or minor modification to the header tubes and/or flange.
- VALVES AND VALVE SPRINGS:** Edelbrock Victor LSR cylinder heads will accept an intake valve with a diameter up to 2.25" and an exhaust valve diameter up to 1.68". The supplied valve guides are designed to work with an intake valve stem diameter of 5/16" and exhaust valve stem diameter of 11/32". Length will need to be determined by the engine builder once the valve seats have been installed in their desired location. These cylinder heads are equipped with a 1.780" valve spring pocket diameter. Edelbrock strongly recommends the use of a hardened steel cup or shim below the valve spring to prevent damage to the head. Refer to cam manufacturer for recommended spring pressures

Lubricants: For added performance and protection, we recommend using Edelbrock performance lubricants.

Engine Oils

High Performance Synthetic	10w40 w/Zinc	P/N 1072
High Performance Synthetic	5w30 CAT Safe	P/N 1071
High Performance Petroleum	10w40 w/Zinc	P/N 1073

Or supplement your favorite brand of engine oil

Zinc Additive	-	P/N 1074
---------------	---	----------

Protect your brand new engine

High Performance Break-In Oil	SAE 30	P/N 1070
Engine Assembly Lube	-	P/N 1075

TORQUE SEQUENCE:

The following torque sequence is specific to GM LSX race blocks. Early model Gen III blocks (pre-2003) or LSX style blocks made by other manufacturers may use a slightly different sequence.

Following the sequence shown to the left, install all 23 bolts and torque to the initial stage shown below. Follow by torquing all 23 bolts to the second stage, lastly torque bolts 1-10 to stage 3.

NOTE: The image to the left shows the cylinder head looking up from the deck.

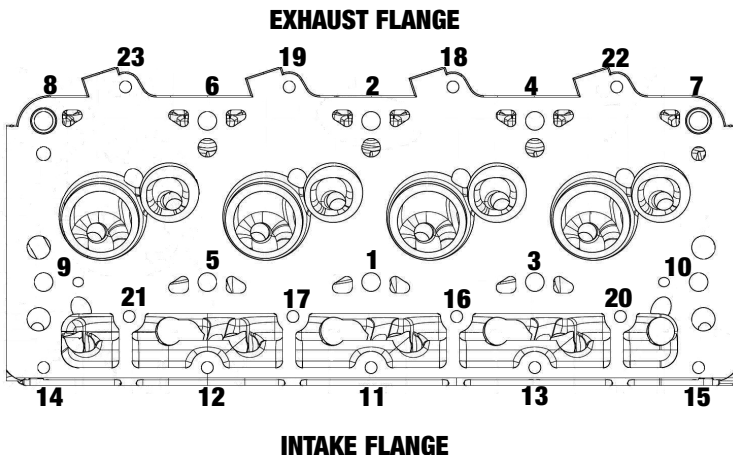

Bolts	Stages (ft. lb.)	Final Torque
1-10 (M11)	35 - 50 - 70	70 ft. lb.
11-15 (M8)	15 - 22	22 ft. lb.
16-23 (M8)	12 - 18	18 ft. lb.

Edelbrock, LLC • 2700 California St. • Torrance, CA 90503
Tech-Line: 1-800-416-8628