



12-Volt 10-lb./15-lb. Nitrous Bottle Heater

Catalog # 72700

INSTALLATION INSTRUCTIONS

PLEASE study these instructions carefully before beginning this installation. If you have any questions, please contact our **Technical Hotline at: (800) 416-8628** from 7 am - 5 pm, Monday through Friday, Pacific Standard Time or e-mail us at **Edelbrock@Edelbrock.com**.

IMPORTANT NOTE:

Proper installation is the responsibility of the installer. Improper installation will void warranty and may result in poor performance and engine or vehicle damage.

FEATURES:

- Durable, Long-Lasting Heating Element
- Velcro® Straps for Easy Installation
- Dual Thermostat Cartridges for Reliability
- All Electrical Hardware Included

INSTALLATION INSTRUCTIONS

1. Secure the Edelbrock bottle heater around the bottle using the Velcro straps. Mount the heater around the bottom section in a manner so that the end gap is at the top of the mounted bottle, making sure that the electrical connections are free. Do not cover the bottle label.
Important Note: Please ensure that the bottle heater is installed snugly with no ripples. The bottle heater must completely contact the bottle.
2. Place thermostat assembly under one of the velcro straps. Position it between the bottle surface and the strap, ensuring the thermostat is in full contact with the bottle. This is your bottle temperature reference signal and it must be installed correctly or damage may occur.
3. Mount the relay assembly in an area close to the bottle in a location that will be as moisture free as possible. Keep the relay assembly away from high traffic areas. Hard or blunt impacts can damage the relay.
4. Route the red wire from the bottle heater to the blue wire on the relay.
5. Connect the black wire from the heater to a chassis ground. Remember to leave enough wire for bottle removal and replacement before and after filling.
6. Connect one(1) wire from the thermostat to the black wire on the relay assembly.
7. Connect the other wire on the thermostat to a good chassis ground. Remember to leave enough wire for bottle heater movement during bottle removal and replacement before and after filling.
8. Route the red wire on the relay harness, (that includes the inline fuse) directly to the positive side battery post or starter solenoid post that the battery cable attaches to. This is done to ensure that the maximum current draw is done through the relay and not the switch. Failure to attach this wire directly to either of these two locations can result in possible electrical failure. Use appropriate connector to splice into power wire (minimum 12-gauge wire).

9. Mount the bottle heater on-off toggle switch in the passenger compartment. Place it in a convenient and visible location. Ensure that during the installation, the lighted portion of the switch is working and easily visible.
10. Connect terminal #1 from the toggle switch to an "ignition-switched" +12 volt source. We recommend that you connect this wire to the switched-on power of the vehicle's nitrous system arming switch. This ensures that the heater can only be activated when the nitrous system is armed.
11. Connect terminal #2 from the toggle switch to the white wire on the relay.
12. Connect terminal #3 to a good chassis ground.

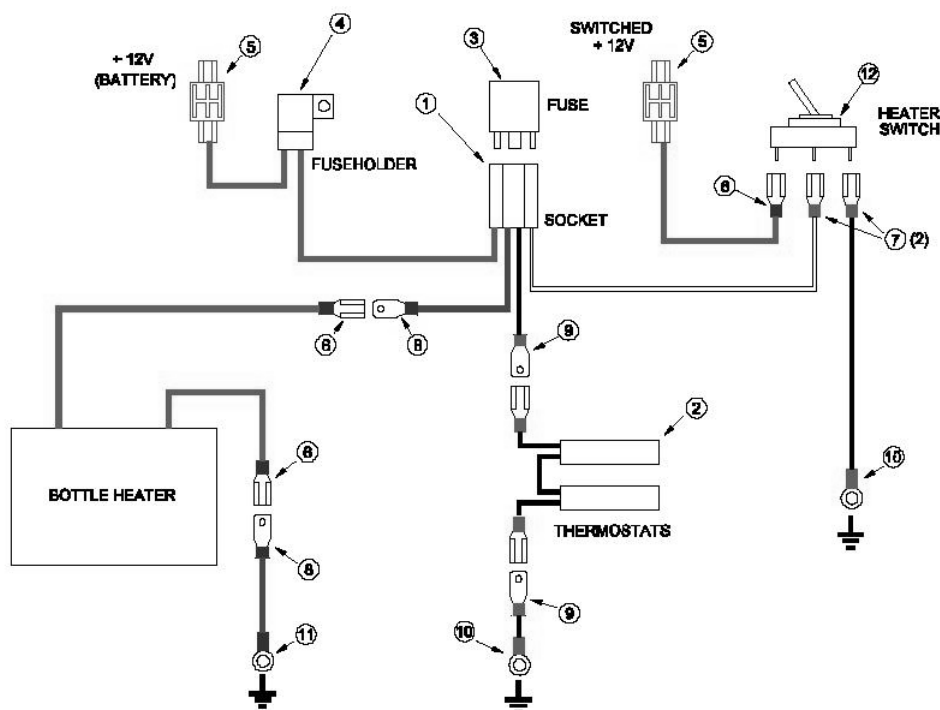

Wiring Diagram

Item #	Qty.	Description
1	1	Nitrous Relay Receptacle
2	1	Thermostat Assembly
3	1	Relay, SPDT, with Diode
4	1	Fuse, ATO, 25 Amp
5	2	Crimp-on Splice Connector
6	3	Crimp-on Disconnect Terminal, Female, Blue
7	2	Crimp-on Disconnect Terminal, Female, Red
8	2	Crimp-on Disconnect Terminal, Male, Blue
9	2	Crimp-on Disconnect Terminal, Male, Blue
10	2	Crimp-on Ring Terminal, Red
11	1	Crimp-on Ring Terminal, Blue
12	1	Switch, Toggle, Power, Lighted

IMPORTANT WARNING

This Edelbrock heater should never be used without the thermostats installed. The thermostats must always be in contact with the surface of the bottle in order for the thermostats to properly sense the bottle temperature. The thermostats have a cut-in and cut-out setting at 85° F

+/- 5° F. Failure to follow this important warning will result in the temperature of the bottle to rise to unsafe temperatures and the pressure within the bottle to rise to levels that could lead the bottle Pressure Relief Device to rupture, causing the bottle contents to empty.

To Test Bottle Heater for Correct Operation:

1. Turn ignition key to the “run” position.
2. Turn the vehicle’s nitrous system toggle switch to the “on” position.
3. Turn the bottle heater toggle switch to the “on” position.
4. A “click” should be heard from the heater’s relay when first activated as long as the thermostats are below 85° F.
5. Heater should now start to warm up. It may take a few seconds for the heater to heat up to correct operating temperature.
6. When bottle temperature reaches near 85-90° F, the thermostats will cut off the ground to the relay, deactivating the heater. When temperature drops below 85° F, the relay will be grounded through the thermostats, re-activating the heater.

Troubleshooting

- **Heater Takes a Long Time to Heat Up.**

1. Be sure thermostat touches bottle and is positioned between end gap of heater. Heater will not operate correctly if thermostat comes in contact or is too close to the heater element itself.
2. Inspect all ground connections. Check for shorts.

- **Bottle Heater Does Not Get Hot.**

1. Ensure that there is power through the relay. Temporarily place black wire from relay to ground. This will bypass the thermostat and will activate the relay to supply power to the heater. If this does not activate the heater, check below items. Ensure all electrical connections are made as shown in diagram.
2. Check for bad inline fuse. Replace with a 25 amp. fuse.
3. Check toggle switch.
4. Check all wires for shorts.
5. Check all ground connections.
6. Check thermostat. When temperatures are below 85° F, there will be continuity on the thermostat wires. When there is no continuity below 85° F, replace thermostat.

CAUTION:

1. The bottle heater surface can achieve temperatures in excess of 400 degrees. Do not attempt to handle, adjust, or remove from the bottle while the heater is in operation.
2. Do not touch heater surface while in operation. Severe burns to the skin can result.
3. Do not rest or lie heating element against flammable or temperature sensitive materials, objects, paints, or coatings as they could be caused to ignite due to the excessively high temperatures.
4. Do not operate this heater unless installed properly and securely attached to a nitrous cylinder as damage to the heater could result.
5. Do not operate this heater when attached to a nitrous cylinder that has a closed cylinder valve as this could cause high in-cylinder pressures and cause the pressure relief device to open and release the bottle's contents.
6. Do not operate this heater for extended periods of time.
7. Do not expose heater to an open flame as this can cause the heating element to fail.
8. Do not rest the heating element against a vehicle's structural member or any hard surface while attached to the bottle as this could damage the internal element windings within the heater.
9. Do not attempt to remove the bottle from the bottle mounting in the vehicle without first removing the bottle heater. Contact with the bottle mounting brackets could cause damage to the internal wiring within the heater.

Always refer to your Nitrous System Owner's Manual or Instructions for safety precautions when performing any service on your Nitrous System.

Edelbrock Corporation shall not be liable for any and all consequential damages occasioned by the breach of any written or implied warranty pertaining to this sale in excess of the purchase price of the product sold.



Edelbrock Corporation, 2700 California St., Torrance, CA 90503

Tech Line: 1-800-416-8628

E-Mail: Edelbrock@Edelbrock.com