



VICTOR RAM 23° INTAKE MANIFOLD
For Small-Block Chevrolet V8 Heads
Catalog #7070 (Base Only) #7073 (Top Only)
INSTALLATION INSTRUCTIONS

PLEASE study these instructions carefully before beginning this installation. Most installations can be accomplished with common tools and procedures. However, you should be familiar with and comfortable working on your vehicle. If you do not feel comfortable performing this installation, it is recommended to have the installation completed by a qualified mechanic. If you have any questions, please call our **Technical Hotline at: 1-800-416-8628**, 7:00 am - 5:00 pm, Pacific Standard Time, Monday through Friday.

IMPORTANT NOTE: Proper installation is the responsibility of the installer.

Improper installation will void your warranty and may result in poor performance and engine or vehicle damage.

DESCRIPTION: This intake manifold is for racing applications ONLY. The Victor Ram 23° intake manifold is a tunnel-ram style intake manifold, designed for racing applications operating in the 6,500-10,000 RPM range. It may be used with any combination designed to operate within that range. #7070 is a manifold base only and must be paired with the removable top #7073 (sold separately). The #7073 top is compatible with dual, sideways mounted, standard-flange carburetors.

ACCESSORIES & INSTALLATION ITEMS: Major recommendations are listed below. See our catalog for details. **To order a catalog, call (800) FUN-TEAM**, or visit www.edelbrock.com.

CARBURETOR RECOMMENDATIONS: Using Top #7073

CARBURETOR (QTY. 2)	PARTS REQUIRED FOR INSTALLATION
Appropriate Standard-Flange Racing Carburetor	#7071 Throttle Linkage Kit - Sideways Mounted

GASKETS: Use appropriate intake manifold gaskets. Replacement manifold top-to-base gaskets are available as needed: Edelbrock #6988.

CAMSHAFT AND HEADERS: The Victor Tunnel Ram manifold is compatible with racing camshafts and headers.

PREP AND TUNING FOR POWER:

PORT MATCHING: Each intake runner should be matched to the cylinder head port size on all four sides of runner exit. This would be the floor, roof and each sidewall per the included illustration (**See Fig. 1**). Any sharp edges left from port runner enlargement should be radius-blended to prevent high rpm air/fuel separation at the cylinder head. Due to the as-cast size of the Victor Ram 23° manifold runners, very small amounts of material need to be removed to match ports. No other modifications or material removal is necessary. Refer to illustration for floor radius. Hard-roll polishing is acceptable, but removal of substantial amounts of manifold material can impair its performance by upsetting air/fuel distribution among cylinders.

1. Carburetor jetting will vary according to engine build and atmospheric conditions.
2. Aftermarket ignition systems may be used with this intake manifold and are recommended.
3. Use modified or high performance cylinder heads such as Edelbrock Victor Series cylinder heads.
4. Header primary tube diameter should be determined by the engine builder, depending on the specific engine combination.

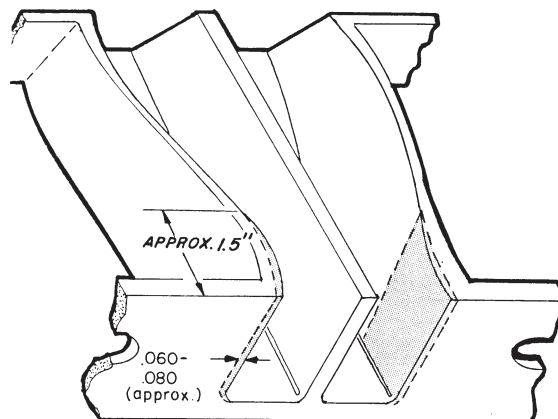

Figure 1 - Intake Manifold to Cylinder Head Port Match

INSTALLATION INSTRUCTIONS

INTAKE MANIFOLD BASE

1. Use only recommended intake gaskets set when installing this intake manifold.
2. Fully clean the cylinder head intake flanges and the engine block end seal surfaces.
3. Apply Edelbrock Gasgacinch sealant, P/N 9300, to both cylinder head flanges and to the cylinder head side of the gaskets, allow to air dry, and attach the intake gaskets.
4. Do not use cork or rubber end seals. Use RTV silicone sealer instead. Apply a ¼" high bead across each block end seal surface, overlapping the intake gasket at the four corners. This method will eliminate end seal slippage.
5. Install the intake manifold hold-down bolts. Hand tighten all bolts to approximately 5 ft./lbs. to center the manifold on the engine.
6. Torque all of the remaining manifold bolts in two steps by the sequence shown in **Figure 2** to 25 ft./lbs.

INTAKE MANIFOLD TOP

1. Apply Edelbrock Gasgacinch sealant, P/N 9300, to the gasket mating surface and install the gasket and manifold top.
2. Install and tighten the supplied hold down bolts to 15-18 ft./lbs, starting with the inner bolts and working outwards in a circular sequence.

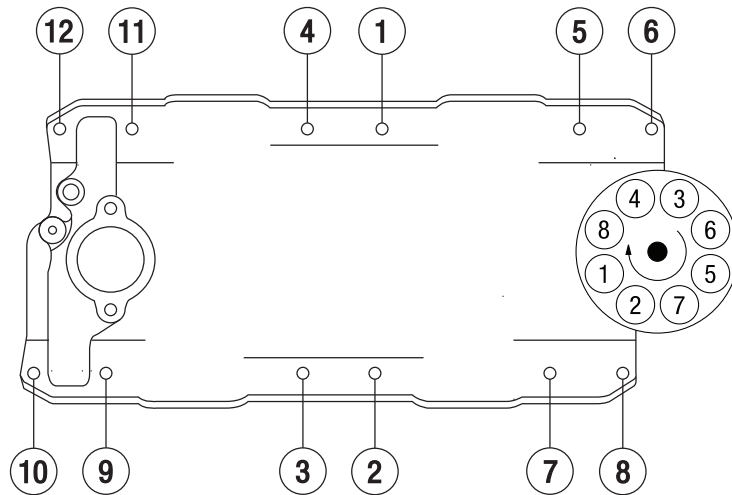

Figure 2 - Small-Block Chevrolet Bolt Torque Sequence
Torque Bolts To 25 ft./lbs.
Firing Order: 1-8-4-3-6-5-7-2
Turn Distributor Counter-Clockwise to Advance ignition Timing



Edelbrock LLC • 2700 California St. • Torrance, CA 90503
Tech Line: 800-416-8628