



**E-TEC 170 AND E-TEC 200 ALUMINUM CYLINDER HEADS
For Small Block Chevrolet Using Vortec Style Manifolds
Catalog #60959, #60969 (Bare)
Catalog #60979, #60989 (Complete)**

INSTALLATION INSTRUCTIONS

PLEASE study these instructions carefully before beginning this installation. Most installations can be accomplished with common tools and procedures. However, you should be familiar with and comfortable working on your vehicle. If you do not feel comfortable performing this installation, it is recommended to have the installation completed by a qualified mechanic. If you have any questions, please call our **Technical Hotline at: 1-800-416-8628**, 7:00 am - 5:00 pm, Pacific Standard Time, Monday through Friday or e-mail us at Edelbrock@Edelbrock.com.

IMPORTANT NOTE: Proper installation is the responsibility of the installer. Improper installation will void your warranty and may result in poor performance and engine or vehicle damage.

DESCRIPTION: Edelbrock E-Tec 170 cylinder heads are designed for street/high performance use on 302, 327, 350, and 400 c.i.d. Small block Chevrolet engines using Vortec style manifolds. E-Tec 200 cylinder heads are high-end street and racing cylinder heads intended for large displacement small block Chevrolet engines. Both of these heads feature 64cc combustion chambers. Complete cylinder heads come assembled with valvetrain parts capable of operating up to 6500 rpm. **Higher rpm applications will require the use of suitable valvetrain parts, such as larger valve springs and retainers.** Other outstanding features include phosphor-bronze valve guides, ductile iron valve seats and premium one-piece, stainless steel, high-flow valves, heat-treated machined steel retainers and valve locks, rocker studs, 5/16" guide plates, and heavy duty valve springs which work with cams having valve lifts up to .600". Spring load at .600" lift is 340 lbs. Check camshaft manufacturer's spring load specifications when using other than Edelbrock camshafts. These powerful heads use the **stock Vortec location for intake and exhaust flanges and bolt holes**, and centerbolt valve cover rails for compatibility with original equipment and aftermarket parts. Bolt holes for exhaust and intake flanges and rocker studs are fitted with helicoil inserts for increased strength.

APPLICATIONS:

- 60959 (bare) / 60979 (complete) -** 302, 327, 350, and 400 c.i.d. Small block Chevrolet engines using Vortec style manifolds. They also replace original equipment on 1996 through 1998 Vortec 5.7L equipped vehicles (C.A.R.B. E.O. pending. Call Edelbrock for detailed information). E-Tec 170 feature high velocity 170cc intake ports and 70cc exhaust ports. Complete heads feature installed 1.940" intake and 1.550" exhaust valves.
- 60696 (bare) / 60989 (complete) -** Intended for large displacement small block Chevrolet engines. E-Tec 200 cylinder heads feature 200cc intake and 78cc exhaust ports. Complete cylinder heads include 2.020" intake and 1.600" exhaust valves.

Complete cylinder heads are assembled with the following components:

- Stainless steel, one-piece, swirl-polished intake and exhaust valves with under-cut stems for increased flow
- 2-ring positive oil control seals on 6097; High quality viton lip seals with metal jacket on 6098
- Edelbrock Sure-Seat valve springs #5767
- Retainers #9724
- Valve keepers #9616 for PN 6098, #9611 for PN 6097
- Valve spring seats #5769
- 5/16" pushrod guide plates, or hardened washers* for use with self-aligning rocker arms.

**When using self-aligning rocker arms, remove guide plates and install the supplied hardened washers underneath the rocker studs.*

NOTE: Complete cylinder heads are assembled and prepared for installation right out of the box. **Bare cylinder heads will have valve guides and seats installed, but will require final guide sizing and a valve job to match the valves you will be using.**

BEFORE BEGINNING INSTALLATION

IMPORTANT NOTES: READ BEFORE BEGINNING INSTALLATION!

For a successful installation, Edelbrock E-Tec 170/200 Cylinder Heads require some components other than original equipment parts. To complete your installation, you will need the following items:

- ❑ Head gaskets; Edelbrock # 7310, Fel-Pro #7733 PT-2 or #17030 Marine Gasket, GM #10105117, or Detroit Gasket #5565HG (see installation instructions)
- ❑ Intake manifold gaskets; Edelbrock #7235, GM #12529094; or Fel-Pro #1255 or equivalent
- ❑ Exhaust gaskets; Edelbrock #7204, Fel-Pro #1404 for PN 6097, #1405 for PN 6098, or equivalent

NOTE: Edelbrock Cylinder Head Gasket Set #7367 may also be used in place of individual gaskets. This set contains all gaskets necessary for cylinder head installation, including cylinder head, intake, exhaust, and valve cover gaskets.

- ❑ Edelbrock head bolt kit #8550 (see instructions below)
- ❑ 14mm x 3/4" reach x 5/8" hex, gasketed spark plugs (heat range to be determined by specific application)
- ❑ Non-self aligning, roller tip rocker arms such as Crane #11801-16, Sealed Power #R-865R, Pioneer-Barnes #818001, or equivalent, or self-aligning rocker arms such as GM #12495490 (stamped steel, 1.5:1 ratio), GM #12370838 (aluminum roller, 1.5:1 ratio), & GM #12370839 (aluminum roller 1.6:1 ratio) or equivalent

- ❑ Hardened Pushrods; .100" longer-than-stock (if using stock type rocker arms); Cam Dynamics #1002; Competition Cams #7693-16; Crane #11622-16; Crower #70311-2; Isky #203 HG + .100; Pioneer-Barnes #815215, or equivalent (for conventional hydraulic lifter cams), Competition Cams #7949-16; Isky #203-HG Minus .460; Lunati #83132; or equivalent (for hydraulic roller lifter cams)

CHECKING CLEARANCES: Prior to installation, it is highly recommended that valve-to-piston clearances are checked and corrected to minimum specs, if necessary. A minimum of 0.100" clearance is recommended for both intake and exhaust. These cylinder heads have different than stock valve sizes and may not work with the valve pockets in stock pistons, especially if a high lift cam is used. The use of aftermarket pistons and/or custom machining to your pistons may be required. Actual valve-to-piston clearance should be specified by your camshaft manufacturer. If these cylinder heads are used on small bore engines, valve-to-bore clearance should also be checked, and the top of the bore notched for clearance, if necessary.

ROCKER GEOMETRY: Rocker geometry should be checked, making sure that the contact point of the roller (or pad on a stock rocker arm) remains properly on the valve tip and does not roll off the edge. Visual inspection of the rockers, valve springs, retainers, and pushrods should be made to ensure that none of these components come into improper contact with each other. If problems with valve train geometry occur, changes such as pushrod length may have to be made.

ACCESSORIES

Although Edelbrock E-Tec cylinder heads will accept OEM components (rocker arms, valve covers, intake manifold, head bolts, etc.), we highly recommend that premium quality hardware be used with your new heads.

- **Head Bolts or Studs:** High quality head studs or head bolts with hardened washers must be used to prevent galling of the aluminum bolt bosses. Edelbrock head bolt kit #8550 includes all bolts which must be used with these cylinder heads. Stock head bolts may be used if they meet these specs for length: 1-3/4" (short bolts); 3" (medium bolts); 3- 13/16" (long bolts). Bolts not meeting these specs do not have enough thread engagement for use with hardened washers. The recommended hardened washers are GM #10051155, ARP #200-8511, or equivalent. Bolt threads, underside of bolt heads, and washers should be lubricated with an oil/moly mix prior to installation and torquing. Use thread sealant on any bolts that go into coolant passages.
- **Rocker Arms and Valve Train:** Stock (stamped type) rockers will require +.100" longer-than-stock hardened pushrods to maintain proper geometry. The valve springs supplied will accommodate valve lifts up to .600", which is much higher than stock rocker arms will allow. Long slot stamped or roller rocker arms will be required if your camshaft has more than .480" lift.

CAUTION: Some Chevrolet V8 cylinder heads, including Vortec heads, are factory-equipped with "self-aligning" rocker arms.

These rocker arms have a stamped recess on the valve tip end to guide the rocker arm on the valve stem which allows the rocker arm to guide the pushrod. Edelbrock E-Tec cylinder heads are equipped with both hardened pushrod guideplates and hardened washers to be used with "self-aligning" rocker arms. In any case, always check rocker-to-valve tip alignment and adjust as needed.

- **Valve Covers:** E-Tec heads will accept standard perimeter bolt and centerbolt valve covers. The Perimeter bolt pattern is not in stock location. Check accessory bracket fit before using perimeter bolt style valve covers with these heads. Edelbrock perimeter pattern #4449, 4248, or 4244 or centerbolt pattern #4246 and 4247 will work with E-Tec heads.

NOTE: Most taller than stock valve covers will interfere with the EGR valve and are not legal on emission-controlled vehicles. Perimeter bolt pattern valve covers MUST use the four (4) supplied rubber washers between the valve cover and any metal washers being used, as well as a bit of RTV silicone sealer between the valve cover bolt heads, and their corresponding metal washers, in order to prevent oil leaks.

- Intake Manifold:** Although stock Vortec intake manifold will fit, Edelbrock E-Tec 170 Cylinder Heads are matched in size and operating range with Edelbrock Performer, Performer RPM, and Performer RPM Air-Gap Intake Manifolds. Part numbers 2116, 7116 and 7516. 7116, 7516, 2912 and 2913 are recommended for E-Tec 200. Do not use cork or rubber end seals supplied with gaskets. Set the manifold on the engine with gaskets installed and measure the gap between the block and the manifold end seal surface. Remove the manifold and apply enough automotive O2 sensor-safe RTV silicone sealer to fill the gap along front and rear of block, overlapping gaskets at the four corners. Follow gasket manufacturer's recommendation for the use or non-use of sealant for the type of intake gasket used. Install manifold and apply Loctite 242 thread locker or equivalent to the intake manifold bolt threads and torque down to 11 ft./lbs. using the factory specs for torque sequence.
- Exhaust Headers:** Any header or manifold designed for original equipment Vortec heads will fit Edelbrock E-Tec 170 Cylinder Heads. E-Tec 200 will require the use of headers suitable for Fel-Pro #1405 (1-3/4" is minimum recommended). Exhaust ports are CNC-profiled to match Fel-Pro #1404 exhaust gaskets for 6097 or 1405 for 6098, which are recommended for these applications.
- Spark Plugs:** Use 14mm x 3/4" reach gasketed spark plugs. Heat range may vary by application, but we recommend Champion RC-12YC (or equivalent) for most street-driven applications. **Use anti-seize on the plug threads to prevent galling in the cylinder head, and torque to 10 ft./lbs. Do not overtighten sparkplugs!**

INSTALLATION PROCEDURE

Installation is the same as for original equipment cylinder heads. Consult service manual for specific procedures, if necessary. For 350 c.i.d. and smaller engines (4.00" bore or less), we recommend Fel-Pro #7733-PT2 head gasket for applications up to 420 HP, #17030 marine gasket for up to 450 HP and Fel-Pro #1003 beyond that level. Also, GM #10105117 or Detroit gasket #5565HG. For 400 c.i.d. or larger, Fel-Pro #8364-PT for moderate horsepower applications, and #1014 for high power applications. Also, GM #10159455 or Detroit gasket #55431HG. In any case, **for 400 c.i.d. applications, steam holes must be drilled in**

cylinder heads as shown in Fig. 2. Be sure that the surface of the block and the surface of the head are thoroughly cleaned to remove any oily film before installation. Use alcohol or lacquer thinner on a lint-free rag to clean. Apply Teflon pipe sealant or suitable sealer to head bolt threads. Apply 30W oil or suitable lubricant under side of bolt heads and washers. Torque to 65 ft./lbs. in three steps (40, 55, 65) following the factory tightening sequence (see Figure 1). A re-torque is recommended after initial start-up and cool-down (allow 2-3 hours for adequate cooling).

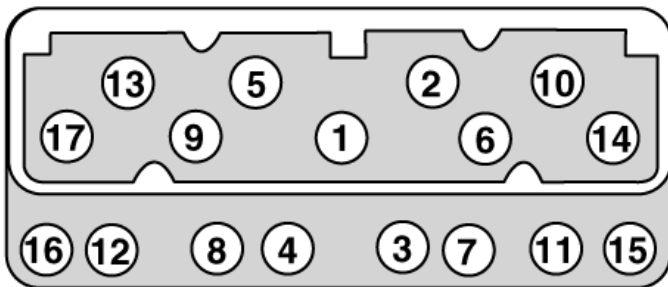

Figure 1 - SBC Cylinder Head Bolt Torque Sequence
Torque Bolts to 65 ft./lbs.
(Torque in 3 steps, gradually approaching final torque spec.)

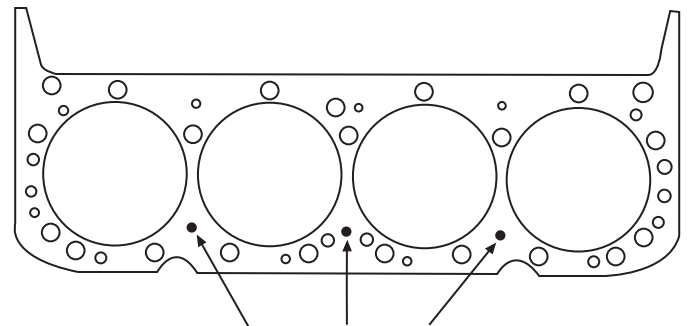

Figure 2 - Steam Hole Location for 400 c.i.d. engines only
 Drill three 0.125" holes in each head using 400 c.i.d. head gasket as a guide. Drill only the three lower steam holes (closest to the spark plugs) as indicated in Fig. 2. Drill straight into the head (90° to the deck) until drilling breaks through into water jacket (about 5/8").

COOLANT STEAM HOLES ABSOLUTELY MUST NOT OVERLAP INTO THE HEAD GASKET SEALING RING (FIRE RING) AREA.

SPECIAL INSTRUCTIONS FOR E-TEC ALUMINUM CYLINDER HEADS #60979 & #60989

Complete E-Tec cylinder heads #60979 and #60989 are sold with the pushrod guide plates and rocker studs installed, but they will require checking for proper valve train and **pushrod clearance** before operating engine.

PUSHROD GUIDE PLATE ALIGNMENT: The pushrod guide plates are attached to the cylinder heads with two (each) rocker studs. There is enough clearance around the stud holes to adjust the guide plates for optimum alignment of your valve train components.

- After the heads have been bolted on your engine and torqued to specs, install your pushrods, rocker arms, and rocker arm adjusting nuts.

2. Check pushrod-to-cylinder head clearance. **YOU MUST CHECK TO ENSURE THAT THERE IS CLEARANCE BETWEEN THE PUSHRODS AND THE CYLINDER HEADS (.005" minimum).**
3. If adequate clearance exists between the pushrod and head, slowly turn engine through at least two revolutions while watching pushrod. Make sure that pushrod does not rub on the head either at full lift or when the valve is seated.
4. If pushrod rubs on the cylinder head, remove rocker arms, loosen the rocker studs and move the guide plate as needed to provide clearance.
5. After checking all pushrods for proper clearance, ensure that the tip of the rocker arm is making adequate contact with the top of the valve stem.
6. Carefully re-torque to 45 ft./lbs. any rocker studs that were loosened. Check alignment again to be sure that the guide plates did not move while torquing the studs.

SPECIFICATIONS

Head Bolt Torque:	65 ft-lbs (in steps of 40, 55, 65)
Intake Bolt Torque:	11 ft./lbs.
Rocker Stud Torque:	45 ft./lbs. (See Instructions)
Deck Thickness:	5/8"
Combustion Chamber Volume:	64cc
Deck Surface Milling	Every .005"-.006" Removed is Approximately 1cc Decrease in Chamber Volume (Maximum Deck Milling = 060")
Intake Port Volume:	170cc (E-Tec 170)/200cc (E-Tec 200)
Exhaust Port Volume:	70cc (E-Tec 170)/78cc (E-Tec 200)
Valve Seats:	Hardened, Interlocking Ductile Iron. Compatible with Unleaded Fuels
Valve Size:	PN 60979 - Intake 1.940", Exhaust 1.550" PN 60989 - Intake 2.020", Exhaust 1.600"
Valve Locks:	3/8" x 7° (#9612)
Valve Spring Retainers:	7° 4140 Steel (#9734)
Valve Spring Diameter:	1.450"
Valve Spring Installed Height:	1.800"
Valve Spring Seat Pressure:	120 lbs.
Valve Spring Pressure @ .600" Lift:	120 lbs.
Maximum Valve Lift:	.600"
Rocker Arms:	Adjustable, Non-Self Aligning, Roller Rocker Arms Recommended Self-Aligning Rocker Arms Must Remove Guide Plates and Install Washers Under Rocker Studs
Pushrods:	.100" Longer than Stock Required with Stock Type Stamped Steel Rocker Arms. Hardened Pushrods Required with Guide Plates
Spark Plugs:	14mm x 3/4" Reach, 5/8" Hex, Gasketed Seat



Edelbrock Corporation • 2700 California St. • Torrance, CA 90503
Tech-Line: 1-800-416-8628 • E-Mail: Edelbrock@Edelbrock.com