

PRO-FLO[®] 3
ELECTRONIC
FUEL INJECTION

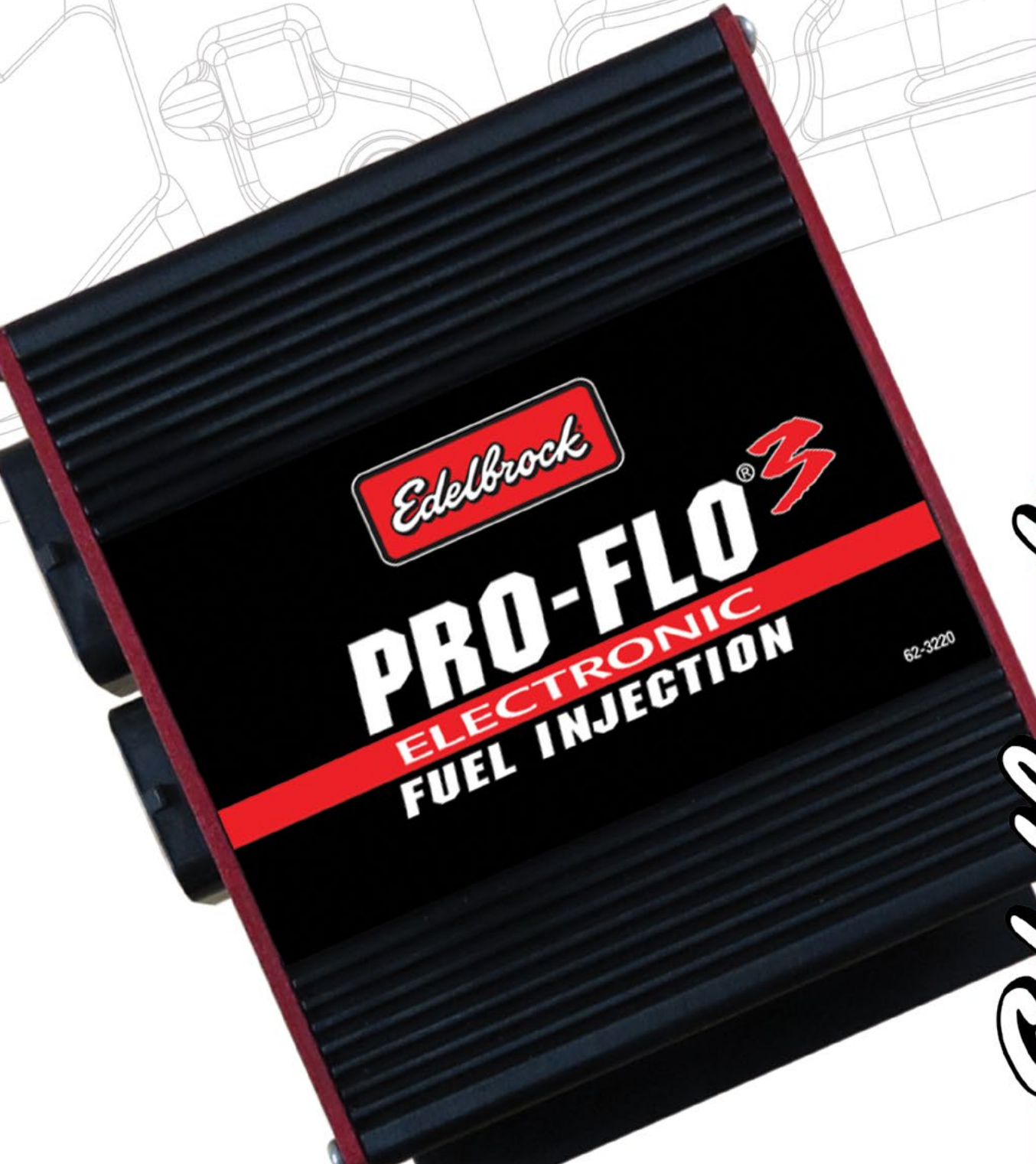
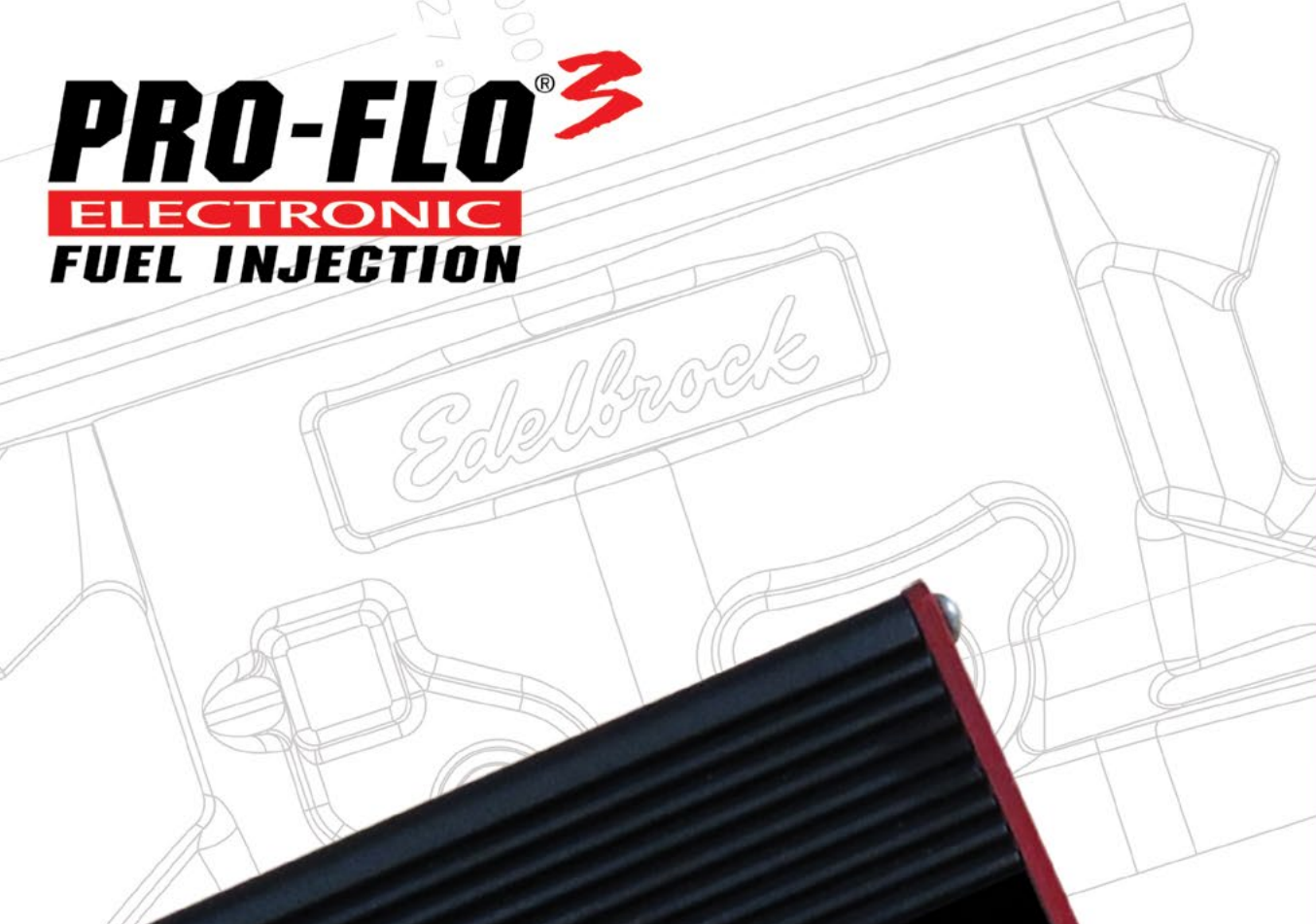

Installation Instructions

Edelbrock[®]

TABLE OF CONTENTS

Introduction.....	1-2
Tools and System Requirements	2
Fuel System Requirements.....	3
Primary Kit Components.....	4
Component Layout.....	5-8
Main Harness Layout	9
Wideband Oxygen Sensor Installation.....	10
Checking Hood Clearance	11
Pro-Flo 3 Installation	12-14
Fan and A/C Trigger Installation	15
Fan and A/C Trigger Diagram	16
Wiring w/ Pro-Flo Distributor & CDI Box.....	16
Main Harness Schematic.....	18
Injector Firing Order Configurations	19
Pro-Flo 3 EFI Setup Wizard Map Matrix	20-23
OEM Firing Order	23
Warranty.....	24

INTRODUCTION

Thank you for selecting the Edelbrock Pro-Flo 3 EFI system. This is an electronic fuel injection system intended for V8 engines originally equipped with carburetors. The Pro-Flo 3 EFI system can be paired via bluetooth connection with an exclusive tuning software, E-Tuner, which is available as a free app for most Android-based tablets and smartphones. The use of a laptop PC is not required for tuning. The E-Tuner Android app will enable real-time system performance monitoring and fine tuning adjustments. The Pro-Flo 3 EFI system offers you the most bang for your buck, along with out-of-the-box performance from a name you can trust...Edelbrock!

If you have any questions, do not hesitate to call our EFI Technical Support at: (800) 416-8628, 7am-5pm PST, Monday-Friday.

E-TUNER SOFTWARE UPDATES

Edelbrock periodically releases improved versions of the E-Tuner app software. These updates can include improvements to pre-installed calibration maps, additional calibration maps and updates to the user interface to improve the overall functionality of the software. **It is recommended to check the Google Play Store or the Edelbrock website to verify that you have the most recent version of the app.**

IMPORTANT WARNINGS

Before beginning the installation, verify that all components are present in the box. Inspect each component for damage that may have occurred in transit. If any parts are missing or damaged, contact Edelbrock Technical Support at (800) 416-8628, not your parts distributor.

CAREFULLY STUDY AND UNDERSTAND ALL INSTRUCTIONS BEFORE BEGINNING THIS INSTALLATION.

NOTE: *The installation can be accomplished using common tools and procedures. However, it is highly recommended to have a solid understanding of automotive repairs and modifications, and be familiar with and comfortable working on your vehicle and your vehicle's fuel system. If you do not feel comfortable working on your vehicle, it is recommended to have the installation completed by a professional mechanic.*

PROPER INSTALLATION IS THE RESPONSIBILITY OF THE INSTALLER. IMPROPER INSTALLATION WILL VOID ALL MANUFACTURER'S STANDARD WARRANTIES AND MAY RESULT IN POOR PERFORMANCE AND/OR DAMAGE TO THE ENGINE AND/OR VEHICLE.

WARNING: *The Edelbrock E-Tuner Software is intended to be used as a hands-free tuning tool and gauge display. Any function that requires prolonged attention should only be performed after coming to a complete stop. Distracted driving is extremely dangerous and illegal in most states. If adjustments are to be made during driving, always stop the vehicle in a safe location before performing any adjustments, or have a passenger perform the necessary adjustments. Please check with your local laws for legal mounting locations in your vehicle.*

O2 SENSOR INSTALLATION

It is suggested that the O2 sensor bung be installed by a professional muffler shop prior to the installation of the Edelbrock Pro-Flo 3 EFI system. **DO NOT** drive the vehicle with the O2 sensor unplugged, sensor damage **will** occur. An O2 sensor bung plug is provided for your convenience. Refer to Page #8 for the O2 sensor installation procedure.

EMISSION CONTROLS

The Edelbrock Pro-Flo 3 EFI system will not accept stock emissions control systems. Check your local emissions laws for requirements before installing the Pro-Flo 3 EFI system. ***This system is not legal for use on pollution-controlled motor vehicles.***

FUEL REQUIREMENTS

Because the Pro-Flo 3 EFI system uses a wideband oxygen (O2) sensor, unleaded fuel must be used at all times. **Using leaded fuels will damage the O2 sensor and void your warranty.** If leaded fuel is present in your fuel tank, the tank must be drained and filled with unleaded fuel. It is also recommended to have a full fuel tank before operating the vehicle (*after the installation*).

NOTE: *E85 fuels are not compatible with any Pro-Flo 3 EFI systems.*

AUTOMATIC TRANSMISSION CHECK

For best performance, economy, and emissions, the transmission kick down and shift points must be checked before and after the Pro-Flo 3 EFI installation.

SPARK PLUG WIRES

High EMI suppression spark plug wires are necessary, do not use solid core spark plug wires. Resistor type spark plugs are necessary.

EXHAUSTS SYSTEM

For best results, headers are recommended. For the Self Tuning function to properly operate, **the exhaust system must be completely sealed from header flange surface at cylinders heads to tailpipe.** The exhaust system should be completely inspected prior to installing the Pro-Flo 3 EFI system. All gaskets and hardware should be replaced. All hardware torques should be checked on regular bases.

CHARGING SYSTEM

The Pro-Flo 3 EFI System requires a constant battery voltage of 12.0 volts or greater to operate properly. Recommended battery capabilities are: 1000Ca @32°F / 800Ca @0°F. The vehicle's battery must be in good operating condition capable of maintaining a proper charge at all times. Verify the vehicle's charging system is operating properly and that the system voltage maintains 12.0 volts, or greater, at all times. All chassis grounds must be tight and clean. A ground cable from the engine block to chassis should be employed. All battery cables must be in good condition providing a clean tight connection to the battery.

BATTERY CHARGER PRECAUTIONS - PLEASE ADHERE TO THE FOLLOWING GUIDELINES OR DAMAGE TO ECU MAY OCCUR.

- Be sure the battery has a full charge prior to attempting to start the vehicle.
- Never use the "engine start or jump start" setting on a charger to start the engine.
- Do not set the battery charger above 10 amps when charging.
- Never turn on the ECU or attempt to start the engine with the battery charger is connected .
- Make sure the charger is not charging over 18.0 volts.
- If battery the battery is completely discharged, it is best to disconnect the negative terminal on the battery when charging.

COOLING SYSTEM

The minimum temperature requirement for the thermostat is 180°F.

TOOLS AND SYSTEM REQUIREMENTS

Use the following checklist for items needed.

- | | |
|--|--|
| <input type="checkbox"/> Wrench / Socket Set | <input type="checkbox"/> High-Heat Anti-Seize Compound |
| <input type="checkbox"/> 7/8" Oxygen Sensor Socket or Equivalent | <input type="checkbox"/> 180°F Thermostat |
| <input type="checkbox"/> Pliers (channel locks and hose clamp) | <input type="checkbox"/> Resistor Type Spark Plugs (<i>Use correct heat range for your particular application</i>) |
| <input type="checkbox"/> Screwdrivers (Phillips and Flathead) | <input type="checkbox"/> High EMI Suppression Spark Plug Wires (<i>DO NOT use solid core spark plug wires</i>) |
| <input type="checkbox"/> Gasket Scraper or Equivalent | <input type="checkbox"/> EFI Fuel System (<i>See fuel system recommendation</i>) |
| <input type="checkbox"/> Timing light | <input type="checkbox"/> Mechanical Fuel Pump Block Off Plate (<i>Except for vehicles running a Fuel Sump System #3605, 3606, 3607 & 36052</i>) |
| <input type="checkbox"/> Shop Rags | <input type="checkbox"/> Fuel fittings (<i>Additional fittings may be required depending on routing preferences. Visit www.russell.com</i>) |
| <input type="checkbox"/> Edelbrock Gasgacinch #9300 | <input type="checkbox"/> 30 AMP Automotive Relay (<i>If using electric fans or A/C Kick up - One relay required for each accessory</i>) |
| <input type="checkbox"/> Loctite 598 OEM High Temperature Silicone Gasket (02 Sensor Compatible) | |
| <input type="checkbox"/> Vehicle Wiring Diagram (if available) | |
| <input type="checkbox"/> Thread Sealer | |

FUEL SYSTEM REQUIREMENTS

The Pro-Flo 3 EFI system requires a high pressure fuel system providing 43-45 or 58-60 psi of fuel pressure with a flow rating of 57 GPH (215 liter/hr). If you purchased a kit without a fuel system, the following recommended options are available separately.

NOTE: Refer to pages 20 – 22, PRO FLO 3 EFI SETUP WIZARD MAP MATRIX, for available Engine Calibration I.D and system configurations.

Part Number 3604: Return-Style Fuel System: Can use any fuel pump with a minimum flow rating of 57 GPH (215 liter/hr). Fuel pressure must be regulated to 43-45 or 58-60 psi.

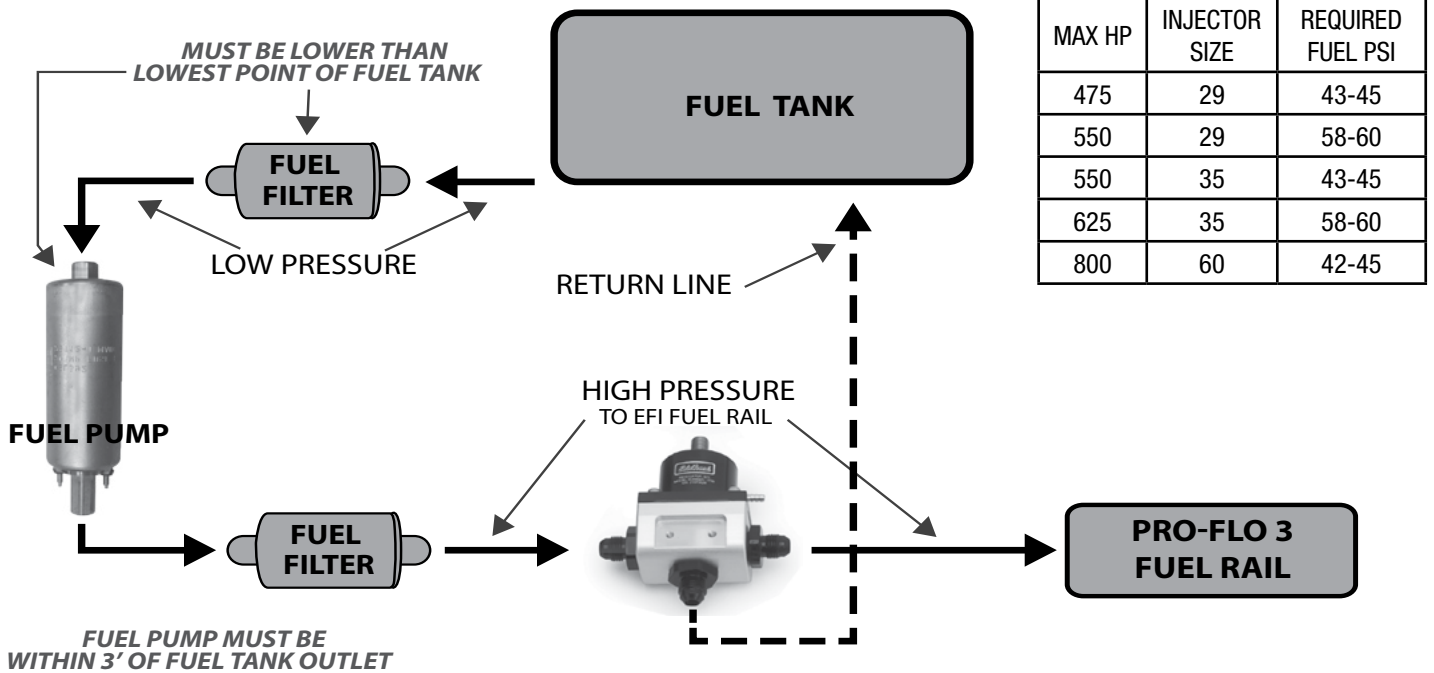

Part Number 3605: Universal EFI Fuel Sump System: Is provided with an internal 67 GPH (255 Liter HR) high pressure fuel pump and regulator. Fuel pressure is regulated to 58-60 psi.

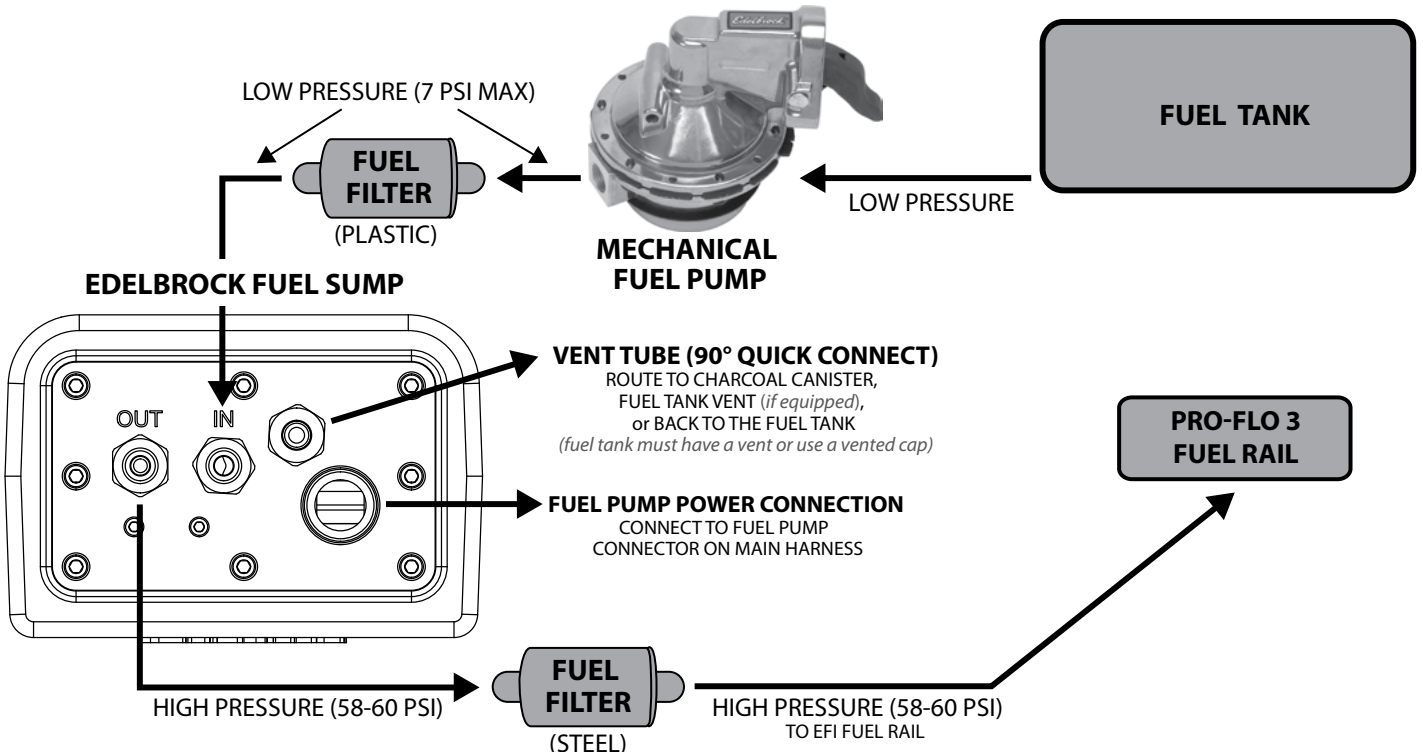

PRIMARY KIT COMPONENTS

(Images are for reference only and may not represent actual components.)

Item	P/N	QTY.	Description
1	Various	1	Pro-Flo 3 Manifold Assembly (4150 Style manifold shown)
2	37-3605	1	7" Tablet (if applicable)
3	37-3604	1	Oxygen Sensor
4	22-3220	1	Pro-Flo 3 R1e ECU
5	Various	1	Pro-Flo 3 Distributor
6	37-0110	1	Bluetooth Antenna
7	8041	1	Throttle & Trans Kick Down
8	37-1549	1	Car Charger w/ USB Cable
9	Various	2	Intake Manifold Gasket

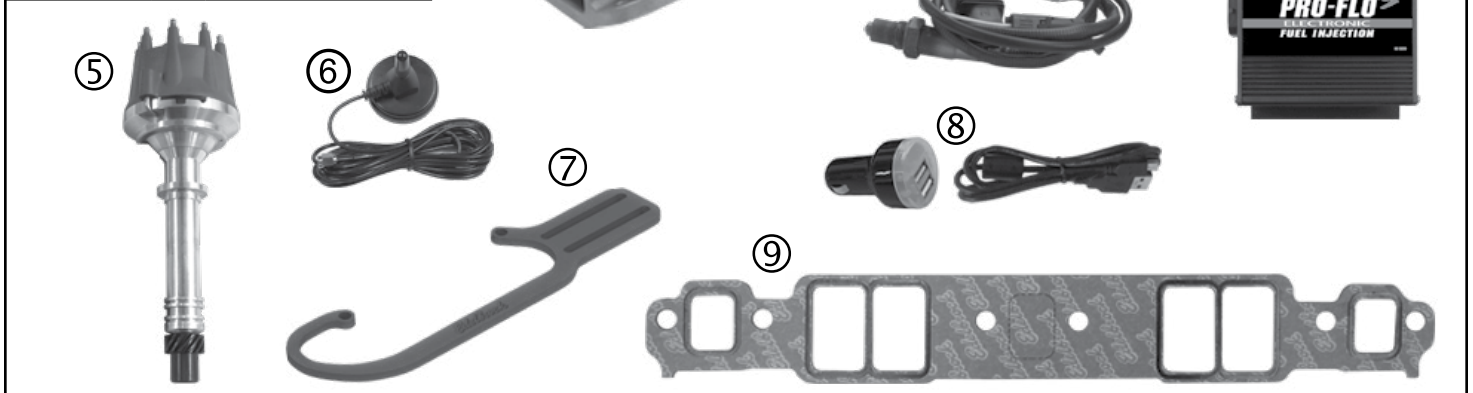

MAIN HARDWARE

(Images are for reference only and may not represent actual components.)

Item	P/N	QTY.	Description
1	36-3505	4	Sheet Metal Screw
2	38-0590	1	Throttle Return Spring Bracket
3	40-3970	1	1/2" to 3/8" Pipe Reducer
4	52-8097	1	Oxygen Sensor Bung Plug
5	52-9710	1	Oxygen Sensor Bung
6	72-1519	8	Neoprene Rubber Washer
7	74-4920	1	Throttle Return Spring
8	37-3499	1	Harness, Ignition Coil
9	37-91156	3	10" Pigtail w/ Contact Crimp
10	37-3518	1	Sensor, MAT
11	37-1620	1	Main Engine Harness
12	78-2004	10	11" Tie Wraps
13	37-3496	1	Distributor Extension Harness (Ford and some Chrysler Only) Not Pictured



PRO-FLO 3 4150 STYLE MANIFOLD - COMPONENT LAYOUT

The Edelbrock Pro-Flo 3 EFI system delivers fuel and air to the engine via an induction system consisting primarily of a 4-barrel throttle body, dual fuel rails, and eight fuel injectors. The induction system is fully assembled, tested, pressure checked, and flowed at the Edelbrock Factory in Torrance, California. Avoid disassembling these components if possible.

NOTE: ALL UNUSED VACUUM PORTS MUST BE CAPPED TO AVOID VACUUM LEAKS

4-BARREL THROTTLE BODY

The Pro-Flo 3 system uses a 4150 style flanged throttle body with four throttle blades arranged in a conventional 4-barrel pattern. The air valve can flow up to 1000 CFM.

**P/N 3220 SHOWN*

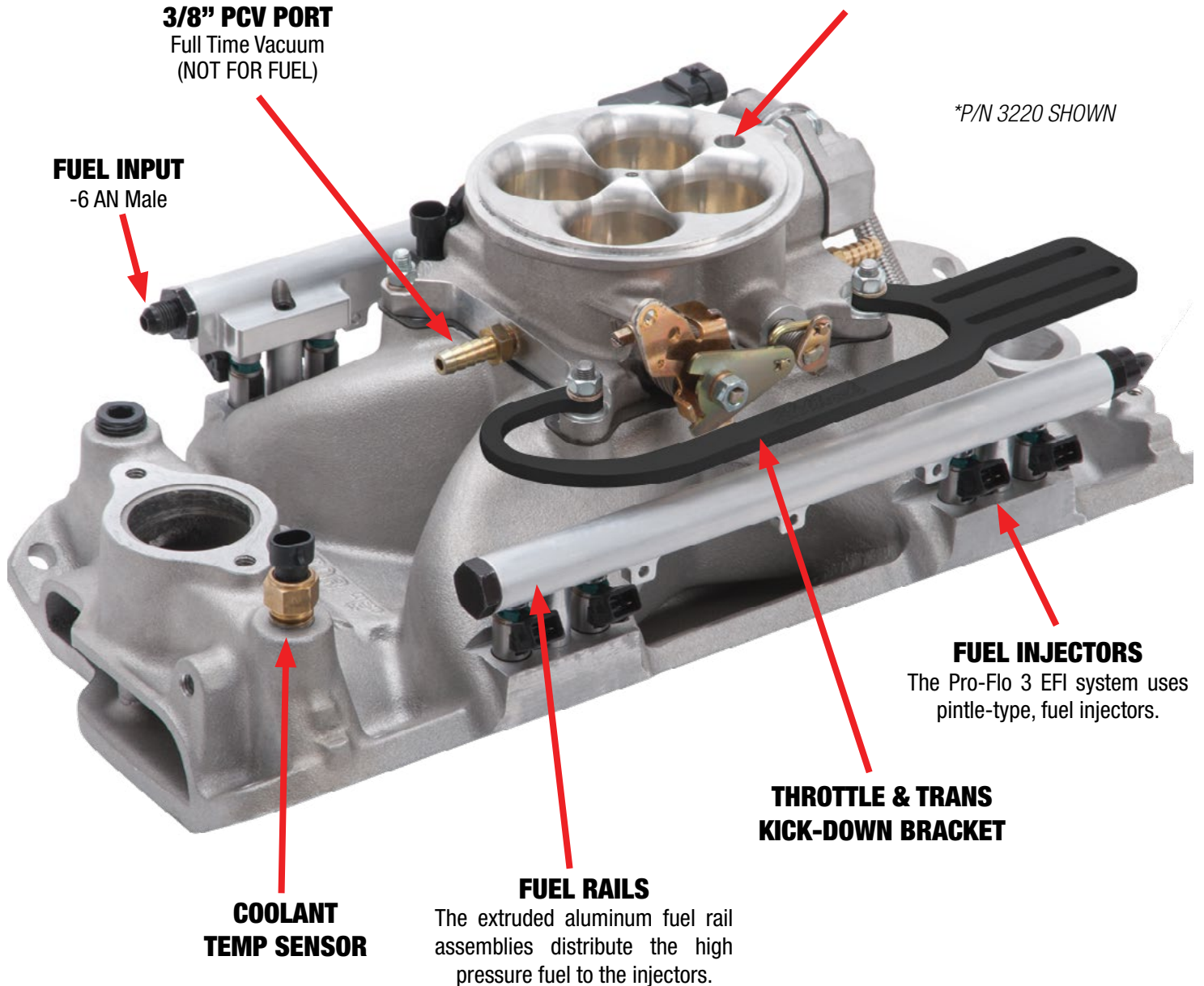

PRO FLO 3 4150 STYLE MANIFOLD - COMPONENT LAYOUT

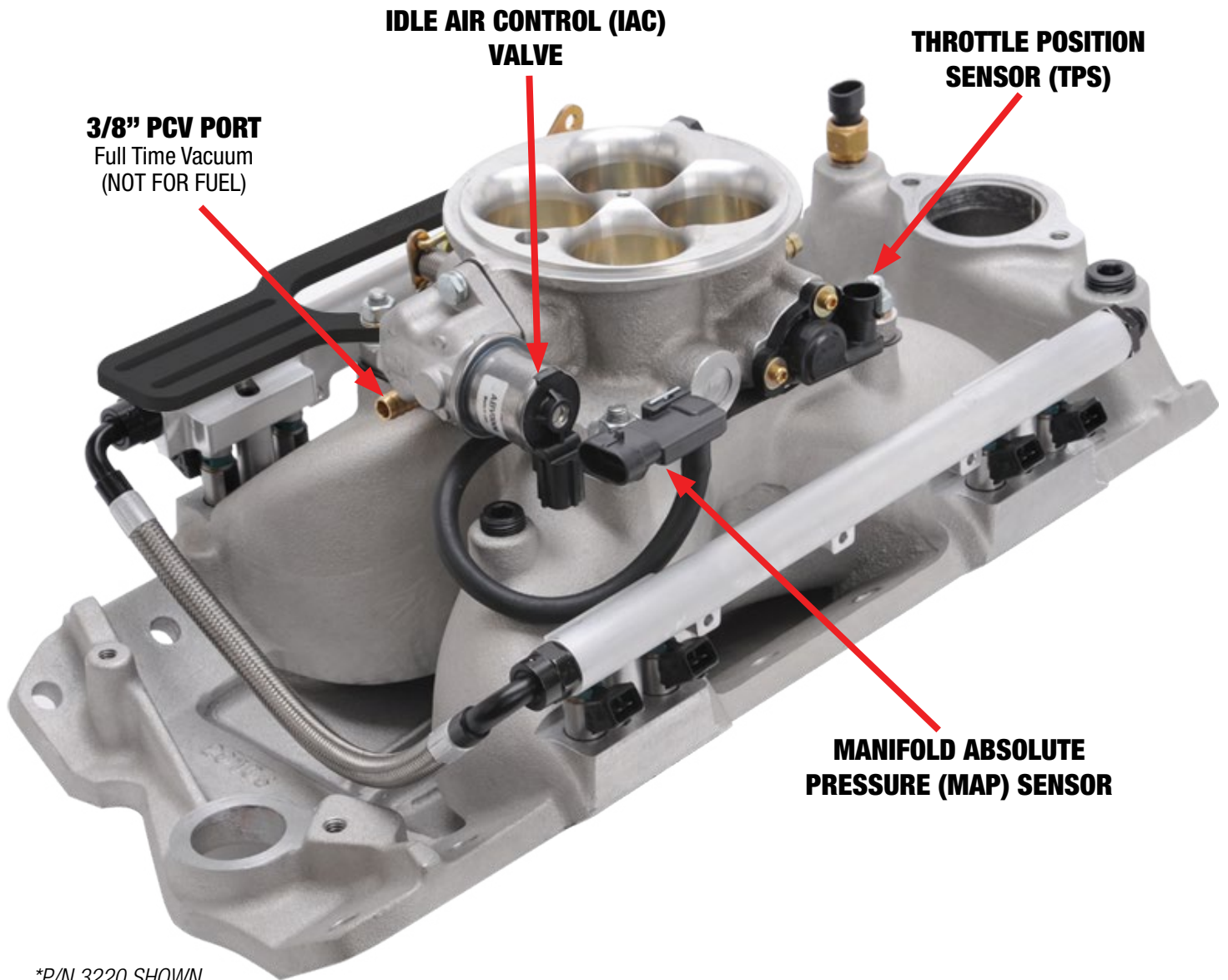

PRO-FLO 3 XT MANIFOLD - COMPONENT LAYOUT

The Edelbrock Pro-Flo 3 XT EFI system delivers fuel and air to the engine via an induction system consisting primarily of a traditional 90mm throttle body, dual fuel rails, and eight fuel injectors. The induction system is fully assembled, tested, pressure checked, and flowed at the Edelbrock Factory in Torrance, California. Avoid disassembling these components if possible.

NOTE: ALL UNUSED VACUUM PORTS MUST BE CAPPED TO AVOID VACUUM LEAKS

*P/N 32273 SHOWN

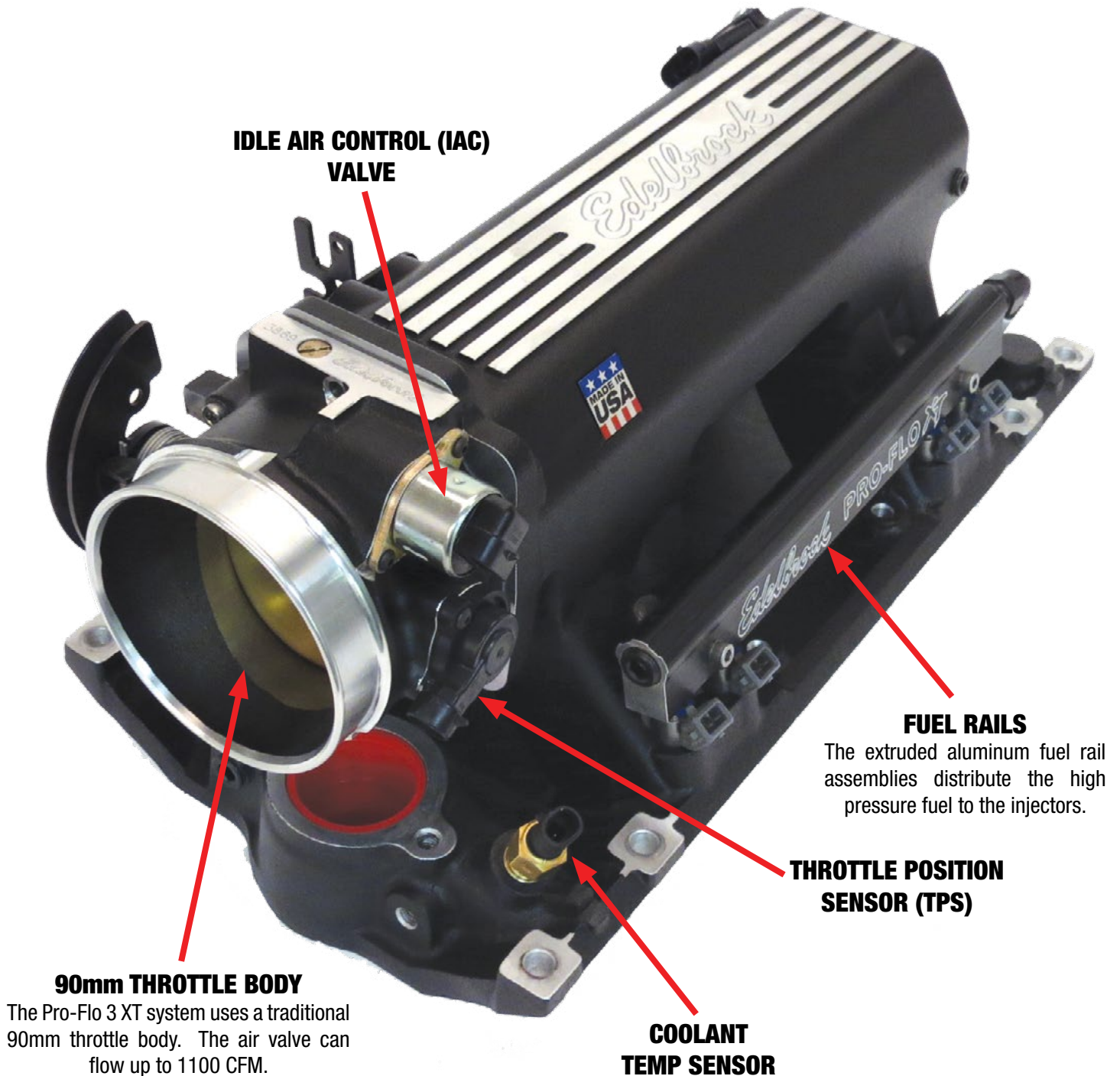

PRO-FLO 3 XT MANIFOLD - COMPONENT LAYOUT CON'T

*P/N 32273 SHOWN

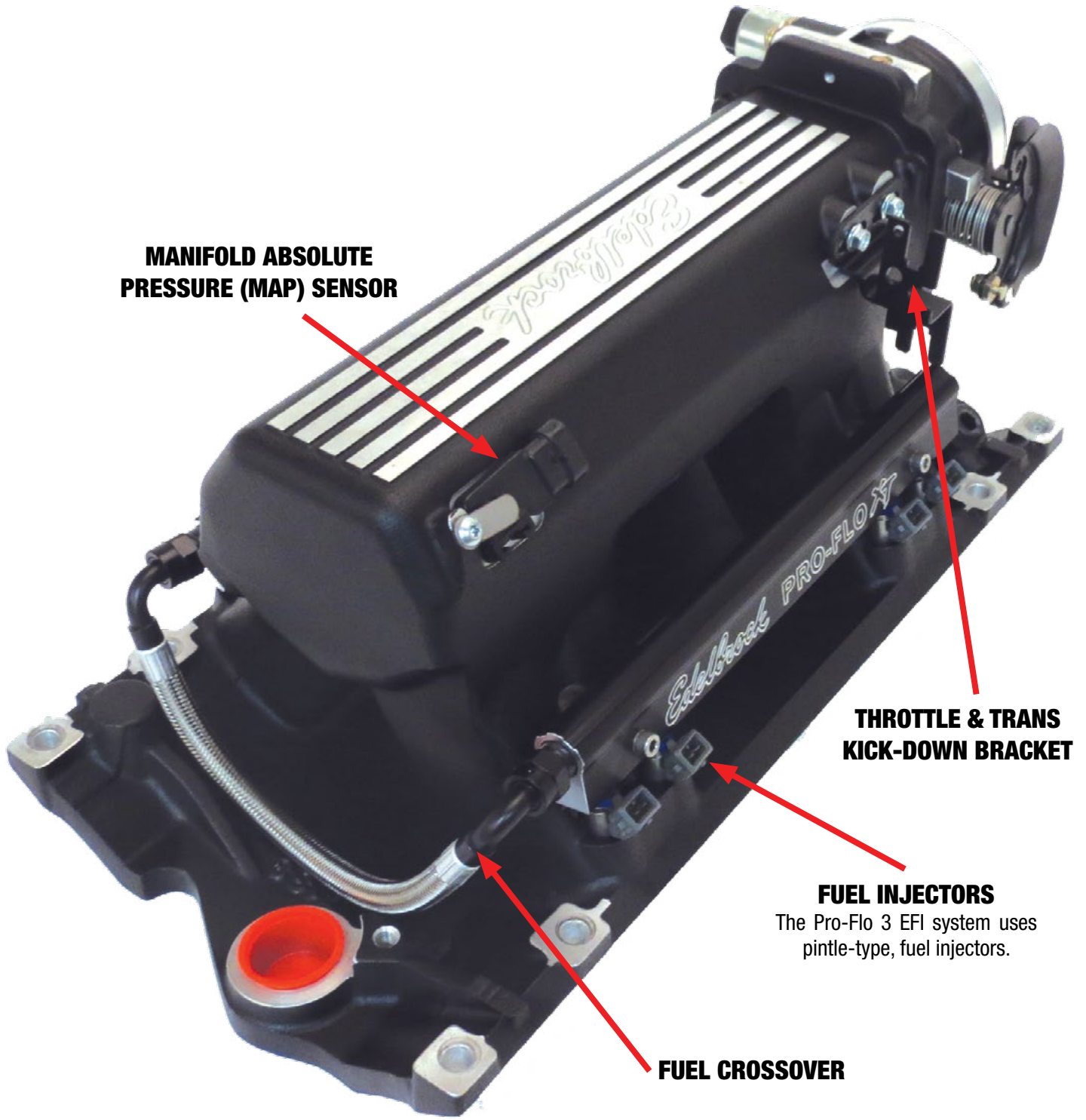

**MANIFOLD ABSOLUTE
PRESSURE (MAP) SENSOR**

**THROTTLE & TRANS
KICK-DOWN BRACKET**

FUEL INJECTORS
The Pro-Flo 3 EFI system uses
pintle-type, fuel injectors.

FUEL CROSSOVER

MAIN HARNESS LAYOUT

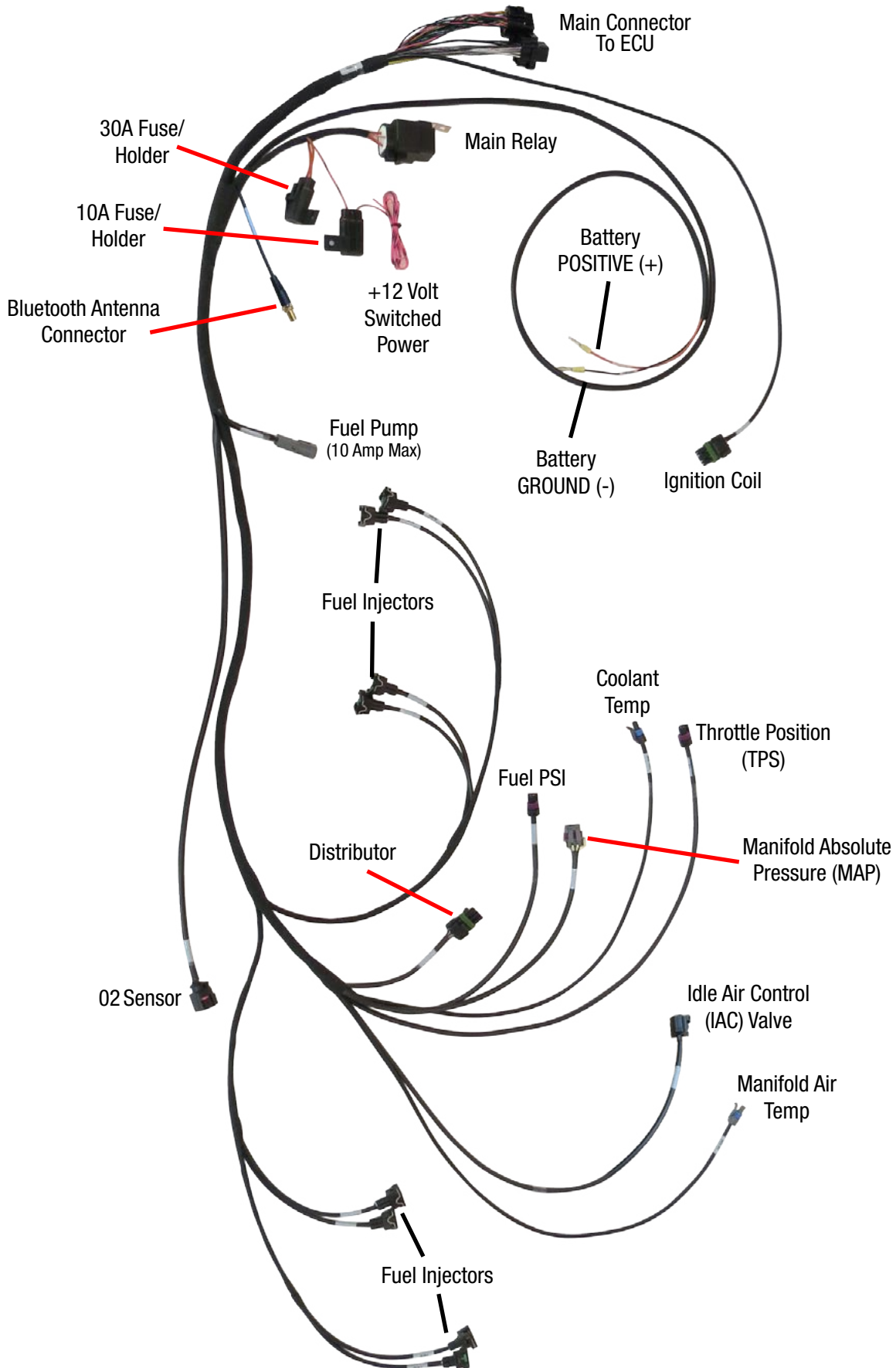

WIDEBAND OXYGEN (O2) SENSOR INSTALLATION PROCEDURE

The O2 sensor must be installed in the exhaust system using the supplied O2 sensor bung from the hardware bag. The O2 sensor is required as it measures the oxygen content of the exhaust gas, which is used by the ECU to manage fuel delivery under closed loop control.

NOTE: It is suggested that the O2 sensor bung be installed by a professional muffler shop prior to the installation of the Edelbrock Pro-Flo 3 EFI system. DO NOT drive the vehicle with the O2 sensor unplugged as this will damage the O2 sensor. An O2 sensor bung plug is provided for your convenience.

Because of harness length constraints, it is highly recommended to install the O2 sensor and the Pro-Flo 3 ECU on the same side of the vehicle.

WARNING: A properly sealed exhaust system is critical for the Pro-Flo 3 EFI to function properly. Any air leaks in the exhaust system, upstream of the O2 sensor, will skew the O2 sensor's output resulting in improper calibration which can lead to engine damage. Improper installation of the O2 sensor and any damage that may result is not covered by any Edelbrock Warranty.

1. Verify that the header and tailpipe gaskets and flanges are in good condition. It is recommended to replace any damaged gaskets and flanges as they may cause exhaust leaks, which can lead to inaccurate Air Fuel Ratio (AFR) readings. Torque all fasteners to manufacturer's specifications to avoid any possible exhaust leaks.

WARNING: Be sure any RTV Silicone used to seal the exhaust system is compatible with Oxygen Sensors. This information will be found on the silicone tube packaging.

WARNING: The Exhaust system must be completely sealed from cylinder head to tailpipe. This is the number one cause of poor performance.

2. The O2 sensor bung must be installed in the exhaust system as close to the engine as possible, after the header collector and before the catalytic converter (if equipped). This location must be approximately 10° above horizontal and within reach of the O2 sensor harness connector on the Pro-Flo 3 main harness.

3. Mark the drilling location on the exhaust system pipe with a permanent or paint marker. Check the proposed mounting location to ensure the clearance for the O2 sensor is adequate and that the O2 sensor connector on the main harness will reach the O2 sensor location. Make sure to take engine movement into consideration when checking for clearance.

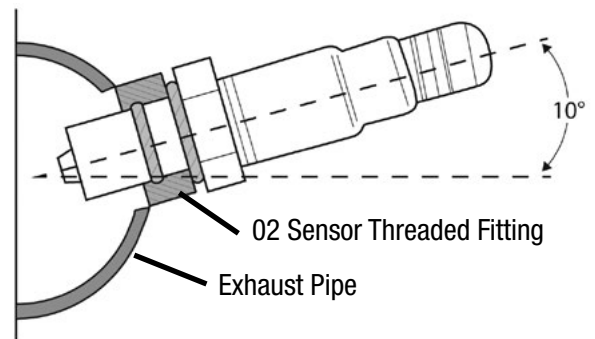

4. Drill a 5/8" hole at your mounting location. Deburr and clean the hole as needed.
5. Fit the provided bung onto the hole opening. Secure the bung with a clamp and weld the bung into place.

6. Once the installation of the bung is complete, make sure to clean the threads of the fitting to ensure it's free of debris.

NOTE: The O2 sensor bung uses an M18 x 1.5 thread pitch.

7. If you are ready to install the Pro-Flo 3 EFI system, proceed to Step #9 to install your O2 sensor. Otherwise, if your Pro-Flo 3 EFI System will be installed at a later time, temporarily install the O2 sensor bung plug supplied in the hardware bag with a 7/8" wrench. This will allow you to drive the vehicle until the O2 sensor is installed.
8. When you are ready to begin installation of the Pro-Flo 3 EFI system, remove the O2 sensor bung plug.
9. Apply a high-heat anti-seize compound (*not included*) to the threads of the O2 sensor and install into the bung using an 7/8" oxygen sensor socket or 7/8" wrench. **NOTE:** Avoid contacting tip of O2 Sensor with any anti seize compound, damage may occur.
10. Connect the O2 sensor to the O2 sensor connector on the main Pro-Flo 3 ECU harness.

DETERMINING HOOD CLEARANCE

1. Prior to installing the Pro-Flo 3 EFI system, it is highly recommended to verify that you will have enough hood clearance.
2. Using modeling clay or putty, not included, make five small cones about 2-3 inches high.
3. Position the cones on the air cleaner at front, rear, each side, and on the center stud.
4. Close the hood to locked position and re-open.
5. The height of the cones indicate the amount of clearance between the hood and the air cleaner. Record these measurements.

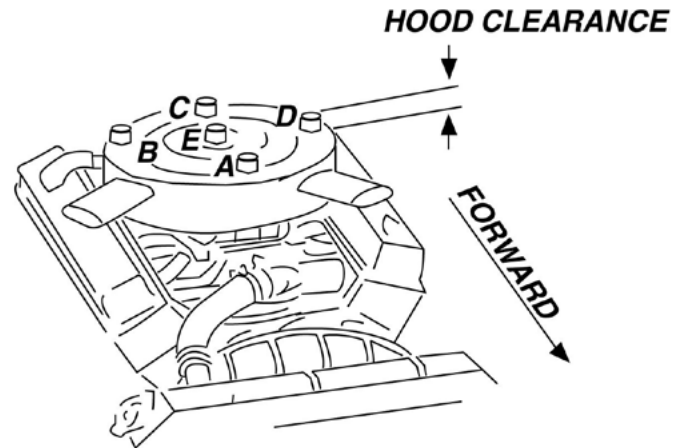
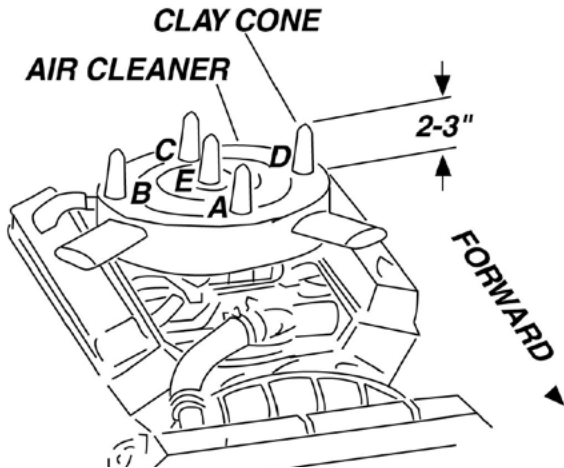

MANIFOLD & CARBURETOR HEIGHT VS. PRO-FLO 3 HEIGHT

1. Remove the factory air cleaner.
2. Lay a straightedge, such as a yardstick, across the top of the carburetor from front to back.
3. Measure from the base of the manifold end seal surfaces to the straightedge.
4. Record these measurements (height A and height B).
5. Add height A and height B and divide by two to get the average height. Ex: $(A+B) / 2$
6. Measure the Pro-Flo 3 system from the base of the manifold to the top of the throttle body or the highest point of the manifold (XT models).
7. Compare the two measurements. If the Pro-Flo 3 unit is taller, subtract the difference from the hood clearance figure to determine the new hood clearance.

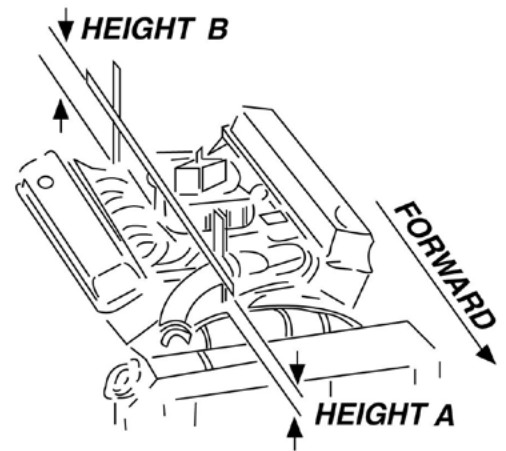

CAUTION: Because of engine torque, it is recommended to maintain at least 1/2-inch of clearance between the hood and air cleaner. If hood clearance is insufficient, a low profile air cleaner may solve the problem.

PRO-FLO 3 EFI INSTALLATION

NOTE: Though visually different, the installation procedure is relatively the same between manifolds using 4150 style throttle bodies and XT type throttle bodies.

1. Disconnect the battery. Drain the radiator coolant (radiator drain plug is typically located on lower right facing engine). **WARNING! Do NOT drain coolant while engine is hot.**
2. Remove the gas cap to release any fuel pressure present in the system. Remove the air cleaner, throttle linkage, vacuum and fuel line from the carburetor. Remove all brackets and the radiator hose (if applicable) from the intake manifold. **TIP:** Tag all linkages, vacuum and fuel lines. This will simplify the installation.
3. Rotate the engine to 12° Before Top Dead Center (BTDC) on the compression stroke of cylinder #1.
4. Remove the distributor hold down clamp and remove the distributor from the engine.
5. Clean all debris from the intake manifold and unbolt the carburetor and intake manifold. **NOTE:** Removal of the valve covers may be required on some applications. If valve covers are removed, replace the valve cover gaskets as needed.
6. Place rags or paper towels into the cylinder head ports and lifter valley to prevent debris from falling into the ports and combustion chambers.
7. Remove the gaskets and gasket residue using a metal scraper. Vacuum up any debris before proceeding.
8. Remove the rags or paper towels from the cylinder head ports. Using a shop rag and lacquer thinner, clean the head/manifold mating surface.
9. Test fit manifold to cylinder heads to verify fit and that there are no interferences.
10. Apply two (2) thin layers of Gasgacinch to the head/manifold mating surface (Figure 1) and one (1) side of the supplied intake manifold gaskets (Figure 2). Let the Gasgacinch tack up for about one (1) minute.



11. Position the intake manifold gaskets (side with Gasgacinch) onto the cylinder heads making sure to align the intake ports. Press down firmly to secure (Figure 3).
12. Using finger, apply a thin layer of gasket maker around the intake ports and a slightly thicker layer around the water jackets (Figure 4). Do this for both intake manifold gaskets.

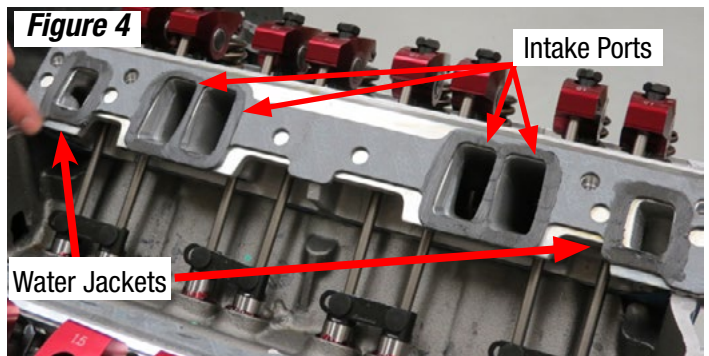

13. Apply a bead of gasket maker about a 1/4" thick to the front and rear of the block as shown (Figure 5).

14. Wipe down the intake manifold's mating surface with lacquer thinner (Figure 5). Carefully position the intake manifold onto the cylinder heads.



15. Torque all manifold bolts in a criss cross pattern starting with the inner bolts and working outwards. Refer to the vehicle's service manual for proper torque spec and procedures.
NOTE: On most applications, removal of fuel rails prior to installing the manifold assembly is not required.
16. Reinstall the valve covers if removed. Attach the throttle linkage and verify it moves freely without interference. Any throttle linkage interference **MUST** be resolved before proceeding.
17. Verify the engine is still positioned at 12 degrees before top dead center with cylinder #1 on a compression stroke.
18. Install the gasket onto the distributor housing and apply a liberal amount of lubricant to the distributor gear.
19. Install the Edelbrock Pro-Flo distributor so that the rotor is pointed in the proximity of the #1 stamped on the outside of the distributor housing and the short trigger tooth is just entering the distributor sensor.
NOTE: You may need to remove and reinsert the distributor a few times to get the alignment correct. Make sure that the distributor seats down completely and has full engagement with the oil pump drive. You may need to rotate the oil pump shaft to ensure it is engaged properly.
20. Tighten the hold down clamp leaving it just loose enough that you can rotate the distributor during the timing procedure. The final timing will be set using the E-Tuner Android app.

**DISTRIBUTOR ROTOR LOCATION AT INSTALLATION POINTING TO #1 ON SIDE OF HOUSING WITH ENGINE AT 12° BTDC
CYLINDER #1 ON COMPRESSION STROKE.**

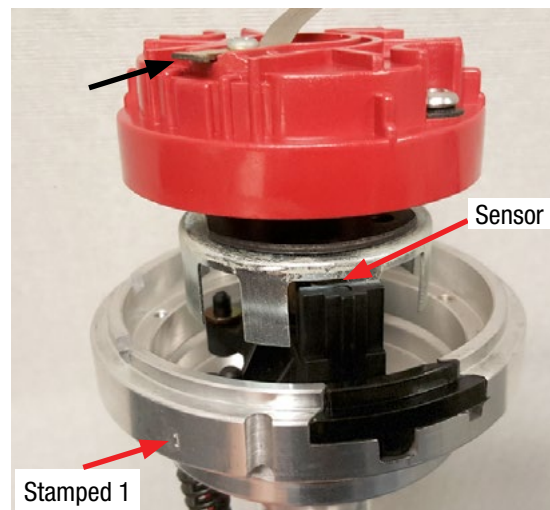

DISTRIBUTOR CONNECTION - Connect the 3 pin distributor connector to Pro Flo 3 Main Harness connector labeled DIST. Ford and some Chrysler applications with distributor located at front of engine will use the provided Distributor Lead extension harness.

COIL CONNECTION W/ CDI BOX - Cut off the eye terminal on the white wire of the provided Ignition Coil harness. Connect the WHITE lead to the WHITE negative trigger wire on the CDI box (refer to the diagrams on Page 5). **CAUTION: De-pin the orange wire from the two pin connector and remove wire from vinyl sleeve and discard.** Connect the modified Ignition Coil Harness to the E-Street Main Harness connector labeled Coil. Connect the Hi Voltage Coil Wires from CDI box to Coil.

21. Install the spark plug wires, refer to page #20 for firing order for your application. Position cylinder 1 spark plug wire on the distributor cap post located at the 1 stamped on the distributor housing.

22. Find a suitable mounting location for the ECU. This should be on the same side of the vehicle as the O2 sensor. Recommended mounting locations are the fender well, inner fender panel or inside the vehicle on the passenger side kick panel. Be sure the O2 sensor connection reaches the main harness connector.
NOTE: *It is recommended to mount the ECU in a location away from excess heat, vibration and possible water exposure.*
23. Using the supplied rubber washers and sheet metal screws from hardware bag, mount the ECU to the desired mounting location. The rubber washers must be used in between the mounting surface and the ECU to help absorb excessive vibration.
24. Find a suitable harness route in the engine compartment which leads to the ECU location. Connect the Pro-Flo 3 main harness to the ECU. TIP: For most installations, the harness fits best if routed from the rear of the engine back towards the firewall, across the firewall, then forward towards the ECU location.
NOTE: *Avoid routing the harness near any ignition related components (ignition coil, distributor, spark plug wires). Also avoid routing near the headers, sharp edges, or any tight radius corners that may damage the harness.*
25. Route the power and ground leads on the main harness towards the battery. Connect the RED POWER lead (+12 Volt) and the BLACK GROUND (-) lead to the appropriate battery terminals. If necessary, the power and ground leads may be extended to reach the battery. However, the use of 12 gauge wire or larger is required.
WARNING: *All power and ground leads must connect directly to the battery.*
26. Securely mount the Fuse Holders and the Main Relay in an accessible location.
27. Connect the Pink/Black +12 Volt switched wire on the main harness to a +12 Volt switched power source that provides +12 Volts when the key is both "ON" and "CRANKING".
NOTE: *It is critical that the switched +12 Volt is constant during cranking. This is a common issue on vehicles with no start or hard to start issues. Do not connect this to the positive side of the coil.*
28. Mount the magnetic Bluetooth antenna base inside the vehicle, preferably underneath the dash and towards the center of the vehicle. Screw the antenna to the antenna base and connect the antenna cable to the main harness.
NOTE: *It may be required to drill a 5/16" hole in the firewall to route the antenna cable to the Pro-Flo 3 main harness. If doing so, use the supplied grommet from hardware bag to protect the antenna cable.*
29. Secure the harness and leads with tie wraps from the hardware bag. Avoid over tensioning wire ties as this may damage the harness.
30. If not already completed, remove the previously installed O2 sensor bung plug from the bung in the exhaust system, and install the O2 sensor.
NOTE: *Make sure to apply a high heat anti-seize compound to the threads of the O2 sensor as recommended in the O2 Sensor installation section. Avoid contacting tip of O2 Sensor with any anti seize compound, damage may occur.*
31. Connect the main harness lead labeled "O2 Sensor" to the O2 sensor connector. Secure the O2 sensor lead as to avoiding contact with the exhaust pipes. Make sure to leave plenty of air space between the harness and the exhaust manifolds/headers.
32. Due to the universal nature of the Pro-Flo 3 EFI system, it's impossible to preset the throttle blades to best fit all the different possible idle characteristics of engine and cam size combination. To help the engine idle during initial startup, it is recommended to adjust the throttle screw as needed to keep the engine from stalling.
 - Street/Stock Cam (210° or Less): Turn (clockwise) the throttle screw 1/2 turn from the current factory setting.
 - Mild Cam (210° or 230°): Turn (clockwise) the throttle screw 1 additional turn from the current factory setting.
 - Race Cam (230° or Greater): Turn (clockwise) the throttle screw 1.5 turns from the current factory setting.
33. Install the throttle return spring and bracket from hardware bag. Manifold bolt locations are ideal mounting points.
34. INSTALL THE FUEL DELIVERY SYSTEM. Please refer to the fuel system's installation instructions then return to this manual and continue to Step 37.
35. Once the Pro-Flo 3 EFI System and the fuel delivery system have been installed, continue to the Quick Reference Guide to setup the Edelbrock E-Tuner Setup Wizard to complete your installation.
36. If you are supplying your own tablet or smartphone, you can download the Edelbrock E-Tuner app on the Google Play Store. Just search for Edelbrock E-Tuner and download the app like any other Android app.

WARNING: DO NOT START OR DRIVE THE VEHICLE UNTIL PROMPTED TO DO SO BY THE E-TUNER SETUP WIZARD. A PROPER BASE MAP CALIBRATION MUST BE LOADED TO THE Pro-Flo 3 ECU BEFORE STARTING THE VEHICLE. REFER TO THE QUICK START GUIDE TO PROPERLY LOAD A BASE MAP INTO YOUR Pro-Flo 3 ECU.

FAN & A/C TRIGGER INSTALLATION

Three pigtail leads are provided in hardware bag to trigger the electric fan(s) and A/C kick up, if so equipped. The Fan trigger outputs from the ECU are low current switched GROUND(S) that require a 30 AMP Automotive Relay (not included) for each output.

NOTE: DO NOT connect Pro-Flo 3 ECU fan outputs directly to fan motors. DO NOT connect A/C compressor clutch switch directly to the Pro-Flo 3 ECU. DAMAGE TO ECU WILL OCCUR.

The diagrams provided on Page #14 are to assist in the connection of the programmable switched trigger outputs for electric fans and AC kick up using the provide pigtails (*not pre-installed*). The Pro-Flo 3 EFI uses low voltage switched ground outputs for electric fan triggers and a switched ground AC kick up input. These triggers are controlled by the ECU using parameters defined in the E-Tuner software. The pinouts for the fan outputs are: Pin 16 on the 34 pin connector - Fan #1 and Pinout 34 on the 34 pin connector - Fan #2 (*See Pinout Diagram on Main Harness Schematic*). The AC kick up trigger, Pinout 22 on the 34 pin connector, is a ground input used to bump the idle when the AC is switched on. The Fan trigger(s) and AC kick up trigger must be used in conjunction with a 30 AMP automotive relay (*not included*). Each accessory trigger will require its own 30 AMP automotive relay.

NOTE: Auxiliary Outputs are rated at 1.5 AMP max and must be configured to activate with a relay (not included). DO NOT connect ECU fan outputs directly to the fans. DO NOT connect AC compressor clutch switch directly to the Pro-Flo 3 ECU.

PIGTAIL INSTALLATION

To install the provided pigtails, use a small flathead screwdriver to push in the large locking tab (Image A). Remove the white cavity plug. Insert the pigtail(s) to the appropriate pinout(s), on the harness side of the connector, until the pigtail is fully seated. When complete, push down on the two small tabs to re-lock the locking tab (Image B).

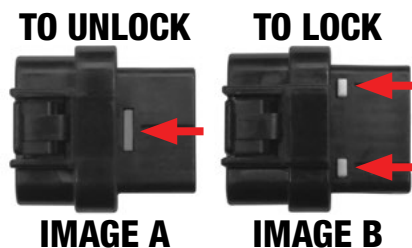

FAN & A/C TRIGGER DIAGRAM

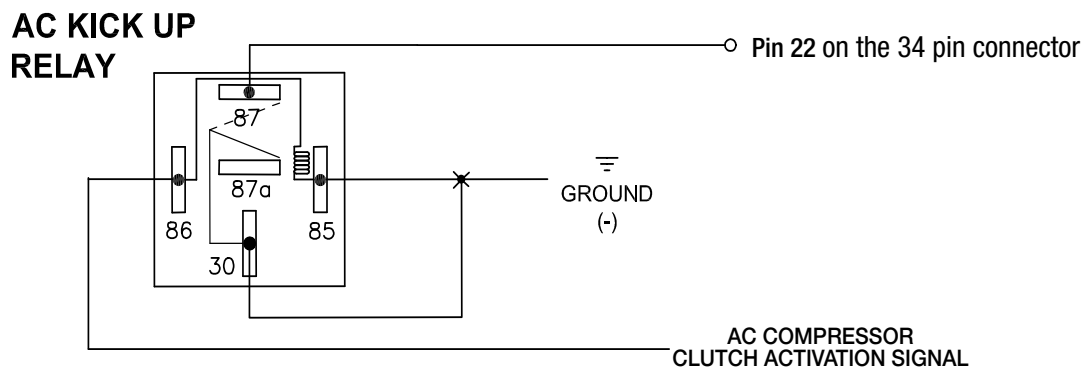
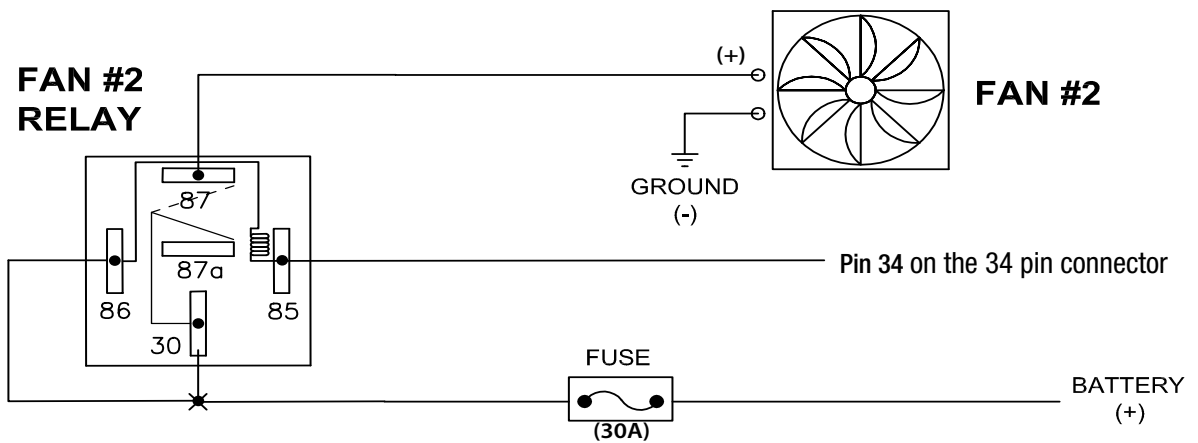
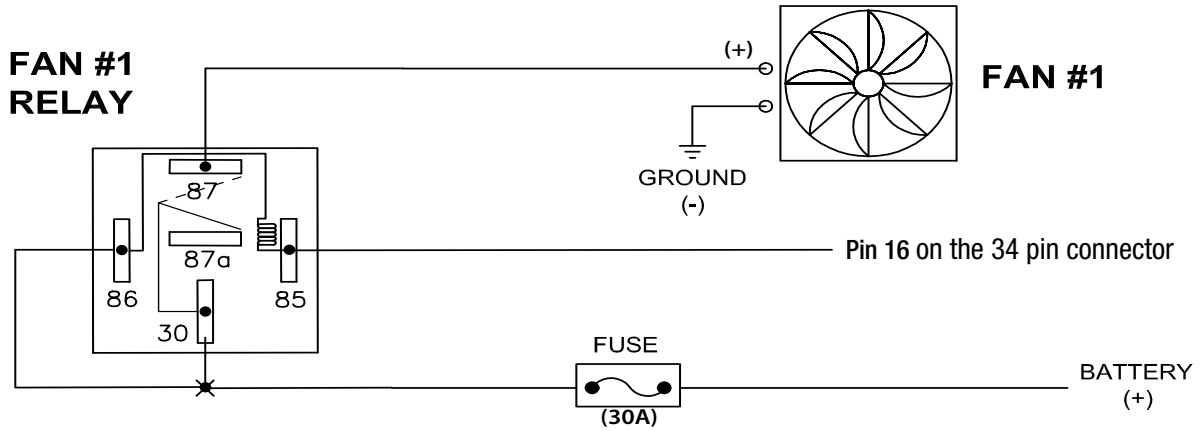

WIRING W/ PRO-FLO DISTRIBUTOR & CDI BOX

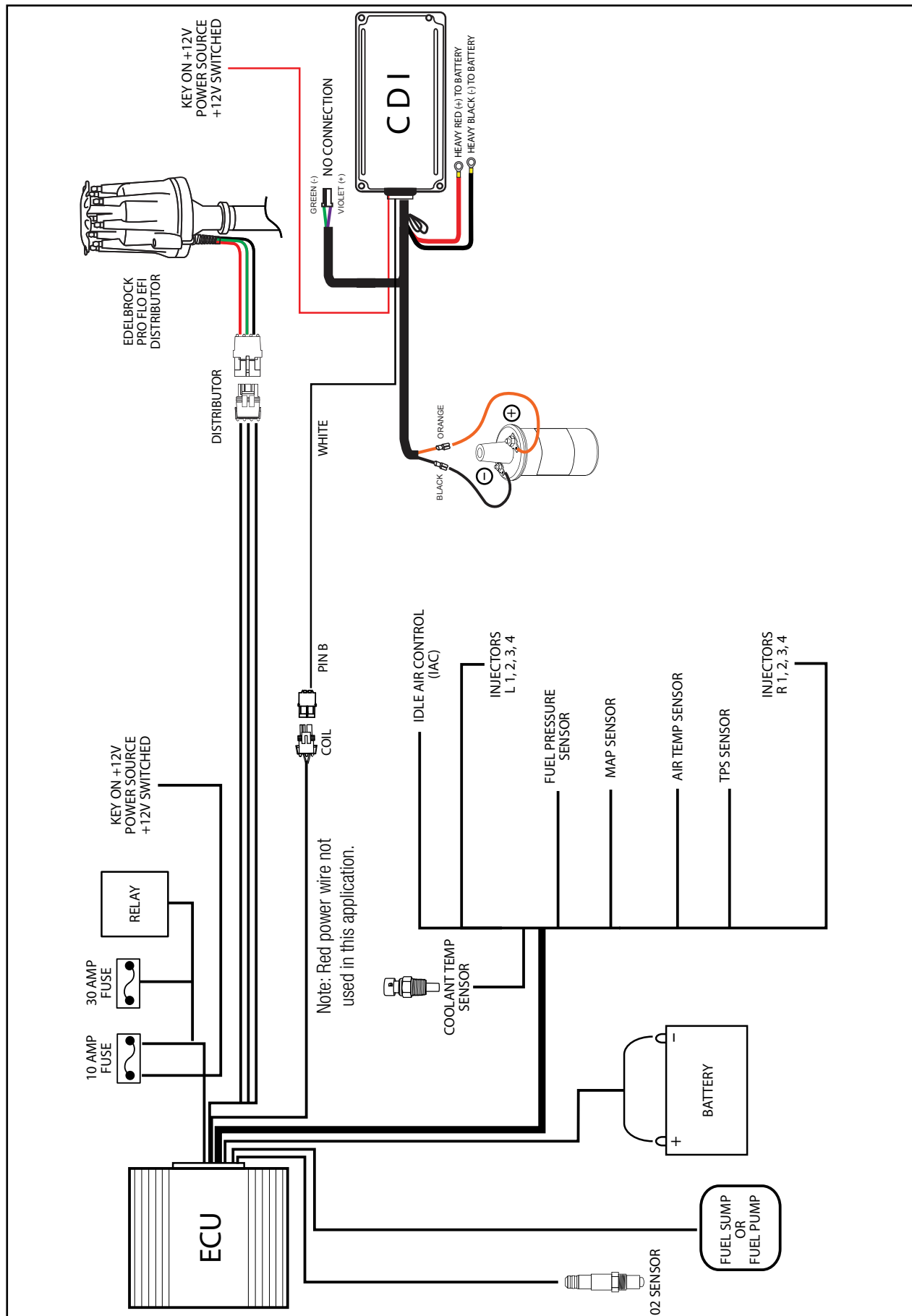

MAIN HARNESS SCHEMATIC

Refer to Page 19 for specific injector firing order configurations.

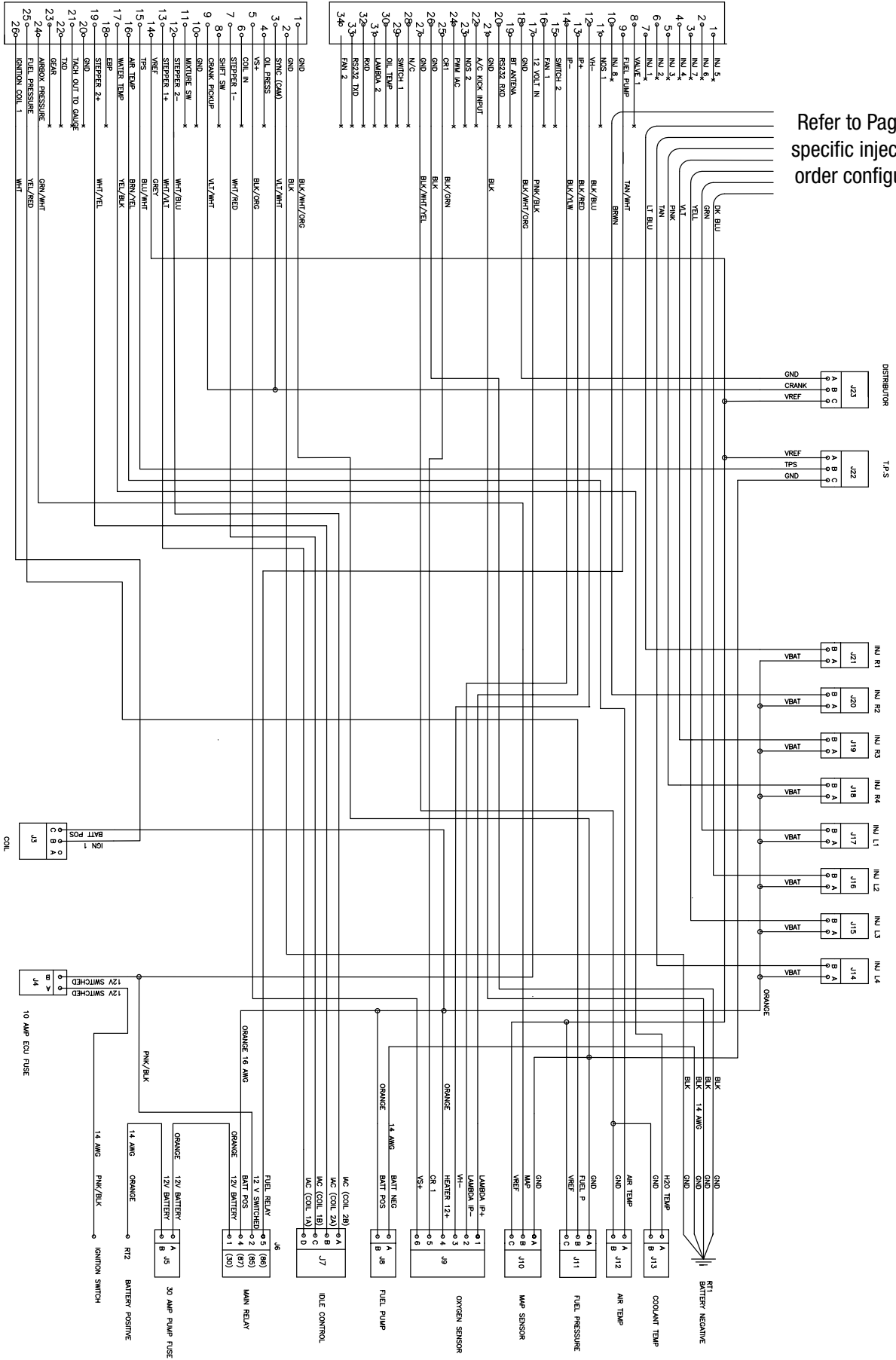

INJECTOR FIRING ORDER CONFIGURATIONS

NOTE: See Page 23 for OEM firing orders.

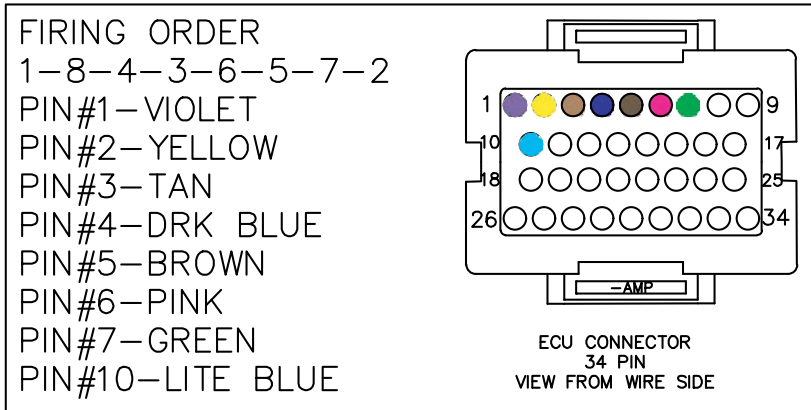
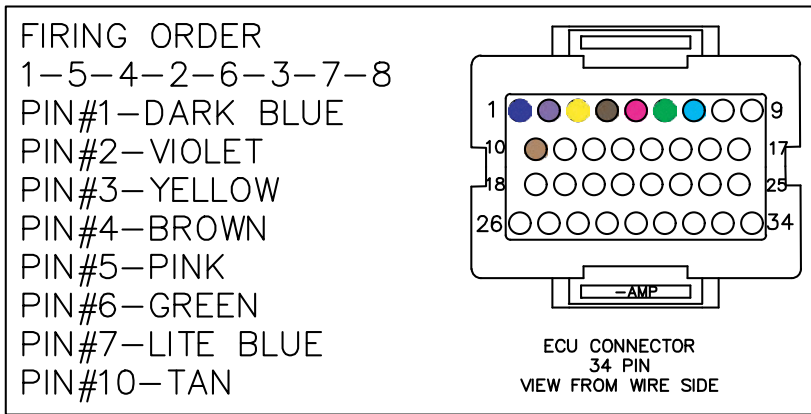
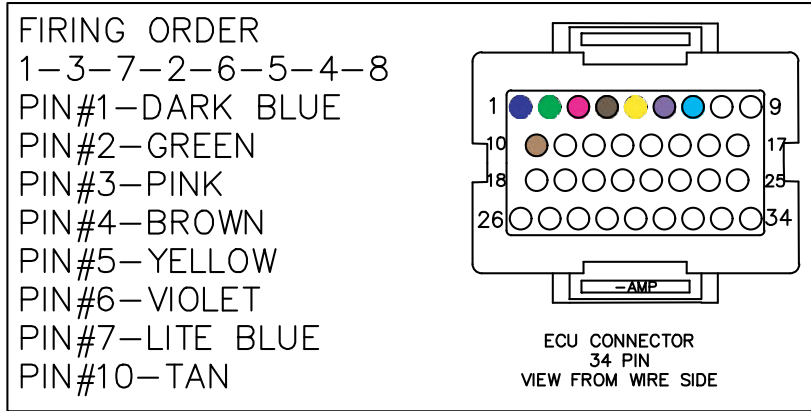

34 PIN LCU CONNECTOR

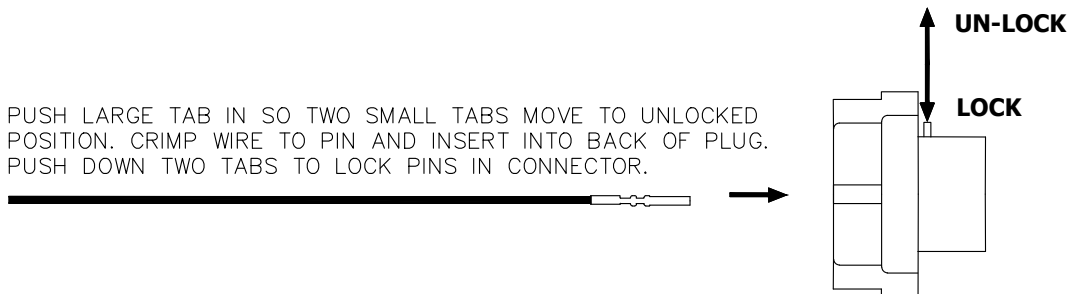

*Diagram is for reference only. The main harness is pre terminated for the specific application.

PRO FLO 3 EFI SETUP WIZARD MAP MATRIX

CAL. I.D	FUEL SYSTEM TYPE	CUBIC INCHES RANGE	CATEGORY	CAMSHAFT DURATION @ 0.050 LIFT	GAUGE PRESSURE. IDLE VACUUM	INJECTOR SIZE	HP Level
32200	RETURN/SUMP 43 PSI	280-330	STOCK	210 OR LESS	20.0 - 16.0	29	400
42200XT	RETURN/SUMP 43 PSI	280-330	STOCK	210 OR LESS	20.0 - 16.0	29	400
32201	RETURN/SUMP 58 PSI	280-330	STOCK	210 OR LESS	20.0 - 16.0	29	450
42201XT	RETURN/SUMP 58 PSI	280-330	STOCK	210 OR LESS	20.0 - 16.0	29	450
32202	RETURN/SUMP 43 PSI	280-330	MILD	210 TO 230 DEG.	16.0 - 12.0	29	400
42202XT	RETURN/SUMP 43 PSI	280-330	MILD	210 TO 230 DEG.	16.0 - 12.0	29	400
32203	RETURN/SUMP 58 PSI	280-330	MILD	210 TO 230 DEG.	16.0 - 12.0	29	450
42203XT	RETURN/SUMP 58 PSI	280-330	MILD	210 TO 230 DEG.	16.0 - 12.0	29	450
32204	RETURN/SUMP 43 PSI	280-330	RACE	230 OR GREATER	12.0 - 5.0	29	400
42204XT	RETURN/SUMP 43 PSI	280-330	RACE	230 OR GREATER	12.0 - 5.0	29	400
32205	RETURN/SUMP 58 PSI	280-330	RACE	230 OR GREATER	12.0 - 5.0	29	450
42205XT	RETURN/SUMP 58 PSI	280-330	RACE	230 OR GREATER	12.0 - 5.0	29	450
32206	RETURN/SUMP 43 PSI	331-380	STOCK	210 OR LESS	20.0 - 16.0	29	400
42206XT	RETURN/SUMP 43 PSI	331-380	STOCK	210 OR LESS	20.0 - 16.0	29	400
32207	RETURN/SUMP 58 PSI	331-380	STOCK	210 OR LESS	20.0 - 16.0	29	450
42207XT	RETURN/SUMP 58 PSI	331-380	STOCK	210 OR LESS	20.0 - 16.0	29	450
32208	RETURN/SUMP 43 PSI	331-380	MILD	210 TO 230 DEG.	16.0 - 12.0	29	400
42208XT	RETURN/SUMP 43 PSI	331-380	MILD	210 TO 230 DEG.	16.0 - 12.0	29	400
32209	RETURN/SUMP 58 PSI	331-380	MILD	210 TO 230 DEG.	16.0 - 12.0	29	450
42209XT	RETURN/SUMP 58 PSI	331-380	MILD	210 TO 230 DEG.	16.0 - 12.0	29	450
32210	RETURN/SUMP 58 PSI	331-380	RACE	230 OR GREATER	12.0 - 5.0	29	450
42210XT	RETURN/SUMP 58 PSI	331-380	RACE	230 OR GREATER	12.0 - 5.0	29	450
32211	RETURN/SUMP 43 PSI	331-380	STOCK	210 OR LESS	20.0 - 16.0	35	450
42211XT	RETURN/SUMP 43 PSI	331-380	STOCK	210 OR LESS	20.0 - 16.0	35	450
32212	RETURN/SUMP 58 PSI	331-380	STOCK	210 OR LESS	20.0 - 16.0	35	550
42212XT	RETURN/SUMP 58 PSI	331-380	STOCK	210 OR LESS	20.0 - 16.0	35	550
32213	RETURN/SUMP 43 PSI	331-380	MILD	210 TO 230 DEG.	16.0 - 12.0	35	450
42213XT	RETURN/SUMP 43 PSI	331-380	MILD	210 TO 230 DEG.	16.0 - 12.0	35	450

CAL. I.D	FUEL SYSTEM TYPE	CUBIC INCHES RANGE	CATEGORY	CAMSHAFT DURATION @ 0.050 LIFT	GAUGE PRESSURE. IDLE VACUUM	INJECTOR SIZE	HP Level
32214	RETURN/SUMP 58 PSI	331-380	MILD	210 TO 230 DEG.	16.0 - 12.0	35	550
42214XT	RETURN/SUMP 58 PSI	331-380	MILD	210 TO 230 DEG.	16.0 - 12.0	35	550
32215	RETURN/SUMP 43 PSI	331-380	RACE	230 OR GREATER	12.0 - 5.0	35	450
42215XT	RETURN/SUMP 43 PSI	331-380	RACE	230 OR GREATER	12.0 - 5.0	35	450
32216	RETURN/SUMP 58 PSI	331-380	RACE	230 OR GREATER	12.0 - 5.0	35	550
42216XT	RETURN/SUMP 58 PSI	331-380	RACE	230 OR GREATER	12.0 - 5.0	35	550
32217	RETURN/SUMP 43 PSI	381-405	STOCK	210 OR LESS	20.0 - 16.0	29	400
42217XT	RETURN/SUMP 43 PSI	381-405	STOCK	210 OR LESS	20.0 - 16.0	29	400
32218	RETURN/SUMP 58 PSI	381-405	STOCK	210 OR LESS	20.0 - 16.0	29	450
42218XT	RETURN/SUMP 58 PSI	381-405	STOCK	210 OR LESS	20.0 - 16.0	29	450
32219	RETURN/SUMP 58 PSI	381-405	MILD	210 TO 230 DEG.	16.0 - 12.0	29	450
42219XT	RETURN/SUMP 58 PSI	381-405	MILD	210 TO 230 DEG.	16.0 - 12.0	29	450
32220	RETURN/SUMP 58 PSI	381-405	RACE	230 OR GREATER	12.0 - 5.0	29	450
42220XT	RETURN/SUMP 58 PSI	381-405	RACE	230 OR GREATER	12.0 - 5.0	29	450
32221	RETURN/SUMP 43 PSI	381-405	STOCK	210 OR LESS	20.0 - 16.0	35	450
42221XT	RETURN/SUMP 43 PSI	381-405	STOCK	210 OR LESS	20.0 - 16.0	35	450
32222	RETURN/SUMP 58 PSI	381-405	STOCK	210 OR LESS	20.0 - 16.0	35	550
42222XT	RETURN/SUMP 58 PSI	381-405	STOCK	210 OR LESS	20.0 - 16.0	35	550
32223	RETURN/SUMP 43 PSI	381-405	MILD	210 TO 230 DEG.	16.0 - 12.0	35	450
42223XT	RETURN/SUMP 43 PSI	381-405	MILD	210 TO 230 DEG.	16.0 - 12.0	35	450
32224	RETURN/SUMP 58 PSI	381-405	MILD	210 TO 230 DEG.	16.0 - 12.0	35	550
42224XT	RETURN/SUMP 58 PSI	381-405	MILD	210 TO 230 DEG.	16.0 - 12.0	35	550
32225	RETURN/SUMP 58 PSI	381-405	RACE	230 OR GREATER	12.0 - 5.0	35	550
42225XT	RETURN/SUMP 58 PSI	381-405	RACE	230 OR GREATER	12.0 - 5.0	35	550
32226	RETURN/SUMP 43 PSI	406-439	STOCK	210 OR LESS	20.0 - 16.0	35	450
42226XT	RETURN/SUMP 43 PSI	406-439	STOCK	210 OR LESS	20.0 - 16.0	35	450
32227	RETURN/SUMP 58 PSI	406-439	STOCK	210 OR LESS	20.0 - 16.0	35	550
42227XT	RETURN/SUMP 58 PSI	406-439	STOCK	210 OR LESS	20.0 - 16.0	35	550
32228	RETURN/SUMP 43 PSI	406-439	MILD	210 TO 230 DEG.	16.0 - 12.0	35	450

CAL. I.D	FUEL SYSTEM TYPE	CUBIC INCHES RANGE	CATEGORY	CAMSHAFT DURATION @ 0.050 LIFT	GAUGE PRESSURE. IDLE VACUUM	INJECTOR SIZE	HP Level
42228XT	RETURN/SUMP 43 PSI	406-439	MILD	210 TO 230 DEG.	16.0 - 12.0	35	450
32229	RETURN/SUMP 58 PSI	406-439	MILD	210 TO 230 DEG.	16.0 - 12.0	35	550
42229XT	RETURN/SUMP 58 PSI	406-439	MILD	210 TO 230 DEG.	16.0 - 12.0	35	550
32230	RETURN/SUMP 58 PSI	406-439	RACE	230 OR GREATER	12.0 - 5.0	35	550
42230XT	RETURN/SUMP 58 PSI	406-439	RACE	230 OR GREATER	12.0 - 5.0	35	550
32231	RETURN/SUMP 43 PSI	440-480	STOCK	210 OR LESS	20.0 - 16.0	35	450
42231XT	RETURN/SUMP 43 PSI	440-480	STOCK	210 OR LESS	20.0 - 16.0	35	450
32232	RETURN/SUMP 58 PSI	440-480	STOCK	210 OR LESS	20.0 - 16.0	35	550
42232XT	RETURN/SUMP 58 PSI	440-480	STOCK	210 OR LESS	20.0 - 16.0	35	550
32233	RETURN/SUMP 58 PSI	440-480	MILD	210 TO 230 DEG.	16.0 - 12.0	35	550
42233XT	RETURN/SUMP 58 PSI	440-480	MILD	210 TO 230 DEG.	16.0 - 12.0	35	550
32234	RETURN/SUMP 58 PSI	440-480	RACE	230 OR GREATER	12.0 - 5.0	35	550
42234XT	RETURN/SUMP 58 PSI	440-480	RACE	230 OR GREATER	12.0 - 5.0	35	550
32235	RETURN/SUMP 58 PSI	481-510	STOCK	210 OR LESS	20.0 - 16.0	35	550
42235XT	RETURN/SUMP 58 PSI	481-510	STOCK	210 OR LESS	20.0 - 16.0	35	550
32236	RETURN/SUMP 58 PSI	481-510	MILD	210 TO 230 DEG.	16.0 - 12.0	35	550
42236XT	RETURN/SUMP 58 PSI	481-510	MILD	210 TO 230 DEG.	16.0 - 12.0	35	550
32237	RETURN 43 PSI	481-510	RACE	230 OR GREATER	12.0 - 5.0	60	800
42237XT	RETURN 43 PSI	481-510	RACE	230 OR GREATER	12.0 - 5.0	60	800
32238	RETURN 43 PSI	510-565	RACE	230 OR GREATER	12.0 - 5.0	60	800
42238XT	RETURN 43 PSI	510-565	RACE	230 OR GREATER	12.0 - 5.0	60	800

OEM FIRING ORDERS

AMC 304-401
FIRING ORDER
 1-8-4-3-6-5-7-2

FRONT OF ENGINE
↓

PONTIAC
 265, 301, 307, 326, 350
 389, 400, 421, 428, 455
FIRING ORDER
 1-8-4-3-6-5-7-2

FRONT OF ENGINE
↓

CHRYSLER / DODGE
 361, 383, 400, 413, 426, 426
 HEMI, 440
FIRING ORDER
 1-8-4-3-6-5-7-2

FRONT OF ENGINE
↓

CHRYSLER / DODGE
PLYMOUTH
 273, 318, 340, 360
FIRING ORDER
 1-8-4-3-6-5-7-2

FRONT OF ENGINE
↓

CHEVROLET
BIG & SMALL BLOCK
FIRING ORDER
 1-8-4-3-6-5-7-2

FRONT OF ENGINE
↓

CHEVROLET
LS SERIES
FIRING ORDER
 1-8-7-2-6-5-4-3

FRONT OF ENGINE
↓

FORD
 260, 289, 302, 429, 460,
 514, ALL FE
FIRING ORDER
 1-5-4-2-6-3-7-8

FRONT OF ENGINE
↓

FORD
 351W, 351C, 351M, 400,
 LATE 302
FIRING ORDER
 1-3-7-2-6-5-4-8

FRONT OF ENGINE
↓

WARRANTY

Edelbrock warrants the Edelbrock Pro-Flo 3 EFI system to be free from defects in both workmanship and materials for a period of one year from date of purchase, provided that the product is properly installed and subjected to normal use and service, is not used for racing or competition purposes and that the product is not modified or altered in any way unless specified by our instructions. Our warranty service and repair facility is located at 2700 California Street, Torrance, CA 90503. Customers requiring warranty assistance should contact the dealer from whom they purchased the product. In turn, the dealer will contact Edelbrock, and we will determine the method of satisfying the warranty. Should Edelbrock determine that the product needs to be returned to the factory, it should be accompanied by proof of purchase and a clear description of the exact problem. The product must be returned freight pre-paid. If a thorough inspection of the product by the factory indicates defects in workmanship or material, our sole obligation shall be to repair or replace the product. This warranty covers only the product itself and not the cost of installation or removal.

EDELBRICK LLC SHALL NOT BE LIABLE FOR ANY AND ALL CONSEQUENTIAL DAMAGES OCCASIONED BY THE BREACH OF ANY WRITTEN OR IMPLIED WARRANTY PERTAINING TO THIS SALE, IN EXCESS OF THE PURCHASE PRICE OF THE PRODUCT SOLD.

If you have any questions regarding this product or installation, please contact our Technical Department from 7:00 am - 5:00 pm, Pacific Standard Time, Monday through Friday at: 800-416-8628.

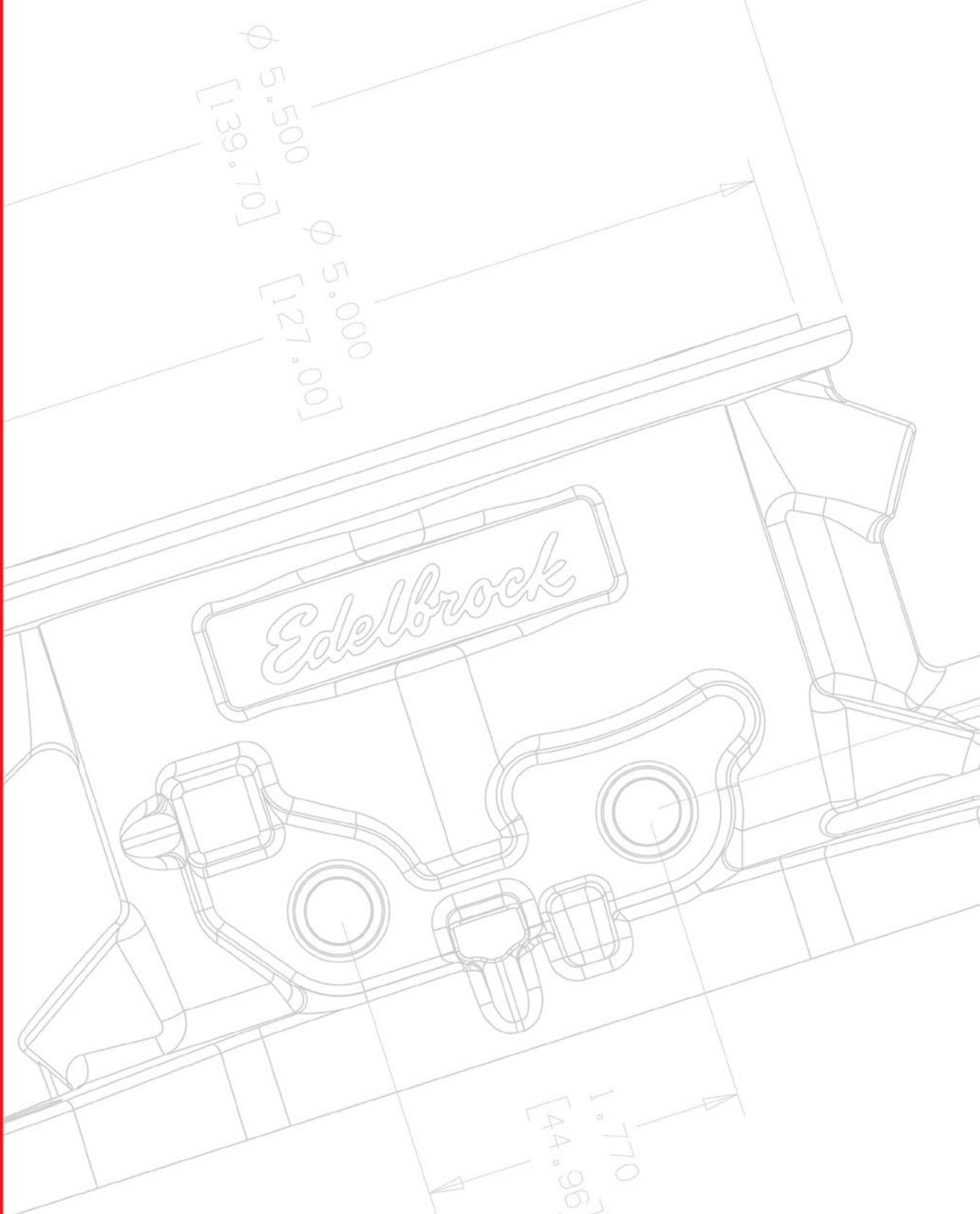

Edelbrock. LLC
2700 California St, Torrance, CA 90503
www.edelbrock.com