

# INSTALLATION INSTRUCTIONS

# **EGR** *ROLLTRAC*

## MANUAL

**Vehicle model:** RAM DT/1500 5.7Ft Bed LHD & RHD (New Body Style)  
 (Excludes models with RAMBOX® or other options / accessories  
 that would affect RollTrac fitment)  
**Year of Manufacture:** MY 2019 Onwards

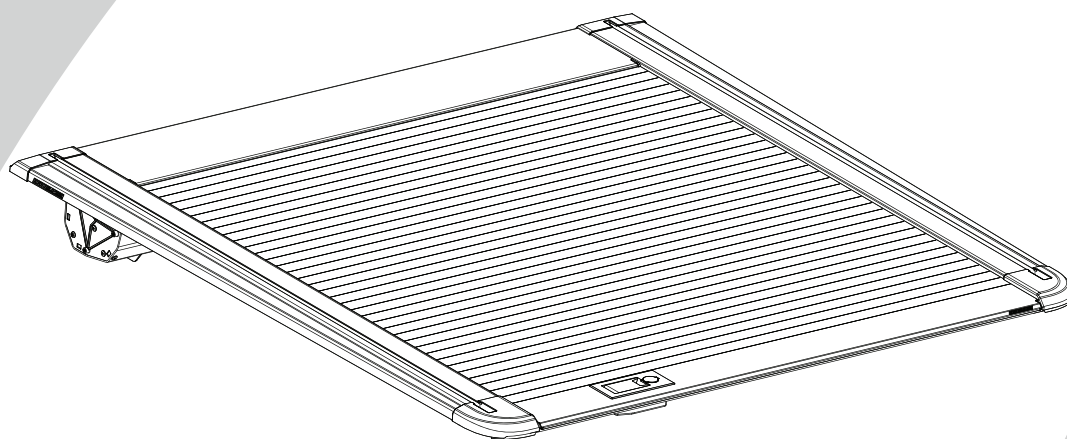

Installation time: 120 minutes

### Caution

- Do not attach EGR RollTrac in a location or by a method not specified.
- Do not use this product for any vehicle make or model, other than those specified in this document.
- Do not remove the plaque or label from this product.
- Do not modify the structure of the EGR RollTrac in any way.

### General Notes

- Read through the fitting instructions before installation of EGR RollTrac.
- Always install the accessory following the fitting instructions. Failure to do so may cause damage to the vehicle or the accessory.
- Ensure all recyclable discarded vehicle accessory components and packaging are recycled following local recycling regulations.
- It is always recommended that this accessory is fitted by a qualified Technician.
- Safely store and protect any removed vehicle components.
- Ensure all bare metal surfaces are protected using Automotive Bare Metal Primer and touch-up paint.
- Remove all metal swarf and dust from all vehicle surfaces if surface is used for accessory installation.

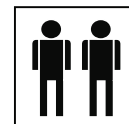

### Safety Notes

- Check that all work practices comply with safety standards.
- Please wear appropriate clothing and use safety equipment.



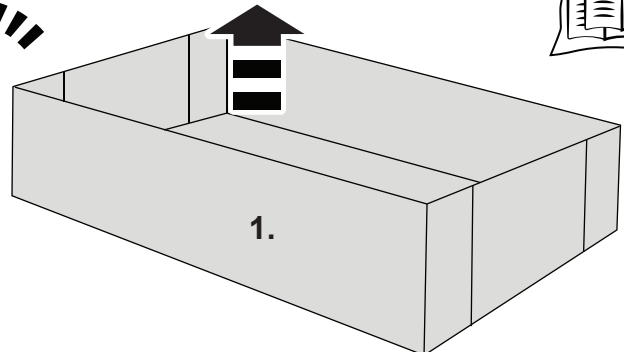
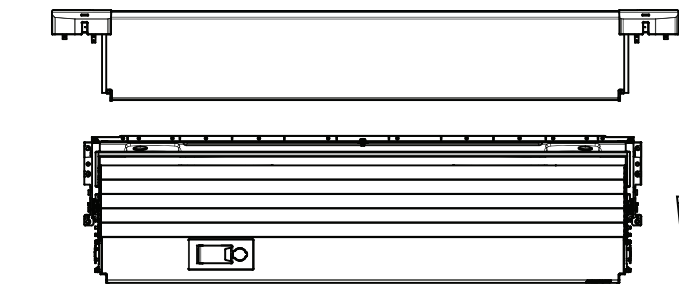
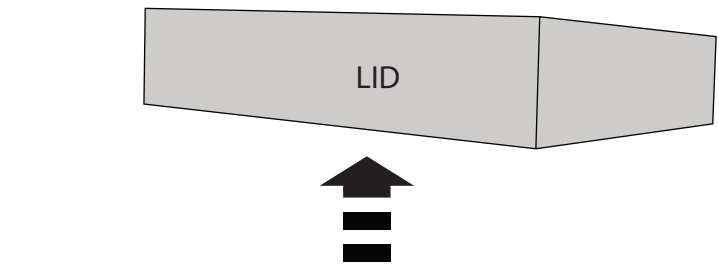
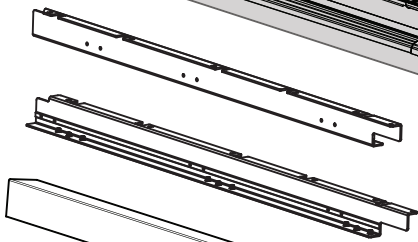
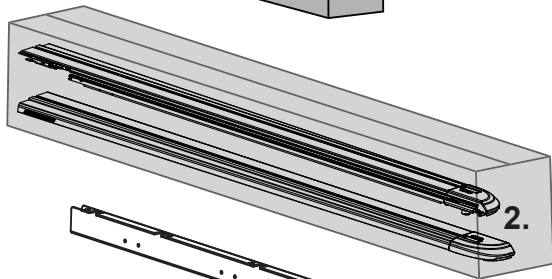
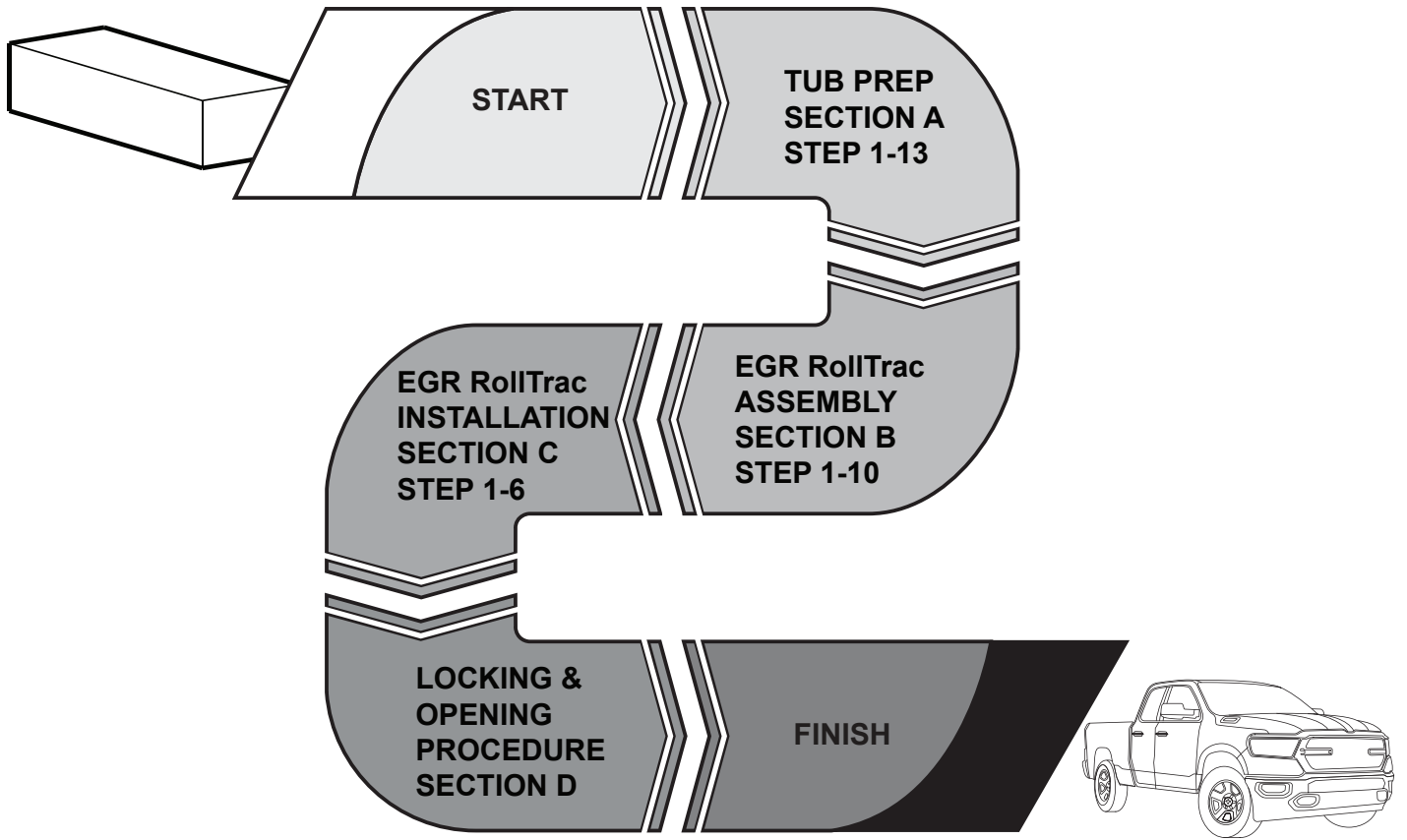

## KIT CONTENTS - COMPONENT NUMBER AND QUANTITY

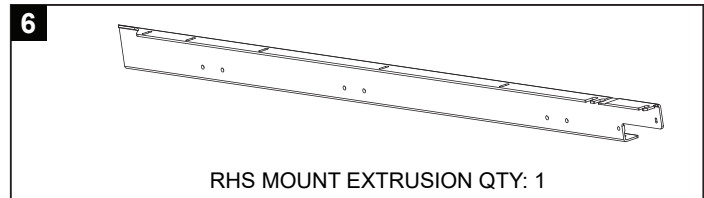
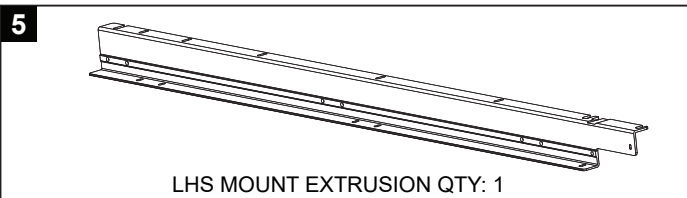
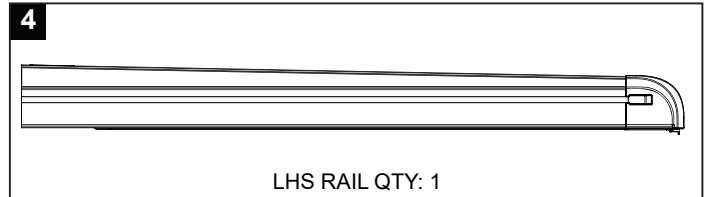
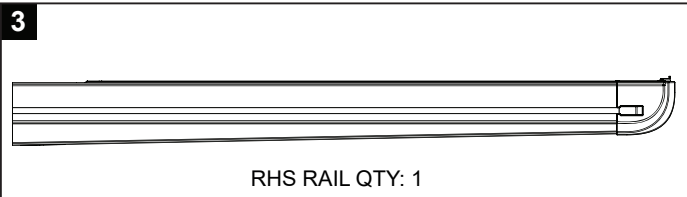
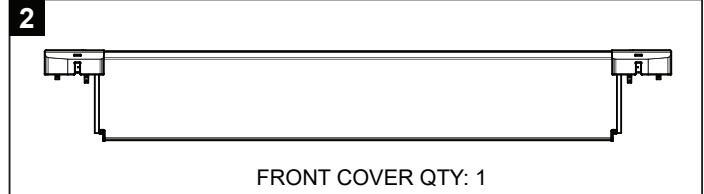
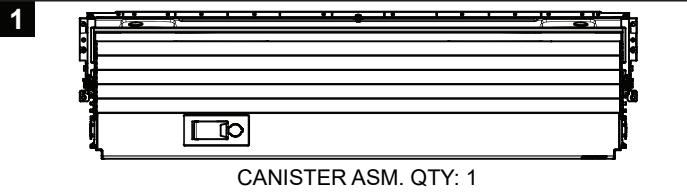

## EGR RollTrac M-Bar Assy Hardware Kit

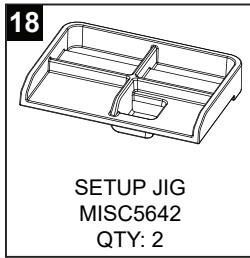
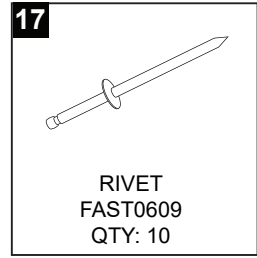
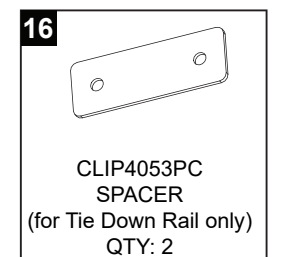
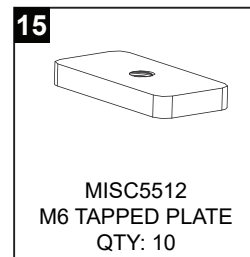
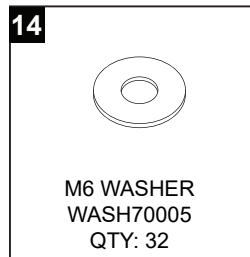
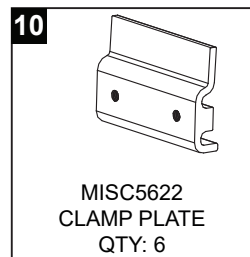
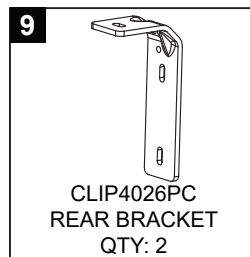
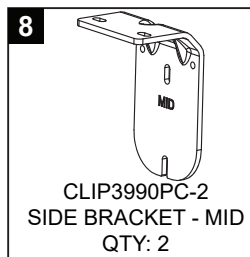
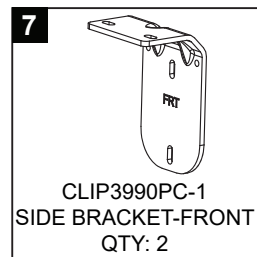

## EGR RollTrac FITTING KIT IN BOX

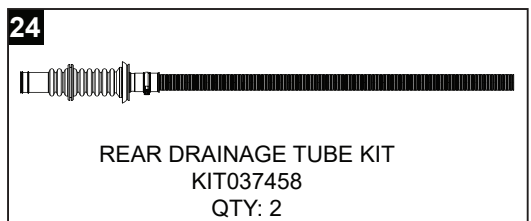
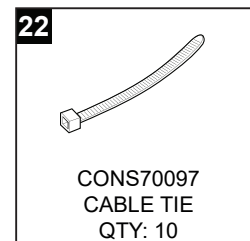
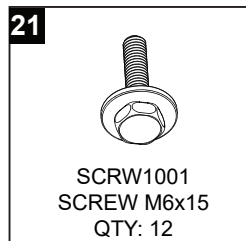

## EGR RollTrac FITTING KIT COMPONENTS IN BAGS

25

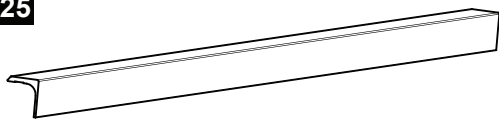

RUBBER EXTRUSION  
QTY: 1

## EGR RollTrac FITTING KIT ADDITIONAL ITEMS

26

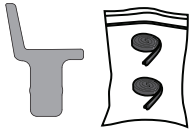

RUBBER  
EXTRUSION  
QTY: 2

INSTALLATION  
INSTRUCTIONS



OWNERS  
MANUAL



## TOOLS REQUIRED - NOT SUPPLIED IN KIT

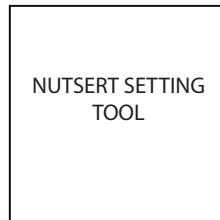
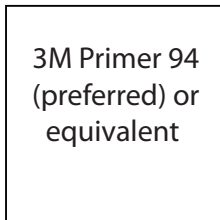
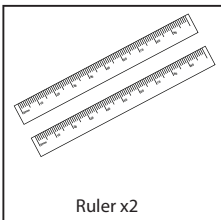
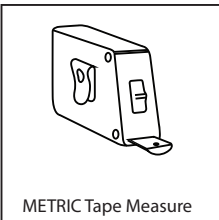
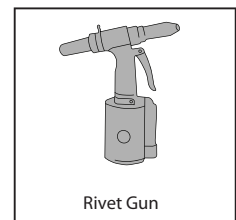
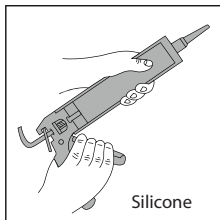
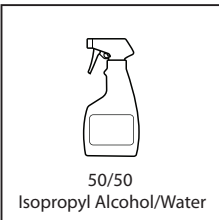
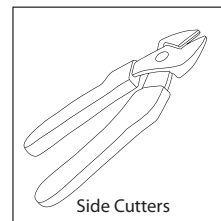
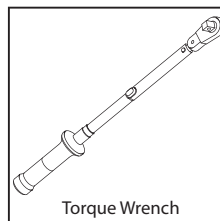
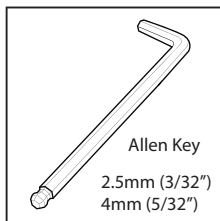
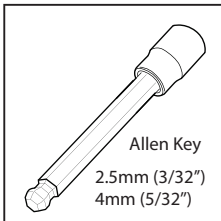
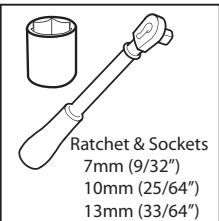
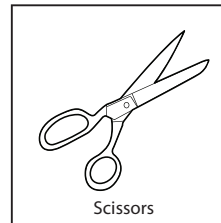
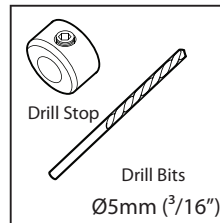
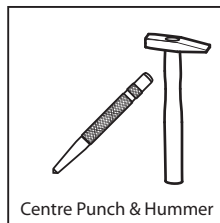
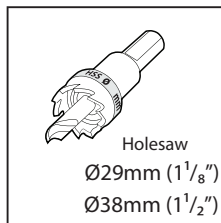
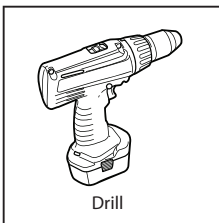

### GLOSSARY:

- 1 Number inside a square indicate part number
- 1 Number inside circle indicate the sequence within a step
- 1 Number inside the hexagon indicate torque instruction

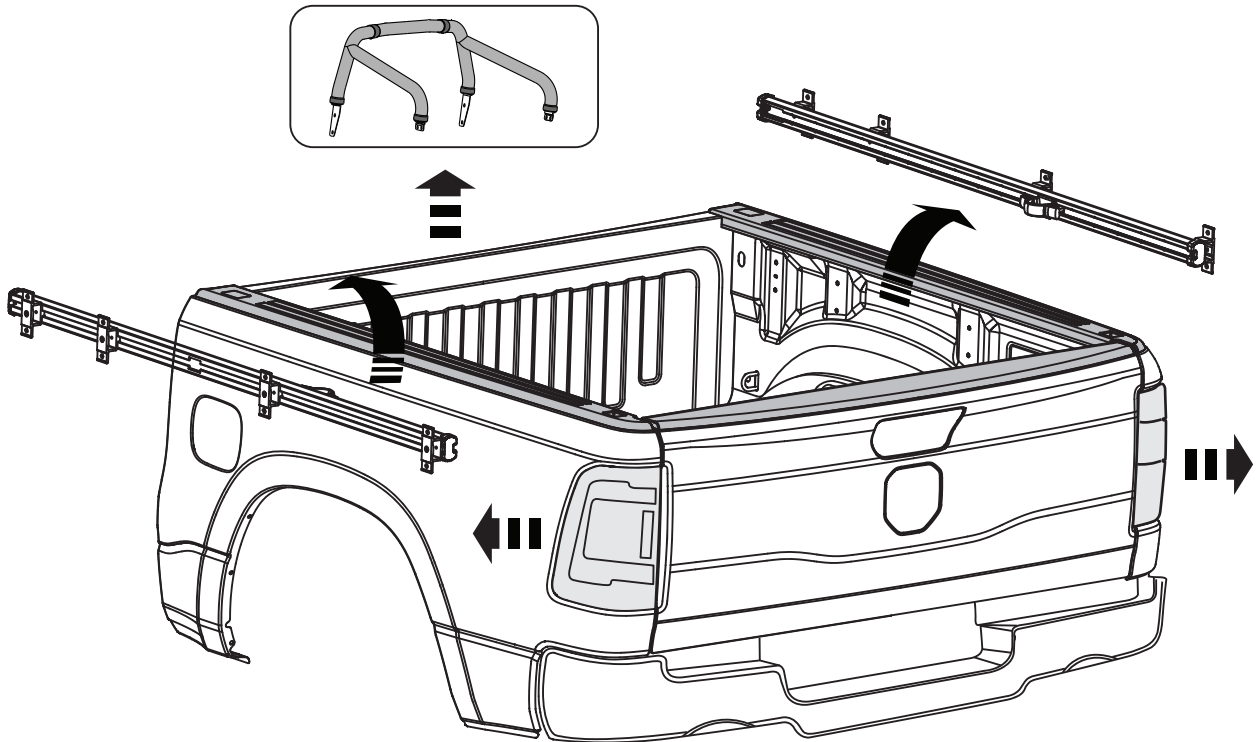

- 1 Carefully remove any accessories (Sports Bars, Utility Rails, etc.) attached to the bed of the vehicle. Thoroughly wash the vehicle bed and ensure that all dirt and grease is removed. Allow to dry. Clean the top surfaces of the bed and tailgate and allow to dry. Carefully remove both Rear Tail Lamps with the appropriate tools and store in safe place. Retain all hardware for re-installation. **IMPORTANT:** Remove and retain Tie Down Rails (if fitted), discard screws.

THIS SECTION LEFT INTENTIONALLY BLANK

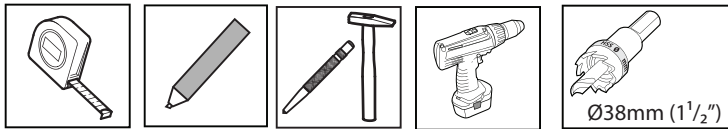

## HOLES FOR FRONT DRAIN TUBES RHS & LHS

### ATTENTION



Ensure that the diameter of the hole does not exceed  $\text{Ø}38\text{mm}$  ( $1\frac{1}{2}$ " ). Larger hole size will lead to water ingress into the bed

### INSTALL FRONT DRAIN TUBES TO BED

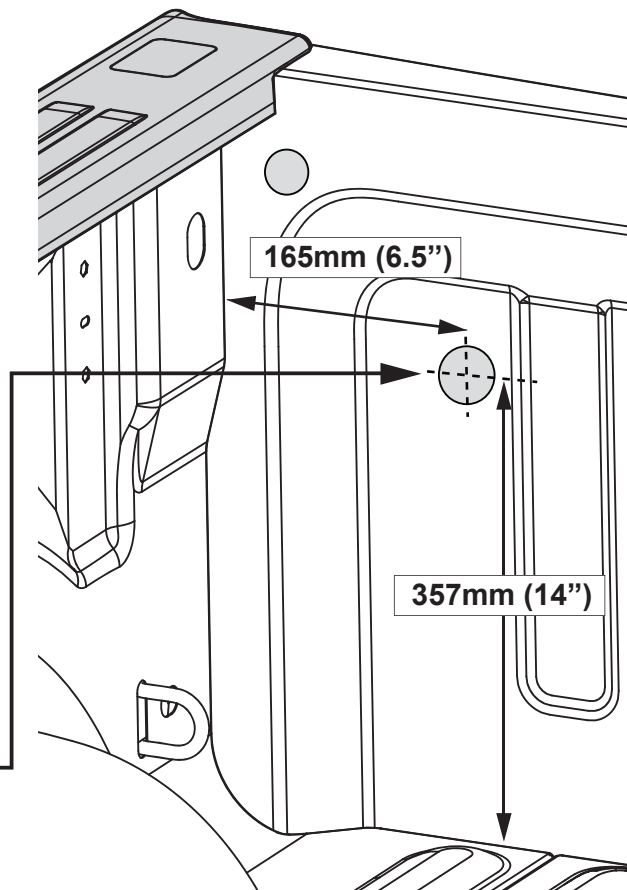
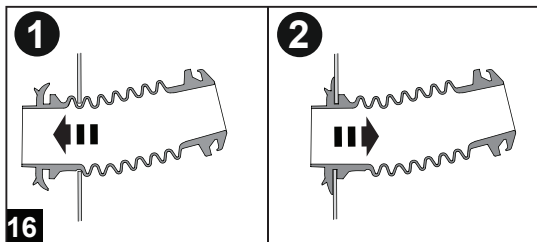

- 2** Mark the position of the front drain tube holes in the bed front panel and drill with  $\text{Ø}38\text{mm}$  ( $1\frac{1}{2}$ " ) holesaw. LHS shown, repeat on the RHS. Clean all burrs and coat the exposed metal with a suitable rust preventative (not supplied). Fit front drain tubes (16).

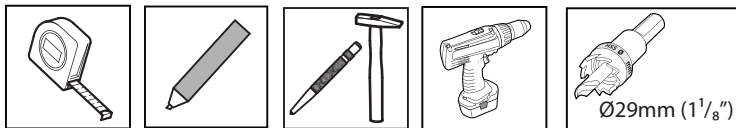

## HOLES FOR REAR DRAIN TUBES RHS & LHS

### ATTENTION



Ensure that the diameter of the hole does not exceed  $\text{Ø}29\text{mm}$  ( $1\frac{1}{8}$ " ). Larger hole size will lead to water ingress into the bed

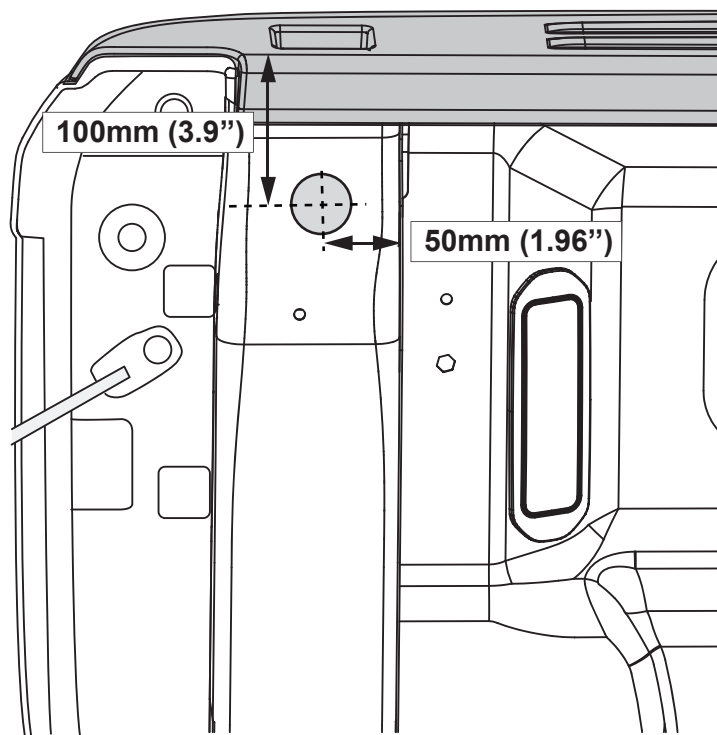

- 3** Mark the position of the rear drain tube holes in the bed rear panel and drill with  $\text{Ø}29\text{mm}$  ( $1\frac{1}{8}$ " ) holesaw. LHS shown, repeat on the RHS. Clean all burrs and coat the exposed metal with a suitable rust preventative (not supplied).

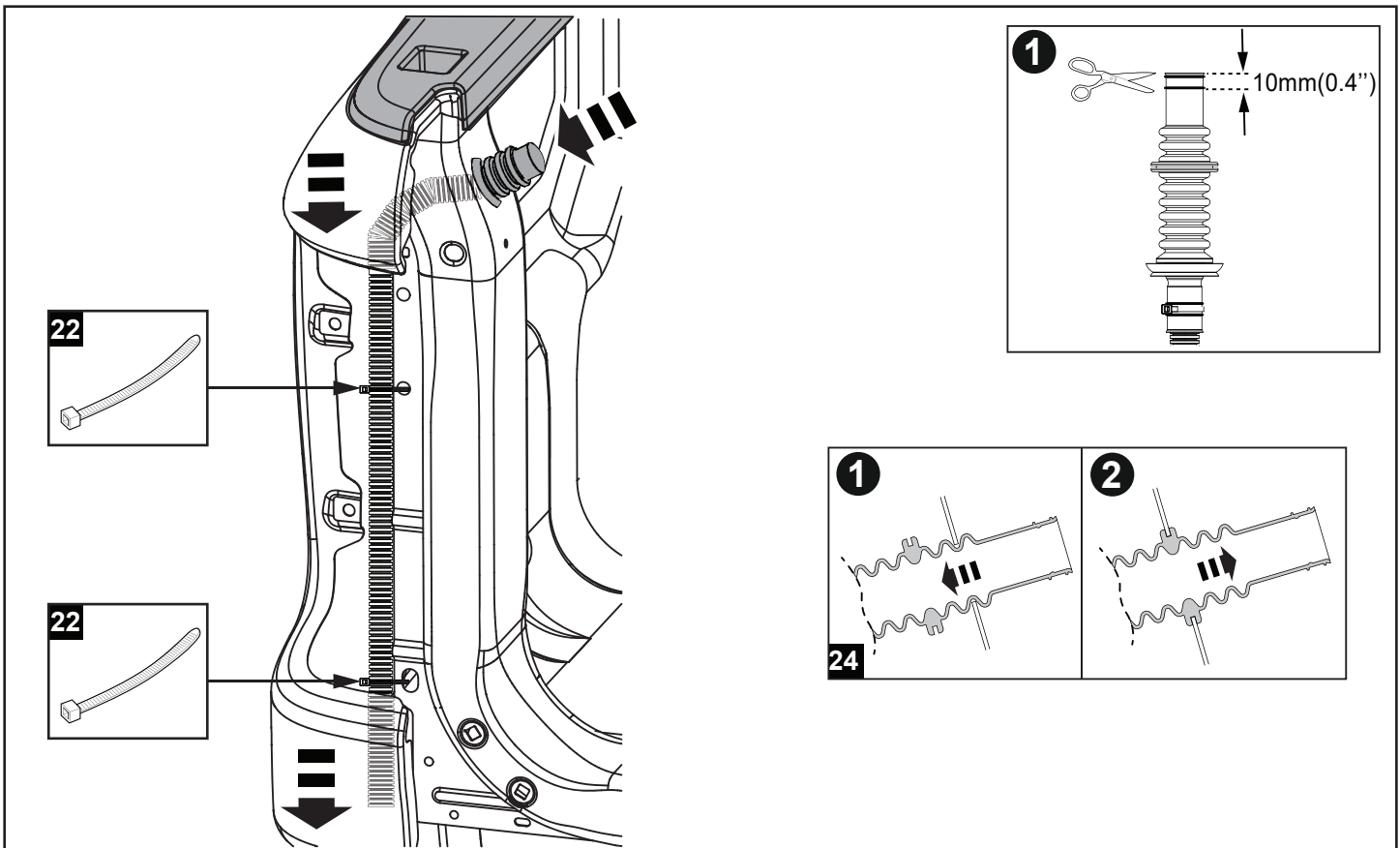

**4** Feed the rear drain tube into the drilled hole. Guide the plastic tube inside the tail light cavity towards the ground. Push the rubber tube in until it sits firmly in the hole. Secure the drain tube (24) to the sheet metal inside the tail light cavity using 2 cable ties (22). Refit Rear Tail Lamps.

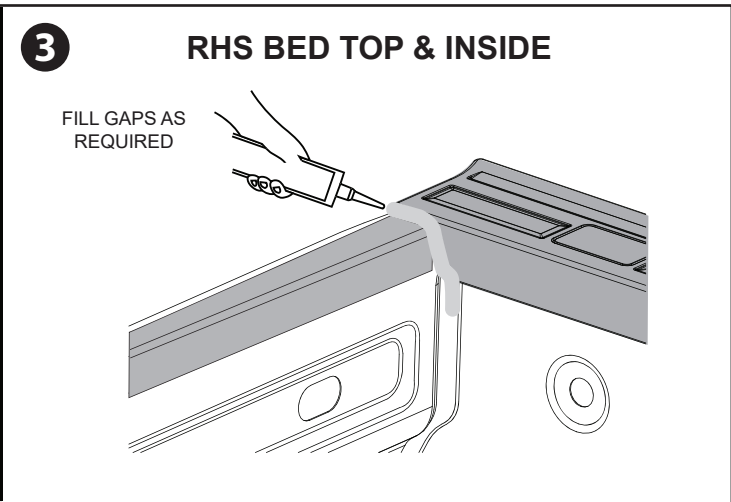
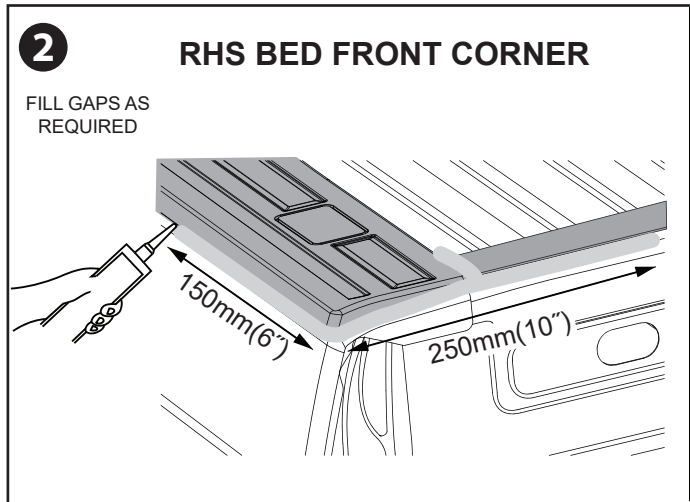
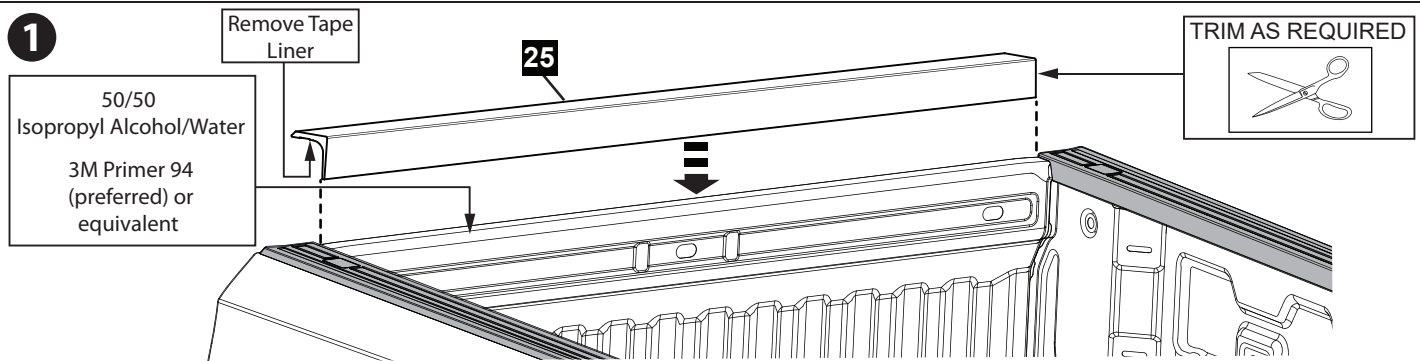

**5** Clean the front top of the bed using Isopropyl Alcohol/Water mix and apply primer to the top area. Allow to dry. Place the extrusion (25) on front of the vehicle bed, check the length and trim to full width if required. Pre-peel 50mm (2") of the tape liner from one end of the Rubber Extrusion (25). Place the Rubber Extrusion on top of the bed as shown and centralise. Once in position, peel the liner and apply firm pressure from the top. Silicone the gap between the panels as shown on both sides. NOTE: Holes in the bed should be sealed with Silicone to prevent dust and water ingress as required.

NUTSERT SETTING  
TOOL

11 x6

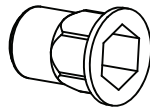

RHS

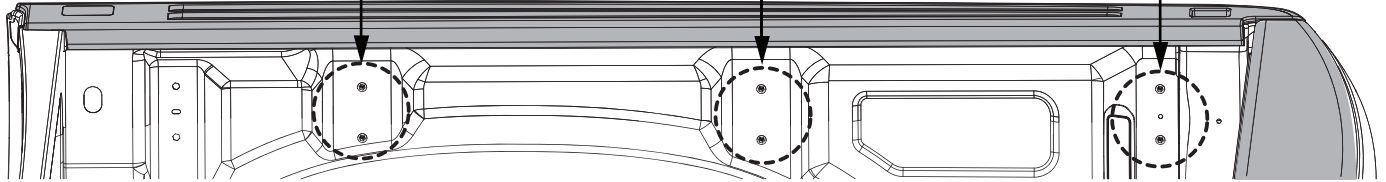

- 6 Check the six location in the bed side wall for M6 nutserts (11). If not fitted previously, fit 6 on each side (provided) using suitable Nutsert setting tool.

RHS

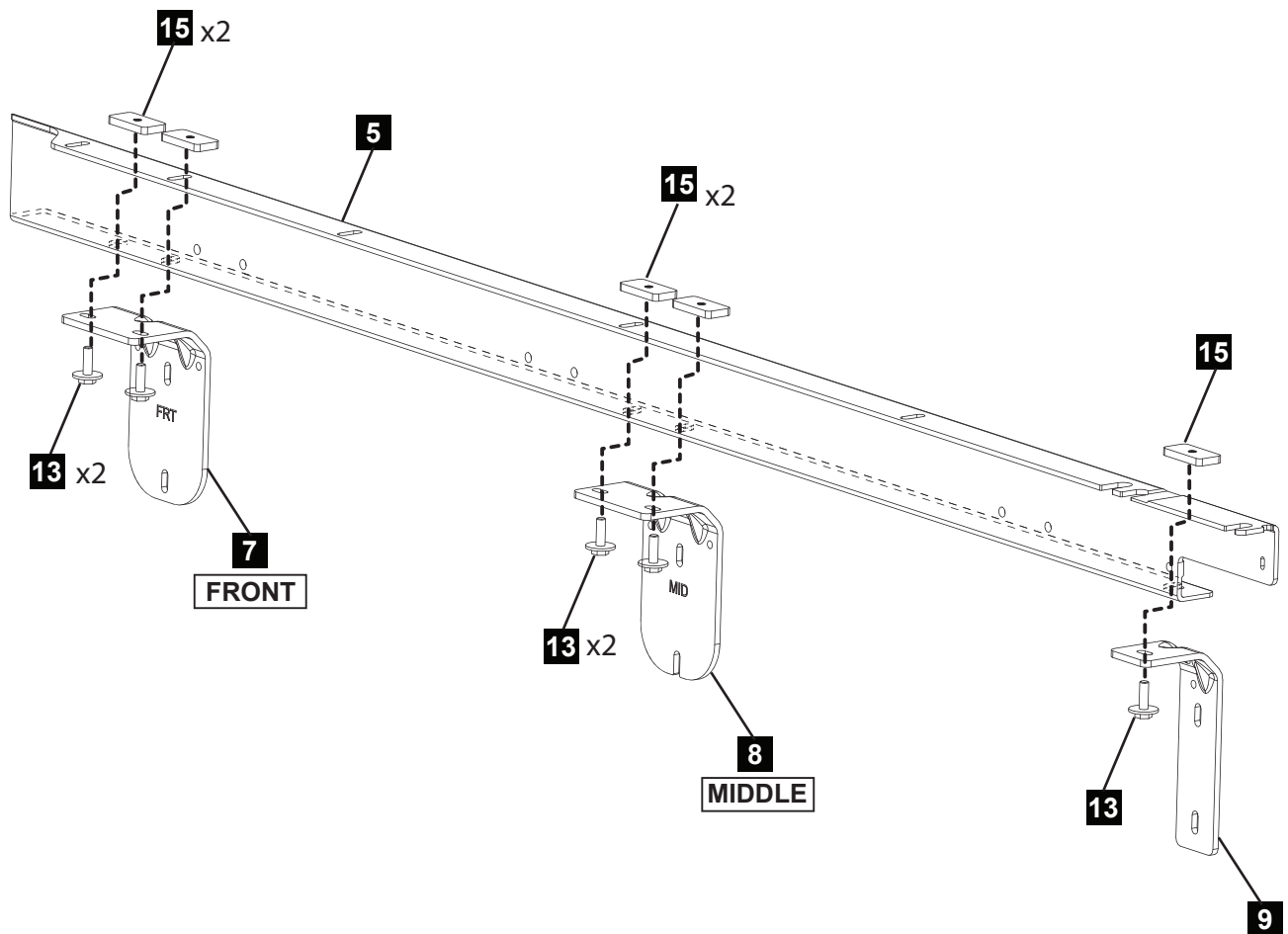

- 7 Fit the side brackets to the RHS mount extrusion as shown. Do not torque the screws at this stage.  
**IMPORTANT:** Side Brackets have markings: FRT (front) and MID (middle).



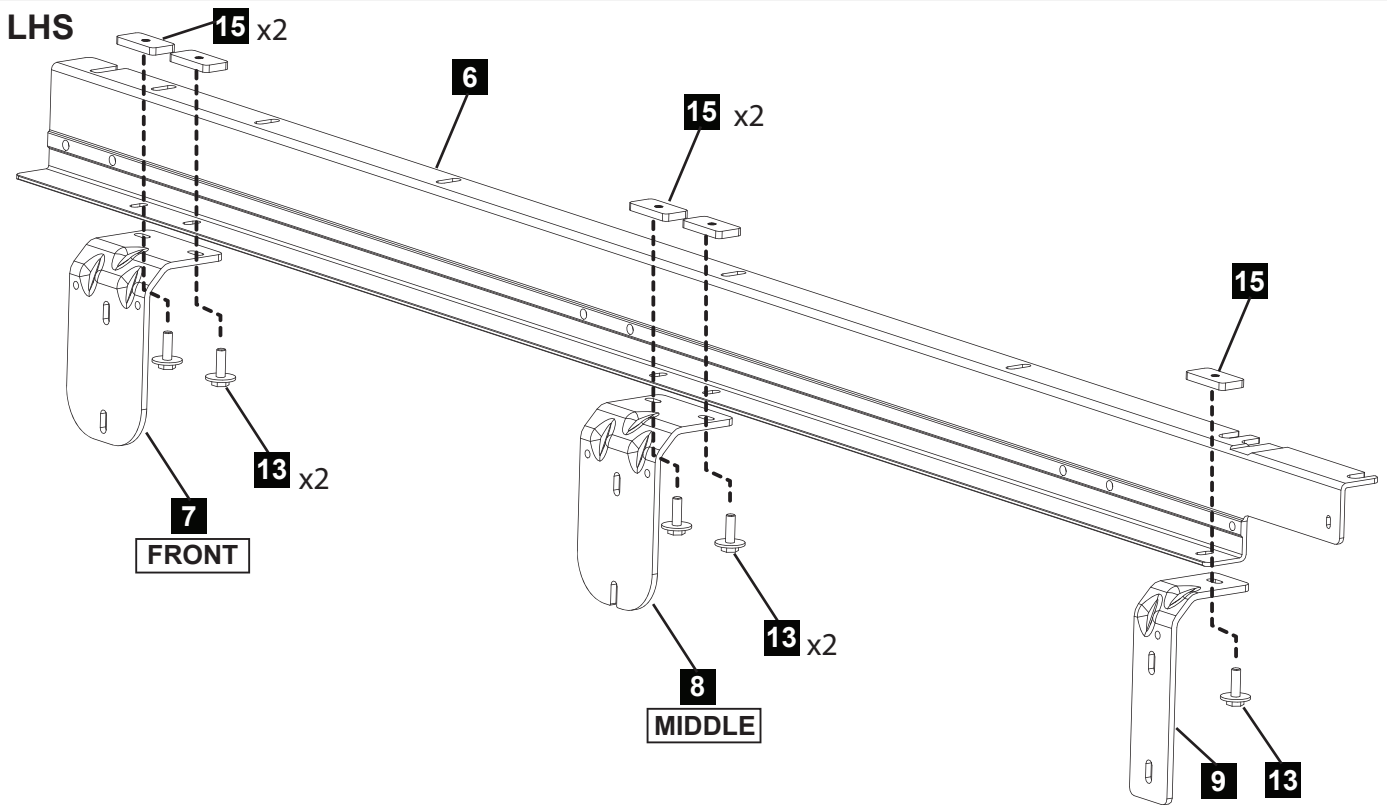

**8** Fit the side brackets to the LHS mount extrusion as shown. **NOTE:** Do not torque the screws at this stage. **IMPORTANT:** Side Brackets have markings: FRT (front) and MID (middle).

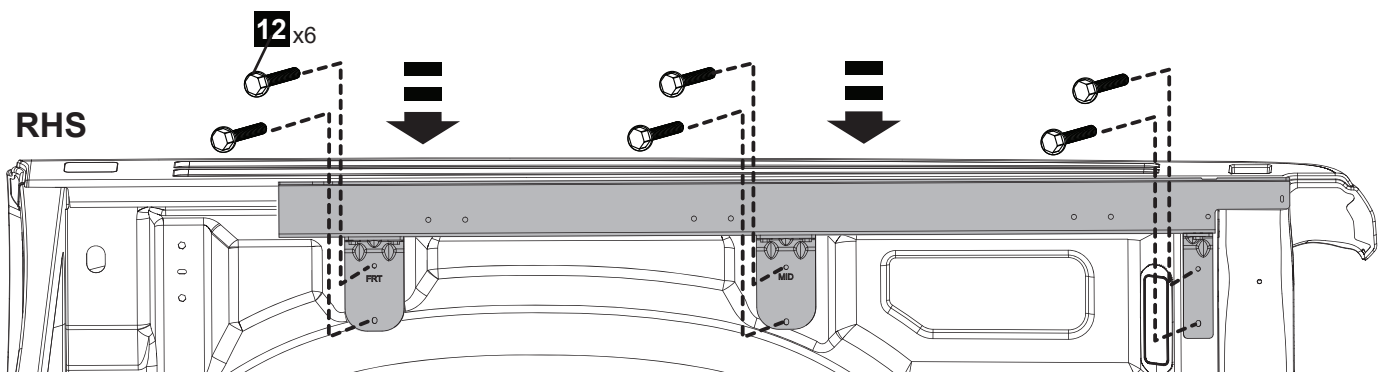
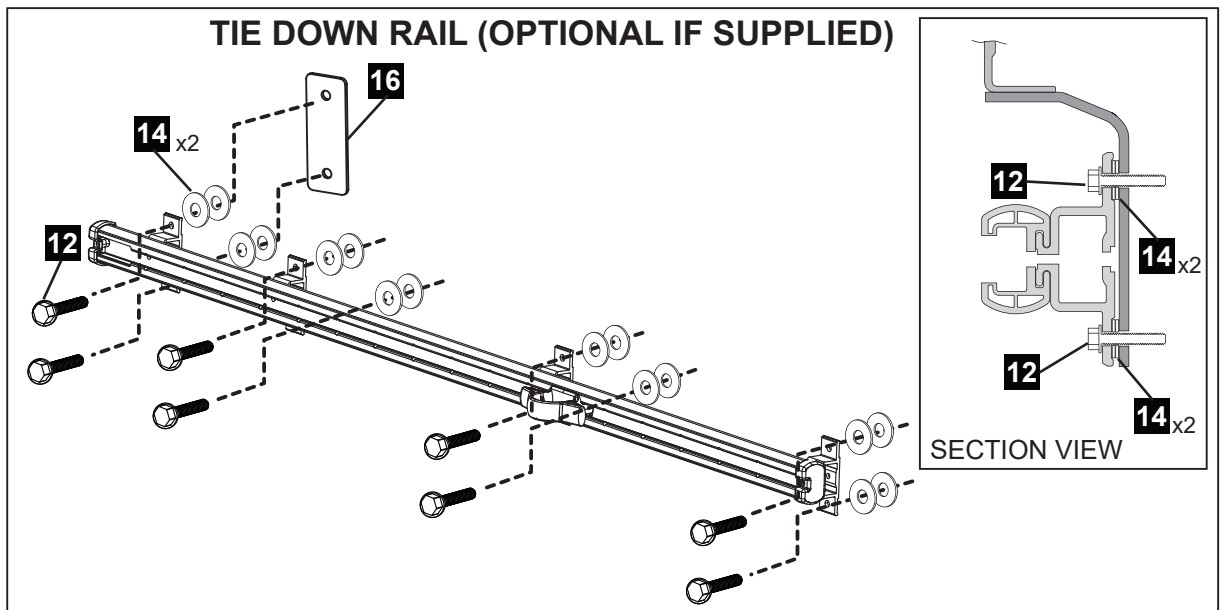
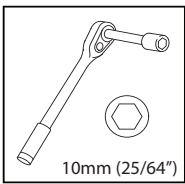

**9** Fit the mount extrusion to the inside of the bed. Secure loosely to the nutserts with M6 screws (12). **NOTE:** Fit the Tie Down Rail at the same time if supplied and use the spacer (16) at the front location as shown, and two washers (14) per screw between Tie Down Rail and mounting bar support brackets. Repeat for LHS.

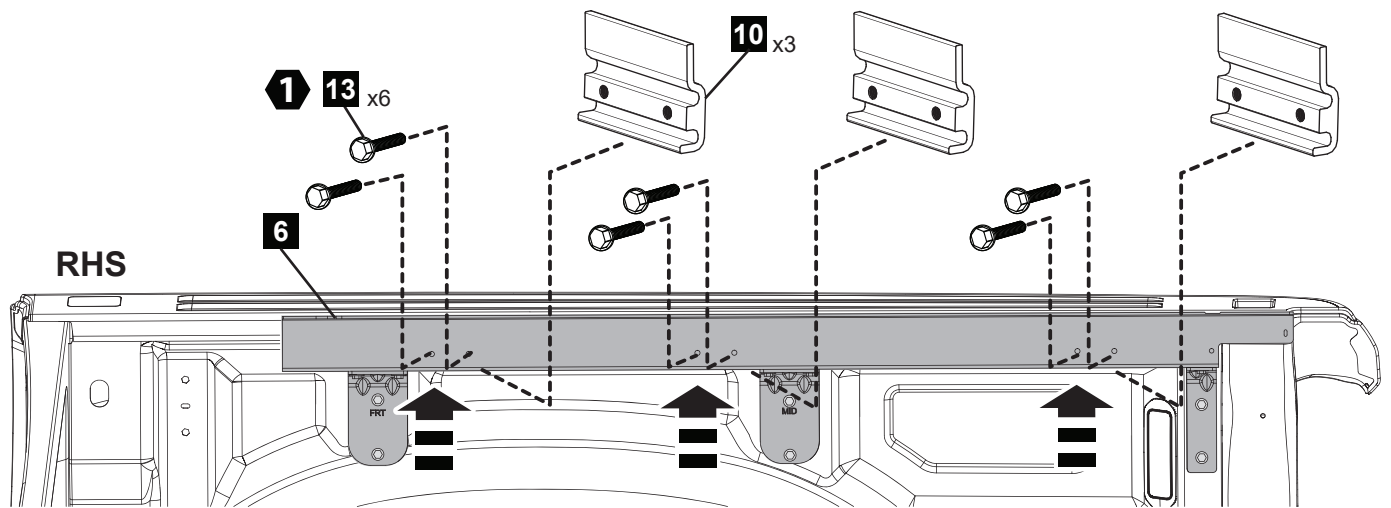
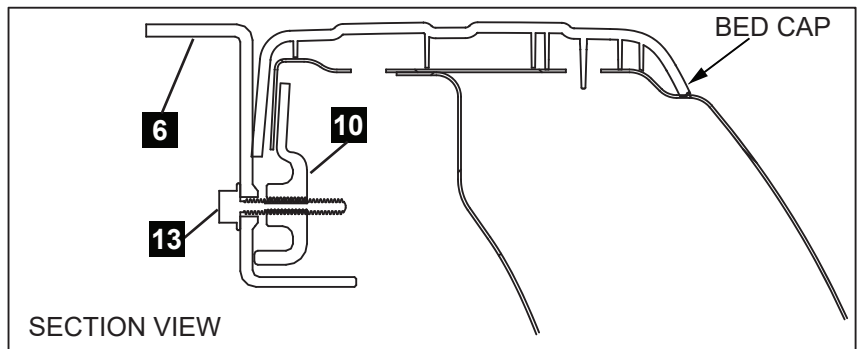
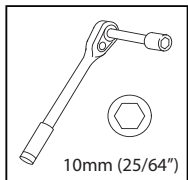

**10** Fit the clamp plates (10) inside the bed as shown in the detail and loosely secure with screws (13). Repeat for LHS.

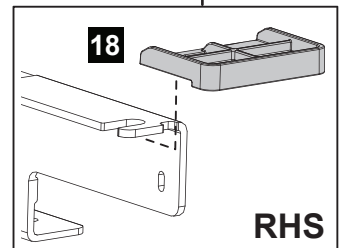
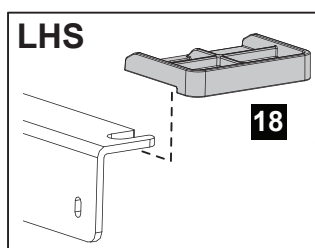
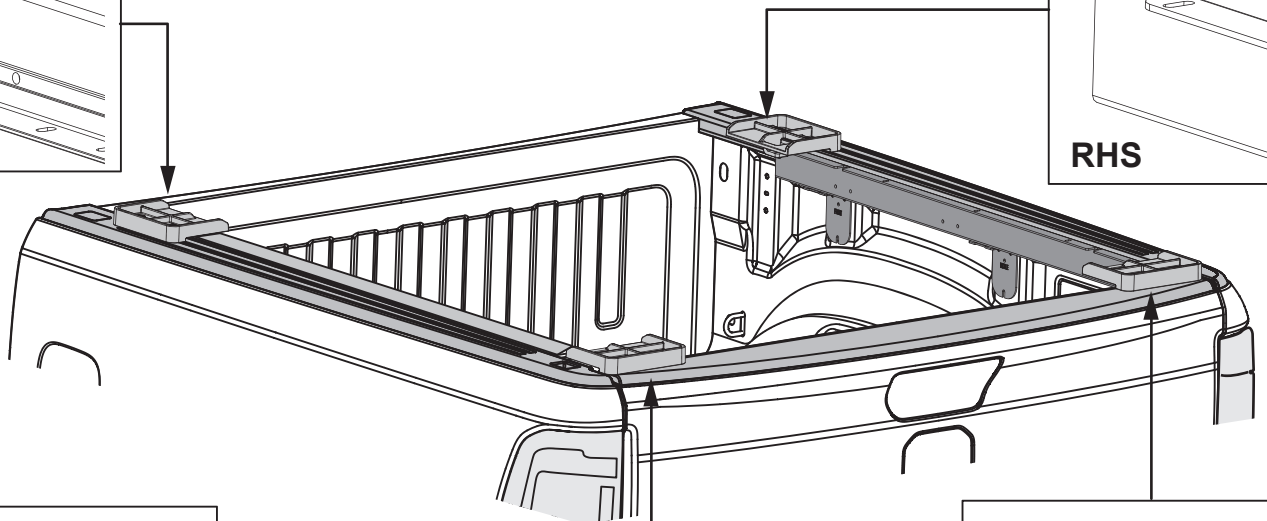
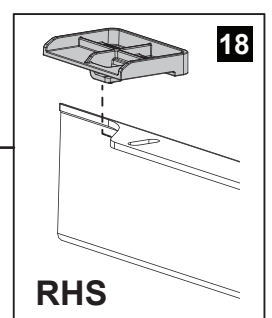
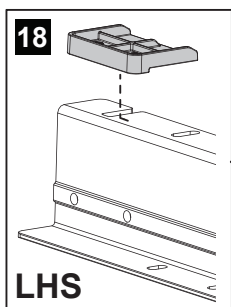

**11** Fit the setup jigs to set up the RH mount extrusion first. Adjust the mount extrusion front position to the bed cap and rear position to the top of the tailgate using the setup jigs as a guide. Details as follows.

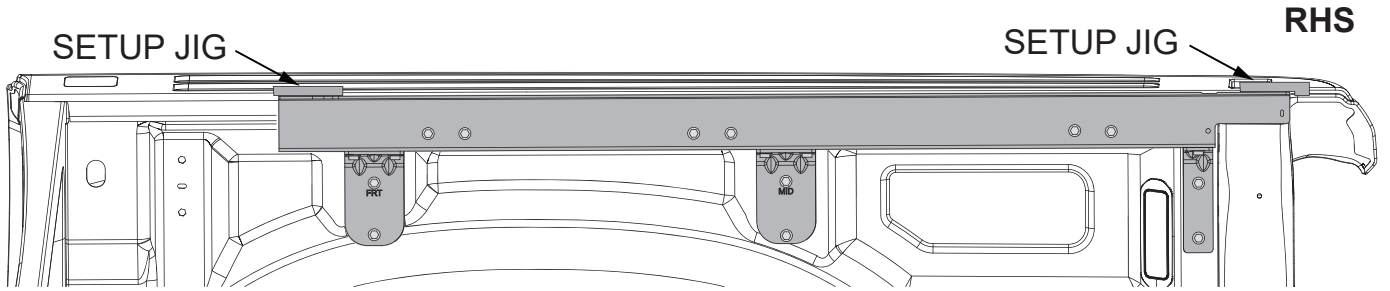
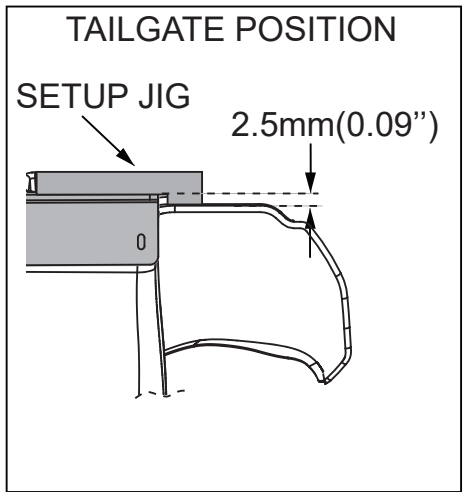
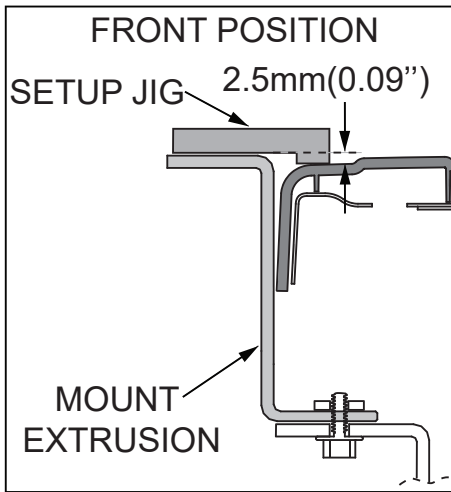
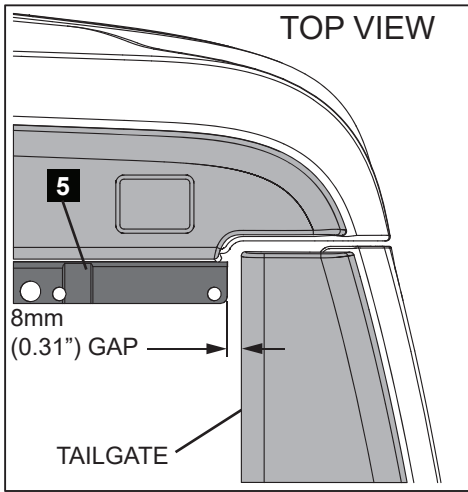

**12** Set front/back position of the mount extrusion relative to the tailgate (8mm (0.31") gap) as shown in top view. Set the vertical position of mounting extrusion by adjusting the extrusion relative to the bedcap (ensuring parts are held level). Use the setup jigs to achieve a 2.5mm(0.09") step between the front end of the extrusion Vs bedcap; and a 2.5mm(0.09") step between the rear end of extrusion Vs tailgate - as shown in detail views above.

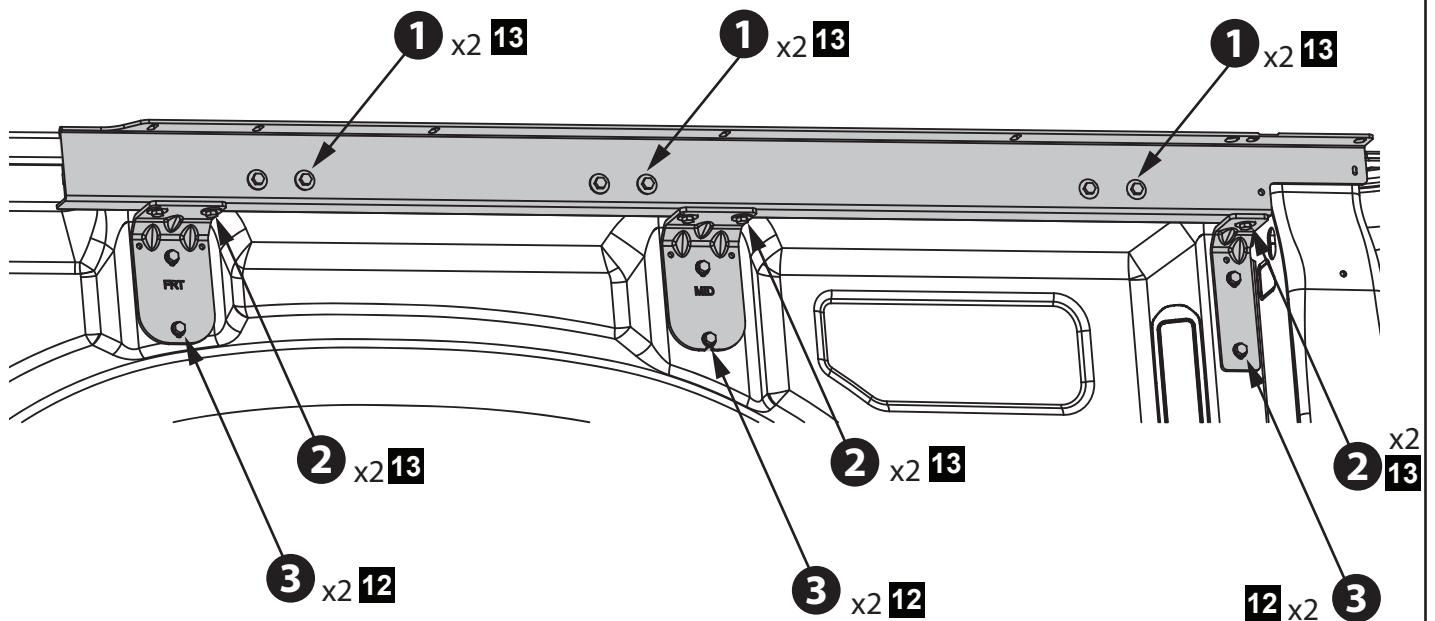
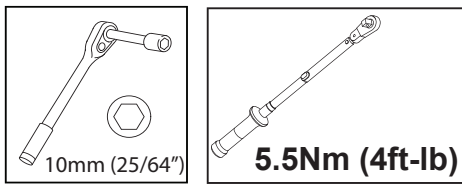

**13** Torque all screws 12 & 13 to 5.5Nm(4ft-lb) in order shown above. Recheck mounting extrusion position from step 12 and remove setup jigs. Repeat step 12-13 for LHS.



DURING ASSEMBLY PROCEDURE SUPPORT AT CENTER OF CANISTER ONLY, PLACE ON TOP AND BASE CARTON (OR SIMILAR), COVER WITH FOAM BLANKET. TO AVOID SCRATCHING POWDERCOATED SURFACES.

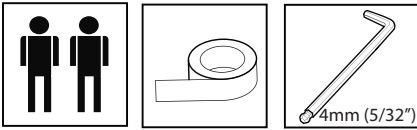

**FIT RHS FIRST**

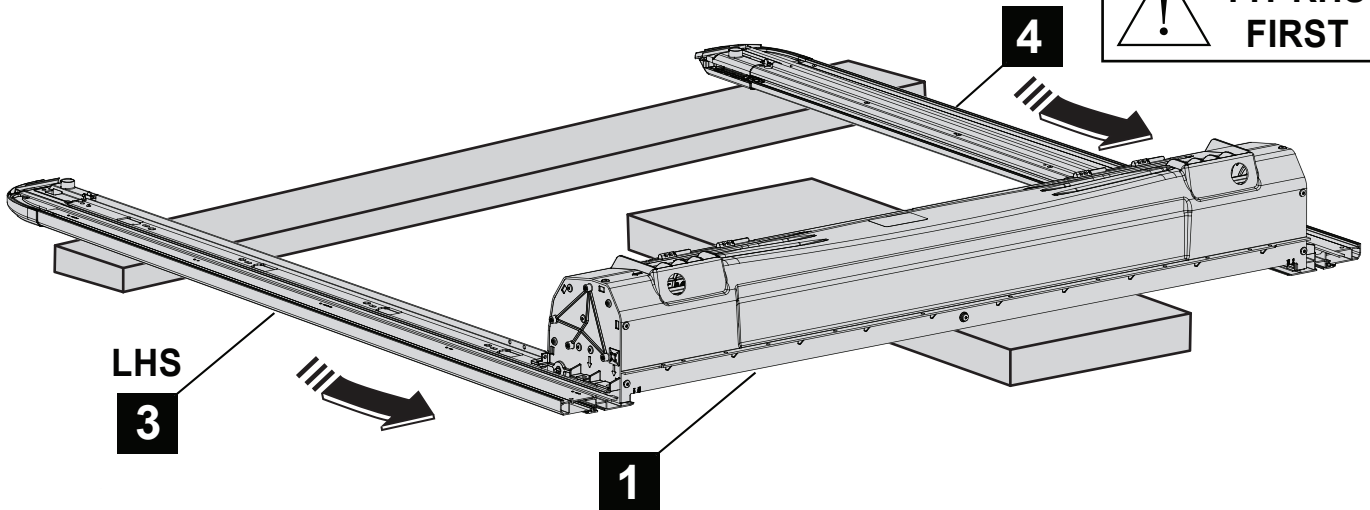

**1** **ATTENTION: SEAL MUST FACE IN THE DIRECTION AS SHOWN. WARRANTY VOID IF ASSEMBLED INCORRECTLY.**

HOLD SEAL FLAT  
USE CLOTH TAPE

**RHS SHOWN**

**APPROX 300mm (12")**

**2** **ATTENTION: EXPOSE 3 SLATS PRIOR TO FITTING SIDE RAILS.**

**ENSURE ENDS ARE ALIGNED**

**ATTENTION: WIPE THE SEAL AND SIDE RAIL WITH WAX & GREASE REMOVAL TO ENSURE THE CLOTH TAPE WILL ADHERE TO THE SIDE RAIL AND SEAL**

**1** Place the canister (1) on two protected boxes as shown, ensure hand rail and slat ends are aligned. Tape up the seal on the Side Rail (3) as shown.  
**IMPORTANT:** Carefully align and slide the rail over the handrail endcap and canister endplate taking particular care to ensure that the siderails are slid straight and no undue force is applied. Details in following steps.



DURING ASSEMBLY PROCEDURE SUPPORT AT CENTER OF CANISTER ONLY.  
PLACE ON TOP AND BASE CARTON (OR SIMILAR), COVER WITH FOAM BLANKET TO  
AVOID SCRATCHING POWDERCOATED SURFACES.



**1**

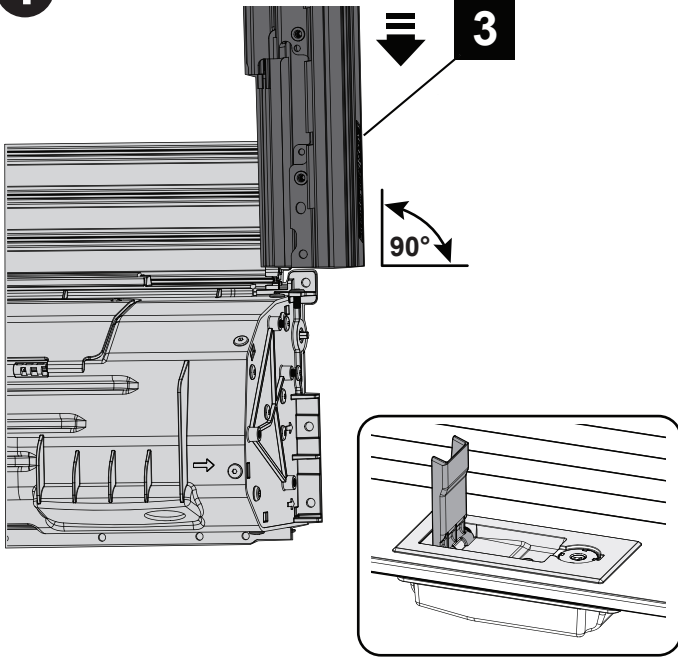

**2**

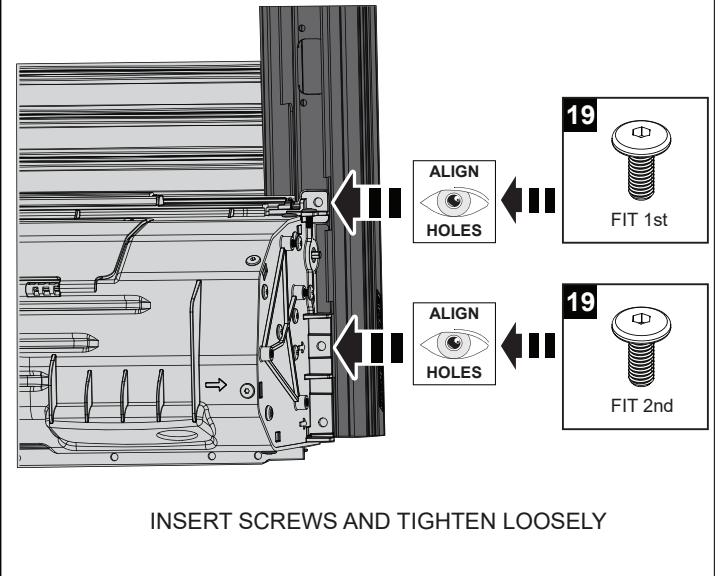

**2** Pull hand rail to expose 3 slats. Fully open handle to retract brake pads. Slide the Rail over slat ends and onto endcap location pins. Align the holes and secure loosely with two screws (19). Do not tighten. Repeat for LHS Rail (4).

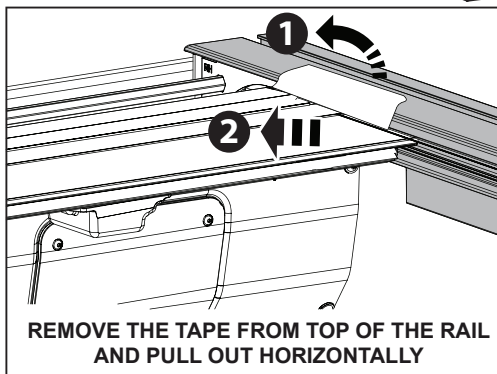
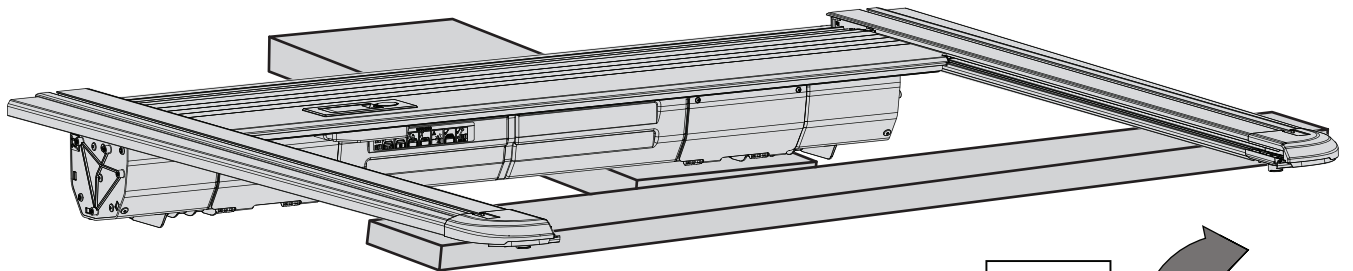

**!** ATTENTION: SEAL MUST FACE IN THE DIRECTION AS SHOWN. WARRANTY VOID IF ASSEMBLED INCORRECTLY.

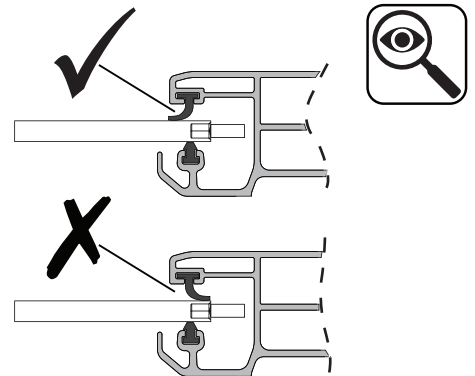

CHECK SEAL IS IN POSITION AND NOT DAMAGED

**3** Carefully turn the assembly over and place onto a protected surface. Remove the tape holding the rubber seal and check the seal position as shown. Repeat for LHS Rail.

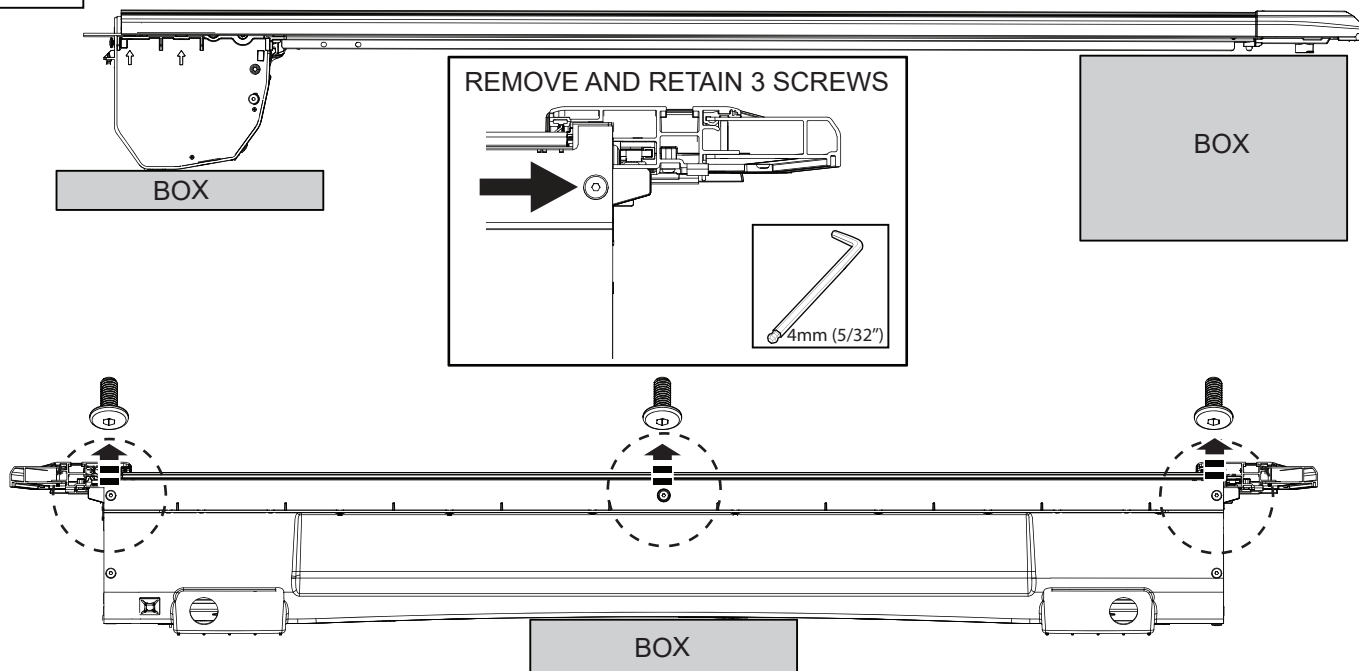

- 4** Remove the 3 pre-fitted screws from the rear of the cover which will be used to secure the Front Cover (2) to the assembly. Ensure the product is not scratched or damaged when laying flat.

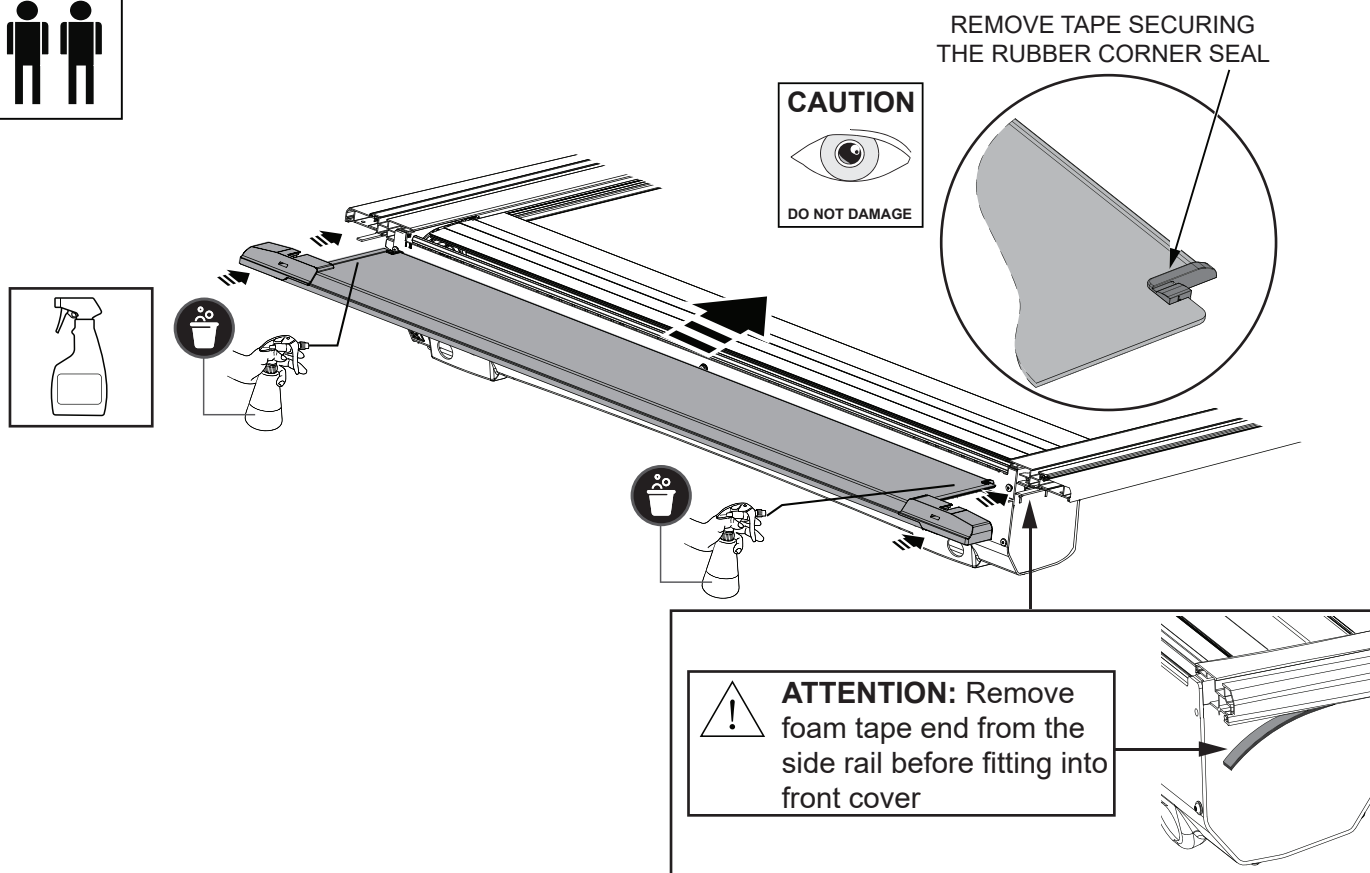

- 5** Slide the Front Plate (2) over the canister and into the side rail channels ensuring that the foam side rail tape is pulled out of side rail and the small rubber corner seal on the RHS and LHS of the front plate are not damaged. **IMPORTANT:** Spray the front cover edge with soapy water to allow it to slide easily into the sides, twisting side rails outwards will also help.

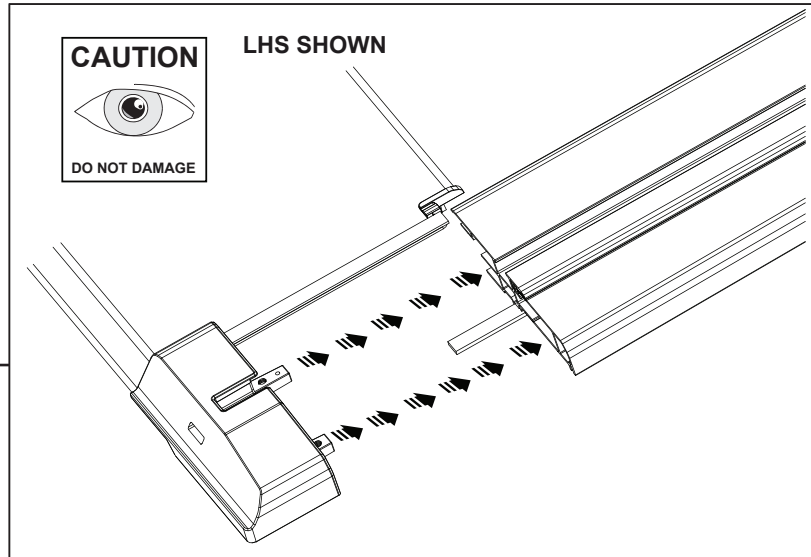
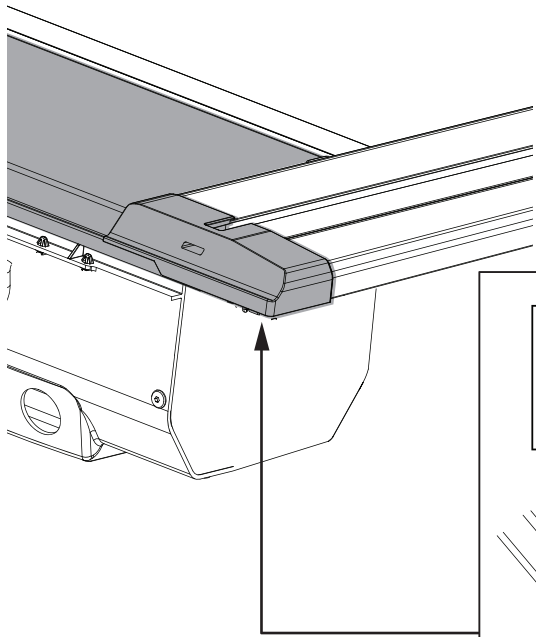

**6** While sliding the front cover ensure the cast connectors are align.

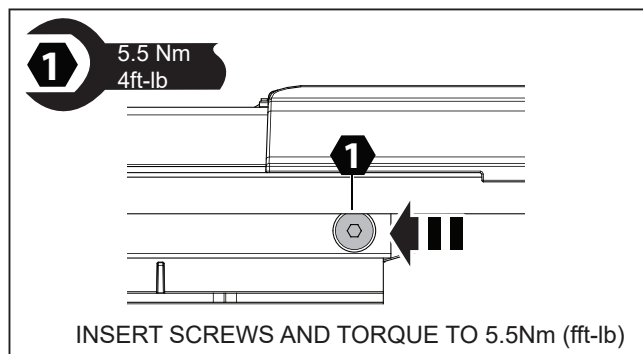
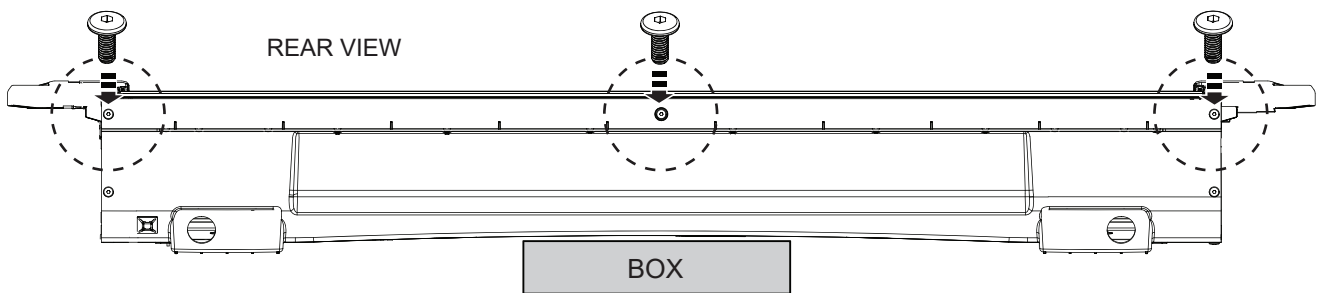
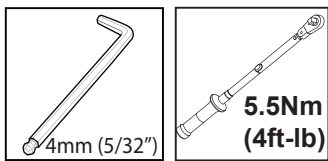

**7** Using the 3 screws removed from Step 4, secure the Front Plate (2) to the Canister Assembly (1) and torque to 5.5Nm (4ft-lb).

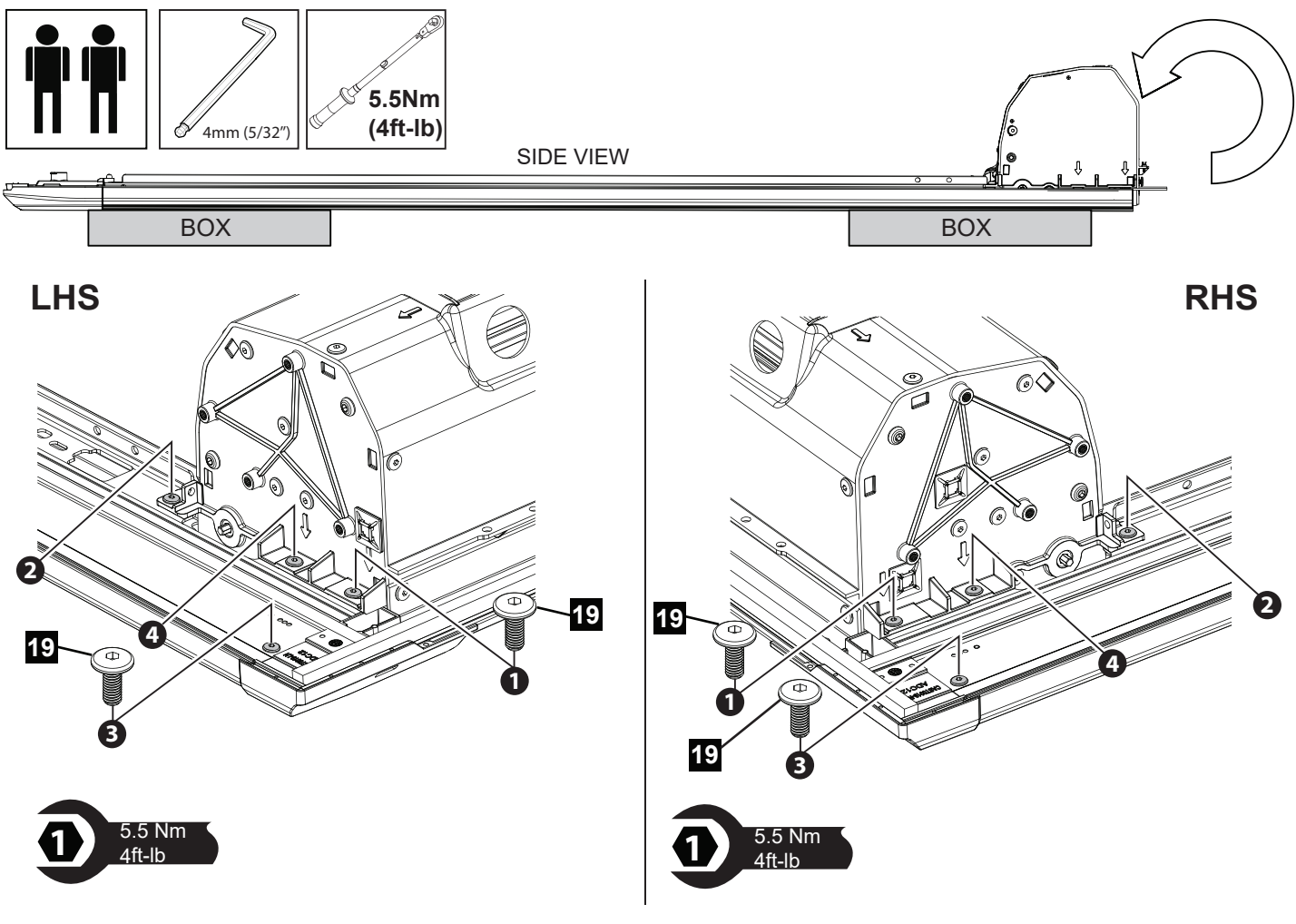

**8** Carefully flip the assembly over onto a flat protected surface which will not damage the cover or scratch the paint work. Install the 2 screws (19) on each side through the canister and side rail into front cover. Torque all screws in order shown to 5.5Nm (4ft-lb).

**LHS SHOWN - RHS IS A MIRROR IMAGE**

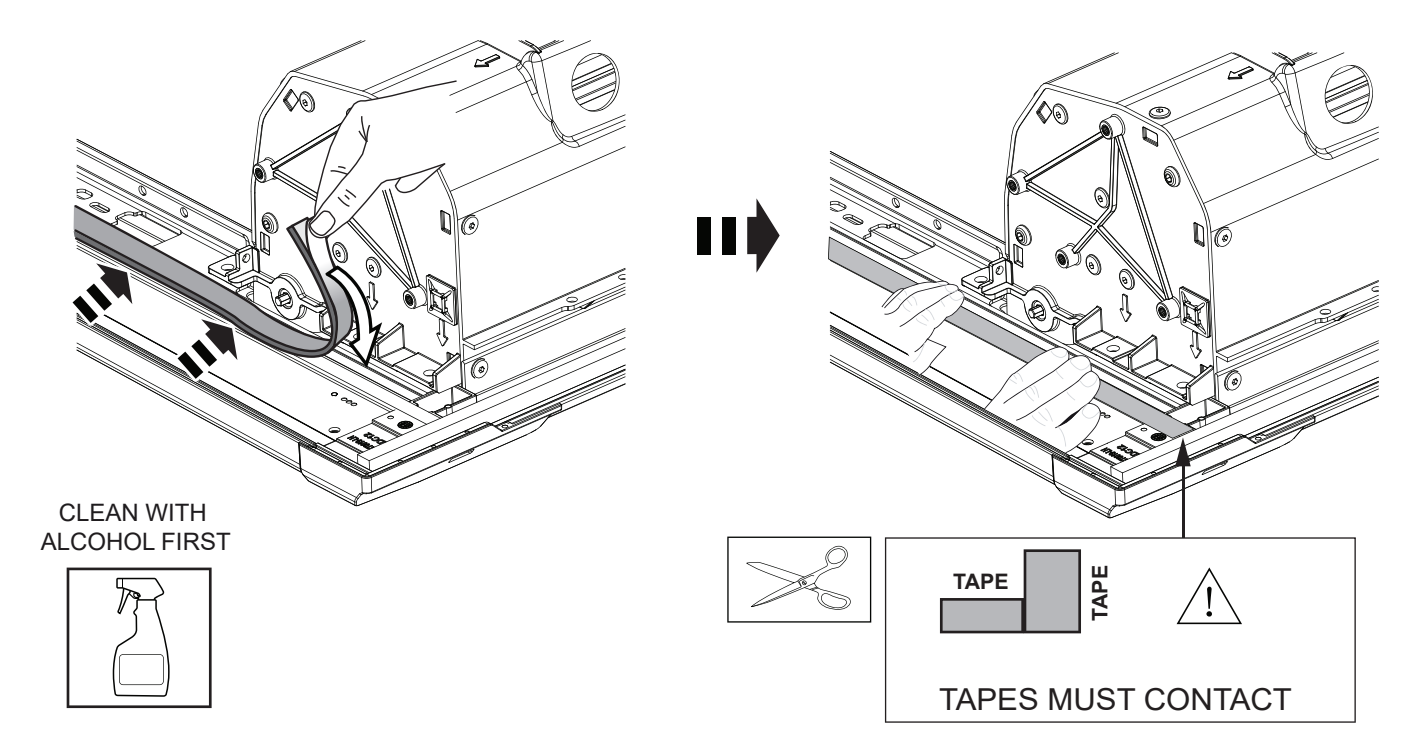

**9** Clean powder coated surface first with alcohol spray. Trim foam tape length to ensure the end will butt against front cover seal - avoiding any gap. Peel the protective liner from the foam tape, adhere to the channel in the side rail, Press down firmly to secure. Repeat on RH side rail.



INSTALL RUBBER SEAL  
IN SIDE RAILS

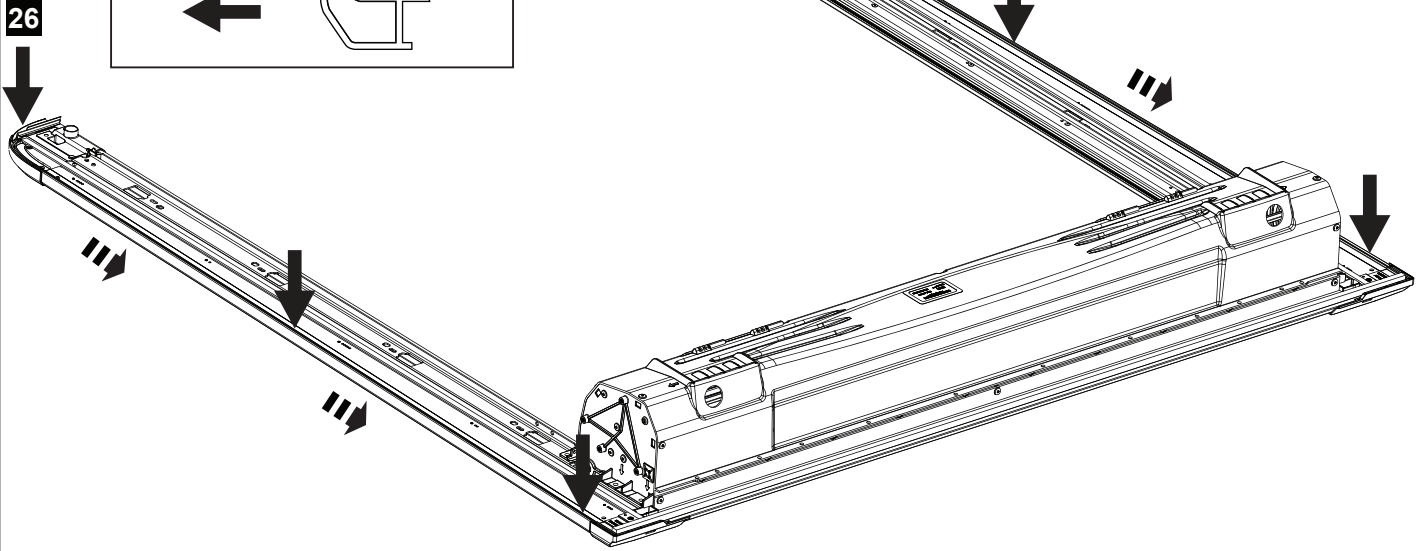
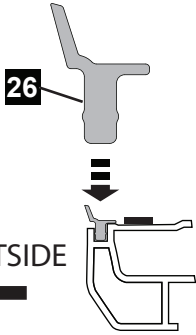

- 10** Install the Rubber Perimeter Seal (26) into each side rail and ensure seal is firmly seated (note the seal orientation).  
**Important:** do not stretch the seal while fitting.

THIS SECTION LEFT INTENTIONALLY BLANK

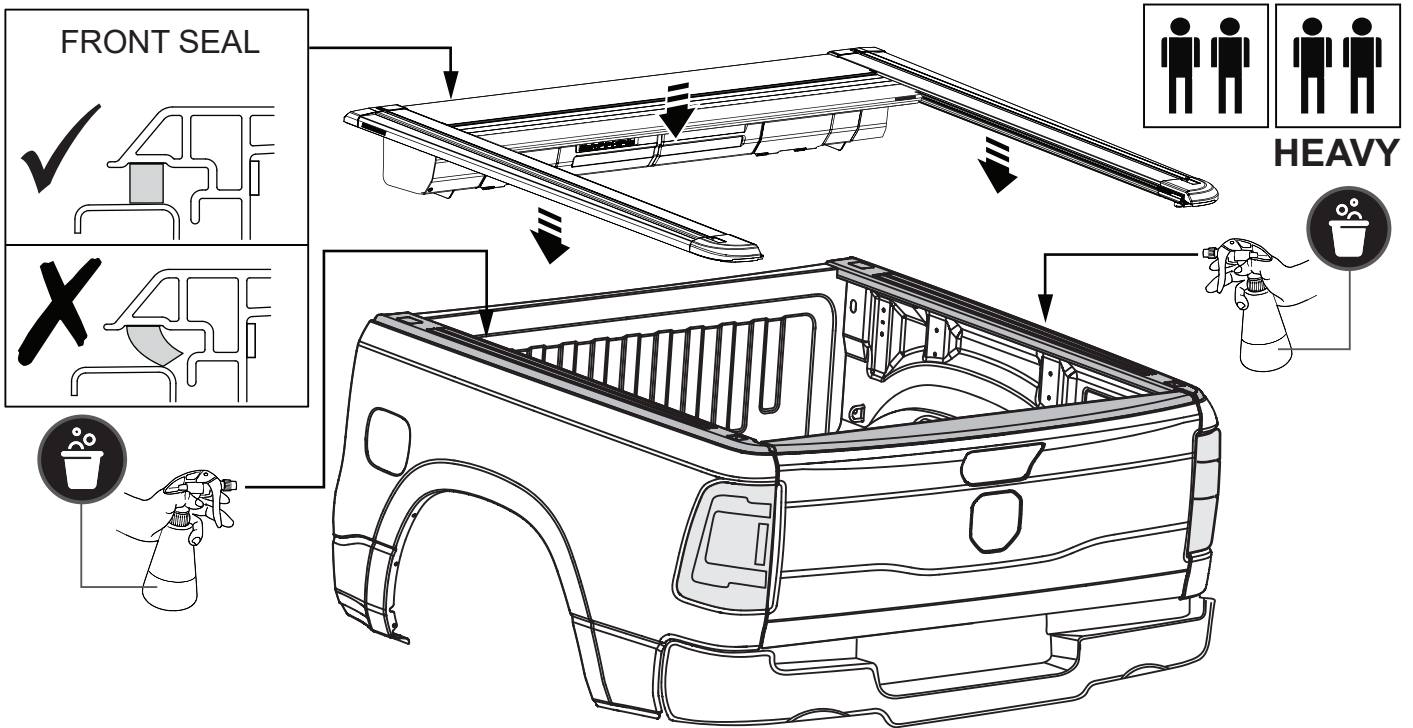

- 1 Spray the top surface of the vehicle bed liberally with a soapy water solution to enable the Cover to slide easily. Using two people to lift the cover from both sides and carefully lower it onto the bed. Ensure all seals are sitting vertically as illustrated, by lifting the cover and dropping vertically into position.

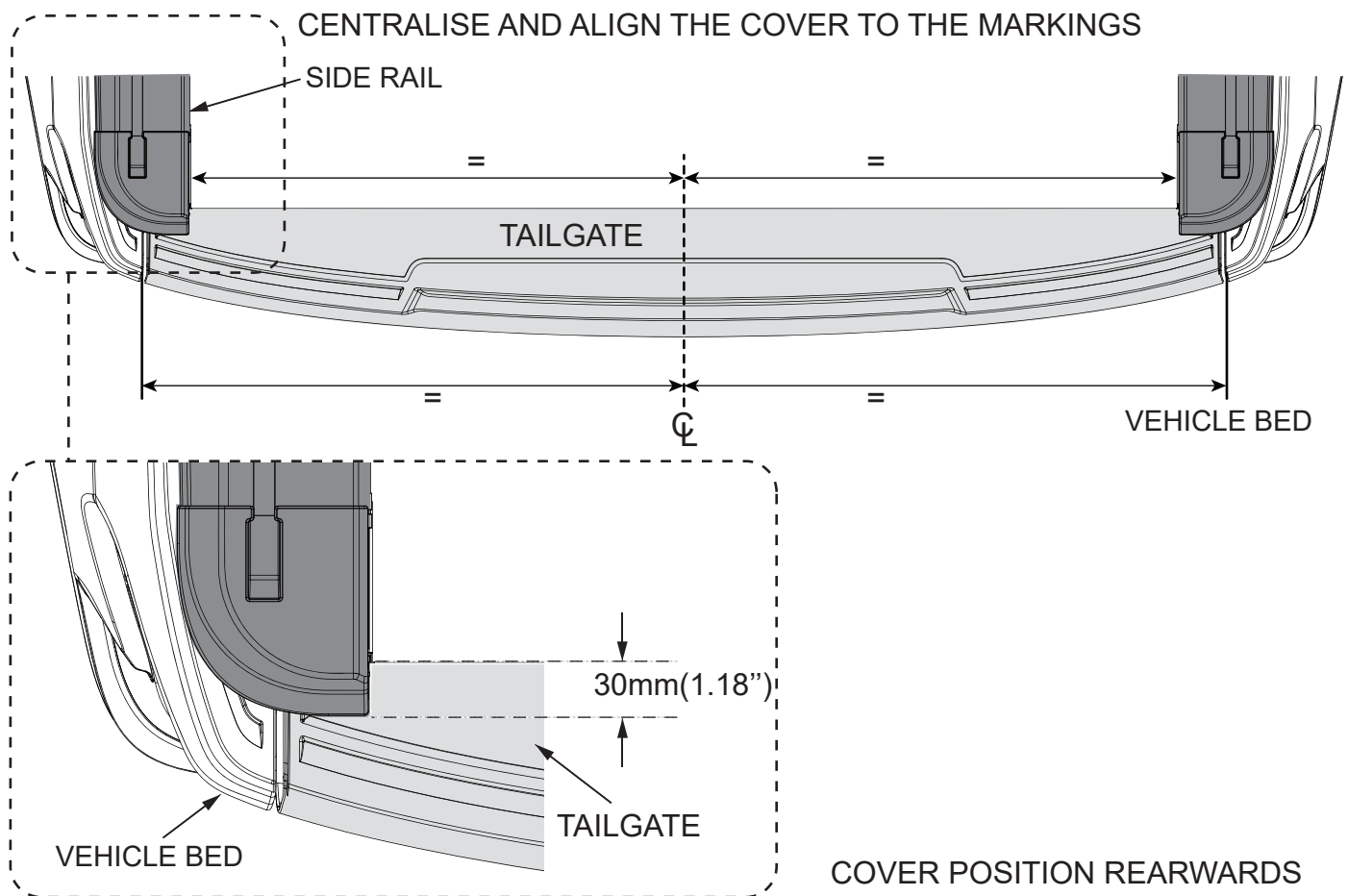

- 2 Adjust the front/back position of the cover so that it is 30mm(1.18") rearward of the tailgate inner edge as shown. Apply masking tape at the centre of the tailgate. Measure the distance between the rear corners of the vehicle bed and draw a centre line on the masking tape. Measure the distance from the marked centre line to both rear corners of the RollTrac and ensure the side rails are parallel and equally distanced. Ensure seals are not deformed when repositioning cover.

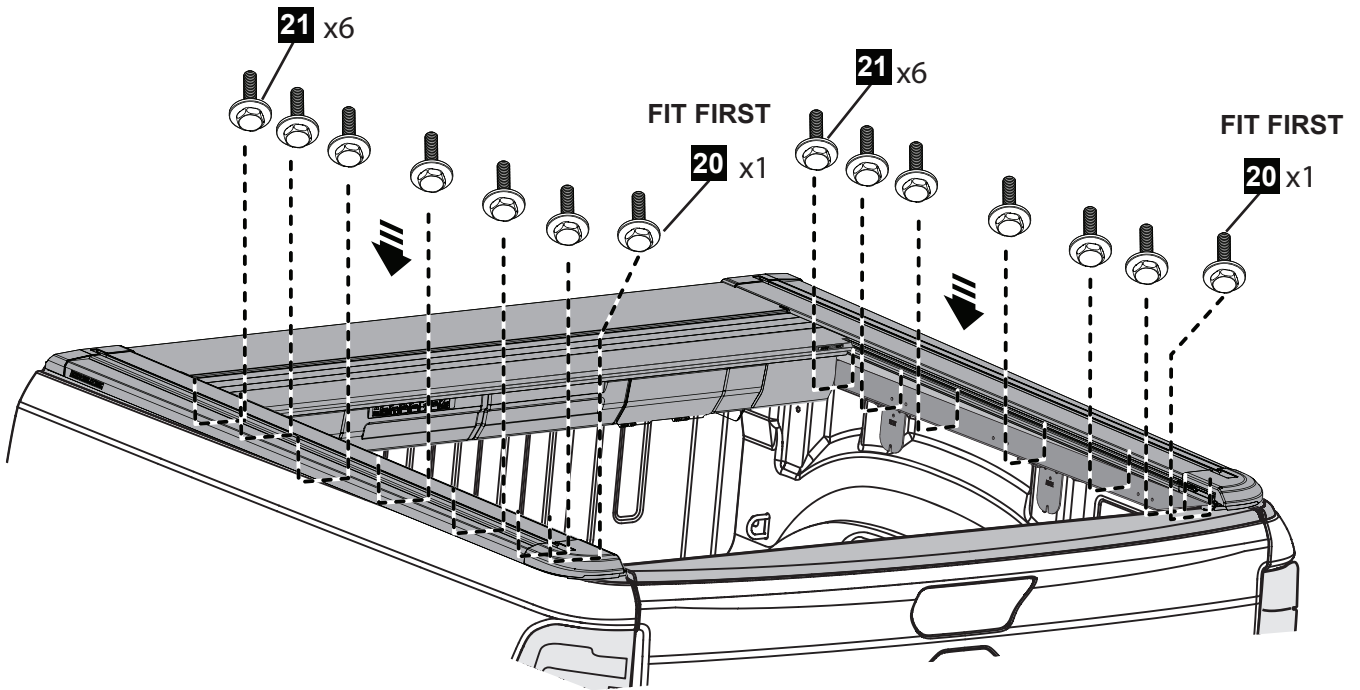

- 3** Assemble the Rolltrac side rail to the mount extrusion with screws on each side as shown, tighten loosely. Inside the side rails line up sliding nut plates before fitting screws.

### PERFORM FITMENT CHECK



**A = A    B = B**

LIFT UP THE HANDLE AND  
PUSH THE COVER MANUALLY

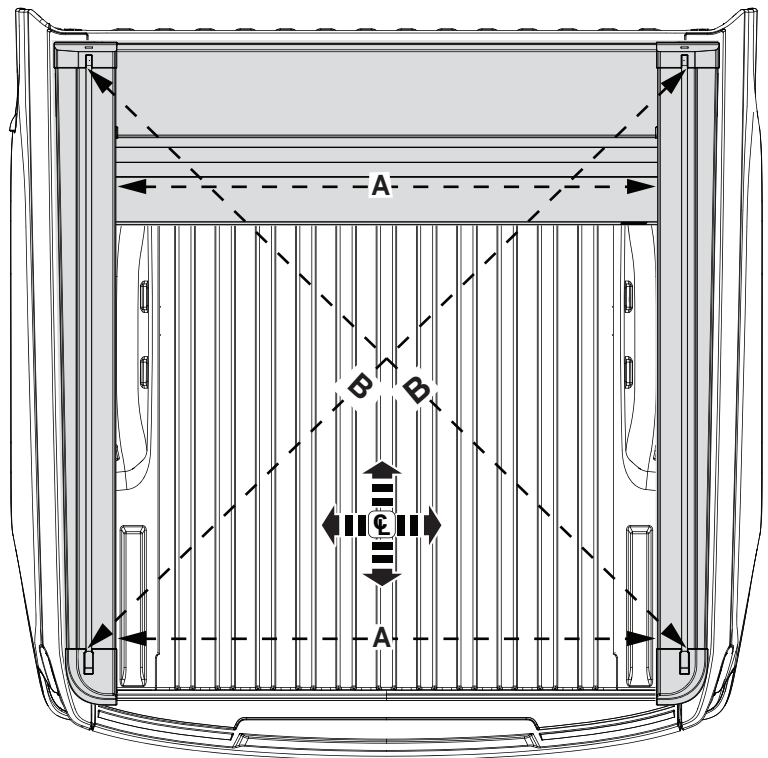
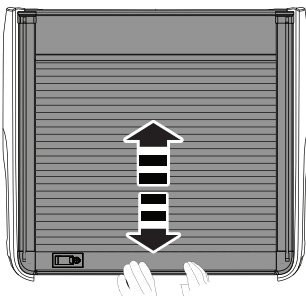
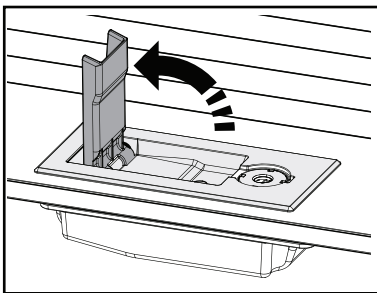

- 4** Perform width check (using canister end as reference) and diagonal fitment check (mounting bolts may need loosening for adjustment). Open and close the cover by hand, checking for smooth operation and consistent 1.5-2.0mm side to side free-play of slat assembly within side rails. If there are any tight spots, then check side rail position and re-adjust side rail width as required.

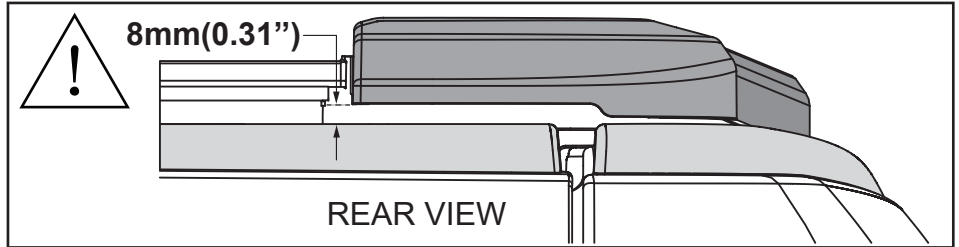
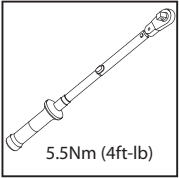

VIEW UNDER THE SIDE RAIL RHS (TUB NOT SHOWN FOR CLARITY)

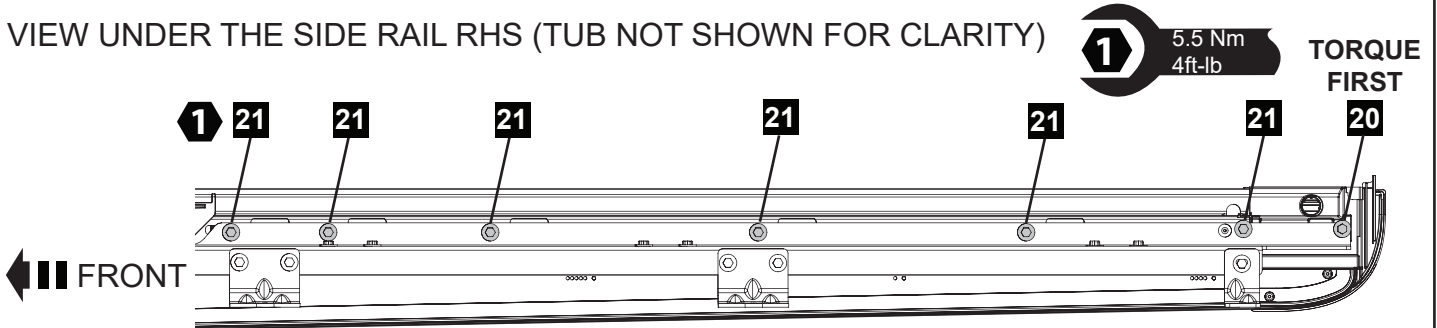

**5** Working from RHS to LHS (to avoid one side lifting up) torque all screws (21)&(20) to 5.5Nm(4ft-lb). Perform final fitment check as per step 4. **IMPORTANT:** Check the clearance between rear corner casting and top of tailgate, target is 8mm.(0.31") Open and close the tailgate to check function of seal (makes contact with tailgate and does not over compress) if position requires adjustment refer to steps 10-13 (section A).

CONNECT FRONT DRAIN TUBES TO CANISTER

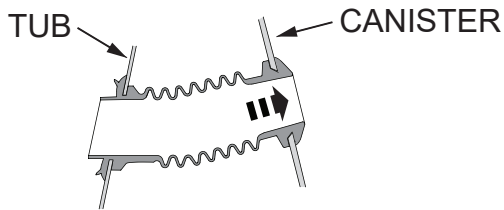

FIT REAR DRAIN TUBES TO SIDE RAILS

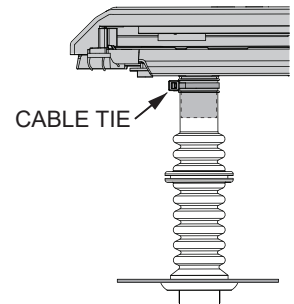

**6** Connect the front drain tubes to the canister. Connect the rear drain tubes to side rails and secure with cable ties.

THIS SECTION LEFT INTENTIONALLY BLANK

## SILICONE LUBRICATION TO THE SPIRALS (MODELS MAY VARY, IMAGES FOR REFERENCE ONLY)

- 1** Open tailgate and EGR RollTrac

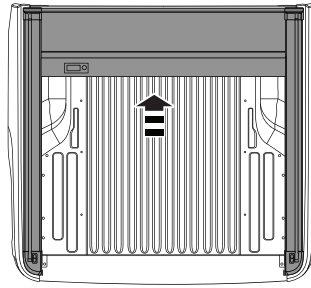
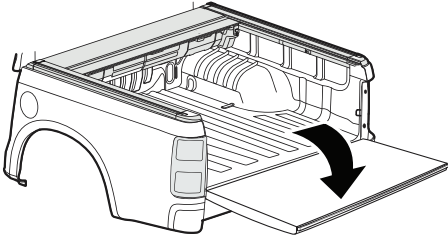

### TOOLS REQUIRED:

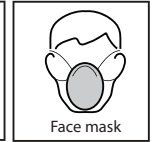
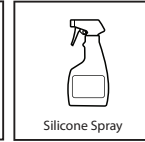
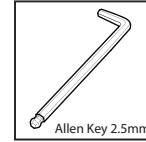

- 2** Using a 2.5mm Allen Key remove the 4 screws and open the inspection covers.  
**WARNING:** Keep clear of moving parts and avoid unnecessary operation of the EGR RollTrac while inspection covers are open.

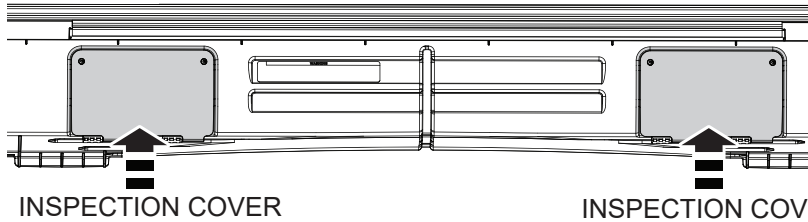

- 3** Close the EGR RollTrac to access canister internals

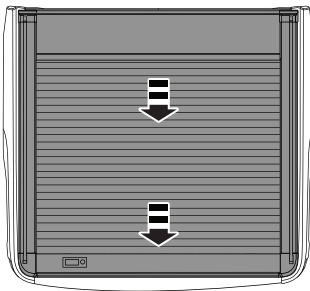

- 4** To avoid water leaks, look into the inspection points and check that the flanges of both front drain tubes are correctly engaged to the canister cover (without any kinking etc.), readjust if required.

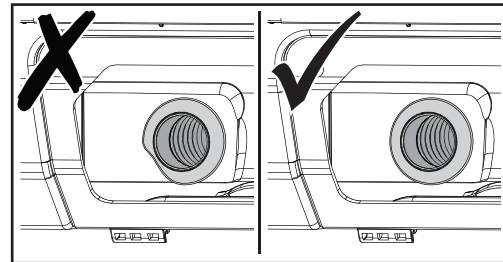

- 5** Using plastic compatible 100% Silicone Spray (ONLY) spray onto the spirals on both ends of the canister through the inspection points.

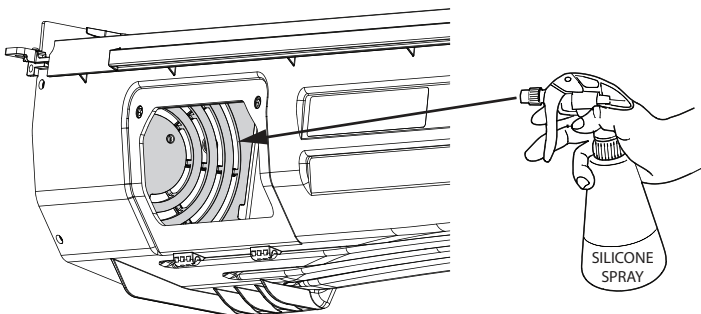

- 6** Open the EGR RollTrac

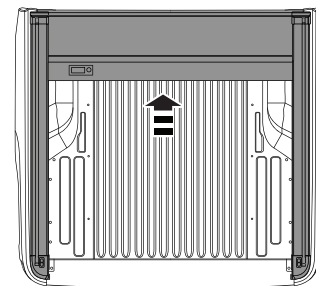

- 7** Close the inspection covers and secure with retained screws. Open and close the EGR RollTrac to distribute lubricant and check operation.

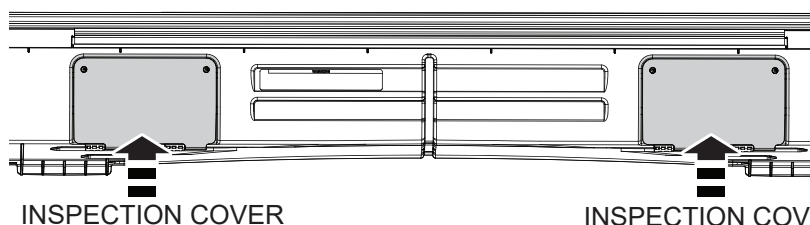

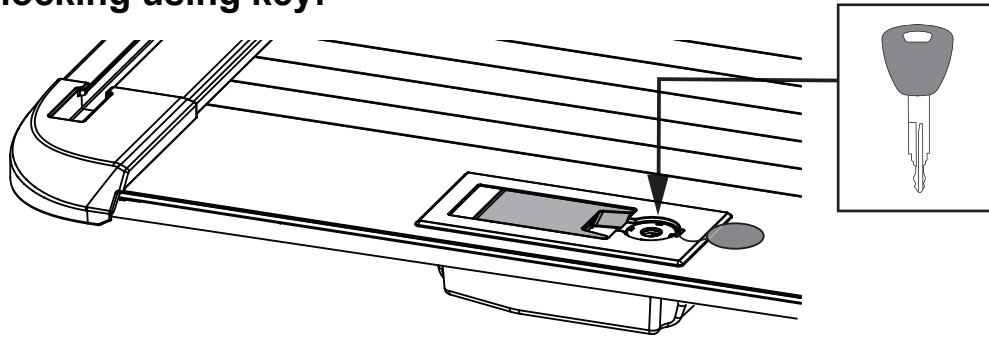
**Locking / unlocking using key:**

1. Ensure the EGR RollTrac handle is down.
2. Open the rubber cap covering the lock and using the provided key turn LEFT (CCW) to lock and RIGHT (CW) to unlock the hand rail.
3. Ensure the lock cap is pushed down to seal the lock.  
**Note:** handle must be folded down prior to locking / unlocking with key. Ensure the lock cap is pushed down to seal the lock after every use.

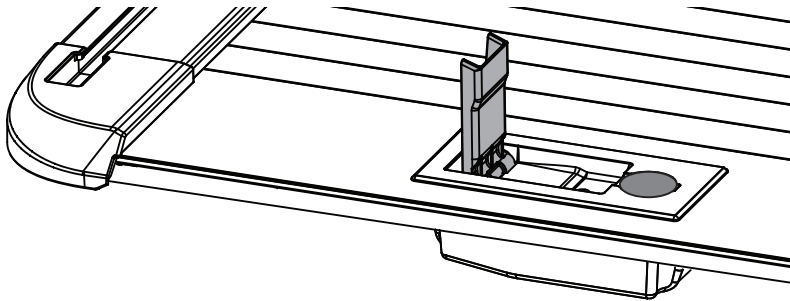
**Opening & Closing Procedure:**

1. Ensure the EGR RollTrac is unlocked.
2. Lift the handle 90 degree up, in order to release the latches from the tailgate rail and open the vehicle tailgate. Lifting the handle to 90 degrees will provide a hand hold so that the user can pull the cover into the next index position.
3. To ensure the EGR RollTrac is properly engaged in the desired position, gently push the handrail at both ends, if excessive movement is observed reposition the hand rail as required.

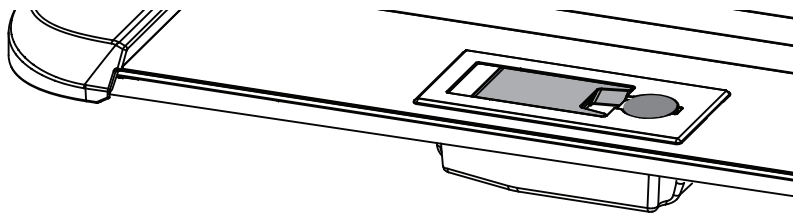

4. Set the hand rail to desired position and fold the handle down.  
**NOTE:** Cover should open and close smoothly. If cover does not lock or open correctly, please refer to the trouble shooting section in the Owners Manual.

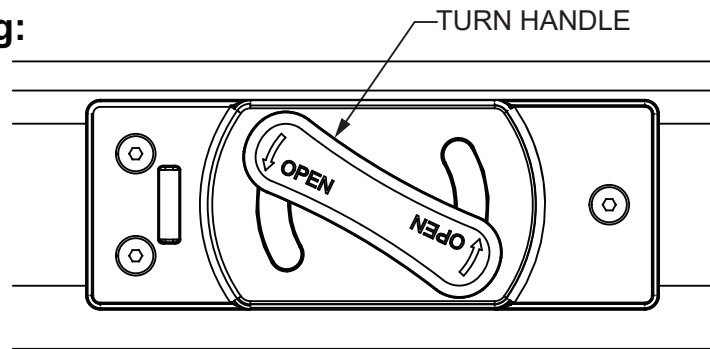
**Emergency Opening:**

Turn the emergency release handle located on the centre of the hand rail assembly and retract the EGR RollTrac.

## RIVETING SIDE BRACKETS

ROLLTRAC NOT SHOWN FOR CLARITY (RHS)

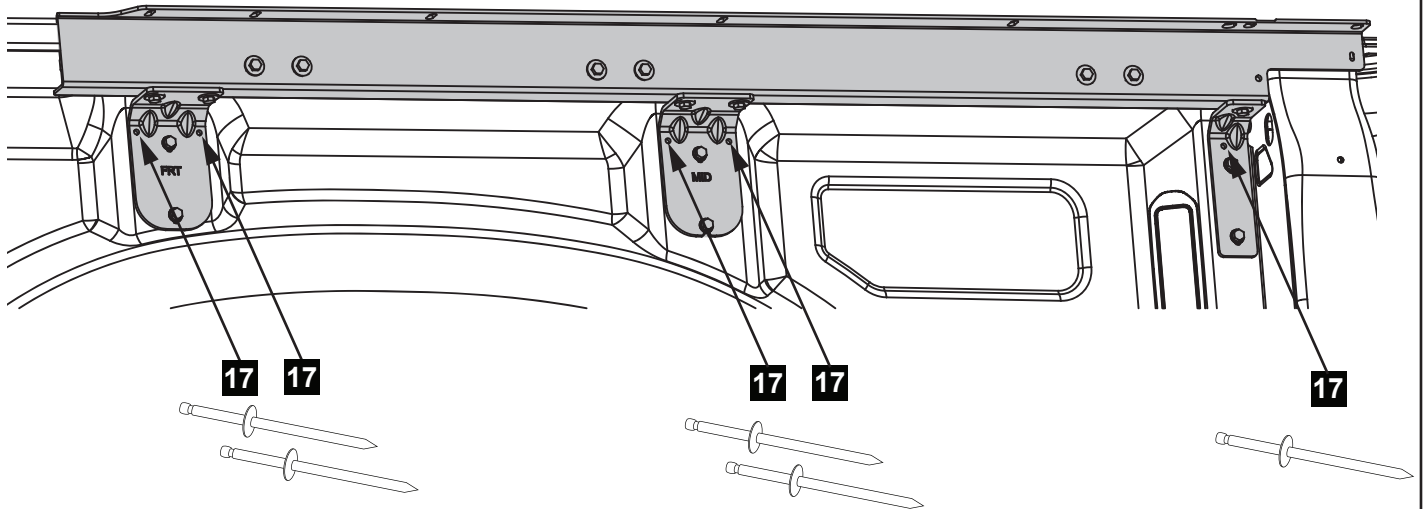

- 1 After running all fitment checks, drill the 5 hole locations using 5mm(13/64") drill bit. Secure the brackets with rivets as shown. Repeat for LHS. NOTE: Apply rust inhibitor to drilled holes.

## FINAL NOTES

Dispose of all packaging and waste according to local regulations.  
Retain your Owners Manual, Fitting Instructions and fitting jigs for future reference.  
Refer to Owners Manual for operation, warranty, service and product care guidelines.  
Complete the installation check list in Owners Manual and store keys safely.  
Clean the EGR RollTrac using multi purpose cleaner to remove any residue from packaging and installation.