

EGR

INSTALLATION INSTRUCTIONS

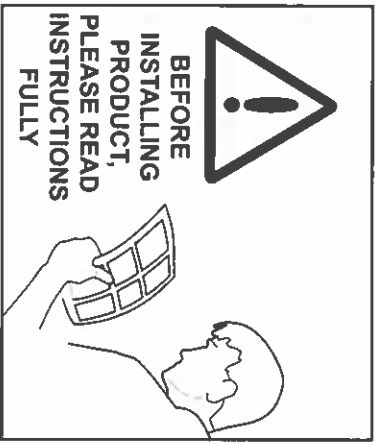

Cleaning Notes

- Spray with a firm water spray to remove any loose dirt.
- Wash with water, detergent and a soft cloth or sponge.
- Do not use petroleum based solvents or abrasives.
- Do not drive for four hours after installation.
- Do not use automatic car wash.

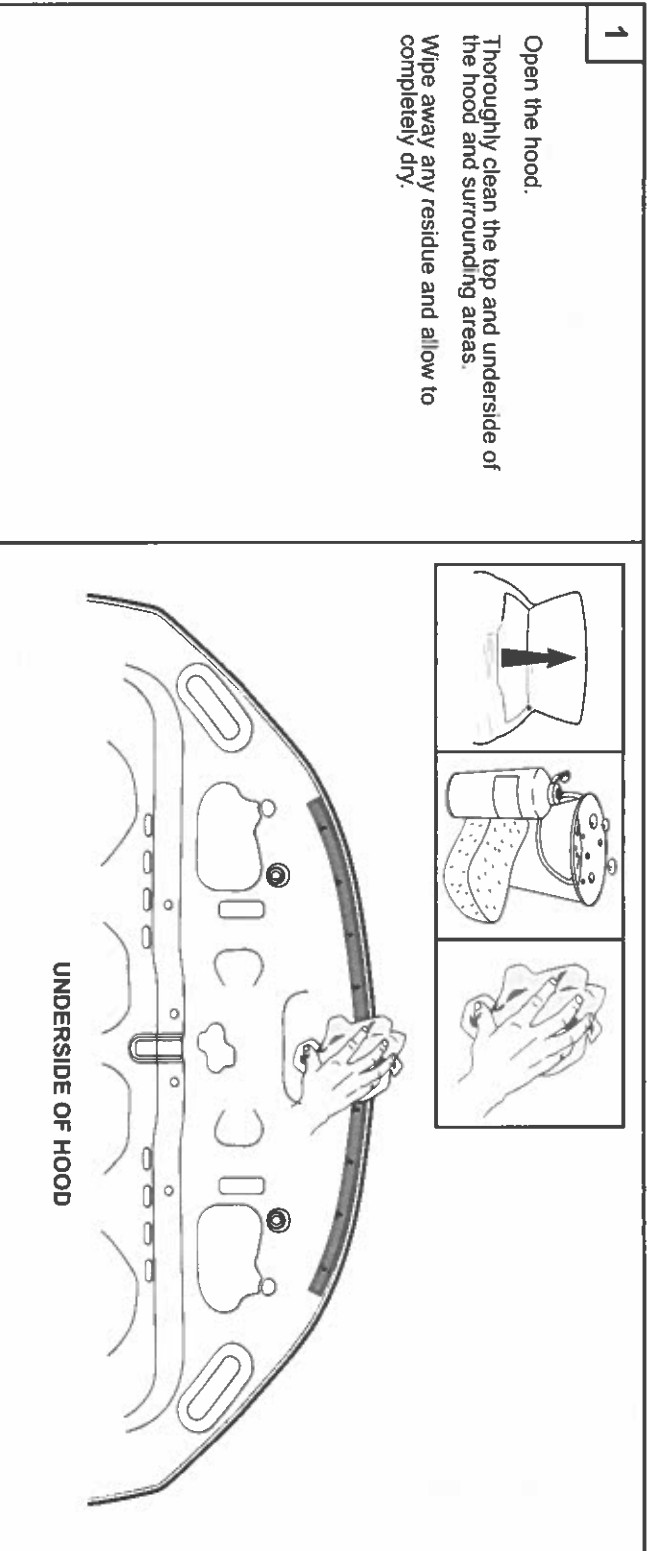
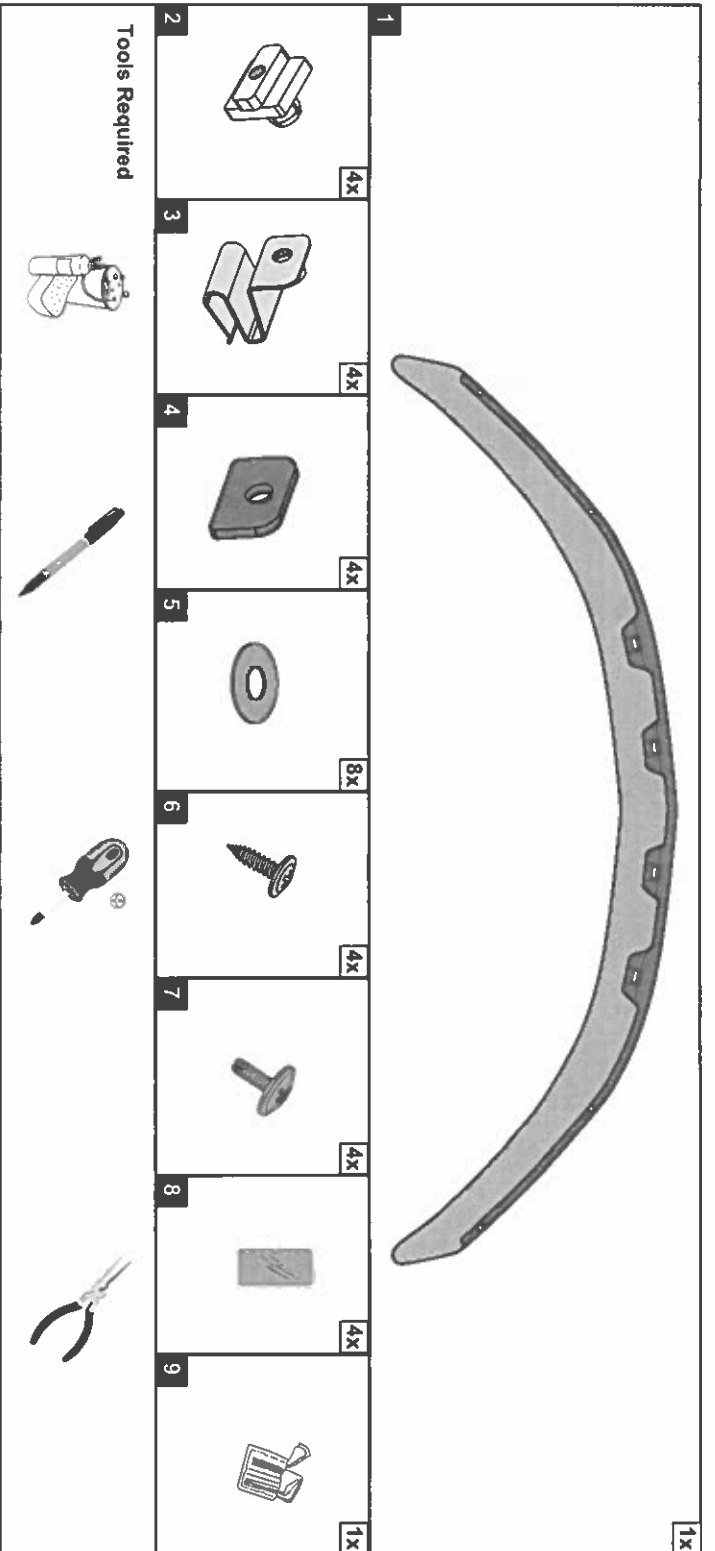
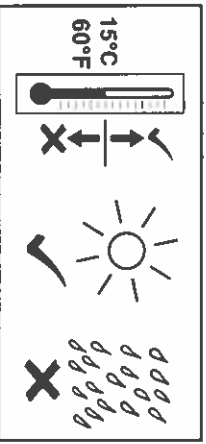
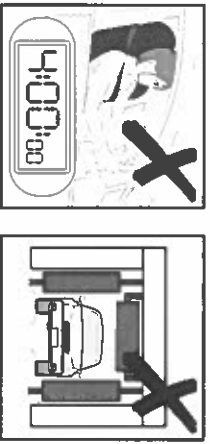

For Technical Support/Warranty Information please call: 800-757-7075

EGR

INSTALLATION INSTRUCTIONS

2

Trial fit the hood protector centrally onto the hood.

With a non-permanent marker, note and mark the positions of the four acrylic tag slots in the hood protector onto the hood where they correspond to the rubber trim retaining plugs.

Note and mark the positions of the four outer holes in the hood protector onto the hood. Remove the hood protector.

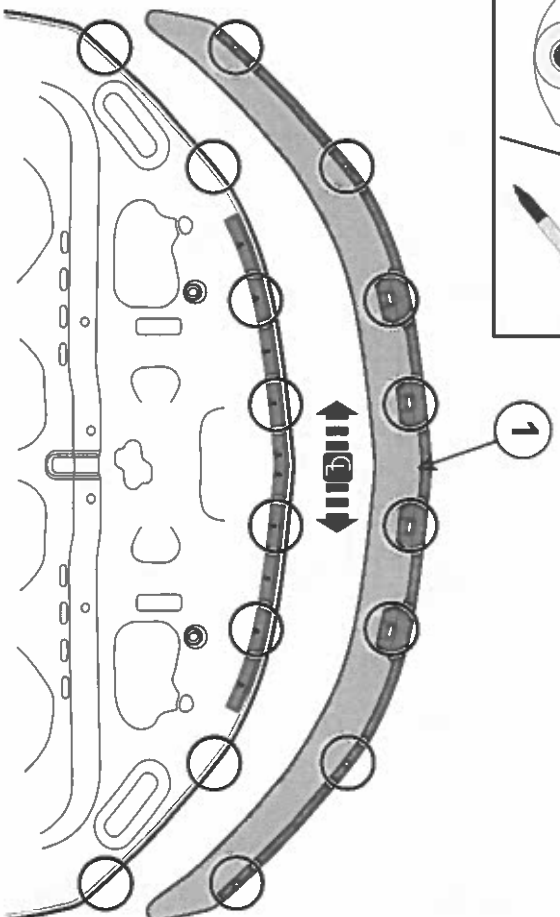
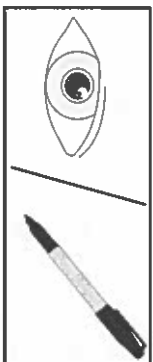

3

At the four hole locations, clean the noted areas with alcohol prep pad provided.

Wipe off any residue with a dry clean cloth. Adhere the abrasive resistant tape strips over the hood lip.

Apply tape so approximately half of each strip is adhered to the topside and half is adhered to the underside of hood.

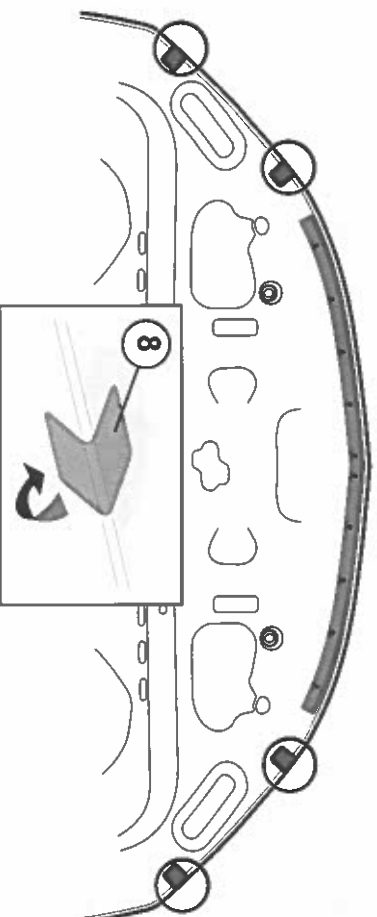

EGR

INSTALLATION INSTRUCTIONS

4

Attach the neoprene washers to the face of the metal wing clips.

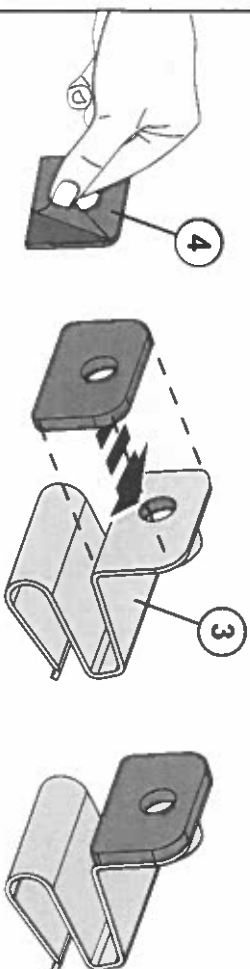

5

Slide the metal wing clips over the abrasive resistant tape strips on the hood edge at the four previously noted hole positions.

IMPORTANT: Ensure the clips rest over the abrasive resistant tape and do not come in contact with hood paint work. Failure to do this may result in permanent paint damage.

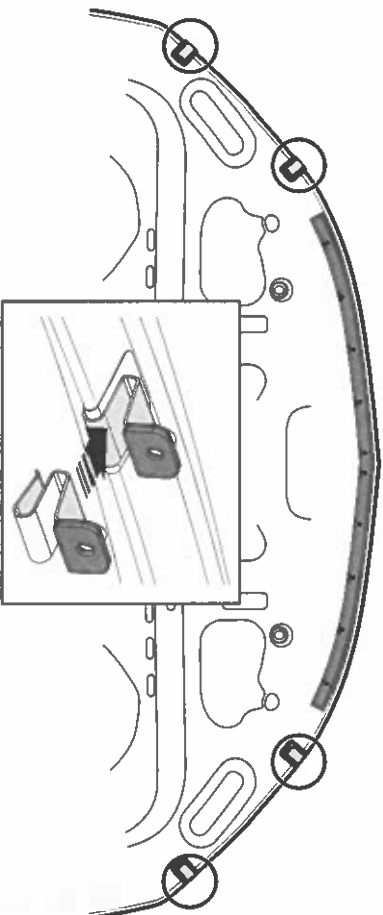

6

Using pliers, remove the four rubber trim retaining plugs and discard.

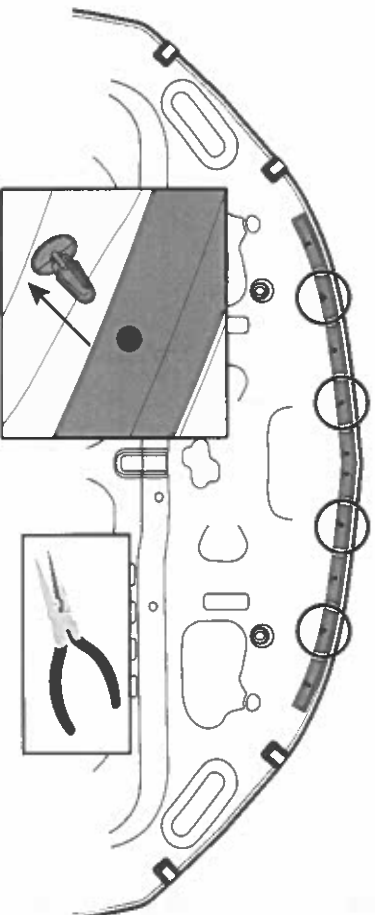

EGR

INSTALLATIONS INSTRUCTIONS

7

Pull down the seal and insert the four screw plugs provided into the four vacant holes.

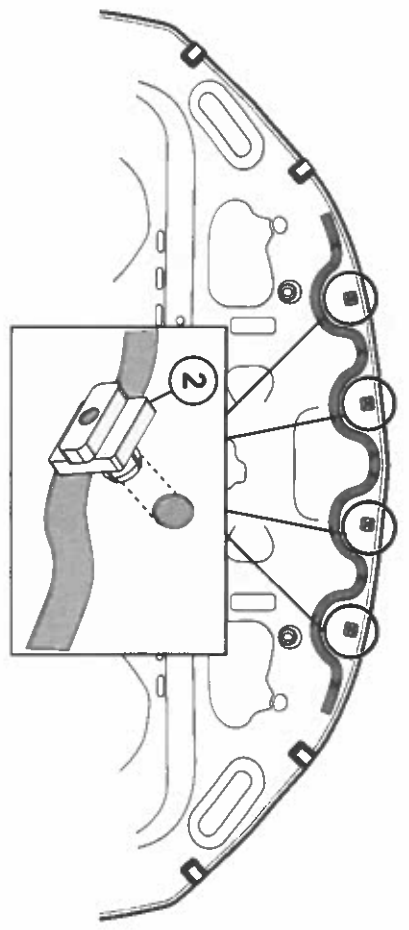

8

Install the hood protector onto the hood ensuring that the collar of the screw plugs locate into and parallel with the slots in the hood protector tags.

Return the rubber trim to its original position and ensure it is sitting over the acrylic tags of the hood protector.

Important: Rubber trim must be sitting over hood protector acrylic tags.

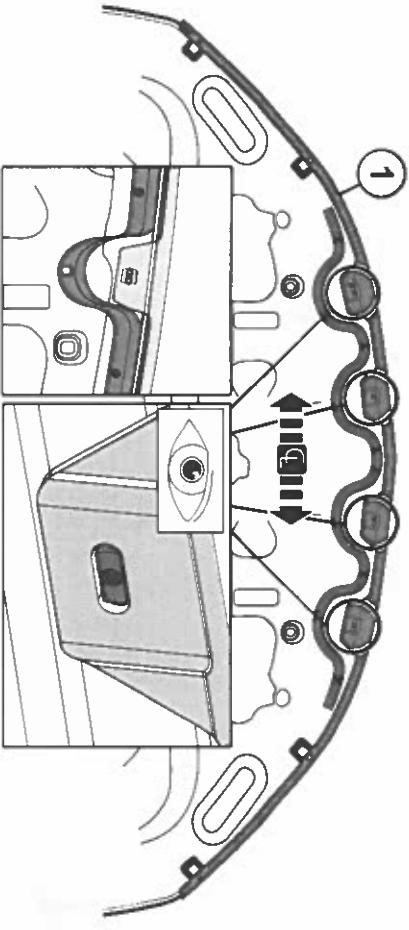

9

While maintaining thumb pressure against the underside of the hood protector, insert the large screws with the large washers through the rubber trim and into the screw plugs.

Do not fully tighten yet. Ensure the hood protector is centralized on hood then fully tighten screws.

Important: Thumb pressure must be maintained on the hood protector to prevent the screw plug from rotating. **DO NOT OVERTIGHTEN SCREWS.**

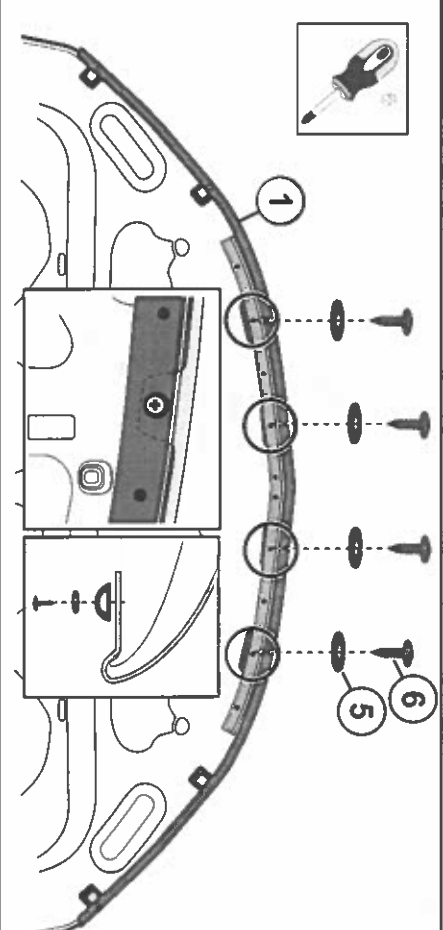

EGR

INSTALLATION INSTRUCTIONS

10

Secure the hood protector to the wing clips with the small screws and washers provided.

TO REMOVE: Reverse the above procedures.

