

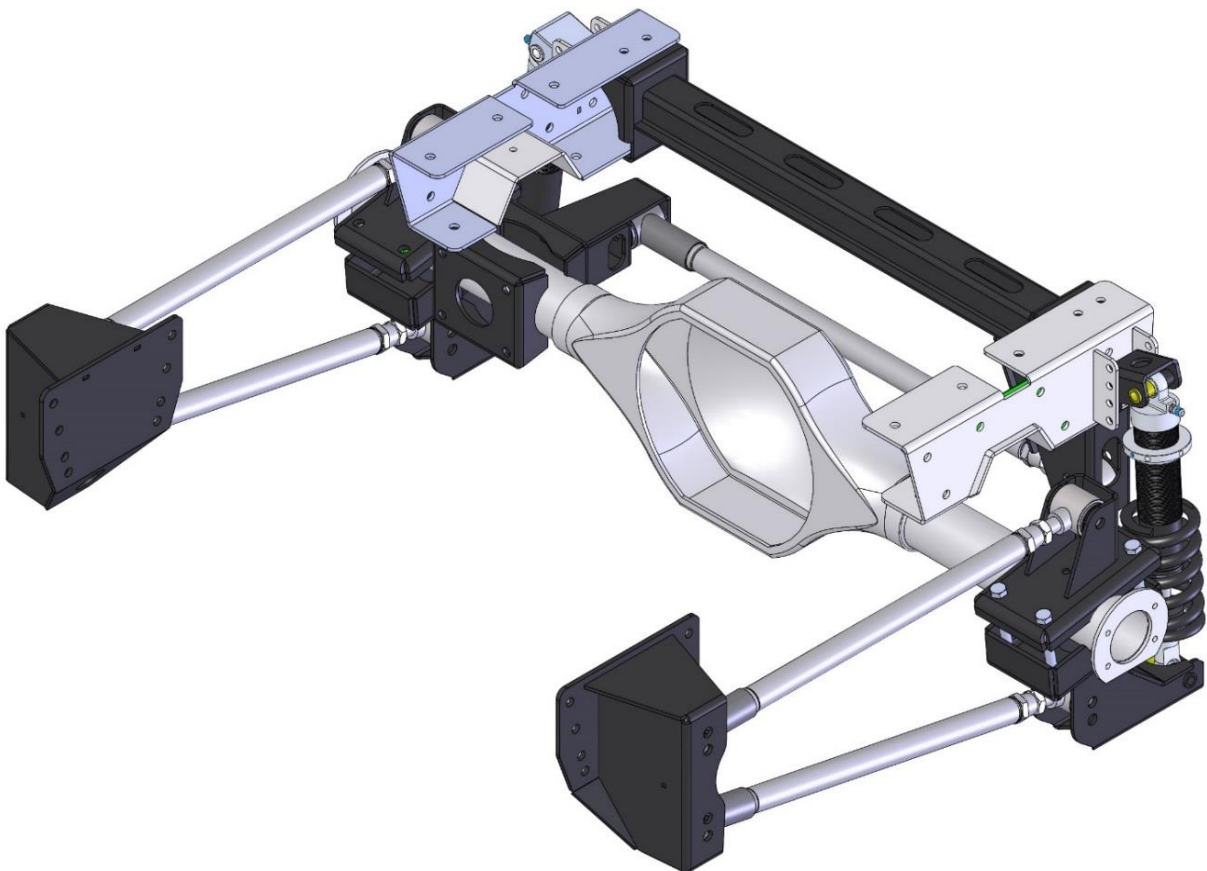

Detroit Speed, Inc.
QUADRALink Rear Suspension
1973-87 GM Square Body Truck
P/N: 041750, 041751 & 041752

The Detroit Speed QUADRALink is a great way to upgrade from a trailing arm rear suspension. Detroit Speed's exclusive 4-link geometry design is uncompromised and designed to achieve the best possible handling during all conditions. The patented "Swivel-Link" technology in combination with tuned high-durometer rubber bushings allow the suspension to fully articulate with smooth silent motion. This system utilizes a horizontal track bar that provides precise and effective rear axle lateral location during hard cornering. The track bar is adjustable for roll center control at various ride heights, and the rear cross-members add strength and rigidity to the rear body and frame section.



PN: 041750 Shown

IMPORTANT:

All work should be performed by a qualified welder and technician. Please read the entire set of instructions and fully understand all of the steps involved before beginning the project. Always make sure to wear the appropriate safety equipment for the job and properly support the vehicle. If you have any questions before, during, or after the installation, feel free to contact Detroit Speed by phone at (704) 662-3272 or by email at tech@detroitsspeed.com.

Item #	Description	Quantity
1	Track Bar Crossmember Assembly	1
2	Track Bar Axle Bracket Assembly	1
3	Track Bar Axle Bracket Clamp Assembly*	1
4	Frame Bracket Assembly, LH & RH	2
5	Lower Axle Bracket Assembly*	2
6	Upper Axle Bracket Assembly*	2
7	Upper Shock Mount Assembly	2
8	Frame Notch Assembly, LH & RH	2
9	Upper/Lower Swivel-Link Assembly	4
10	Track Bar Swivel-Link Assembly	1
11	Coilover Shock	2
12	Coilover Spring - 10" x 2.5"ID x 200 lbs.	2
13	Hardware Kit	1
14	Instructions	1

*Not Required with PN: 041751 - These items are are replaced by 2 upper/lower axle bracket assemblies

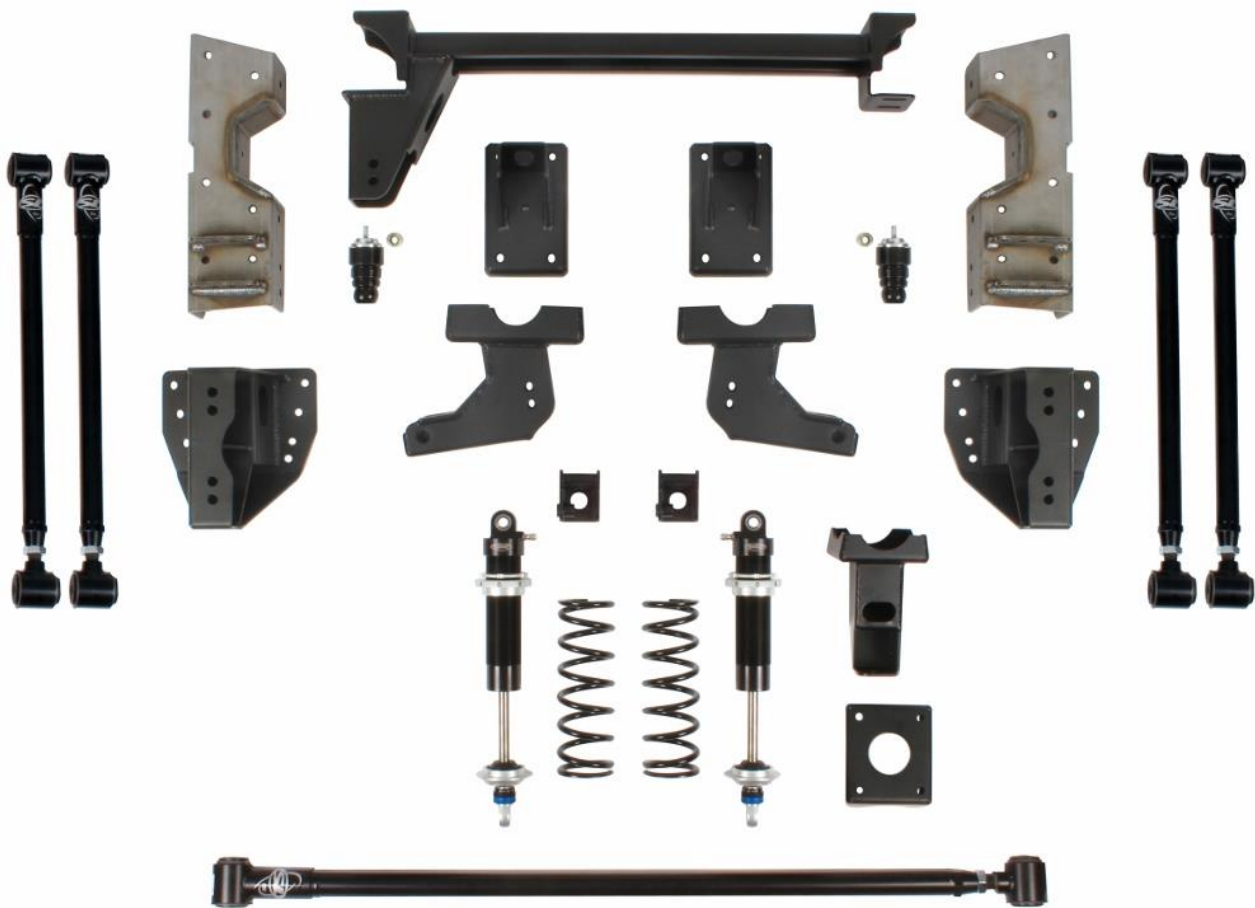

PN: 041750-S Shown

Hardware Kit Checklist – Detroit Speed Rear QUADRAlink Kit			
Part Number	Description	Quantity	Check
9304113	Swivel-Link Hardware Bag	1	
980034FS	9/16"-18 x 3-3/4"L Hex Head Bolt	10	
960022FS	9/16"-18 Nylock Nut	10	
970020FS	9/16" SAE Washer	20	
9304395	Coilover Shock Hardware Bag	1	
980021FS	1/2"-20 x 3-1/2"L Hex Head Bolt	2	
980043FS	1/2"-20 x 4"L Hex Head Bolt	2	
960004FS	1/2"-20 Nylock Nut	4	
980125FS	3/8"-24 x 3-1/2"L Hex Head Bolt	4	
960032FS	3/8"-24 Nylock Nut	4	
970023FS	3/8" SAE Washer	8	
9304396	Axle Bracket Hardware Bag *	1	
980123FS	1/2"-20 x 6"L Hex Head Bolt	8	
960004FS	1/2"-20 Nylock Nut	8	
970037FS	1/2" SAE Washer	16	
980124FS	7/16"-20 x 5-1/2"L Hex Head Bolt	4	
960050FS	7/16"-20 Nylock Nut	4	
970042FS	7/16" SAE Washer	8	
9304394	Installation Hardware Bag	1	
99030022	Upper Shock Spacer – 3/4"OD x 1"L	2	
99030475	Lower Shock Spacer – 3/4" OD x 1.25"L	2	
99040637	Frame Notch Template	1	
99030336	Jounce Bumper Spacer	2	
030504	Jounce Bumper	2	
9304397	Frame Bracket Hardware Bag	1	
950042FS	7/16"-20 x 1-1/4"L Hex Head Bolt	16	
980051FS	7/16"-20 x 1"L Hex Head Bolt	24	
960050FS	7/16"-20 Nylock Nut	40	
970042FS	7/16" SAE Washer	80	
980035FS	3/8"-24 x 1-1/4"L Hex Head Bolt	8	
960032FS	3/8"-24 Nylock Nut	8	
970023FS	3/8"-24 SAE Washer	16	
960033FS	5/16"-18 Nylock Nut	2	
970027FS	5/16" SAE Washer	2	

***Not Required with PN: 041751**

Fastener Torque Specifications	
Application	Torque (ft-lbs)
Swivel-Link Axle Bracket Assembly*	40
Track Bar Axle Bracket Assembly*	35
Frame Notch Assembly	50
Track Bar Crossmember Assembly	30
Frame Bracket Assembly	50
Upper Shock Mount Assembly	30
Swivel-Link and Track Bar Bolts	110
Swivel-Link and Track Bar Jam Nuts	50
Upper & Lower Shock Bolts	60

***Not Required with PN: 041751**

Installation:

1. Raise the vehicle on jack stands so that the frame is level with the ground. Remove the bed from the vehicle. You may also need to remove the exhaust if necessary to make installation easier.
2. Remove the factory shocks from both sides of the vehicle. If your vehicle has an upper shock stud, remove them from both sides of the frame (Figure 1).

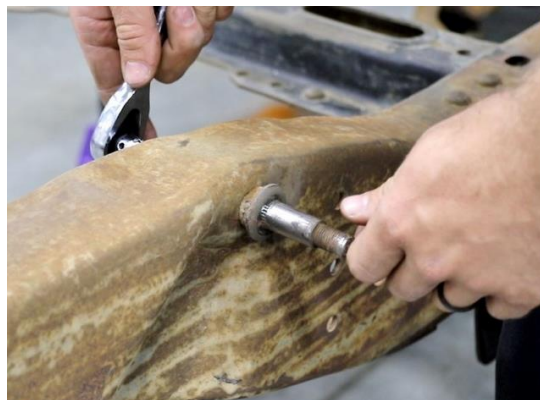

Figure 1 - Remove Shock Bolts

3. Remove the rear axle bumper bracket from both sides of the frame (Figure 2).

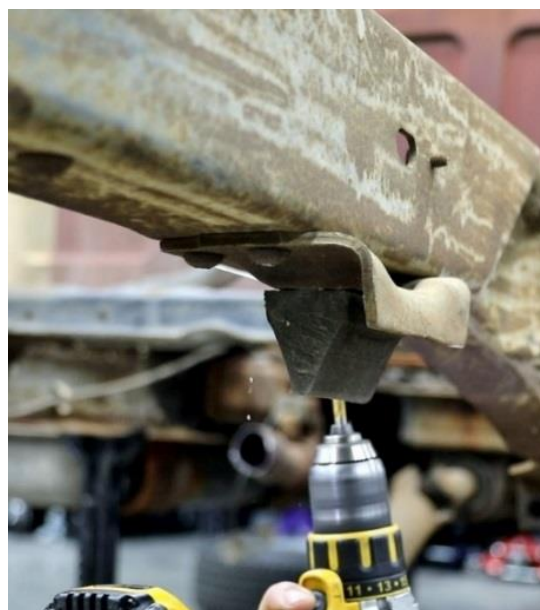

Figure 2 - Remove Rear Axle Bumper Bracket

4. Remove the stock leaf springs from the rear axle and frame. **NOTE:** Make sure the rear axle is supported so the rear brake lines are not in tension. If you have purchased PN: 041751, remove the rear axle from the vehicle. Remove the front and rear leaf spring brackets from both sides of the frame (Figure 3 & 4).



Figure 3 - Front Leaf Spring Bracket



Figure 4 - Rear Leaf Spring Bracket

5. With the rear frame rails level, locate the centerline of the frame notch location on the side of the frame. Using the top rear hole of the front leaf spring bracket, measure back $21\text{-}3/8$ ". Mark this centerline location (Figure 5). **NOTE:** Make sure the tape measure is level when you mark this location.



Figure 5 - Locate Notch Centerline

6. Use a straight edge and extend your centerline along the side of the framerail. Center the provided template on the side of the frame. Line up the top edge of the template with the top of the framerail (Figure 6).

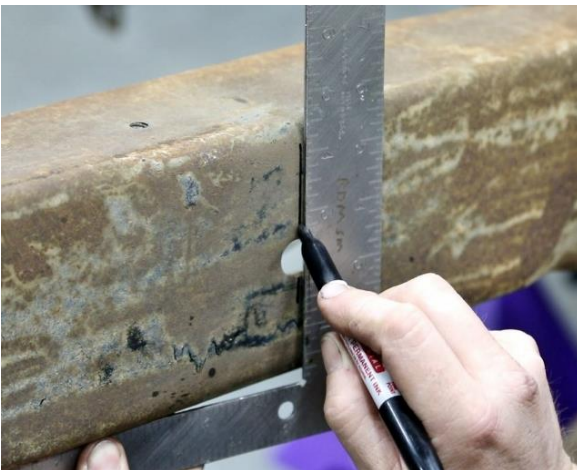

Figure 6 - Frame Notch Template

7. Use the template and trace the frame notch cutout onto the side of the framerail. Use a straight edge and transfer the cut lines to the bottom side of the framerail (Figure 7).



Figure 7 - Trace Frame Notch Cutout

8. Cover the fuel tank(s) with a welding blanket and cut along the traced lines to notch the framerail. Grind all edges smooth (Figure 8). Repeat steps 5-8 for the opposite side of the frame.



Figure 8 - Notch Frame Rail

9. Locate the frame notch bracket assemblies from the kit. There is a left and right hand side bracket so make sure you use the correct bracket for the correct side of the frame (Figure 9). **NOTE:** These frame notch bracket assemblies have been already painted for final assembly.

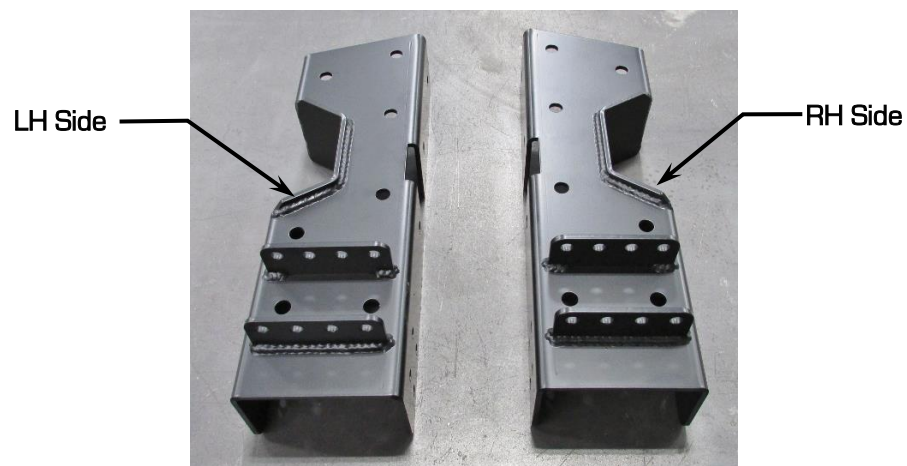

Figure 9 - Frame Notch Assembly

10. Test fit the frame notch assembly to the frame. Trim and grind any material away if needed so the frame notch assemblies fit tight to the frame rails.
11. Once the frame notch assemblies fit around the framerrails, transfer punch the framerrails using the frame notch assemblies as templates. There will be twelve locations to mark for 7/16"-20 hardware for the top, bottom and outside frame rail for each side. You will also need to transfer punch the four locations to mark the 3/8"-24 hardware for the top and bottom frame rail for each side.
12. Remove the frame notch assemblies and drill out all twelve locations on each framerrail for the 7/16"-20 hardware to a final drill size of 15/32". Drill out the four locations on each framerrail for the 3/8"-24 hardware using a final drill size of 13/32" (Figure 10).



Figure 10 - Drill Frame Rail

13. Once all hole locations are drilled out, install the frame notch bracket assemblies to the frame using the provided 7/16"-20 x 1"L hex head bolts, Nylock nuts and washers (Figure 11). Use anti-seize on the threads of the bolts. **NOTE:** Detroit Speed recommends painting or powdercoating the frame notch bracket assemblies before final installation. Torque to 50 ft-lbs. Do not install the 3/8"-24 hardware at this time.



Figure 11 - Install Frame Notch Assemblies (LH, Driver Side)

14. Place the jounce bumper spacer over the threads of the jounce bumper. Install the jounce bumper and spacer into each frame notch assembly at the C-notch using the provided 5/16"-18 Nylock nut and 5/16" washer and tighten (Figure 12).



Figure 12 - Install Jounce Bumper

15. Slide the track bar crossmember assembly in between the frame rails. The crossmember will locate between the frame notch assemblies and line up with the holes you drilled on the top and bottom side of the frame rails for the 3/8"-24 hardware (Figure 13). **NOTE:** The track bar mount will be located on the driver side of the frame.

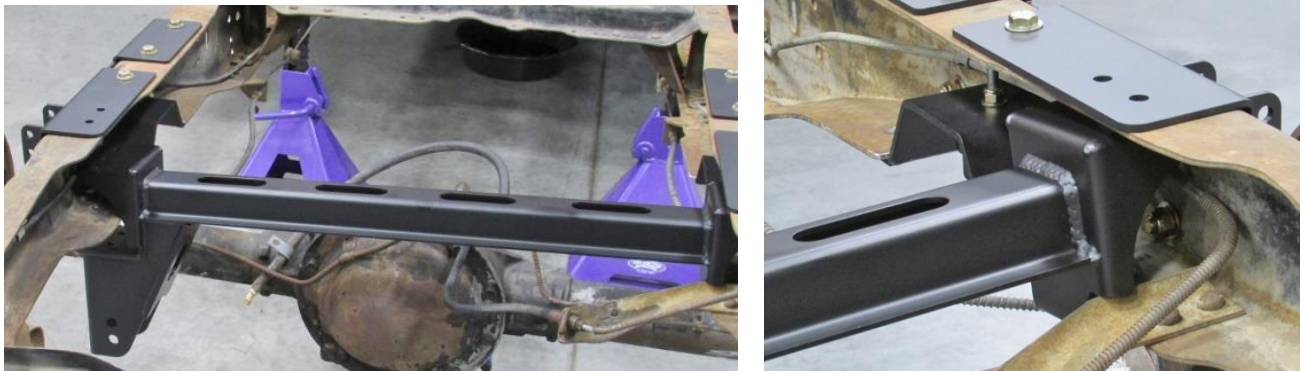

Figure 13 - Position Crossmember Assembly

16. Install the track bar crossmember to the frame by using the eight provided 3/8"-24 x 1-1/4"L hex head bolts, Nylock nuts and washers. Use anti-seize on the threads of the bolts. Install the left hand side hardware first and then the hardware on the right hand side, as those holes are slotted on the bottom. The bolts will need to be installed from the bottom on the bottom frame side and from the top on the top frame side (Figure 14). Torque to 30 ft-lbs.



Figure 14 - Install Track Bar Crossmember

17. Locate the upper shock mount assemblies to the frame notch assemblies. The upper shock mounts will slide between the tabs of the frame notch assemblies. **NOTE:** There are three different height options to install the upper shocks mounts. Detroit Speed recommends using the middle height hole locations as this will be your nominal setting.
18. Bolt the upper shock mounts in place using the provided 3/8"-24 x 3-1/2"L hex head bolts, Nylock nuts and washers (Figure 15). Use anti-seize on the threads of the bolts and torque to 30 ft-lbs.



Figure 15 - Install Upper Shock Mounts (RH, Passenger Side)

19. Locate the frame bracket assemblies from the kit. There is a left and right hand side bracket so make sure you use the correct bracket for the correct side of the frame (Figure 16).

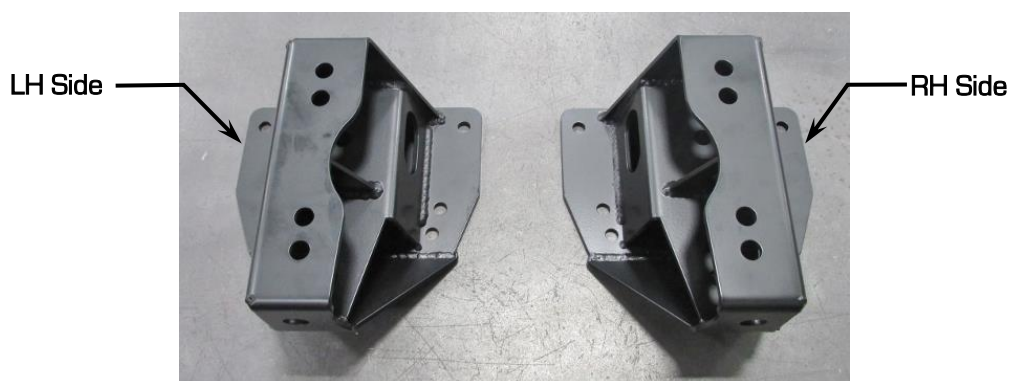

Figure 16 - Frame Bracket Assembly

20. Prepare the frame rails to install the frame bracket assemblies. Drill out the six holes on each side of the frame where the factory front leaf spring brackets were installed, using a 15/32" drill size (Figure 17).



Figure 17 - Drill Out Frame Holes

21. Bolt the frame bracket assemblies to the frame in the same location as the factory leaf spring brackets. Use the provided 7/16"-20 x 1-1/4"L hex head bolts, Nylock nuts and washers to hold the frame brackets in place (Figure 18). Use anti-seize on the threads of the bolts. Do not torque at this time.

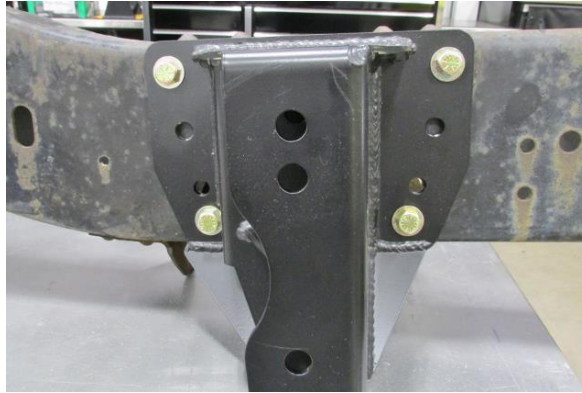

Figure 18 - Locate Mounting Holes

22. Two holes per frame rail will need to be drilled using the frame bracket assemblies as templates. Drill out these two holes in the frame rail to a final drill size of 15/32" (Figure 19).



Figure 19 - Drill Mounting Holes

23. Now that all the holes are drilled for the frame bracket assemblies, install them to the frame rails using the provided 7/16"-20 hardware. Use anti-seize on the threads of the bolts and torque to 50 ft-lbs (Figure 20).



Figure 20 - Install Frame Bracket Assembly

24. Prepare the factory rear axle tubes for the QUADRALink axle brackets. Cut off the factory lower shock mount from the passenger side of the rear axle. Grind smooth for a clean finish (Fig. 21).



Figure 21 – Cut Off Factory Lower Shock Mount (Passenger Side)

25. If you have purchased PN: 041750, continue on to the next step. If you have purchased PN: 041751, skip to **Step 28**. If you have purchased PN: 041752 or a rear end housing from Detroit Speed with the axle brackets already installed, skip to **Step 34**.

26. Place the upper axle bracket assemblies on top of the factory leaf spring pads (Figure 22) on both sides of the rear axle. The pin on the bottom side of the upper axle brackets will locate in the leaf spring pad on the axle tube.

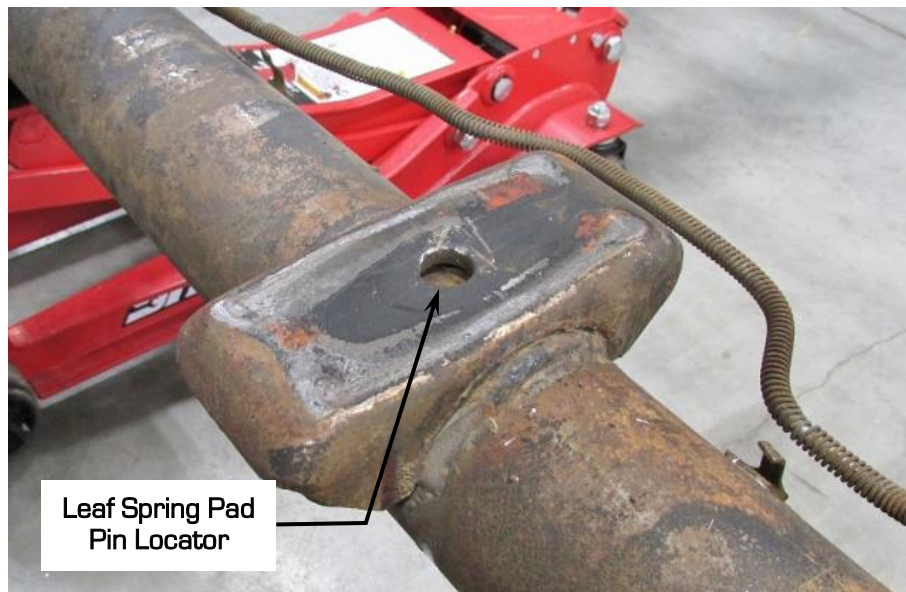

Figure 22 – Factory Leaf Spring Pad

27. Locate the lower axle bracket assemblies underneath the upper axle brackets. Bolt them together using the provided 1/2"-20 x 6"L hex bolts, Nylock nuts and washers (Figure 23 on the next page). Use anti-seize on the threads of the bolts. **NOTE:** Make sure that all four bolts are drawn up and tightened equally. The distance between the upper and lower axle brackets should be the same between the front and back side of the brackets so that they are parallel to each other. Torque to 40 ft-lbs. Skip to **Step 34**.



Figure 23 – Install Upper & Lower Axle Bracket (LH, Driver Side)

28. If you are building a custom axle, skip to the next step. If you are using a stock rear axle and will be replacing the housing ends, remove the rear axle from the vehicle. Remove the housing ends from the axle tubes. Remove the factory leaf spring pads from the axle tubes along with the driver side factory lower shock mount. Grind the factory welds on the axle tubes smooth for a clean finish. **NOTE:** The Detroit Speed axle brackets are designed for a 3" axle tube.
29. Using a pinion centering tool, measure from the centerline of the rear axle outward 21-1/4" in both directions and mark this location. This will be the location where the centerline of the upper and lower link axle brackets will be positioned (Figure 43). **NOTE:** Detroit Speed offers a pinion centering tool (PN: 070202) that will be helpful in placing your axle brackets in the correct location on your axle tube. Draw a scribe line around the axle tube at the marked locations.
30. Install the upper and lower link axle brackets over the axle tubes and center the brackets on the scribed circle on the axle tubes. Clamp the rear axle in place on a bench. Rotate the housing forward so that the center section mounting surface/rear cover surface is 0° to 2° from vertical depending on your preference. Install the provided 2.45"L weld spacers into the axle bracket upper and lower link holes along with the provided 9/16"-18 bolts.
31. Once the Swivel-Link axle brackets are in the correct location, tack weld them to the axle tubes. Verify the correct location and then finish weld all the way around the brackets to the axle tubes.
32. Locate the track bar axle bracket to the back side of the rear axle tube on the passenger side. The inside edge will be offset 13-13/16" outboard from the centerline of the rear axle (Figure 43). The surface with the track bar mounting hole will be perpendicular to the ground and square to the axle tube. Verify that the bracket is 90° to the axle tube and tack weld in place. Verify the correct location and finish weld all the way around the bracket to the axle tube.
33. Send the axle to a qualified shop to have the housing ends welded (if necessary). Check the axle tubes and have them straightened (if necessary). At this point, fabrication work is complete so you can paint or powdercoat your rear axle housing.

34. If you have removed the rear axle from the vehicle, position it back underneath the vehicle. Install the upper and lower Swivel-Links to the frame bracket assemblies using the provided 9/16"-18 x 3-3/4"L hex head bolts, Nylock nuts and washers (Figure 24). **NOTE:** There are two mounting holes in the frame bracket assemblies. Detroit Speed recommends using the lower set of mounting holes as this will be your nominal setting. Use anti-seize on the threads of the bolts. Do not torque at this time.



Figure 24 - Install Links into Frame Brackets

35. Install the upper and lower Swivel-Links into the rear axle brackets using the provided 9/16"-18 x 3-3/4"L hex head bolts, Nylock nuts and washers on both sides of the vehicle (Figure 25). **NOTE:** There are two mounting holes in the lower axle bracket assemblies. Detroit Speed recommends using the upper set of mounting holes as this will be your nominal setting. Use anti-seize on the threads of the bolts. Do not torque at this time.

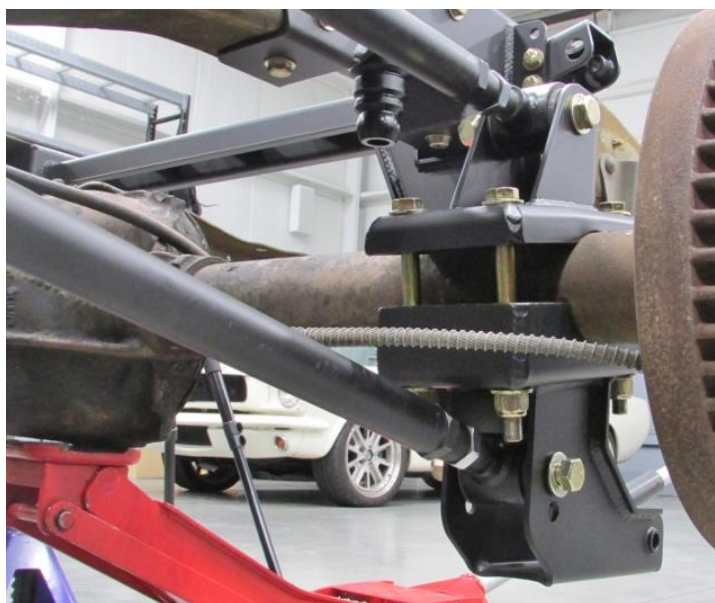

Figure 25 - Install Links to Axle Brackets (PN: 041750 Shown)

36. Use a floor jack to raise the rear axle so that the distance between the upper and lower shock mounting holes are 15" from center to center. This will be your nominal ride height. If you have purchased PN: 041751 or PN: 041752, skip to **Step 40**, otherwise continue to the next step.
37. Position the track bar axle bracket clamp plate assembly on the front side of the rear axle tube on the passenger side. It will locate against the inside of the link bracket assembly.

38. Position the track bar axle bracket assembly on the back side of the rear axle tube so it locates to the track bar clamp plate assembly. Bolt them together using the provided 7/16"-20 x 5-1/2"L hex head bolts, Nylock nuts and washers. Use anti-seize on the threads of the bolts and leave the hardware loose for now (Figure 26).

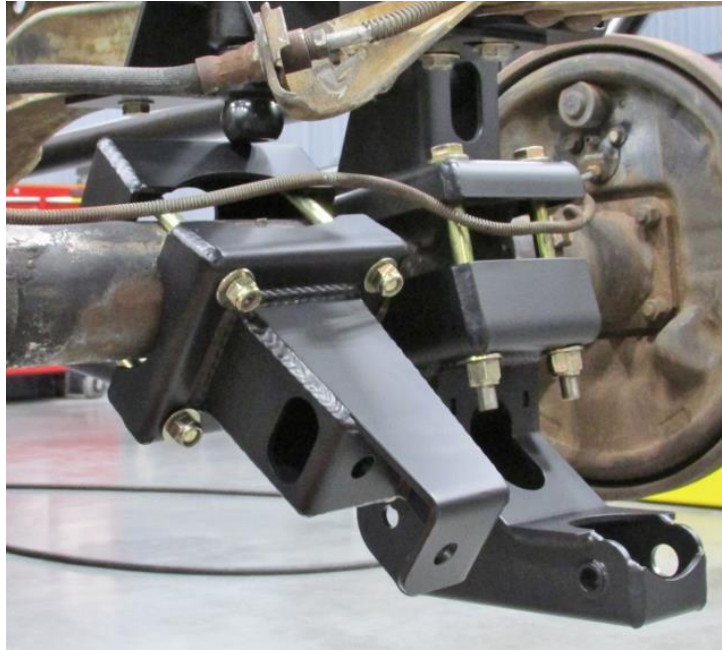

Figure 26 – Position Track Bar Axle Bracket

39. Locate the track bar axle bracket assembly against the inside of the passenger side link bracket assembly. Rotate the track bar axle bracket assembly so the surface with the track bar mounting hole will be perpendicular to the ground and square to the axle tube (Figure 27). Torque the 7/16"-20 hardware to 35 ft.-lbs. and re-check the track bar bracket to make sure it remains level. Check the pinion angle as it should be level to the ground (Figure 28).

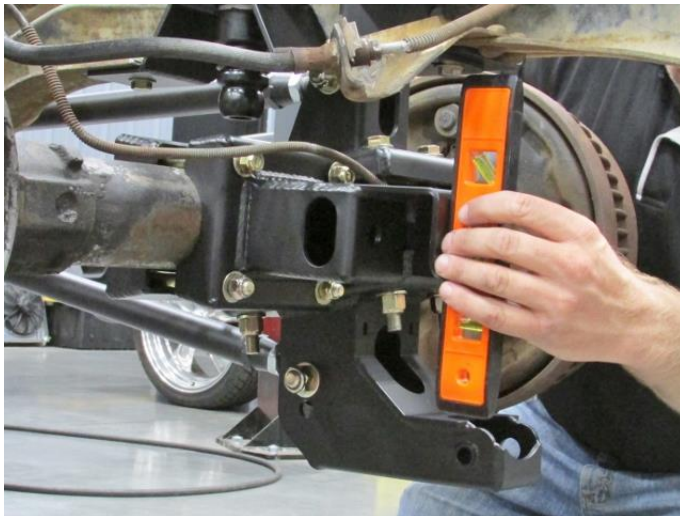

Figure 27 – Level Track Bar Axle Bracket



Figure 28 – Check Pinion Angle

40. Install the track bar Swivel-Link into the track bar crossmember assembly and then into the track bar axle bracket. Use the provided 9/16"-18 x 3-3/4"L hex head bolts, Nylock nuts and washers (Figure 29 on the next page). Use anti-seize on the threads of the bolts. **NOTE:** There are two mounting holes in the track bar crossmember assembly. Detroit Speed recommends using the lower mounting hole as this will be your nominal setting. The track bar should be level at ride height. Torque all 9/16"-18 Swivel-Link hardware to 110 ft.-lbs.

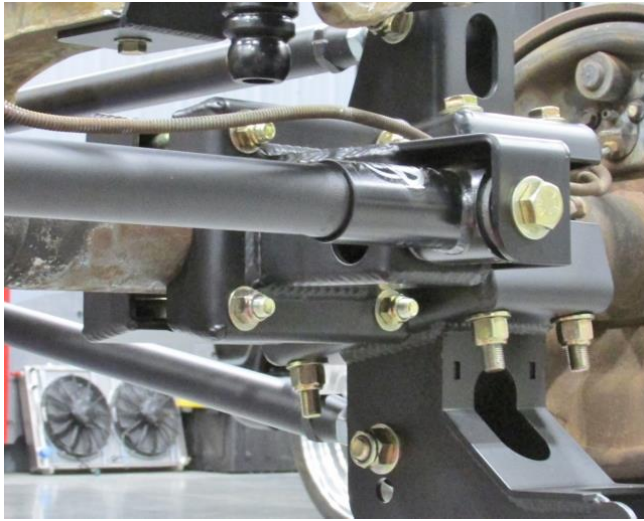

Figure 29 – Install Track Bar

41. Next, it is necessary to build each coilover shock and spring assembly before installing them into the vehicle. For the non-adjustable shocks, please use steps 42 through 44 to assemble each coilover shock. For the adjustable shocks, please use steps 45 and 46 to assemble each coilover shock.

42. Remove the white plastic from the spanner nut and loosely install the provided bolt into the spanner nut (Figure 30). Install the spanner nut over the top of the shaft side of the shock with the flat surface up and thread the spanner nut all the way to the bottom.



Figure 30 – Spanner Nut

43. Place one of the provided spring bearings (Figure 31) over the shock and onto the spanner nut followed by the coilover spring and then another spring bearing.



Figure 31 – Spring Bearing

44. Place the spring perch over the top of the shock and onto the coilover spring and bearing. Place the retaining ring over the shock and locate the ring into the groove. Press the spring perch up onto the retaining ring so it locks in place (Figure 32 & 33). Thread the spanner nut up to the spring so it stays in place on the shock. Skip to **Step 47**.



Figure 32 - Spring Perch & Retaining Ring



Figure 33 - Install Spring Perch

45. Remove the upper spring seat from the retaining ring using a rubber hammer and moving it down off the upper shock mount (Figure 34). Remove the retaining ring from the upper shock mount and pass the upper spring seat over the upper shock mount (Figure 35).



Figure 34 - Removing the Upper Spring Seat



Figure 35 - Upper Spring Seat & Retaining Ring

46. Thread the spanner nut all the way to the bottom of the coilover shock and slide the coilover spring over the top of the upper shock mount. Install the upper spring seat back over the top of the upper shock mount and re-install the retaining ring back onto the upper shock mount. Press the upper spring seat up onto the retaining ring so it locks in place. Thread the spanner nut up to the spring so it stays in place on the shock.

47. Install the provided 3/4" OD x 1"L upper shock spacer onto the provided 1/2"-20 x 3-1/2"L hex head bolt. Position the body side of the shock up to the upper shock mount. Apply anti-seize to the threads and install the bolt and spacer through the upper shock mount hole and through the monoball of the shock. Install the provided 1/2"-20 Nylock nut onto the bolt and tighten (Figure 36 on the next page).



Figure 36 - Install Coilover Shock into Frame Mount

48. Install the provided 3/4" OD x 1-1/4"L lower shock spacers onto the provided 1/2"-20 x 4"L hex head bolts. Adjust the height of the rear axle and install the lower shock bolts and spacers through the lower shock mounts and through the monoball of the shocks. Apply anti-seize to the threads of the bolts and install the provided 1/2"-20 Nylock nuts and tighten (Figure 37). **NOTE:** If you have the remote canister adjustable shocks, the adjustment window should be pointing to the rear of the vehicle. Torque the upper and lower shock bolts to 60 ft-lbs.



Figure 37 - Install Coilover Shock into Axle Bracket

49. Support the axle at ride height. Nominal ride height is 15" from center to center of the coilover shock mounting bolts. Check the axle position in the vehicle and adjust the links as necessary. **NOTE:** There can be no more than 2" of exposed threads on the end link (3/4" of thread engagement in the tube). This measurement does include the jam nut (Page 24).

50. The rear axle should be centered from side to side by adjusting the length of the track bar. The pinion angle should be level to the ground at nominal setting and adjusted with the upper links to your preference if necessary. The wheelbase should be measured and adjusted with the lower links (Figure 38). **NOTE:** 117.5" is the correct wheelbase for a short bed and 131.5" is the correct wheelbase for a long bed 1973-87 C10.

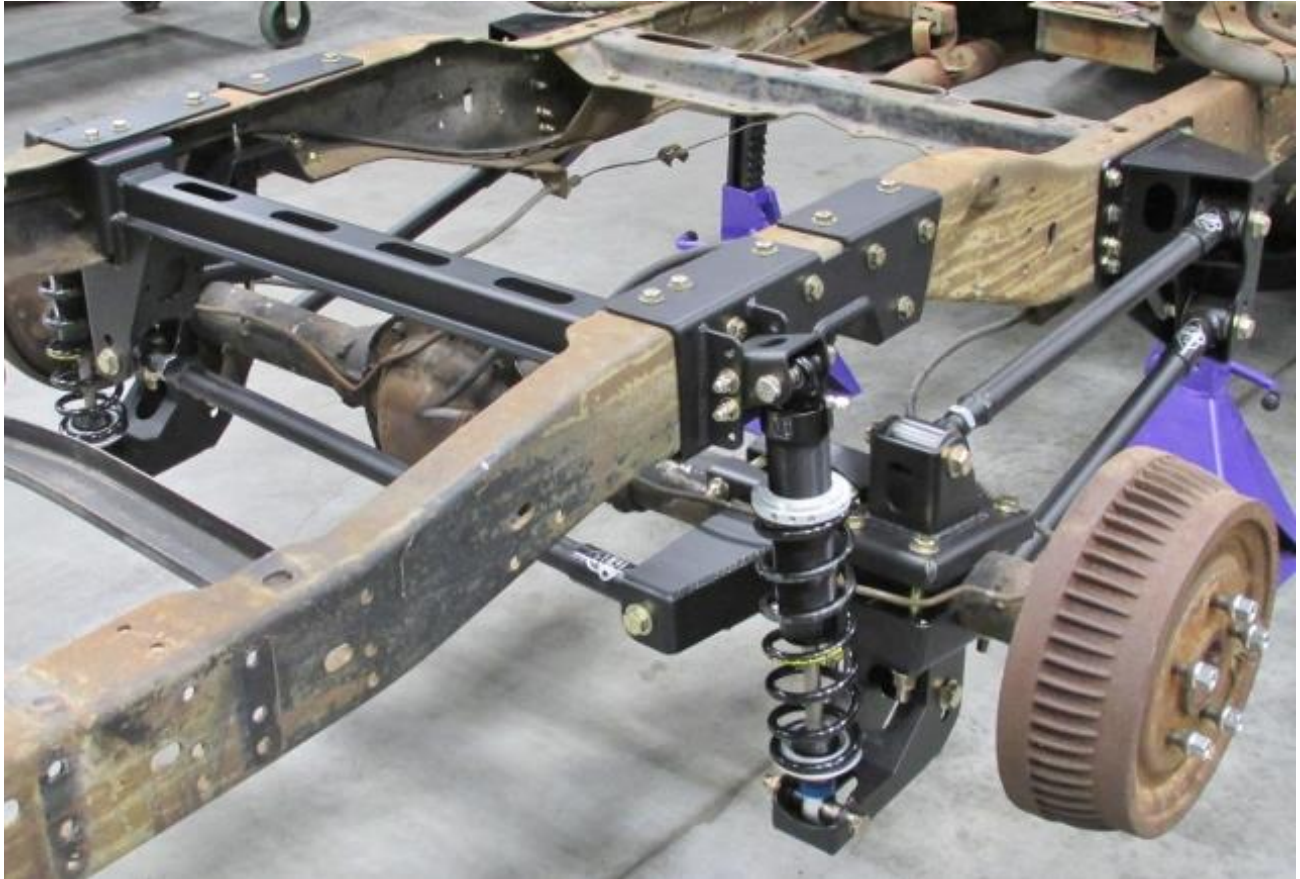

Figure 38 - Final Assembly

51. Raise and lower the vehicle to verify that there is no interference. Now is a good time to re-install the exhaust system if necessary. Re-install the bed. Install the wheels and lower it onto the ground. Verify that the track bar is installed into the hole that places it closest to horizontal (nominal design is the lower hole in the bracket).

52. Confirm the rear axle position again and double check that all of the bolts and jam nuts are tightened to their respective torque specifications.

53. With the vehicle assembled with all the components installed, adjust the ride height as necessary. Detroit Speed does recommends cleaning the threads of the shocks. Once the threads are clean, Detroit Speed recommends applying dry bicycle chain lube to the threads of the shock body before adjusting the spanner nut and compressing the coilover spring. Allow the chain lube to dry before adjusting the spanner nut. If you have the non-adjustable shocks, the spanner nut has a pinch bolt that will need to be tightened before the vehicle is driven.

WARNING: DO NOT ADJUST THE COILOVER ADJUSTING NUT WITHOUT THE VEHICLE RAISED OFF THE GROUND TO REMOVE THE WEIGHT OFF THE COILOVER SHOCKS. FAILURE TO FOLLOW THIS PROCEDURE WILL RESULT IN DAMAGED THREADS ON THE SHOCK BODY THAT CANNOT BE WARRANTIED.

54. Detroit Speed does include a Spanner Tool to adjust ride height however if you have the adjustable coilover shocks, Detroit Speed does offer an Adjustment Tool available as PN: 031061 if needed (Figure 39).



Figure 39 - Adjustable Shock Spanner & Adjustment Tool

55. If the single or the double adjustable remote canister coilover shocks were purchased as an upgrade, refer to the following information for adjustment procedures.

Detroit Speed Single Adjustable Shock Applications

To change from the recommended “Detroit Tuned” valving, adjustments can be made independently to the rebound setting. The rebound is controlled by the knob at the lower shock mount (Shock is mounted body side up). The knob rotates clockwise (+) to increase the damping and counterclockwise (-) to decrease the damping. Refer to Figure 40a.



Figure 40a- Detroit Speed Single Adjustable Shock

To return to the Detroit Speed recommended settings, turn the knob clockwise (+) to full damping. Once at full damping, turn counterclockwise (-) to reach the recommended settings. Refer to Figure 40b for the recommended starting setting.

Rebound (Shaft Knob)..... 20 Open (counterclockwise, -)

Figure 40b - Detroit Speed Recommended

Adjuster Operation

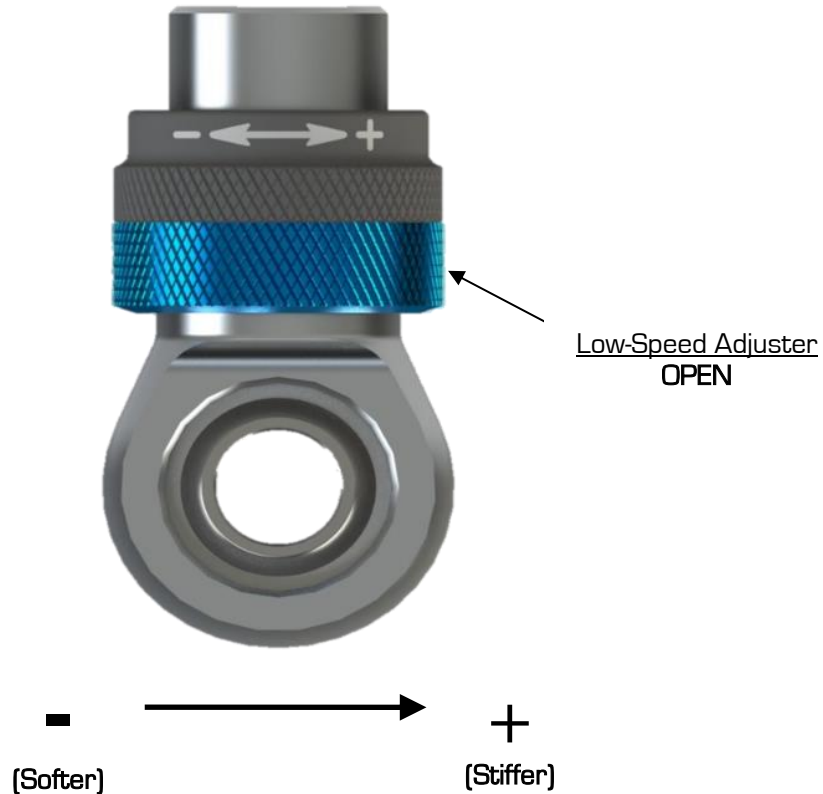

- **Adjuster (60-64 Clicks)**

The low-speed adjuster is a “clicker” style adjuster meaning that its adjustment is measured by detents located inside the blue adjuster knob. There are 16 clicks per 1 revolution of the knob. It uses a right-hand thread in its operation which means as you increase low-speed, the adjuster will move up on the eyelet. The recommended change for an adjustment is 8 clicks at a time. The low-speed adjuster’s reference position is **full stiff** (closed, or all the way up) and referred to -0 (-0 = full stiff, -64 = full soft).

- **Tuning Notes**

- **Racetrack**

- For more grip, soften the damping.
- For increased platform control, stiffen the damping.

- **Street**

- For a more comfortable ride, soften the damping

***DO NOT FORCE KNOB WHEN IT STOPS TURNING, YOU MAY DAMAGE THE ADJUSTER AND INTERNAL HARDWARE**

Detroit Speed Double Adjustable Shocks w/Remote Canisters

To change from the recommended “Detroit Tuned” valving, adjustments can be made independently to both the high and low speed settings. The rebound is controlled by the sweepers at the lower shock mount. The sweepers rotate clockwise (+) to increase the damping and counterclockwise (-) to decrease the damping. Refer to Figure 41a on the next page.

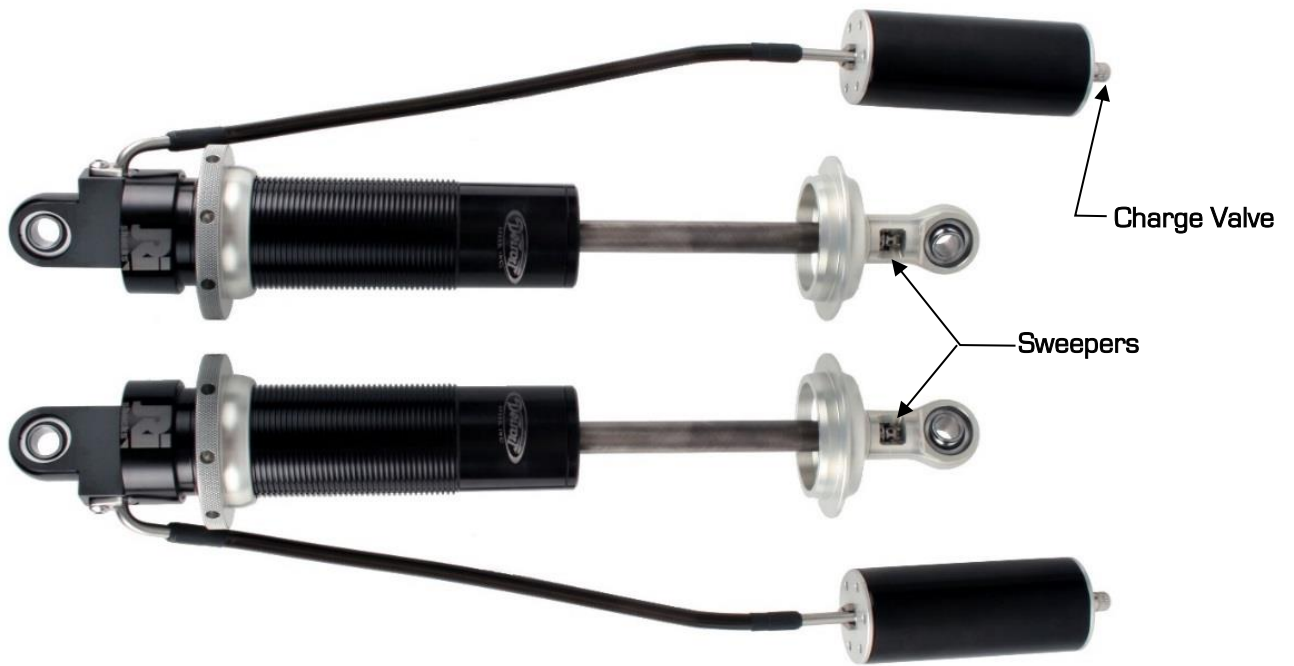

Figure 41a – Detroit Speed Double Adjustable Shock w/ Remote Canister

When adjusting the low speed rebound start at full (+) position, when adjusting the high speed rebound start at full (-) position. To return to the Detroit Speed recommended settings turn the sweeper clockwise (+) to full damping for the low speed setting, and counterclockwise (-) to full damping for the high speed setting. Once at full damping, turn counterclockwise (-) for the low speed setting, and clockwise (+) for the high speed setting to reach the recommended settings. Refer to Figure 41b for recommended starting settings.

Low Speed Rebound (Sweeper)..... 20 sweeps (counterclockwise, -)
 High Speed Rebound (Sweeper)..... 2 sweeps (clockwise, +)

Figure 41b – Detroit Speed Recommended Settings

Adjuster Operation

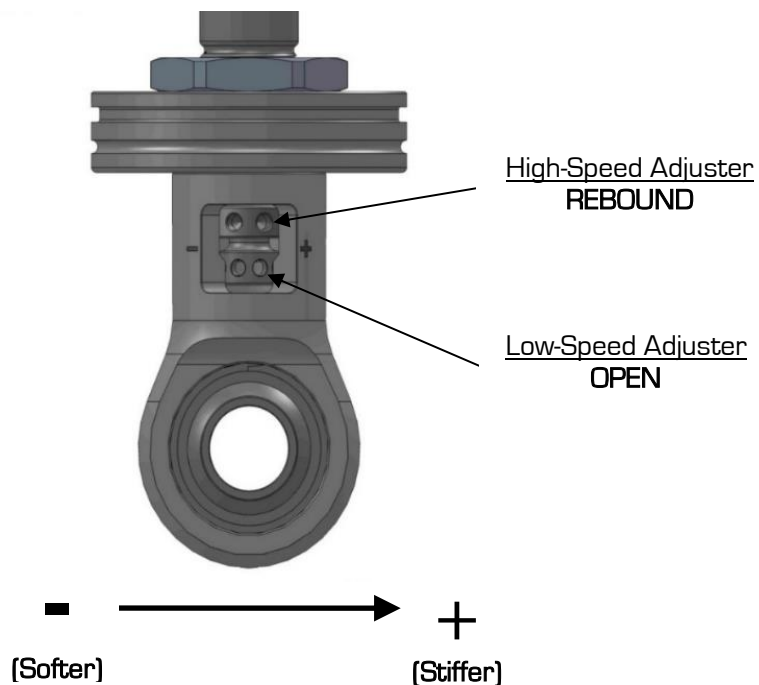

- **High-Speed Adjuster (12 Sweeps)**

The high-speed adjuster is a “sweep” style adjuster meaning that its adjustment is measured by the location of the adjuster in the eyelet window. It uses a left-hand thread in its operation which means; as you increase high-speed, the adjuster will move down in the window*. The high-speed adjuster’s reference position is **full soft** and referred to as +0 (+0 = full soft, +12 = full stiff).

- **Low-Speed Adjuster (25 Clicks)**

The low-speed adjuster is a “clicker” style adjuster meaning that its adjustment is measured by detent grooves located inside the high-speed shaft. It uses a right-hand thread in its operation which means; as you increase low-speed, the adjuster will move up in the window. The low-speed adjuster’s reference position is **full stiff** and referred to -0 (-0 = full stiff, -25 = full soft).

**The low-speed adjustment does not change when adjusting the high-speed.*

To aid in the installation of the reservoirs, we also offer a set of Billet Aluminum Remote Canister Mounts. The canister mounts are available exclusively through Detroit Speed, PN: 032102. They are shown below in Figure 42.



Figure 42 - Billet Aluminum Remote Canister Mounts

If you have any questions before or during the installation of this product please contact Detroit Speed Inc. at tech@detroitsspeed.com or 704.662.3272

Legal Disclaimer: *Detroit Speed, Inc. is not liable for personal, property, legal, or financial damages from the use or misuse of any product we sell. The purchaser is solely responsible for the safety and performance of these products. No warranty is expressed or implied.*



**1973-87 GM SQUARE BODY TRUCK
QUADRA-LINK AXLE BRACKET LOCATIONS**

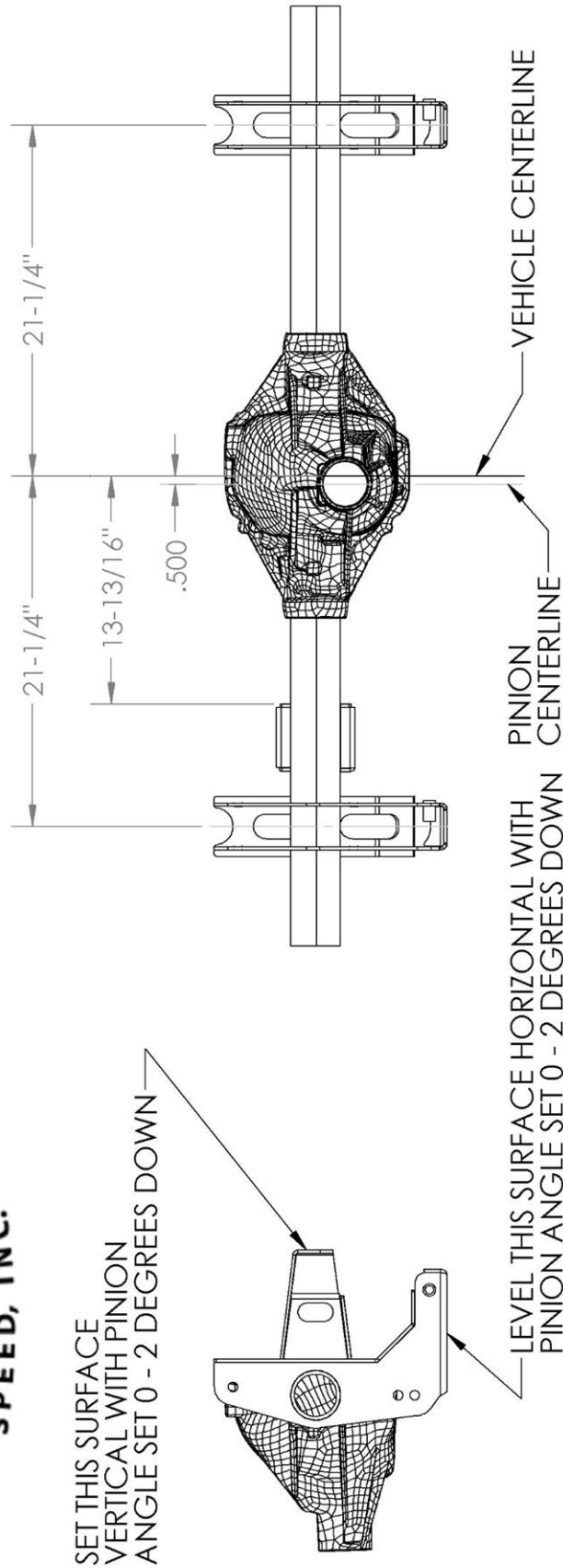

**INSERT 2.450" LONG WELD SPACERS INTO LINK MOUNTING LOCATIONS
BEFORE WELDING BRACKETS TO THE AXLE HOUSING**

***NOTE THAT THE CENTERLINE OF THE AXLE IS NOT LOCATED AT THE CENTER OF THE PINION, AND DEPENDING ON AXLE TYPE, MAY NOT BE LOCATED AT THE CENTER OF THE CARRIER HOUSING. THE PINION IS OFFSET TO THE PASSENGER SIDE OF THE VEHICLE. DETROIT SPEED USES 1/2" OFFSET. DIMENSIONS SHOWN HERE ARE SYMMETRIC ABOUT AXLE/CAR CENTERLINE.**

Figure 43 - Axle Bracket Location

Once again, we appreciate your business.

If you have any questions during the installation of this product, call (704) 662-3272



Detroit Speed, Inc.
Swivel-Links

WARNING:

There can be no more than 2" of exposed threads on the end link (3/4" of thread engagement in the tube). This measurement does include the jam nut (see below).

