

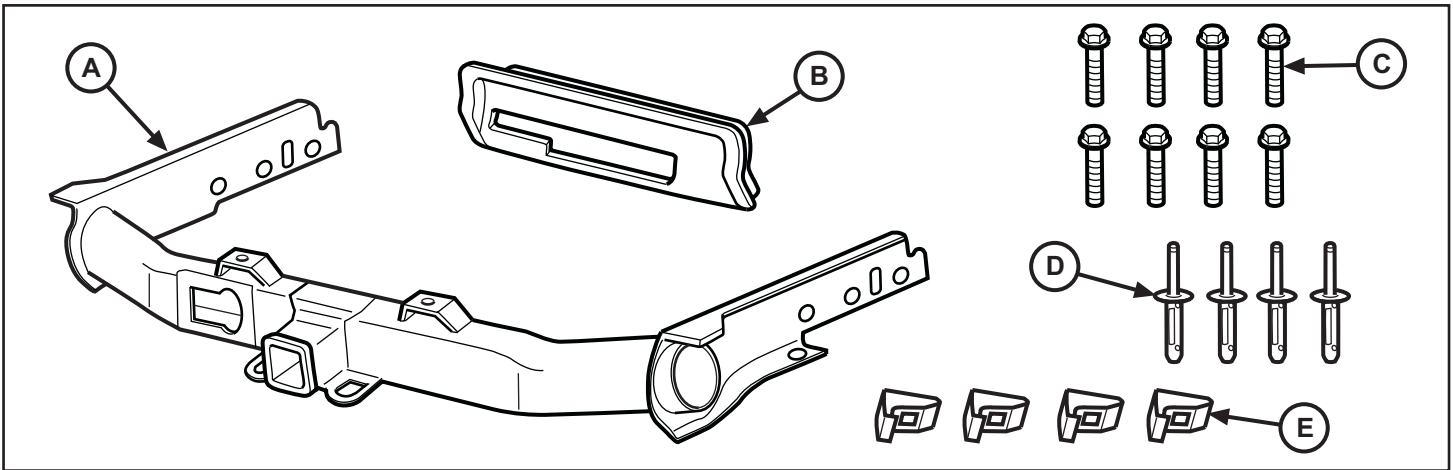

Trailer Hitch

JEEP GRAND CHEROKEE
DODGE DURANGO



CALL OUT	DESCRIPTION	QUANTITY
A	Hitch Assembly	1
B	Bezel	1
C	21mm Flange Bolts	8
D	Pop Rivets	4
E	Spring Clips	4

TRAILER HITCH

1. Remove rear fascia. Save all fasteners for reattachment except pop rivets from fender strips.

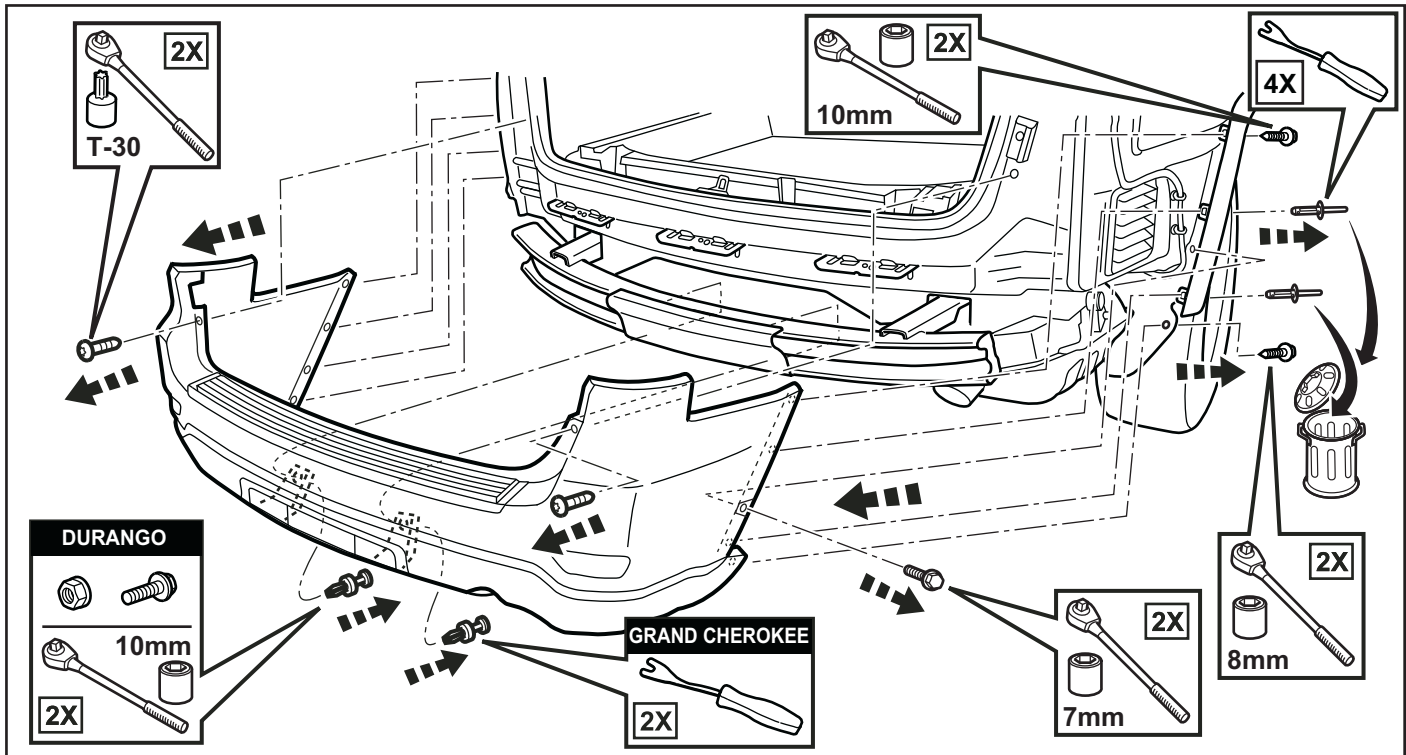

2. Unbolt and remove existing crossmember. Discard crossmember and all fasteners.

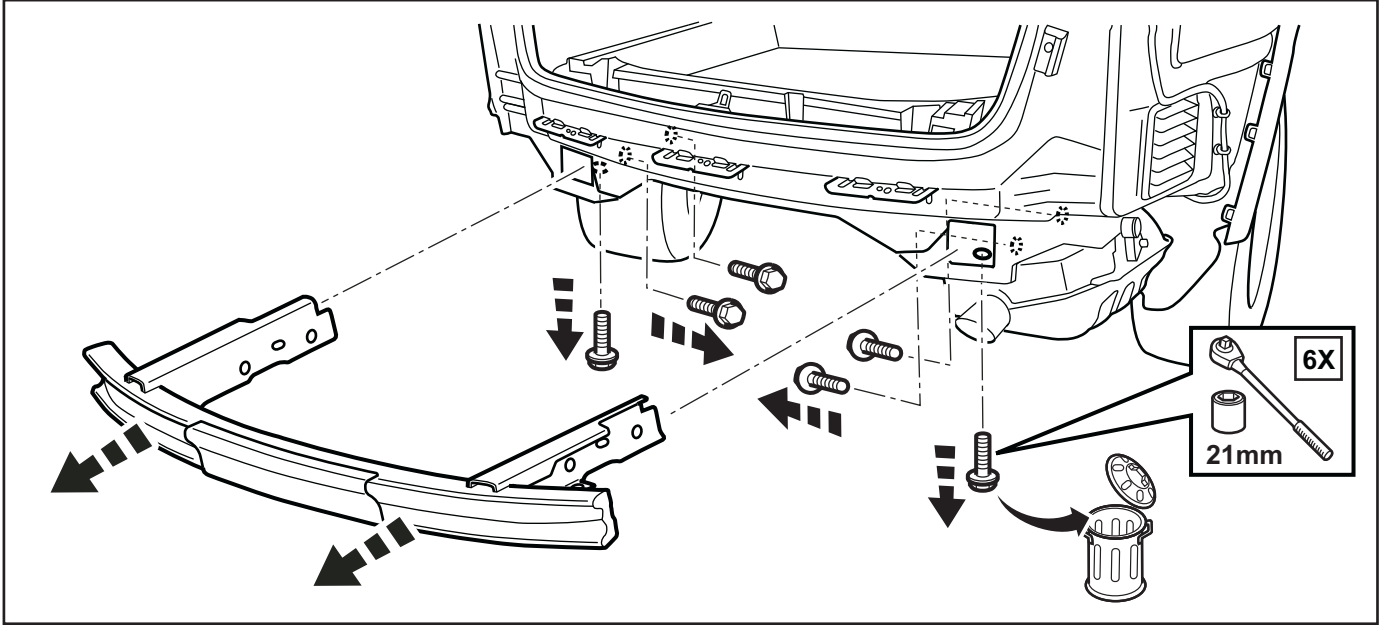

3. Place rear fascia face down on support buck. Rub area with white chalk to highlight the scribed rectangle and slots indicated on inside lower surface of bumper.

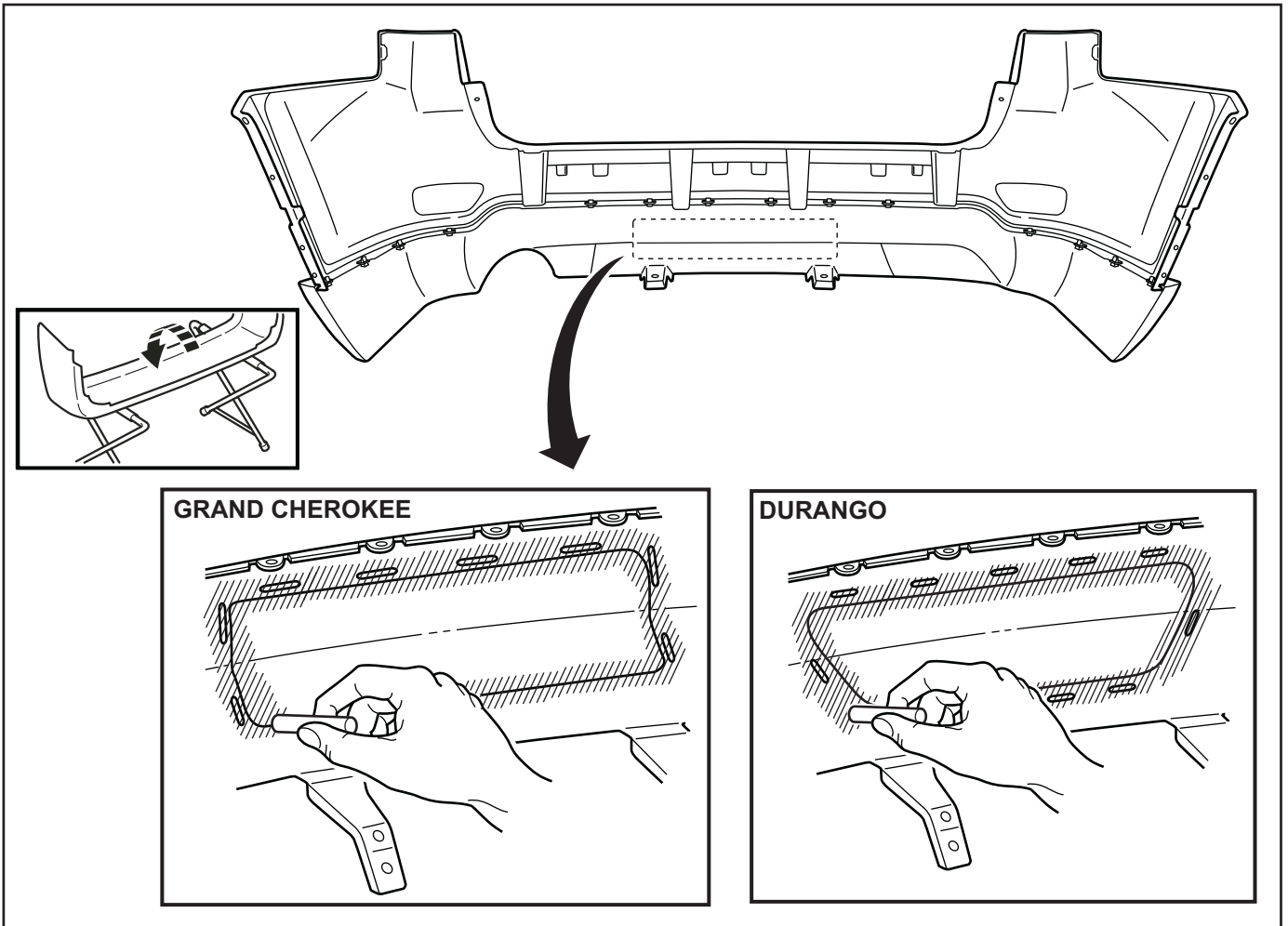

GRAND CHEROKEE

4. Drill starter holes for tab openings according to scribed areas as shown. Use a 1/8" (3.4mm) bit for the top six slots and a 3/32" (2.3mm) bit for lowest two slots. Be sure to drill both ends of the slots.

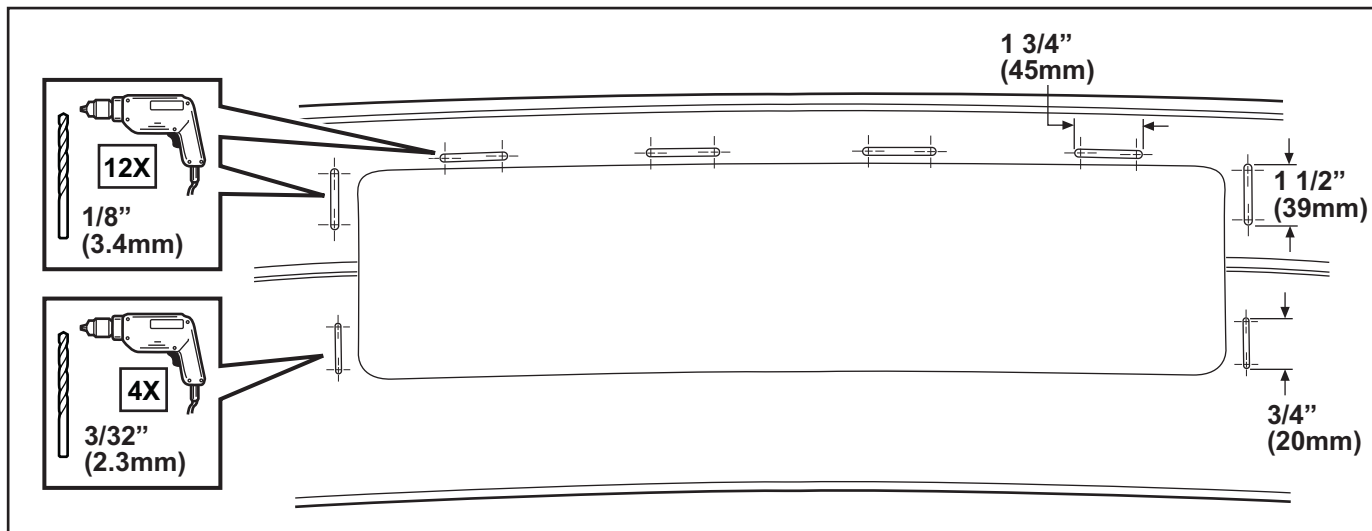

5. Cut through remaining areas of tab openings with a utility knife according to scribed areas as shown. Discard cut out portions.

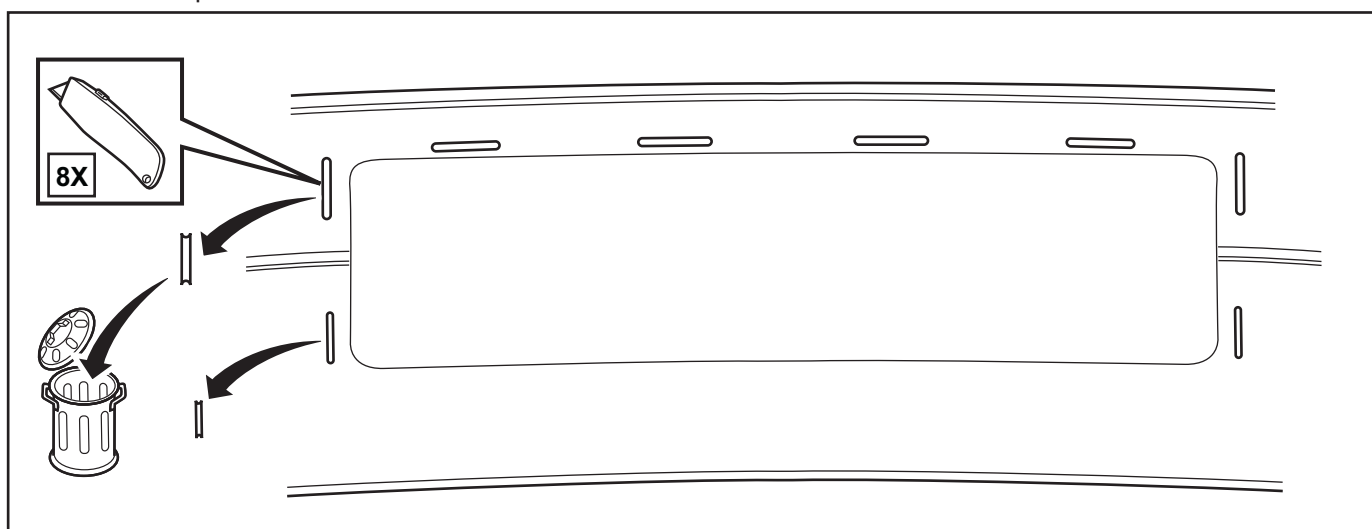

6. Cut out center bezel opening according to scribed areas as shown. Discard cut out portion.

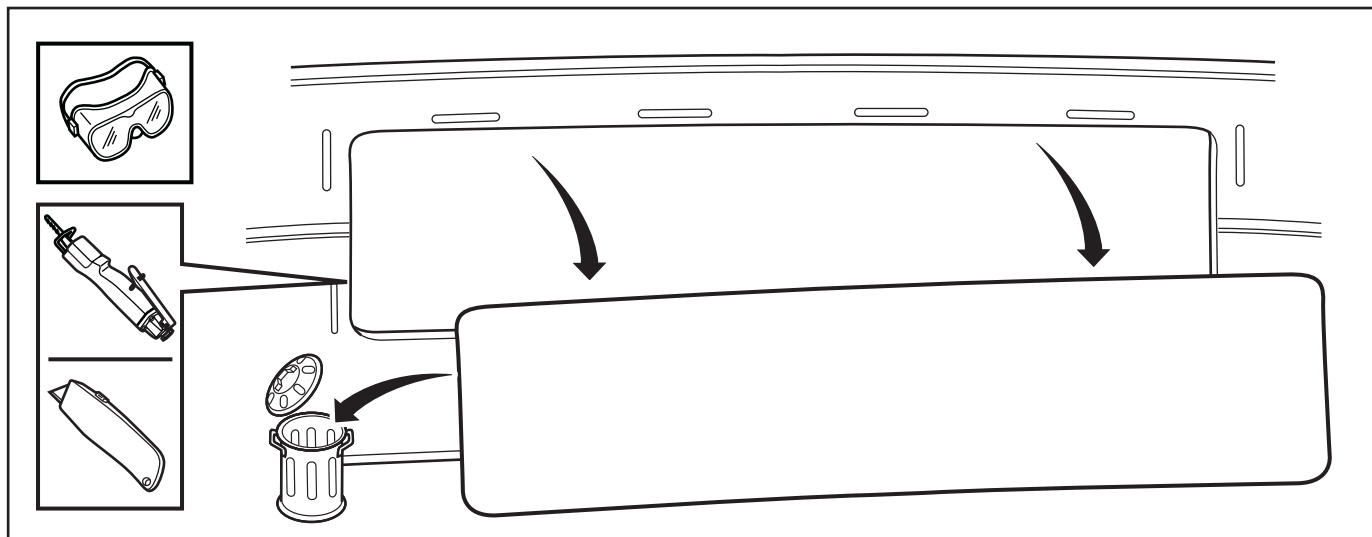

DURANGO

7. Drill starter holes for tab openings according to scribed areas as shown. Use a 3/32" (2.9mm) bit for the top five slots, a 3/16" (4.6mm) bit for the lowest four slots and a 1/8" (3.5mm) bit for the two side slots. Be sure to drill both ends of the slots.

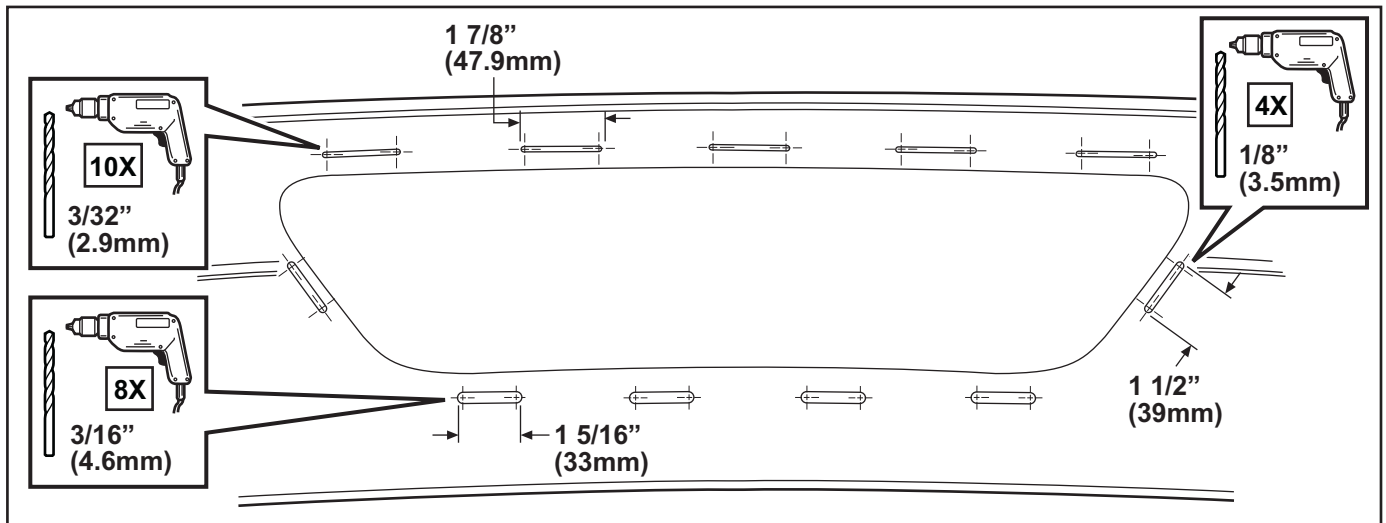

8. Cut through remaining areas of tab openings with a utility knife according to scribed areas as shown. Discard cut out portions.

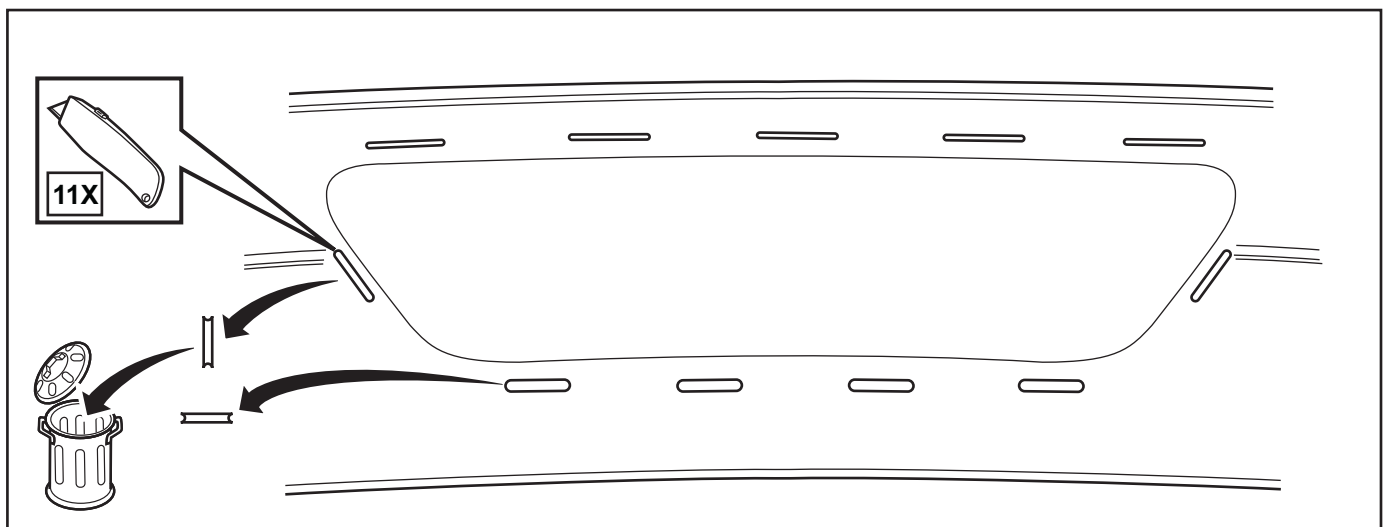

9. Cut out center bezel opening according to scribed areas as shown. Discard cut out portion.

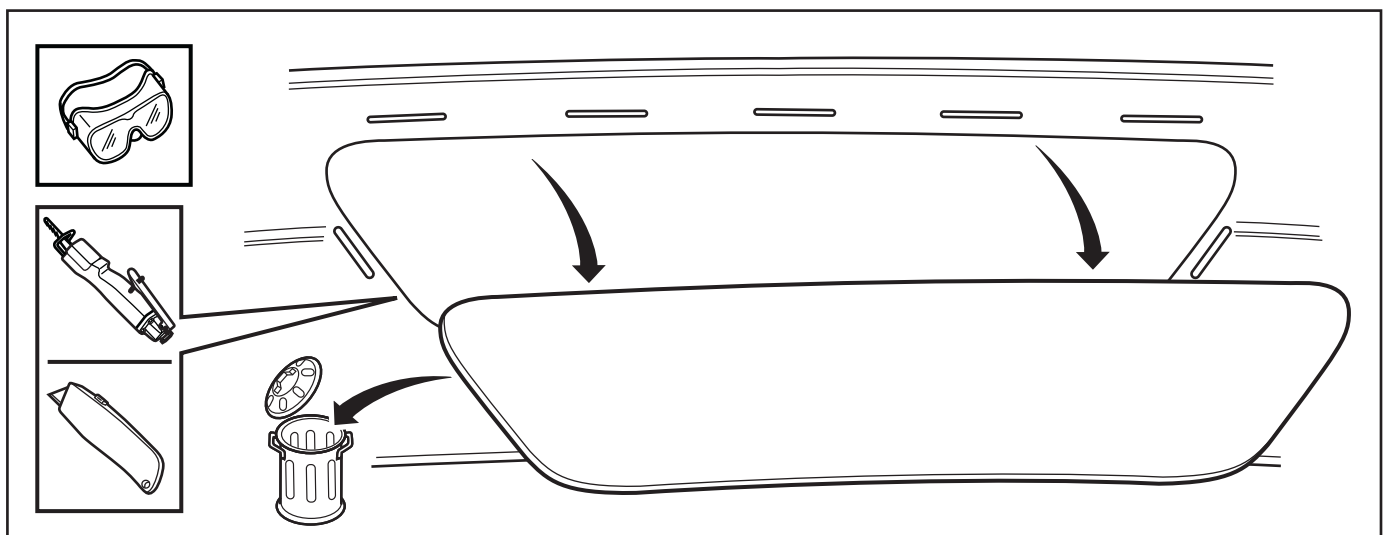

10. Press bezel into bumper opening. Be sure all tabs are firmly pressed in and secure with (2) spring clips as shown.

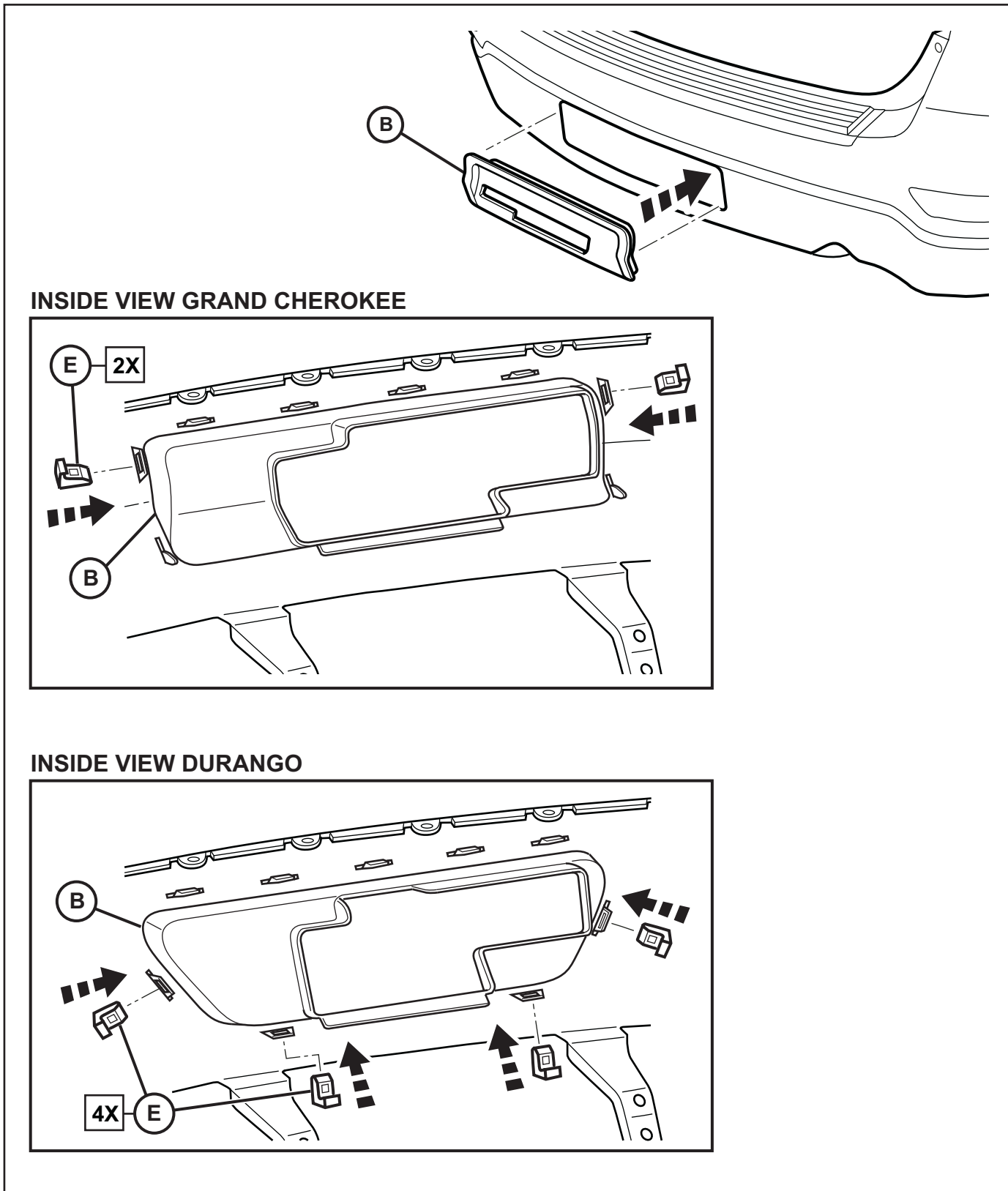

11. Using (8) 21mm bolts provided with the kit, install new hitch assembly. Tighten (8) bolts to 165 Nm (122 ft. lbs.)

NOTE: Removal of crossmember in step 2 involved (6) bolts. Installation of trailer hitch requires (8) bolts.

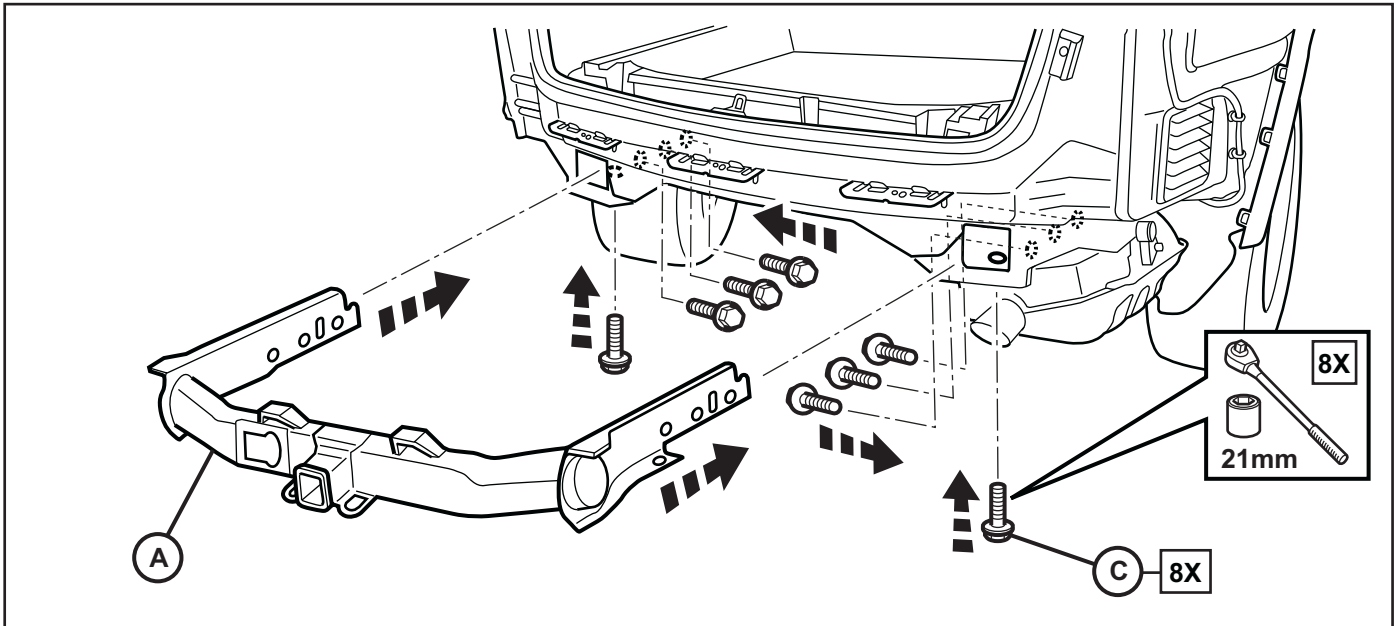

12. Re-install rear fascia.

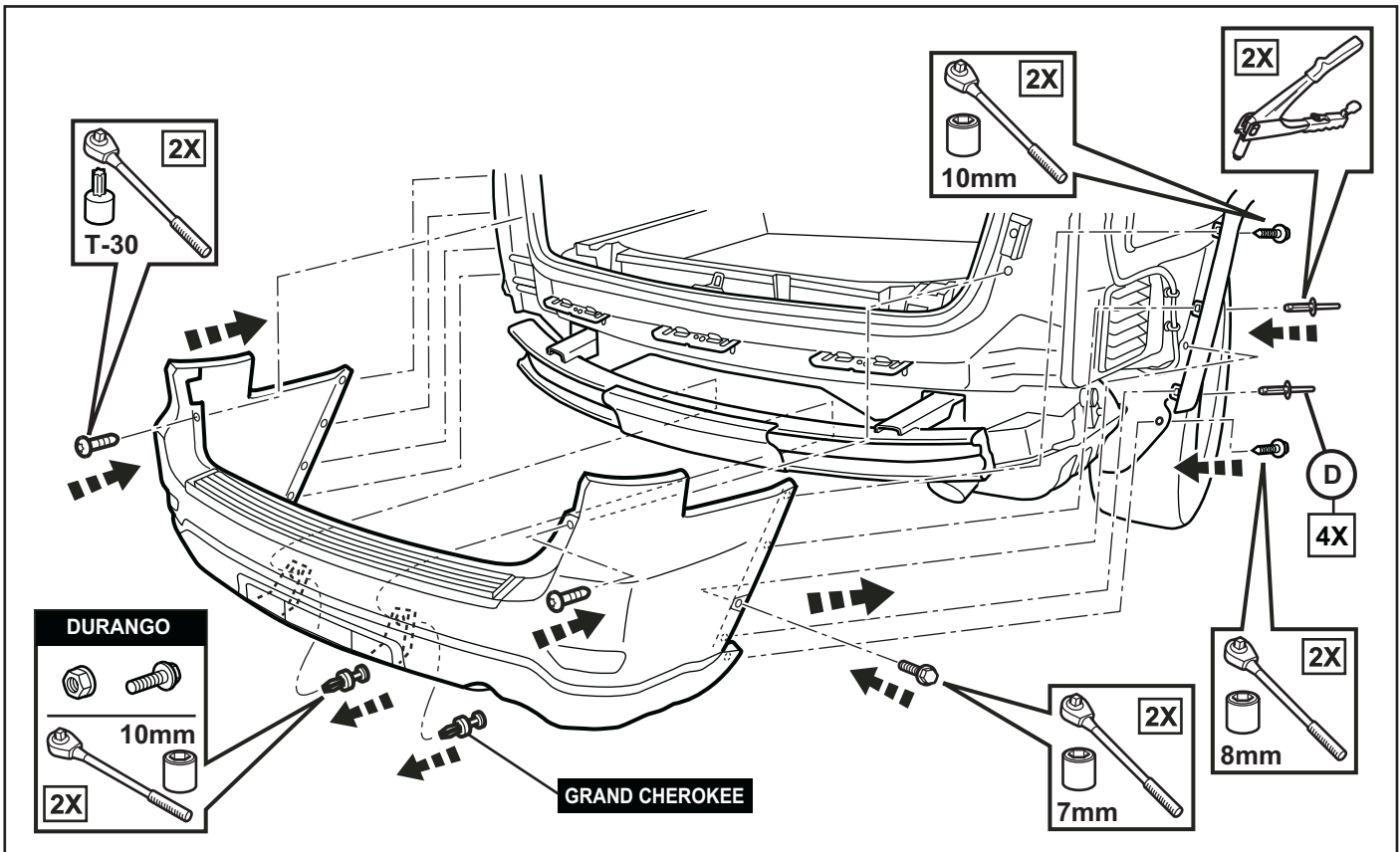



ATTELAGE DE REMORQUE

JEEP GRAND CHEROKEE
DODGE DURANGO

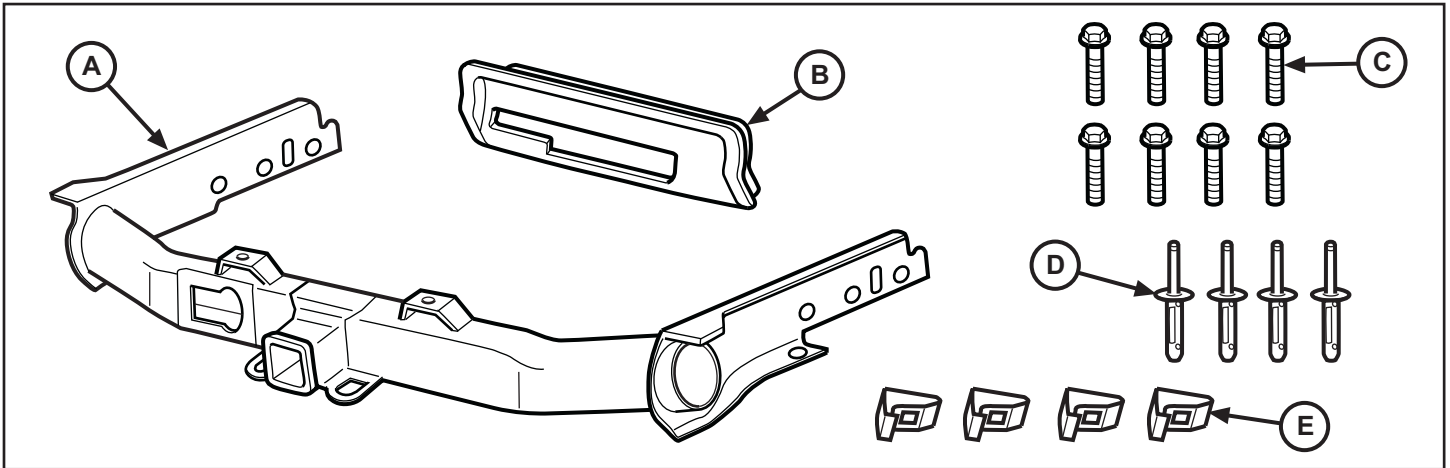

CALL OUT	DESCRIPTION	QUANTITÉ
A	Pièces d'attelage	1
B	Cercle enjoliveur	1
C	Boulons à tête bridée de 21 mm	8
D	Rivet pop	4
E	Serres à ressort	4

ATTELAGE DE REMORQUE

1. Déposer le carénage et sauvegarder toutes les attaches pour la repose. Jeter rivets pop à partir de bandes pare-chocs.

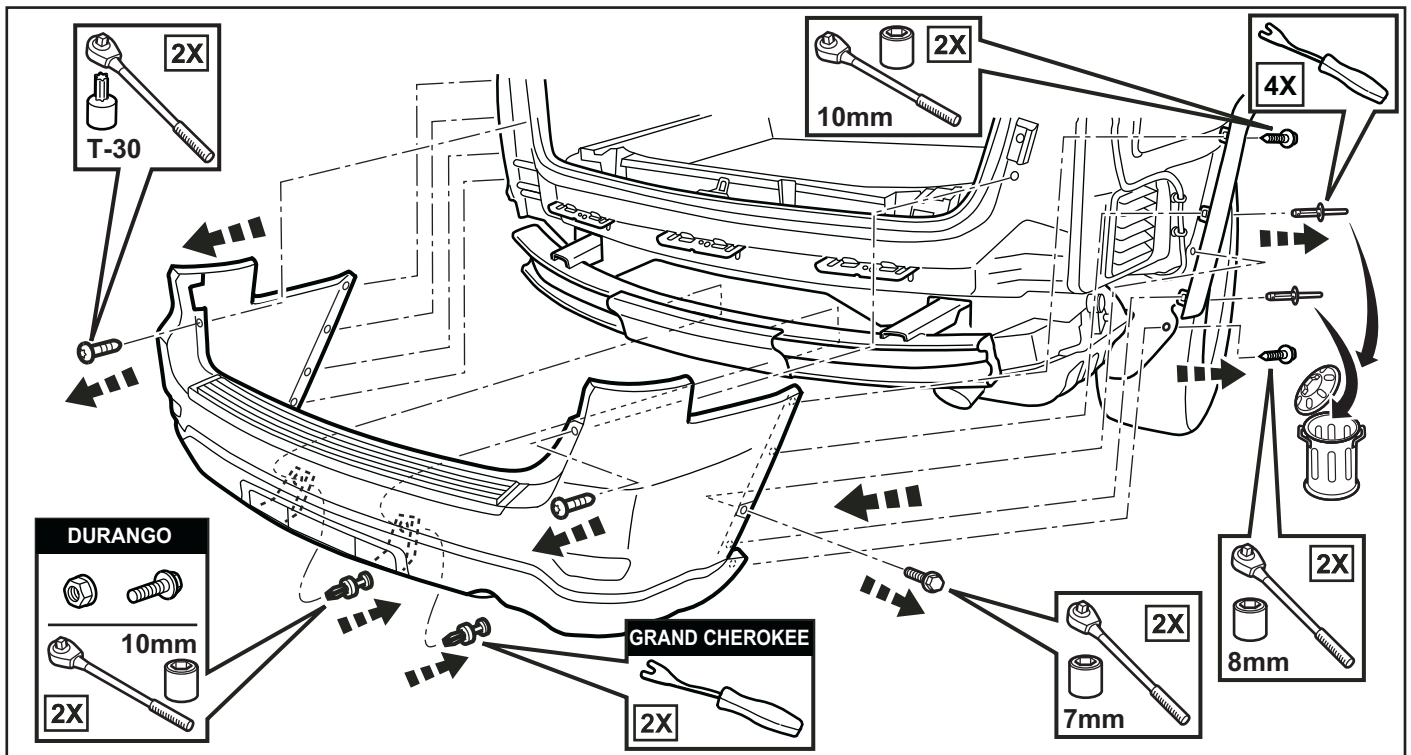

2. Déboulonner et déposer le support transversal et mettez-le au rebut ainsi que toute la quincaillerie de fixation.

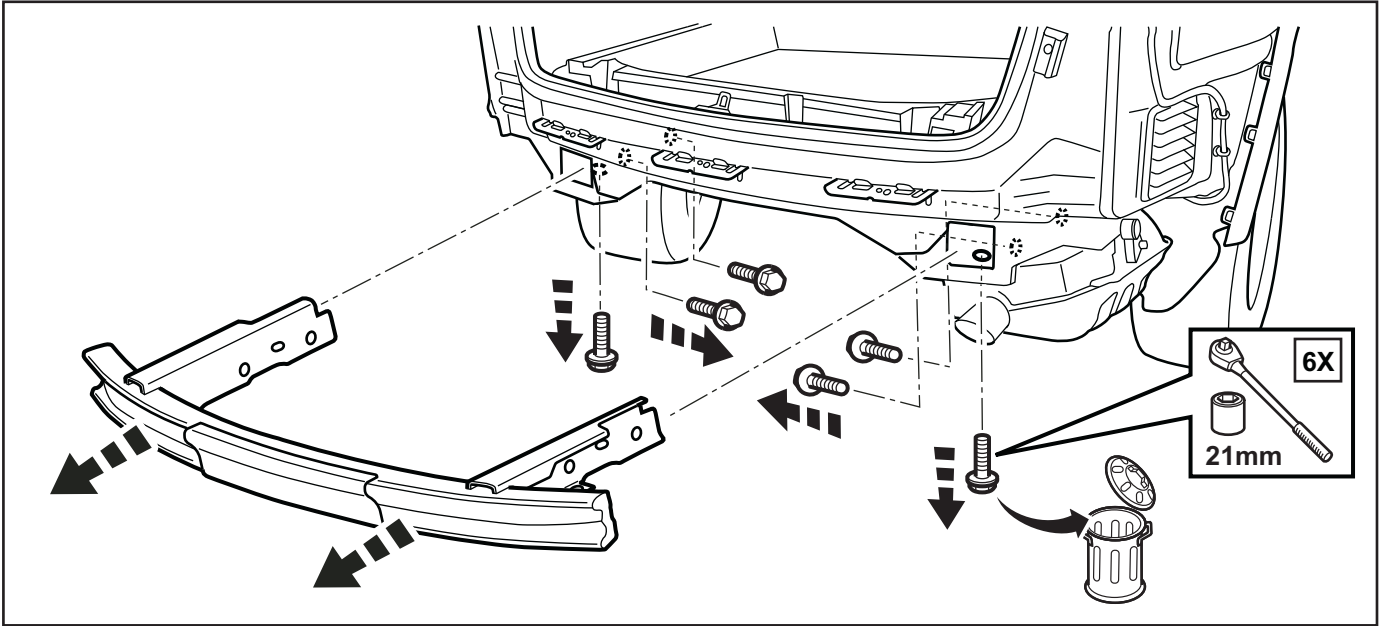

3. Placer le carénage arrière sur un chevalet et blanchir de craie le rectangle et fentes marquées à l'intérieur de la surface du bas du pare-chocs.

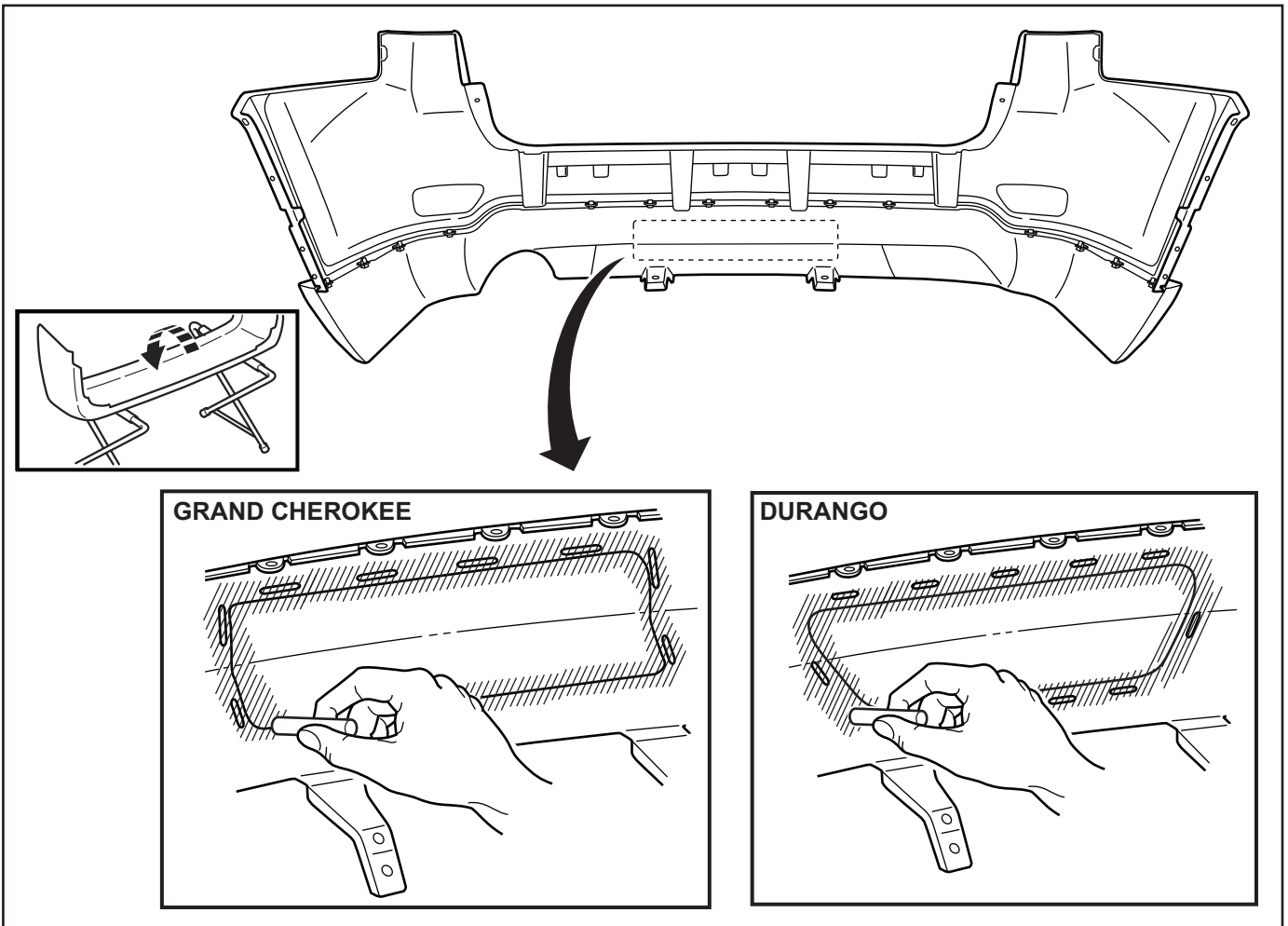

GRAND CHEROKEE

4. Percer des trous de départ des fentes d'ouverture marquées comme montré au dessin. Pour les six fentes du haut, utiliser un foret de 1/8 po (3,4 mm) et un foret de 3/32 po (2,3 mm) pour les deux fentes inférieures. Assurez-vous de percer un trou à chacune des extrémités des fentes.

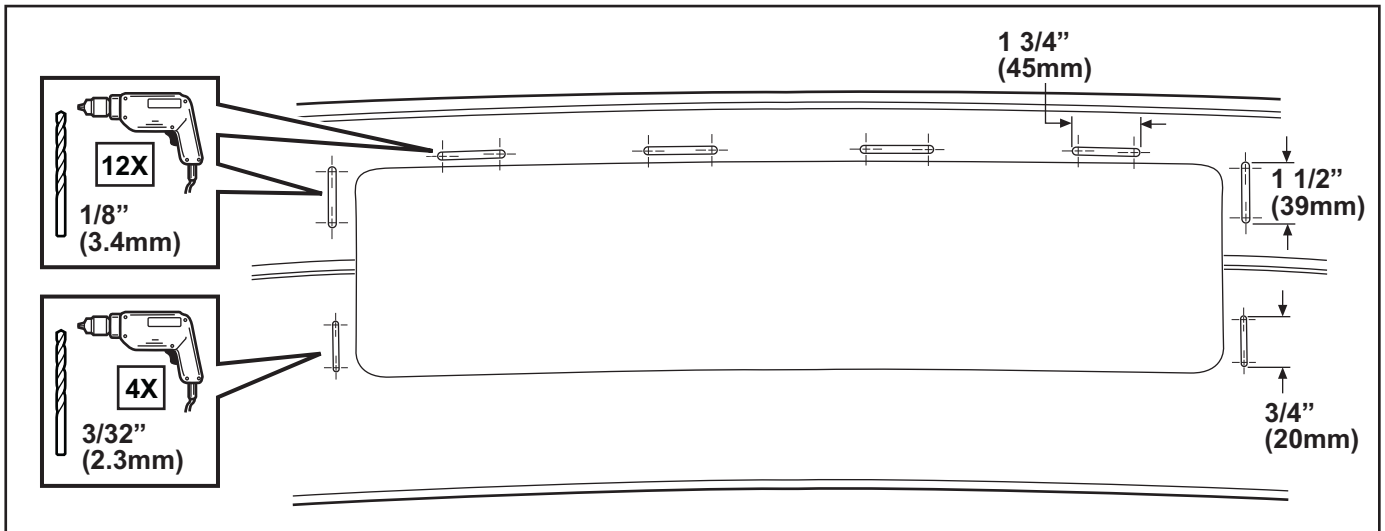

5. À l'aide d'une lame ou couteau tout usage, découper le reste des fentes comme montré au dessin et mettez au rebut les sections retirées.

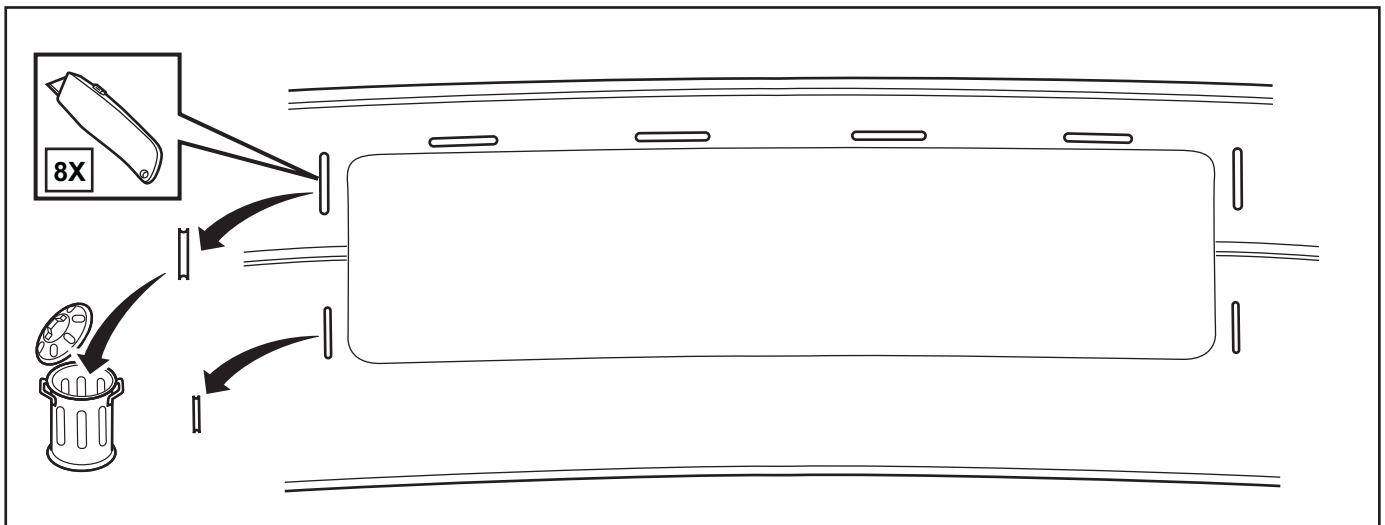

6. Découper l'ouverture circulaire centrale de la région marquée comme montré au dessin et mettez au rebut la section retirée.

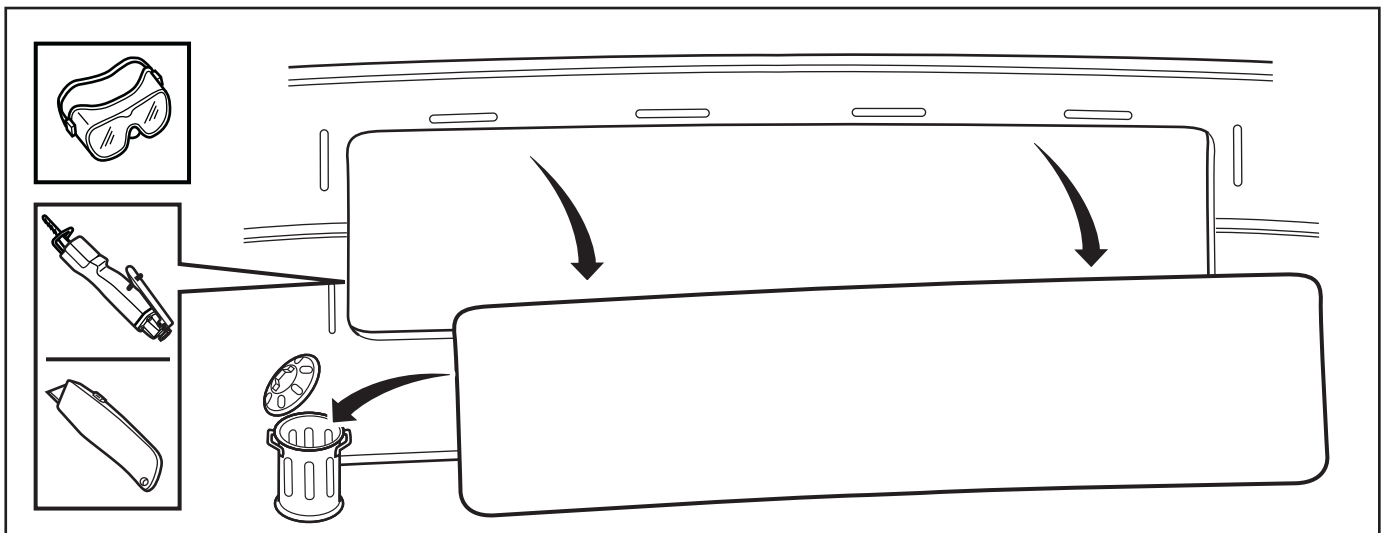

DURANGO

7. Percer des trous de départ des fentes d'ouverture marquées comme montré au dessin. Pour les five fentes du haut, utiliser un foret de 3/32 po (2.9 mm) et un foret de 3/16 po (4.6 mm) pour les quatre fentes inférieures. Pour les deux fentes latérales utiliser une perceuse 1/8 po (3.5 mm). Assurez-vous de percer un trou à chacune des extrémités des fentes.

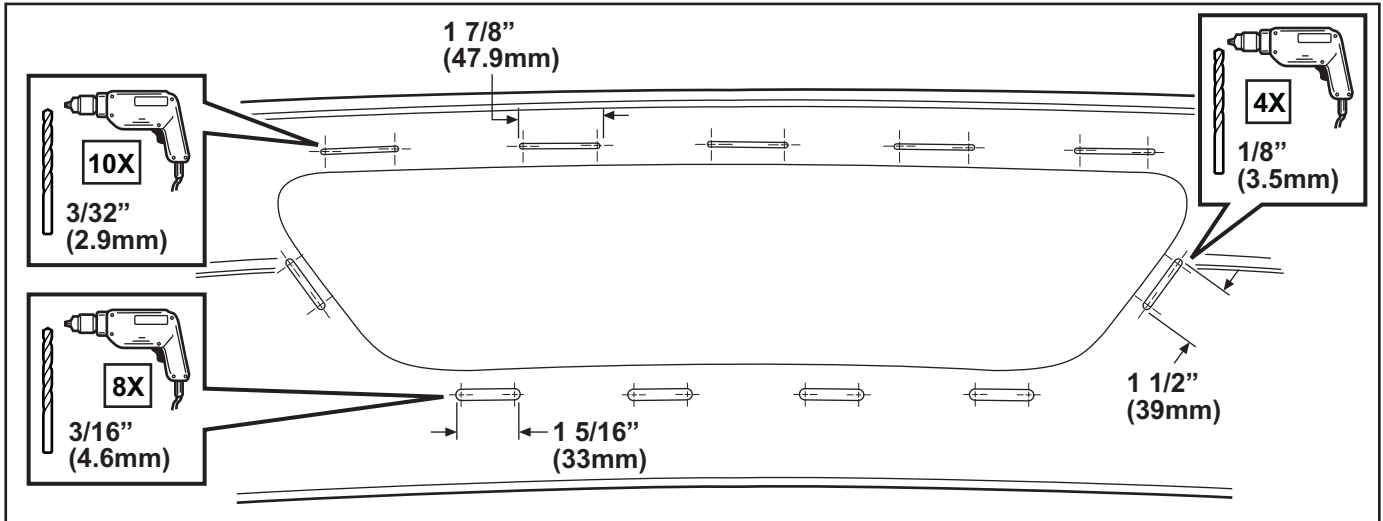

8. À l'aide d'une lame ou couteau tout usage, découper le reste des fentes comme montré au dessin et mettez au rebut les sections retirées.

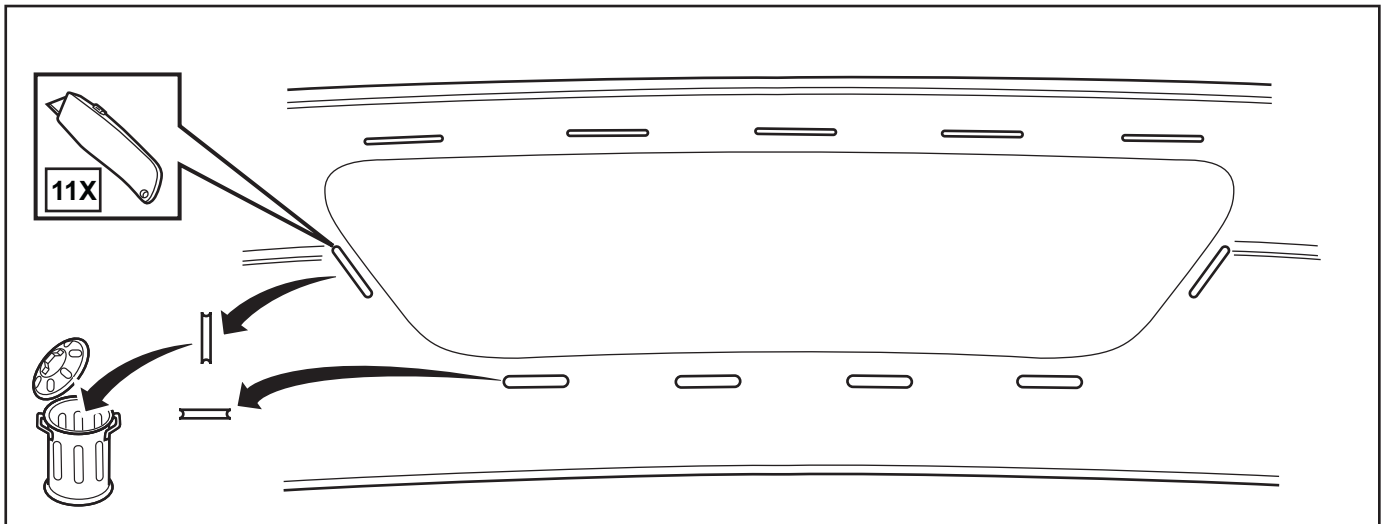

9. Découper l'ouverture circulaire centrale de la région marquée comme montré au dessin et mettez au rebut la section retirée.

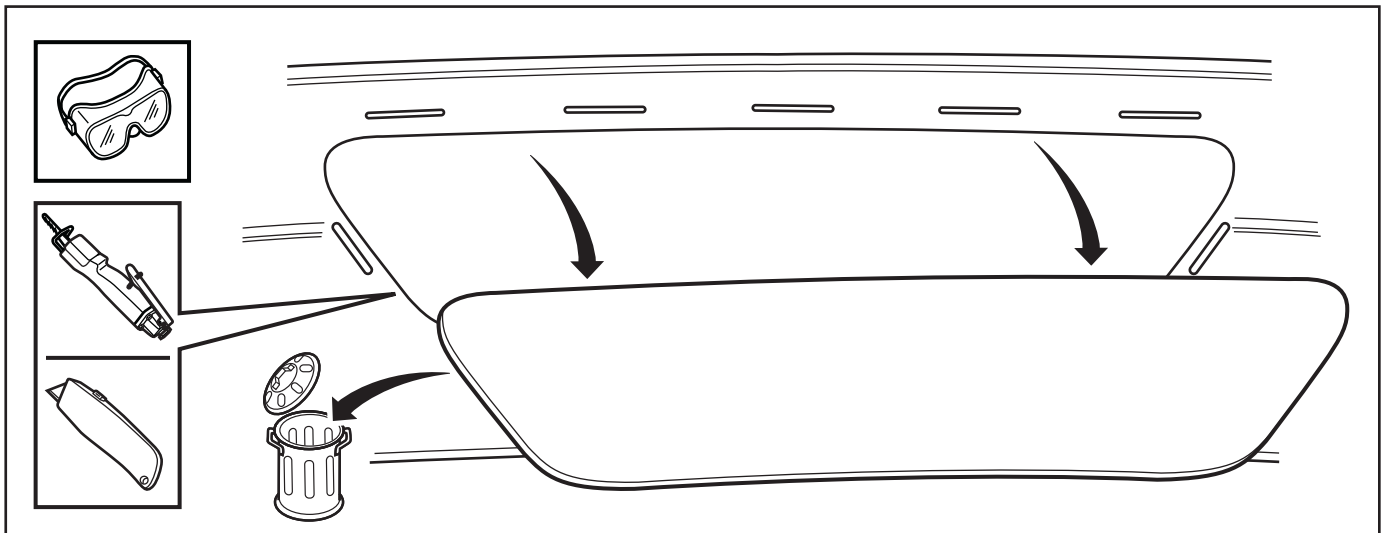

10. Insérez par pression le cercle enjoliveur dans l'ouverture du pare-chocs en vous assurant que toutes les languettes sont bien insérées et retenues avec deux (2) serres à ressort comme montré.

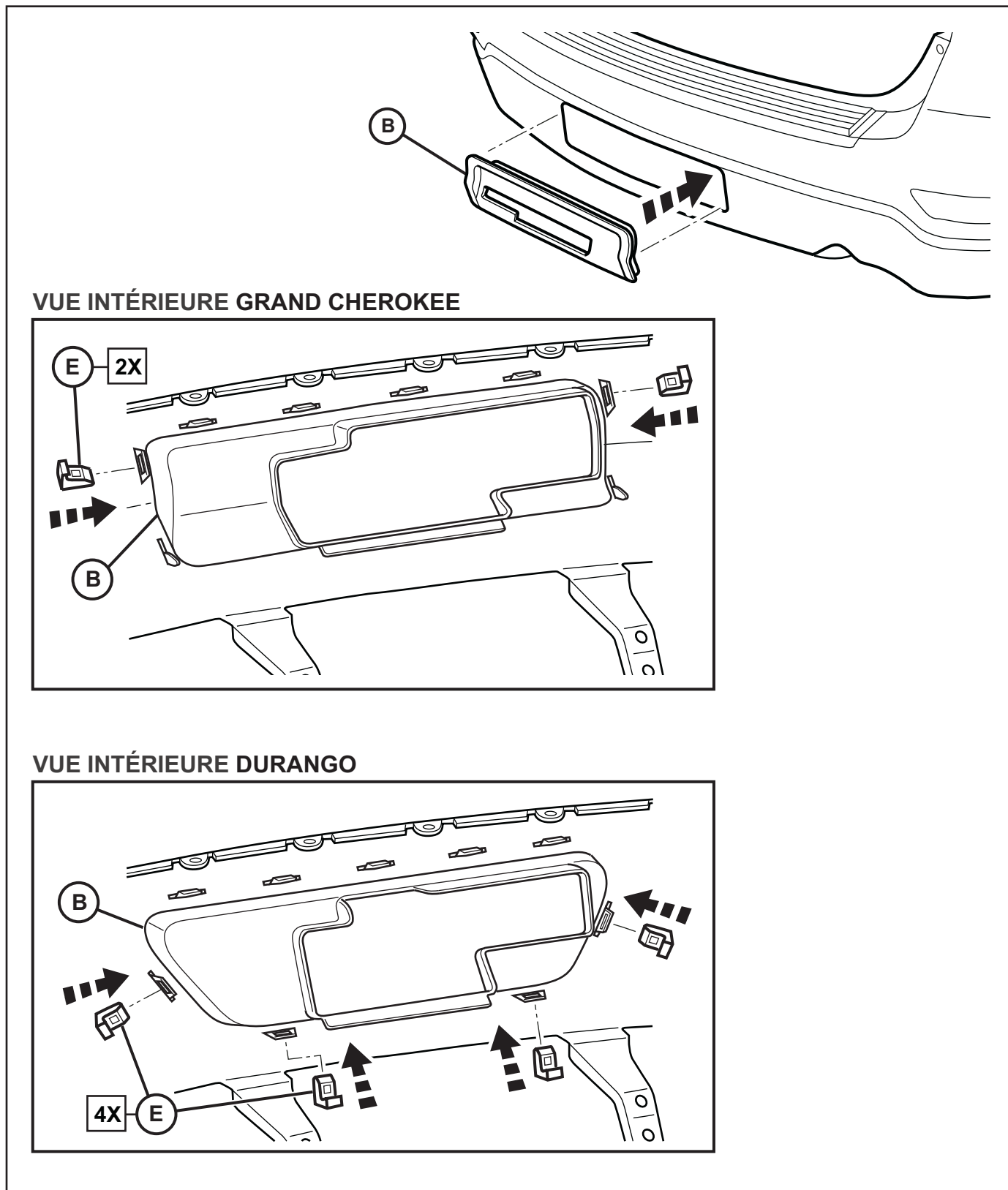

11. Installer l'assemblage du nouvel attelage à l'aide des huit (8) boulons de 21 mm inclus dans le matériel de l'ensemble et serrez les huit boulons au couple de 165 N-m (122 lb-pi)

REMARQUE : La dépose du support transversal de l'étape 2 impliquait six (6) boulons et l'installation de l'attelage de remorque nécessite huit (8) boulons.

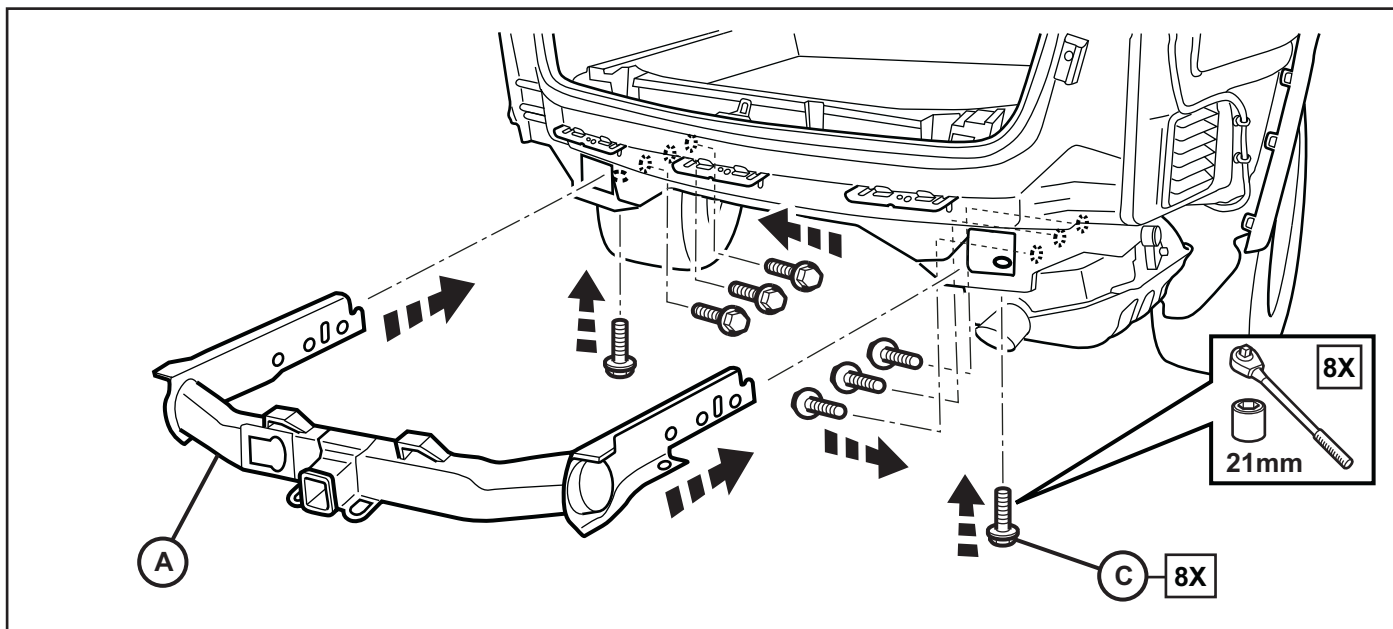

12. Reposer le carénage arrière.

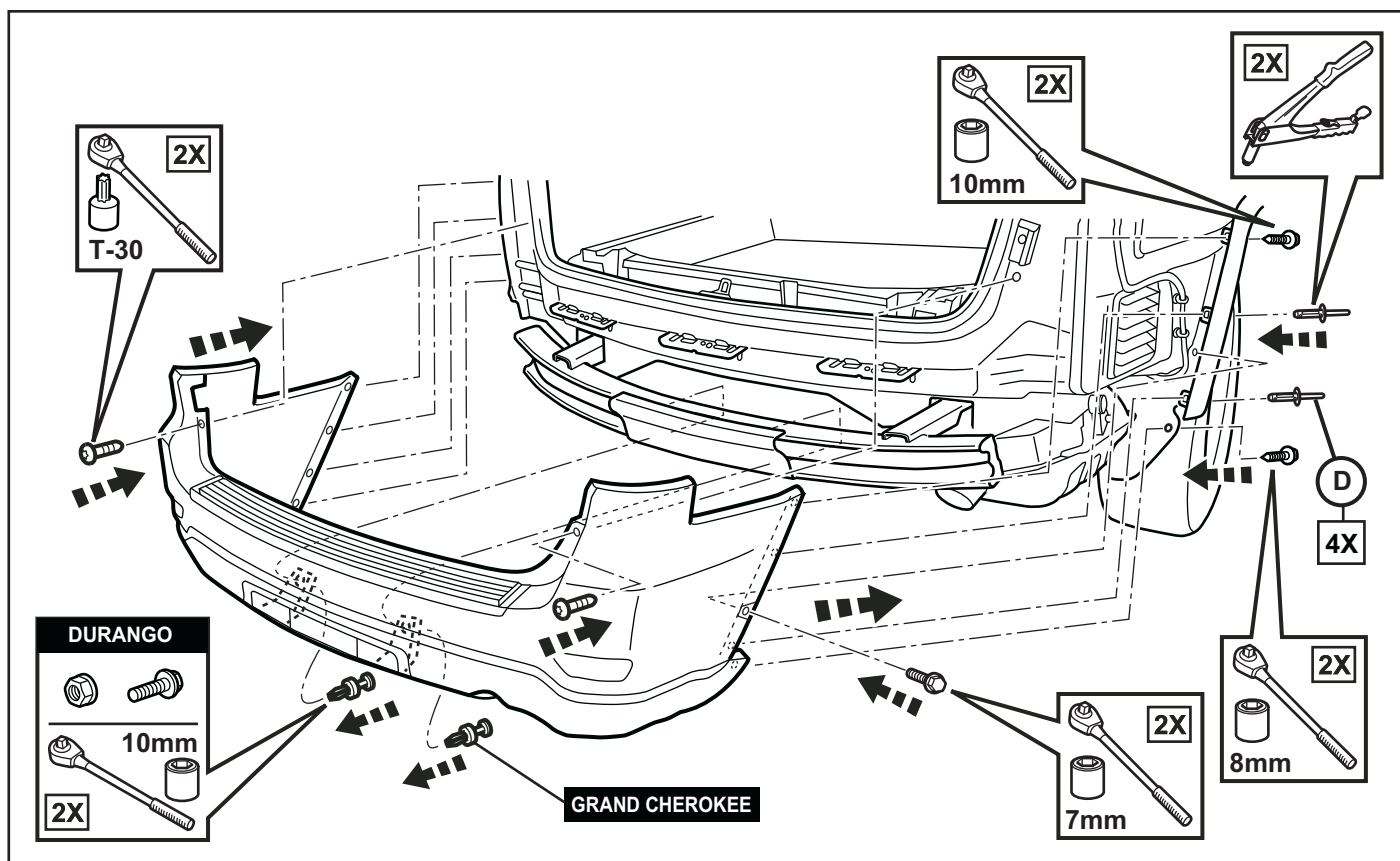



ENGANCHE PARA REMOLQUE

JEEP GRAND CHEROKEE
DODGE DURANGO

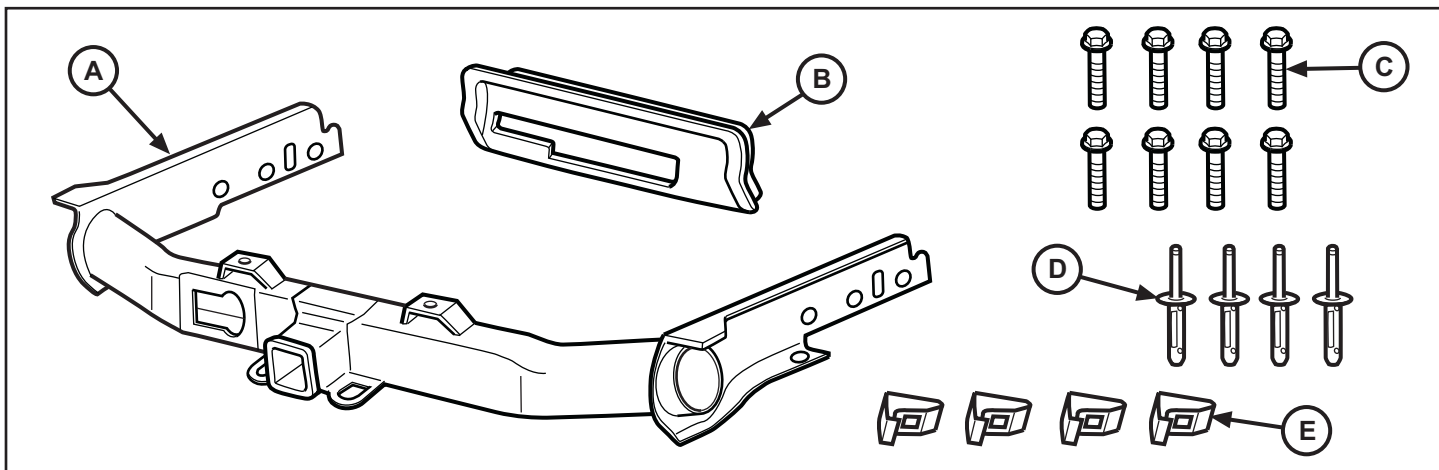

ELEMENTO	DESCRIPCIÓN	CANTIDAD
A	Conjunto del enganche	1
B	Bisel	1
C	Pernos embridados de 21mm	8
D	Remache pop	4
E	Broches de resorte	4

ENGANCHE PARA REMOLQUE

1. Desmonte la facia trasera. Conserve todos los sujetadores para volver a fijar. Deseche los remaches pop de las tiras de defensa.

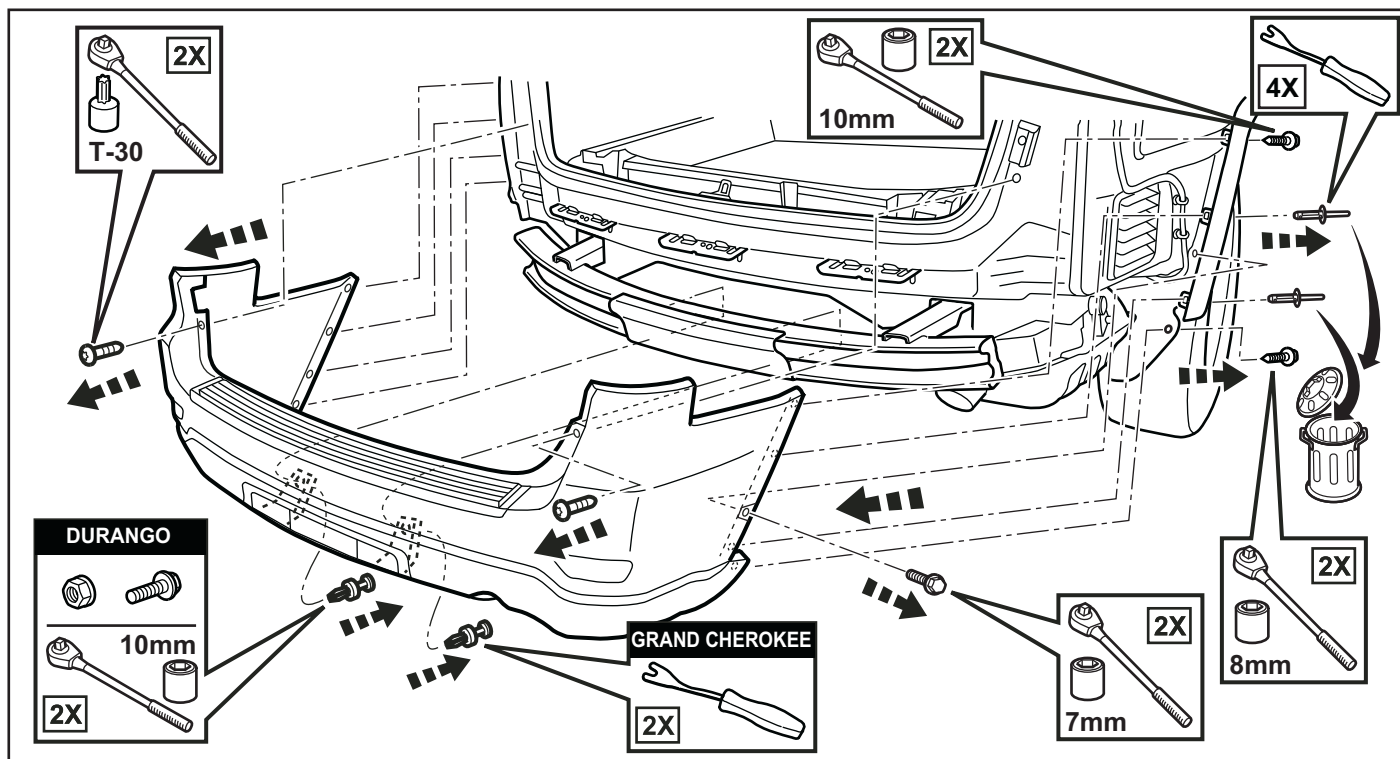

- 2. Destornille y desmonte el travesaño existente. Deseche el travesaño y todos los sujetadores.

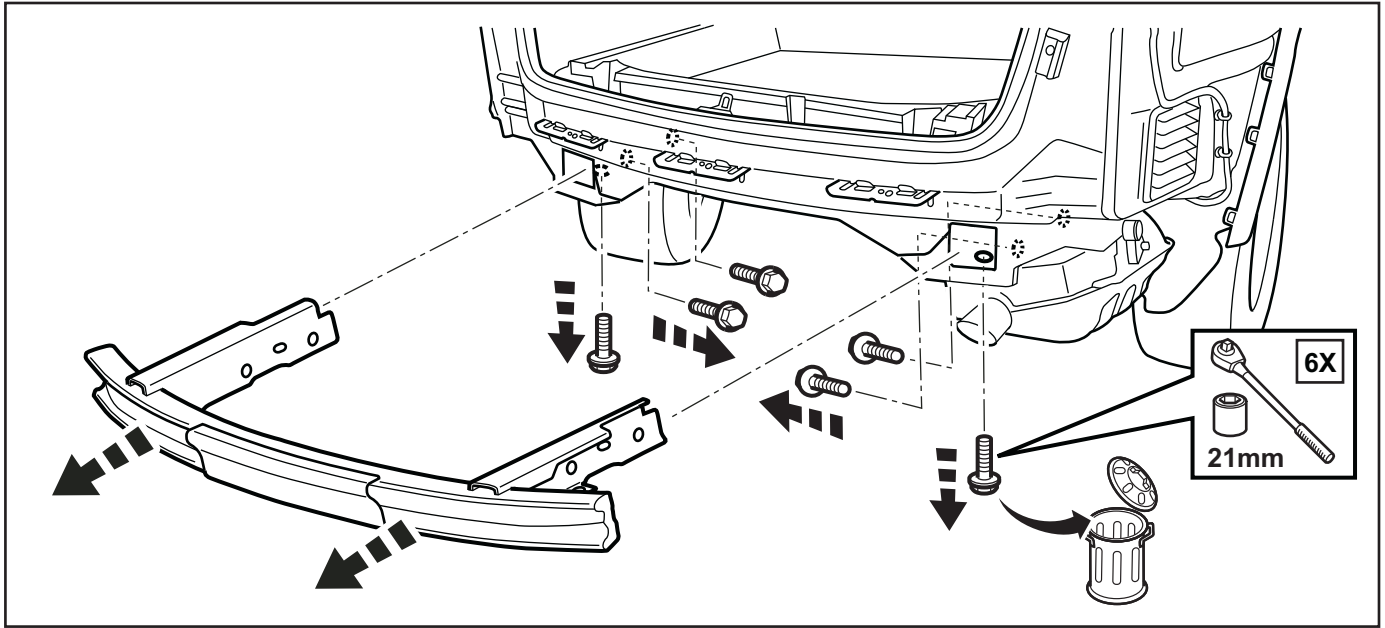

- 3. Mueva la fascia trasera hacia abajo para colocarla sobre el banco de apoyo. Frote el área con tiza blanca para resaltar el rectángulo y las ranuras que se indican en la superficie inferior del guardabarros.

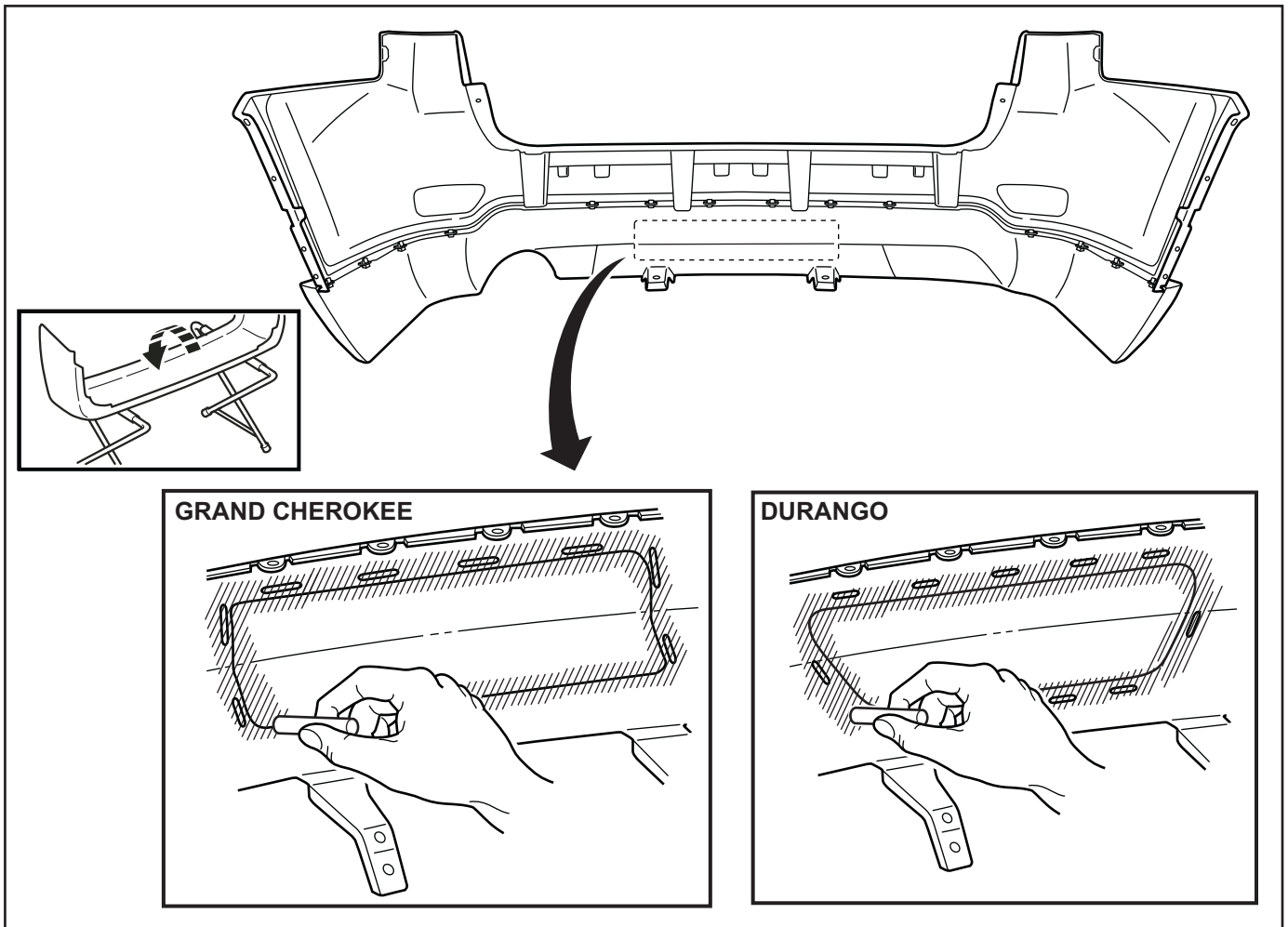

GRAND CHEROKEE

4. Taladre los orificios de las aberturas de lengüeta conforme al trazo de las áreas, tal como se ilustra. Utilice una broca de 1/8" (3.4mm) para las seis ranuras superiores y una broca de 3/32" (2.3mm) para las dos ranuras inferiores. Cerciñese de taladrar ambos extremos de las ranuras.

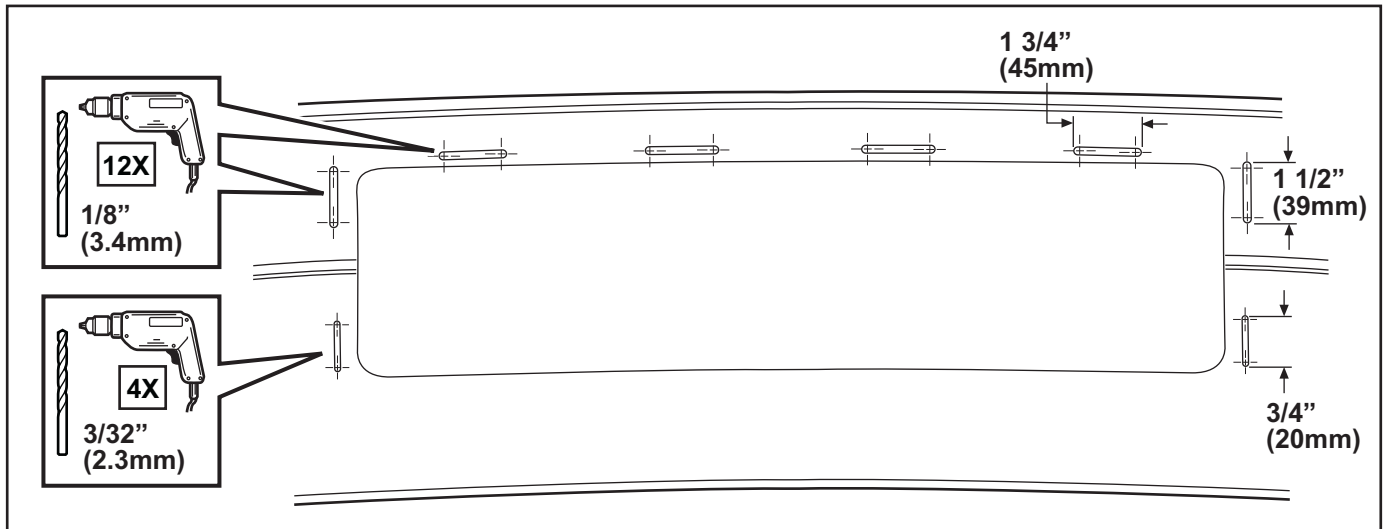

5. Corte las áreas sobrantes de las aberturas de lengüeta con una cuchilla de usos generales conforme al trazo de las áreas que se ilustran. Deseche las secciones que cortó.

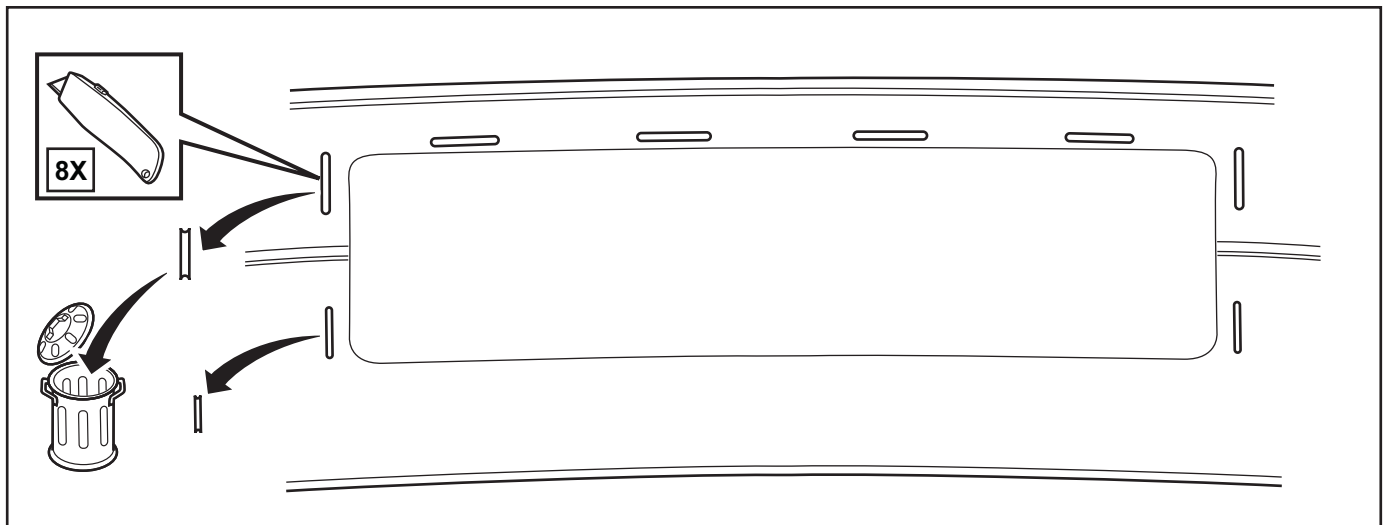

6. Corte la abertura central del bisel conforme al trazo de las aberturas que se ilustra. Deseche la sección que cortó.

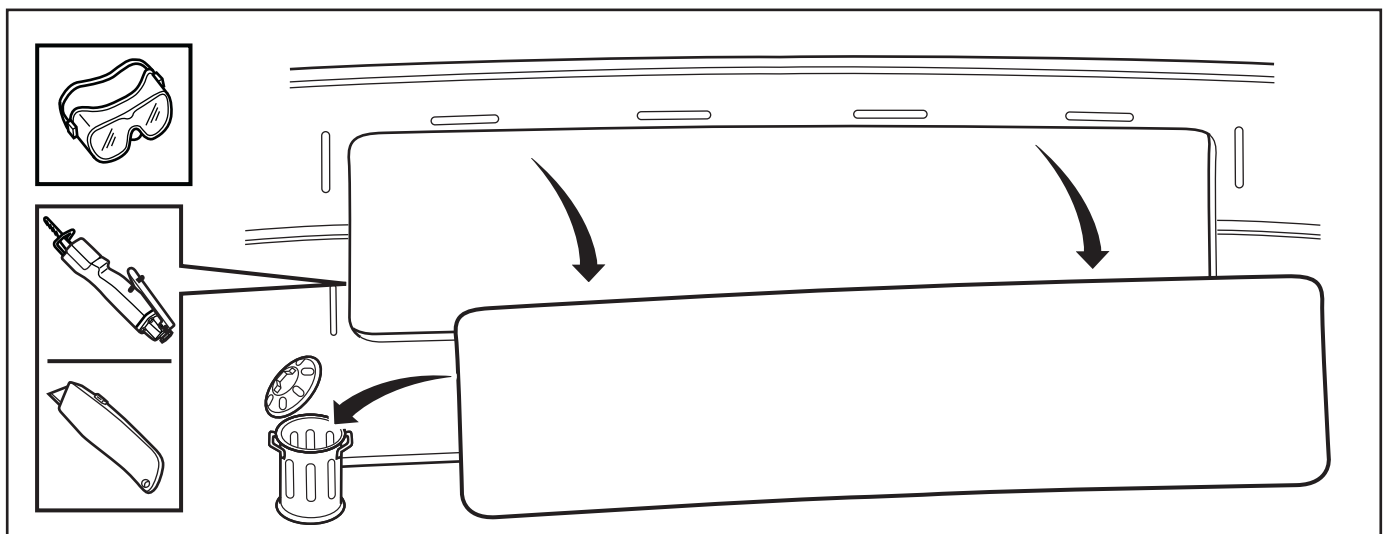

DURANGO

7. Taladre los orificios de las aberturas de lengüeta conforme al trazo de las áreas, tal como se ilustra. Utilice una broca de 3/32" (2.9mm) para las cinco ranuras superiores y una broca de 3/16" (4.6mm) para las dos ranuras inferiores. Utilice una broca de 1/8" (3.5 mm) para las dos ranuras laterales. Cerciñese de taladrar ambos extremos de las ranuras.

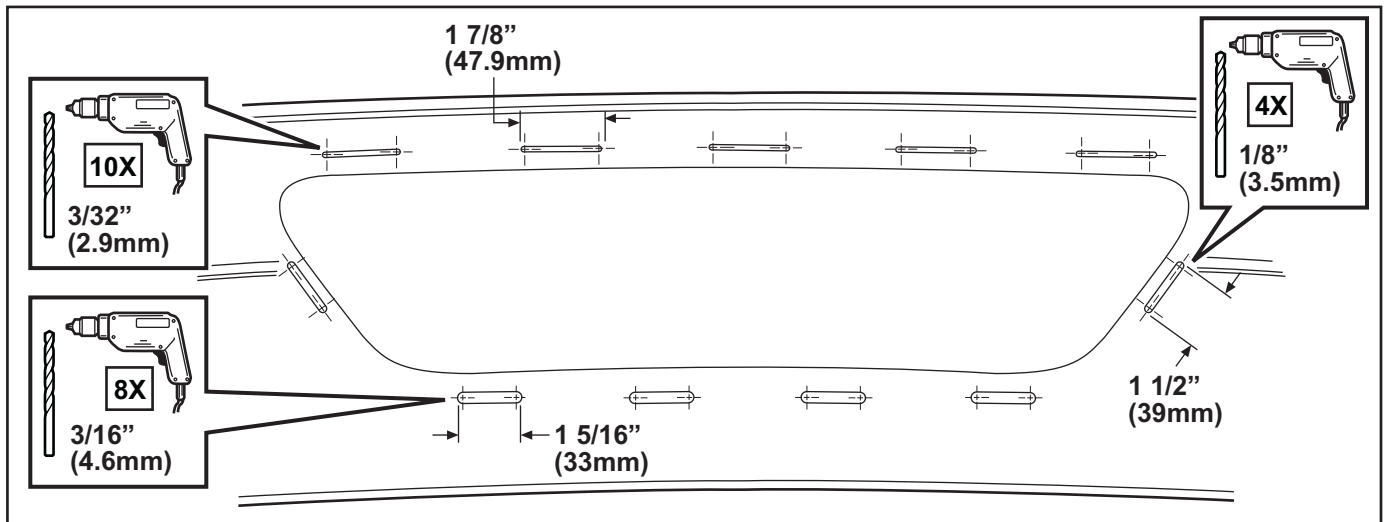

8. Corte las áreas sobrantes de las aberturas de lengüeta con una cuchilla de usos generales conforme al trazo de las áreas que se ilustran. Deseche las secciones que cortó.

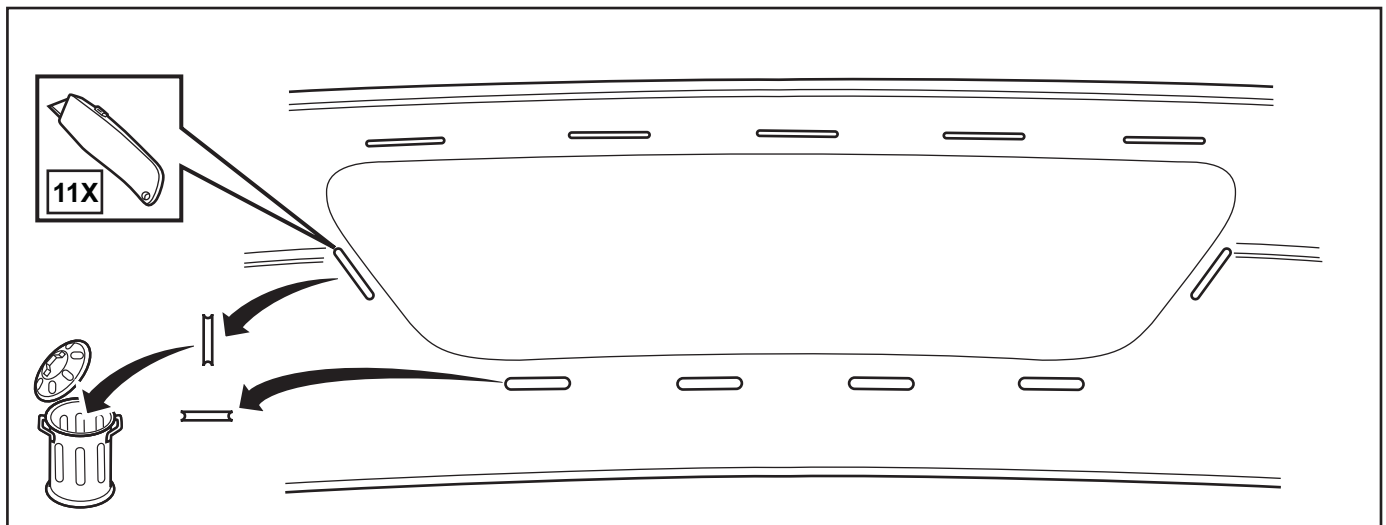

9. Corte la abertura central del bisel conforme al trazo de las aberturas que se ilustra. Deseche la sección que cortó.

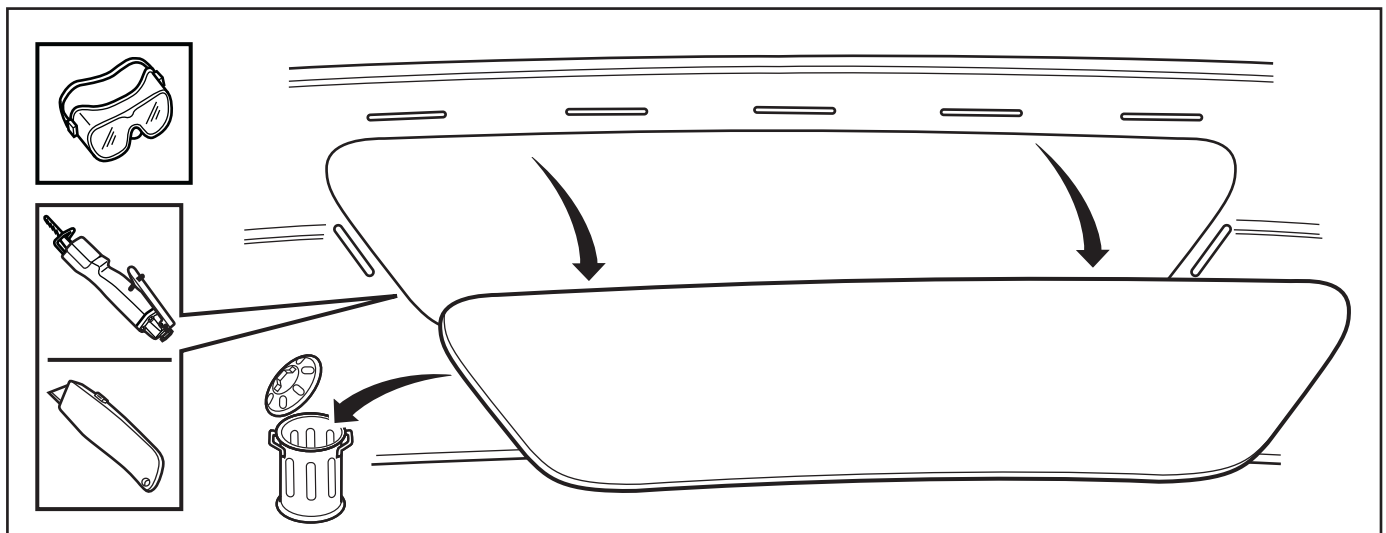

- 10. Presione el bisel en la abertura del guardabarros. Compruebe que todas las lengüetas están firmemente ajustadas a presión y fije con los dos (2) broches de resorte según se ilustra.

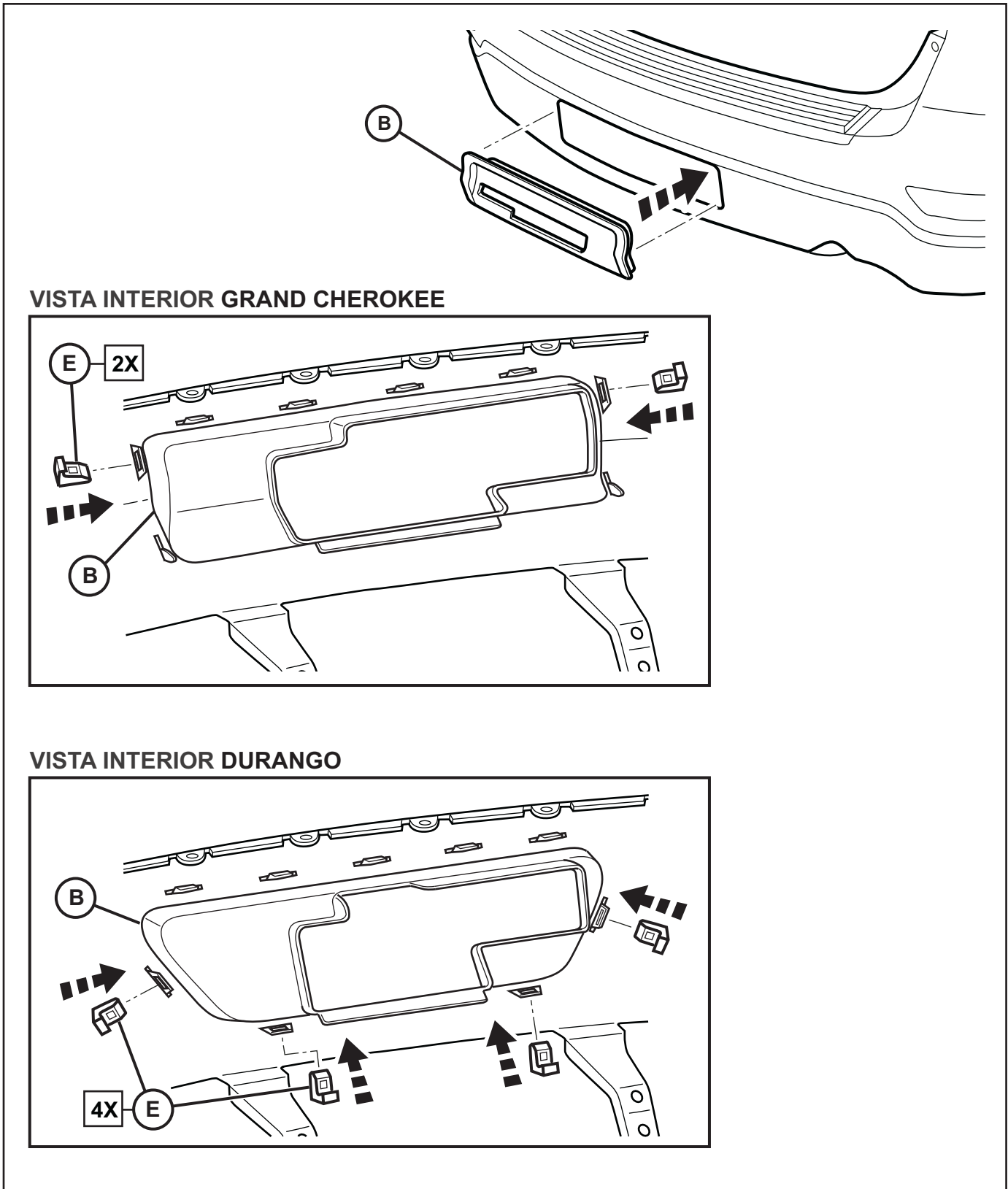

11. Utilice los ocho (8) pernos de 21mm que vienen con el equipo para instalar el nuevo conjunto de enganche. Apriete los ocho (8) pernos a 165 Nm (122 pies/lb.)

NOTA: Para el desmontaje del travesaño en el paso 2 intervienen seis (6) pernos. Para la instalación del enganche para remolque se requieren ocho (8) pernos.

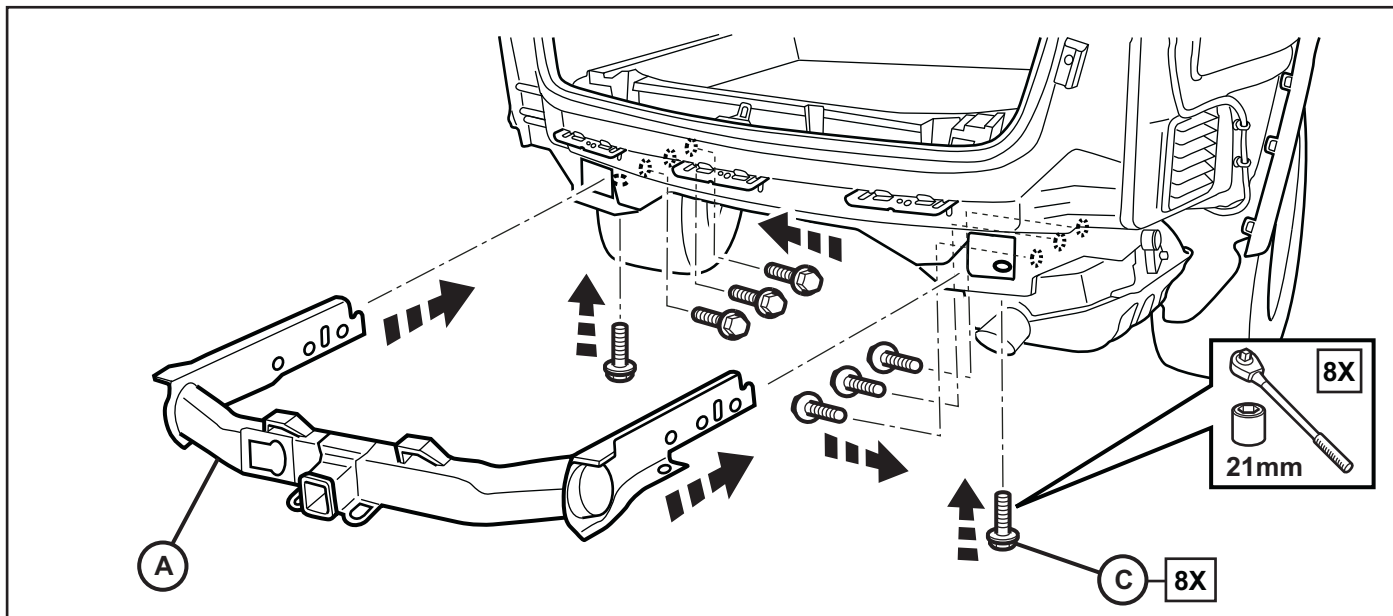

12. Reinstale la fascia trasera.

