

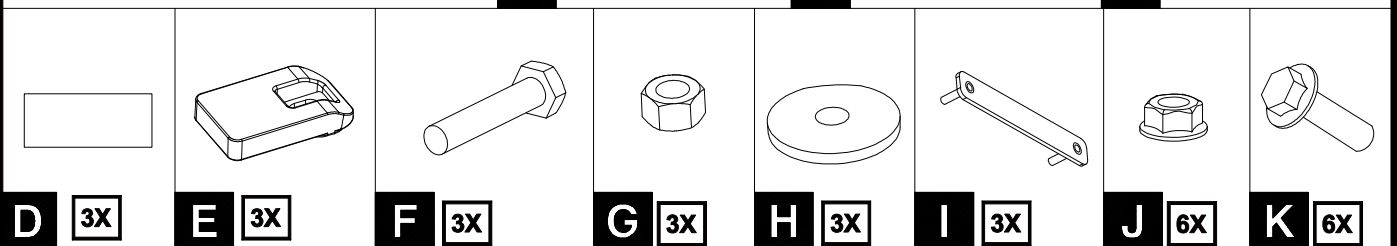

DODGE DURANGO

TUBULAR SIDE STEPS
ESTRIBOS LATERALES TUBULARES
MARCHEPIEDS TUBULAIRES

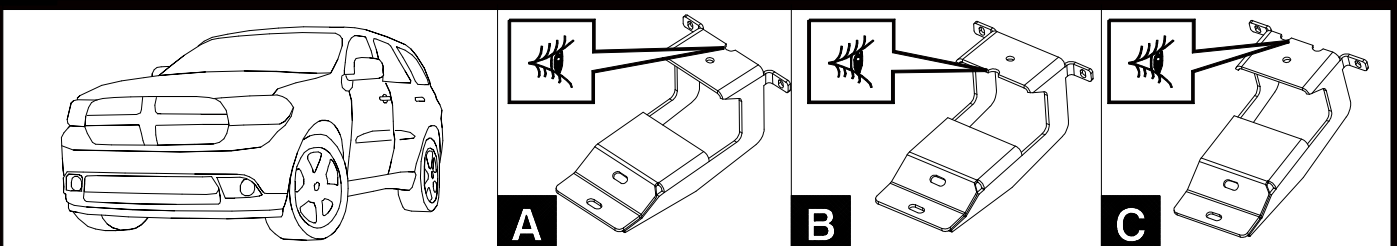
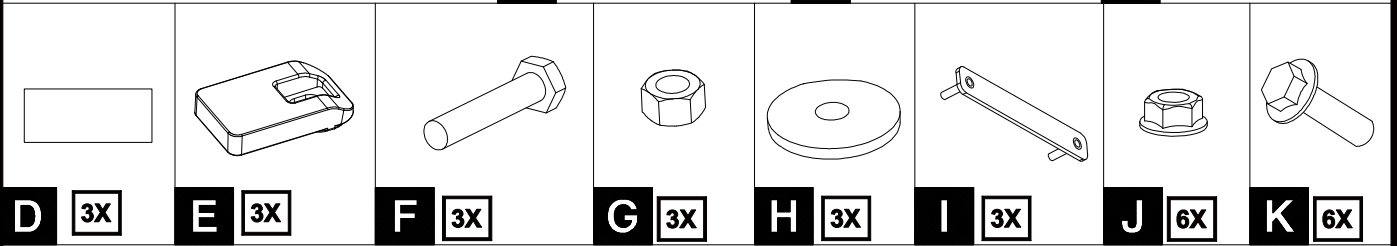
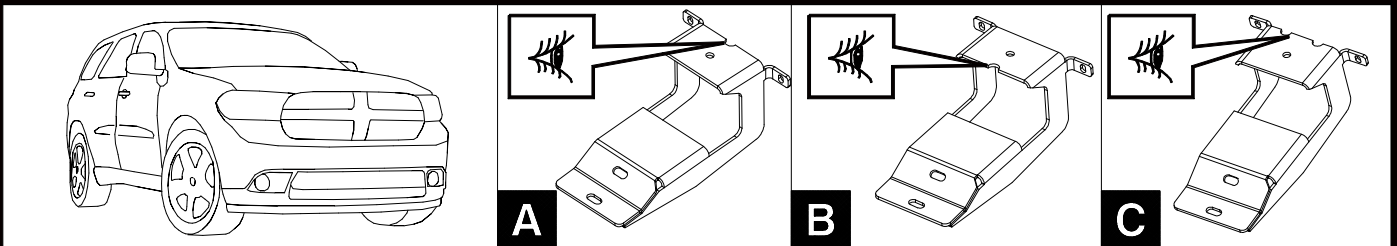

PROBLEMS? QUESTIONS? PLEASE CALL:

PROBLEMAS? ¿PREGUNTAS? PÓNGASE EN CONTACTO CON:

DES PROBLÈMES ? DES QUESTION ? VEUILLEZ CONTACTER:

1-866-639-8896

FAX

FAX 1-515-299-4594

FAX

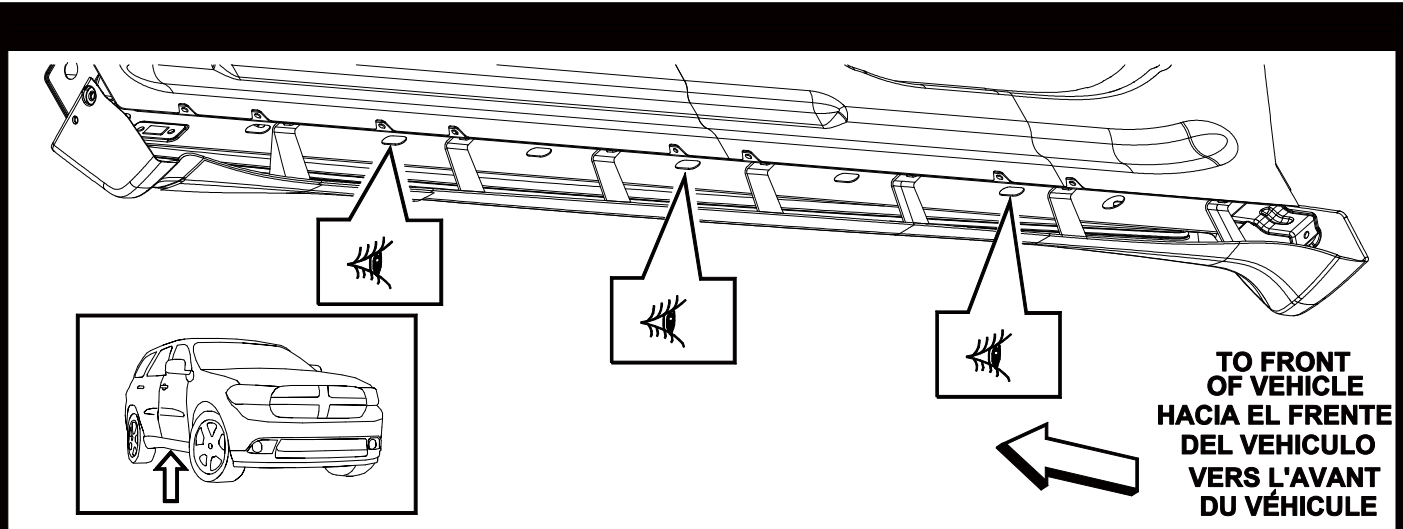

Add patch of Lock & Seal Adhesive - blue (#04318031) to bolt (F)
Añadir parche de bloqueo y cierre adhesivo - azul (# 04318031) al perno (F)
Ajouter patch de Lock & Seal Adhésif - bleu (# 04318031) sur la vis (F)

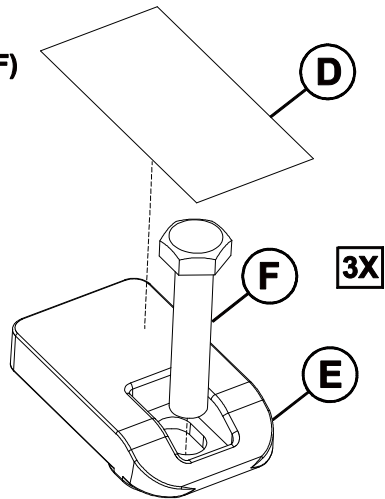

1

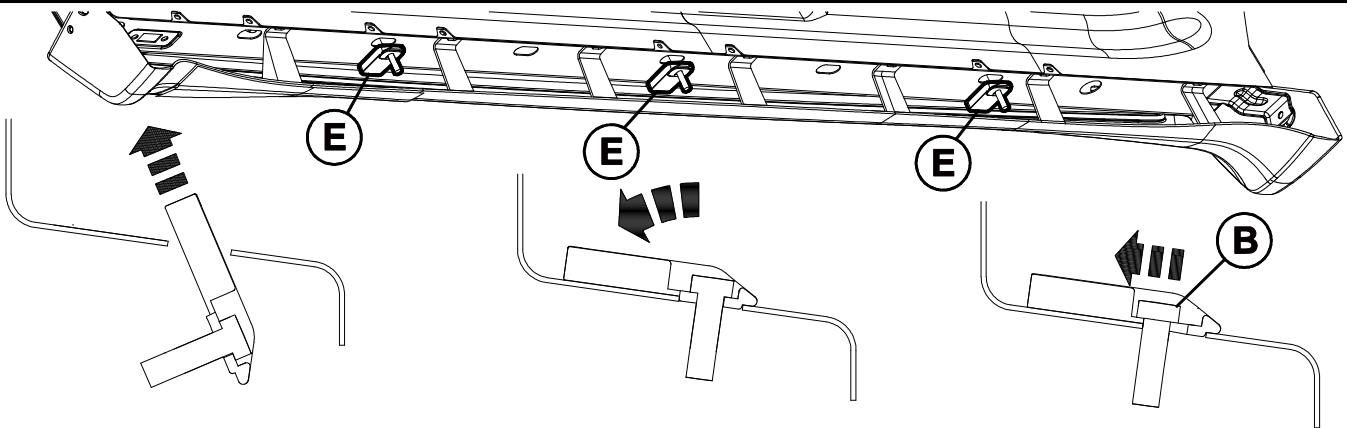

Use a paint marker to mark bottom of bolt. Use this marking to ensure plate has not rotated during assembly.

Use un marcador de pintura para marcar la parte inferior del perno. Utilice esta marca para asegurar la placa no ha girado durante el montaje.

Utilisez un marqueur pour marquer bas de boulon. Utilisez ce marquage pour assurer la plaque n'a pas tourné lors de l'assemblage.

2

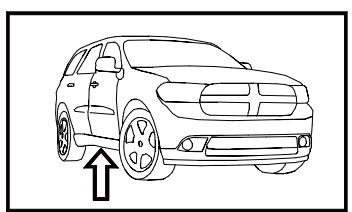
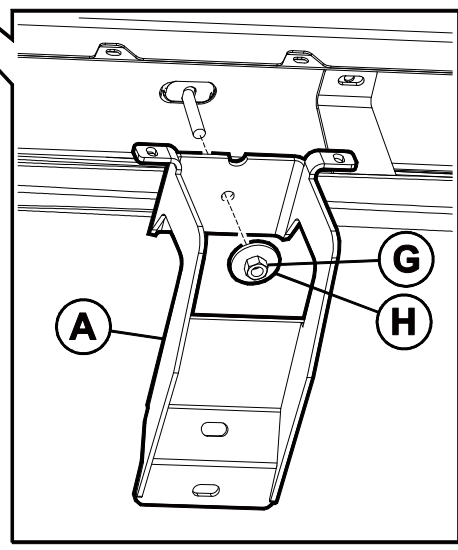
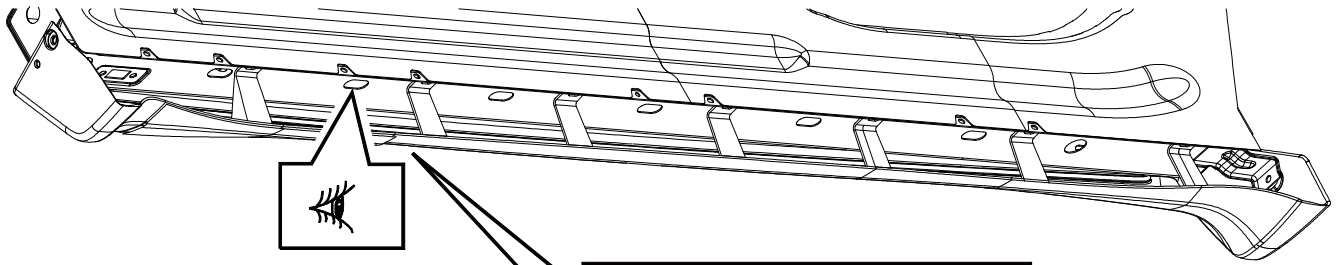

3

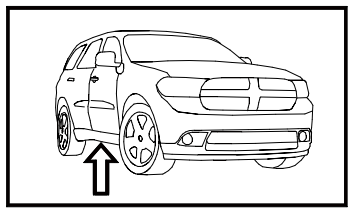
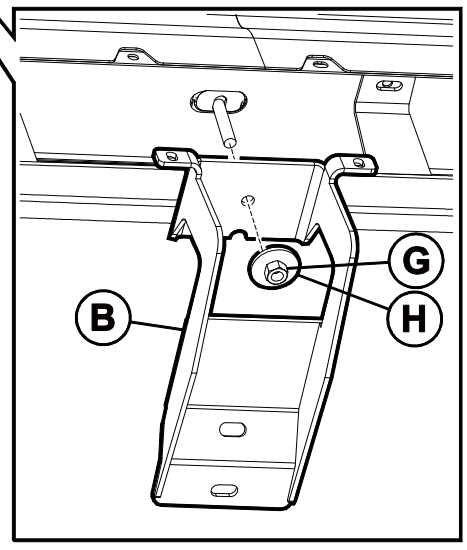
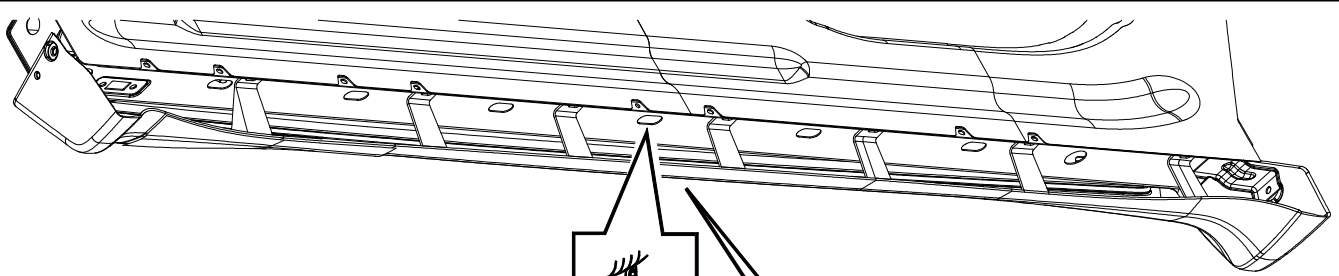

4

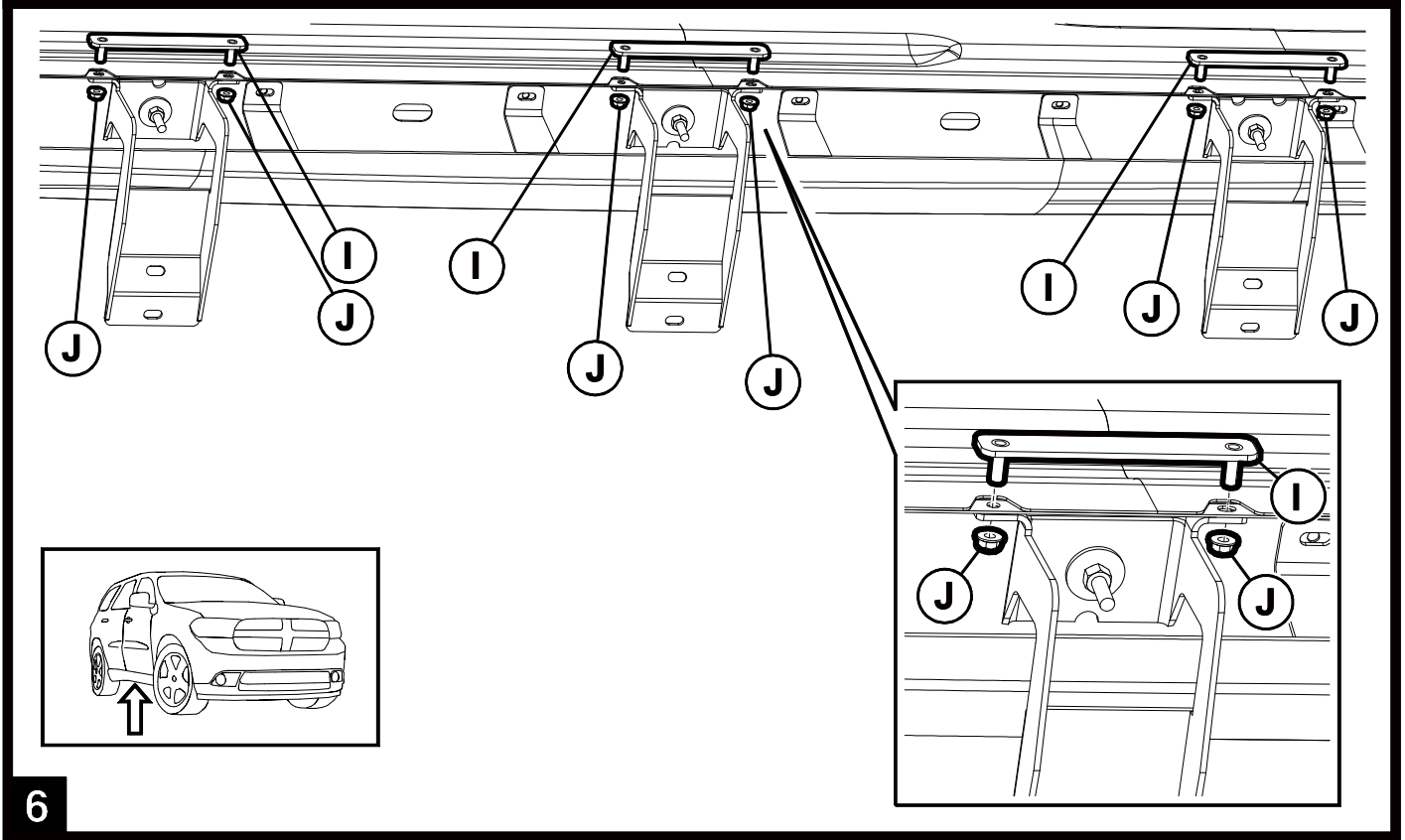
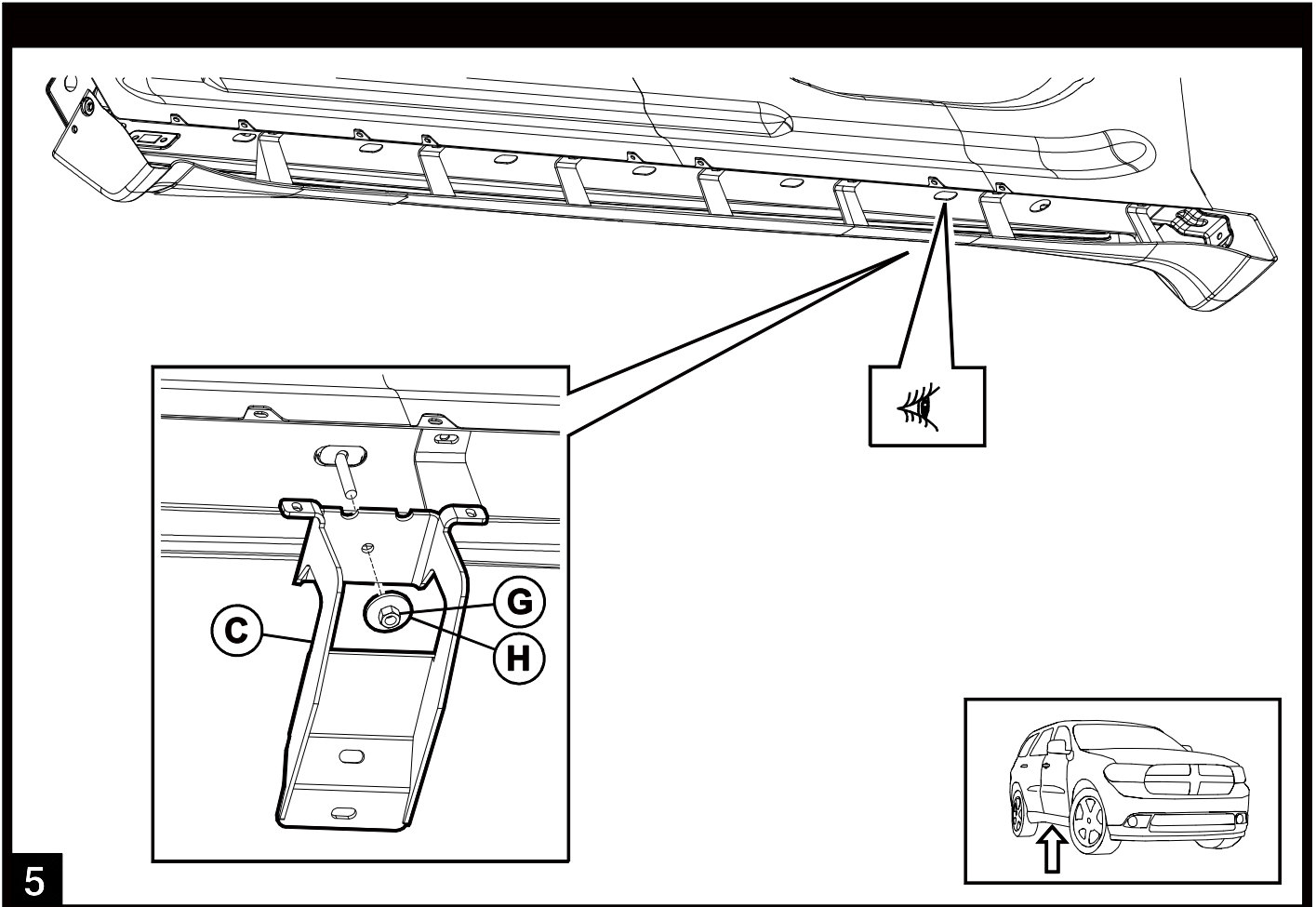

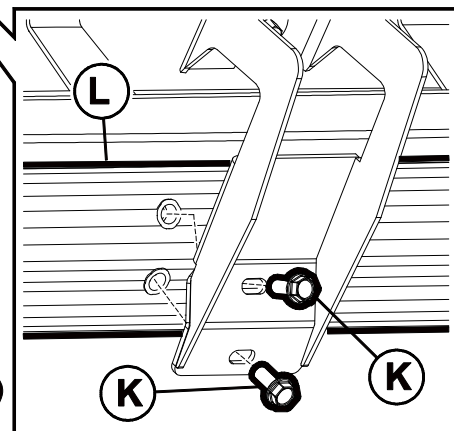
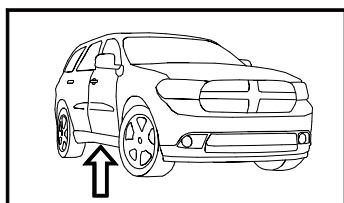
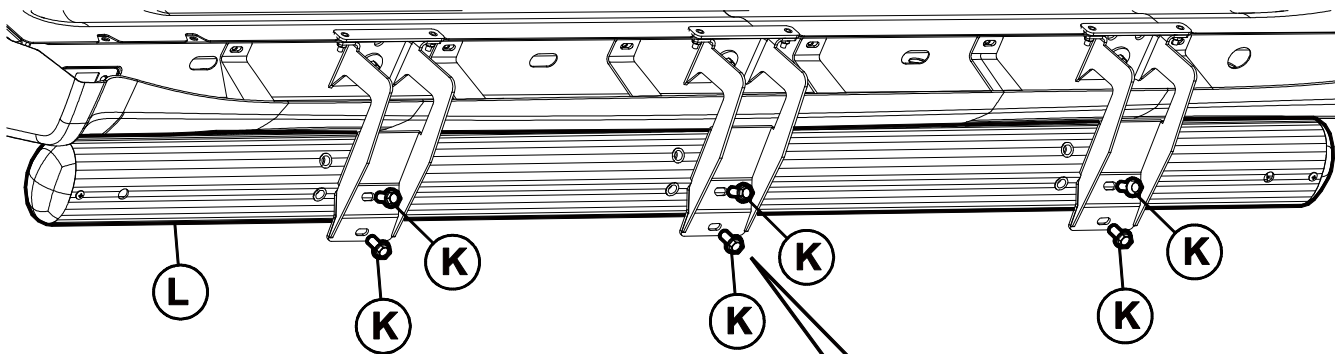

Add patch of Lock & Seal Adhesive - blue (#04318031) to bolt (K)
Añadir parche de bloqueo y cierre adhesivo - azul (# 04318031) al perno (K)
Ajouter patch de Lock & Seal Adhésif - bleu (# 04318031) sur la vis (K)

7

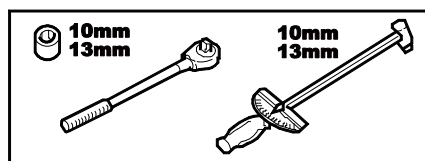
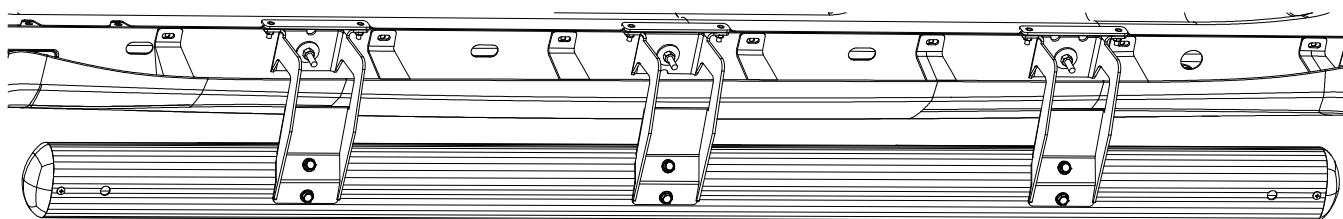

Tighten fasteners labeled "G" to 216 in-lbs ±12 int-lbs. (24 N-m ±1 N-m). Tighten fasteners labeled "I" to 70in-lbs. (8 N-m). Repeat for driver's side. Ensure marked bolt has not rotated. CAUTION - Do Not Overtorque

Apriete los sujetadores con la etiqueta "G" a 216 pulgadas-libras ± 12 pulgadas-libras. (24 Nm + \-1Nm). Apriete los sujetadores con la etiqueta "I" y 70 pulgadas-libras ± 12 pulgadas-libras (8Nm). Repita para el lado del conductor. Asegúrese marcados perno no ha rotado. PRECAUCIÓN - No apriete demasiado

Resserrez les attaches "G" jusqu'à 216in-lbs ±12 in-lbs. (24 N-m ±1 N-m). Resserrez les attaches "I" jusqu'à 70in-lbs ±12 in-lbs. (8 N-m ±1 N-m). Repetez l'operation du côté aconducteur. Assurez-vous marqué boulon n'a pas tourné. Attention: Ne pas surcoupler

8

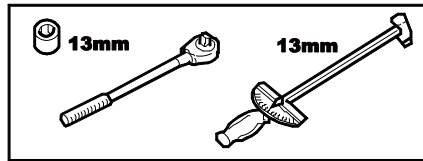
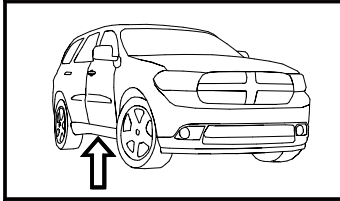
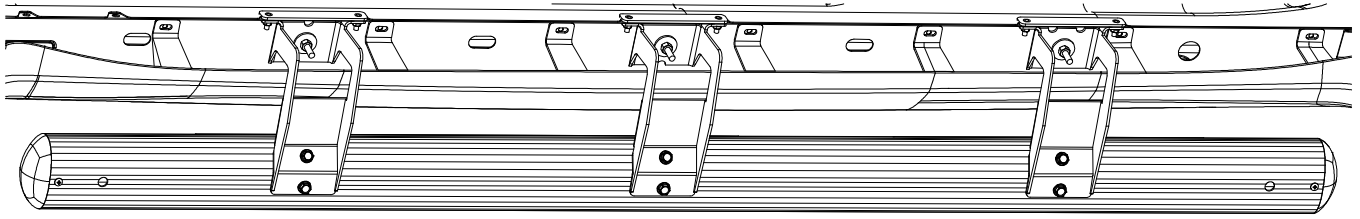

Tighten bolts attaching brackets to step to 100 in-lbs \pm 12 in-lbs. (17 N-m \pm 1 N-m). Repeat for driver's side.

CAUTION - Do Not Overtorque

Apriete los pernos de los soportes de fijación al paso a 100 pulgadas-libras \pm 12 pulgada-libras (17N-m \pm 1 Nm) Répétez l'operation du côté conducteur.

Precaucion: No apriete demasiado

Serrer les boulons les pattes de fixation à l'étape de 100 pouces-livres \pm 12 pouce-livres (17N-m \pm 1 Nm) Repita el procedimiento en el lado del conductor.

Attention: Ne pas surcoupler

9

Product Care: Chrome Cleaner; Excellent chrome surfaces cleaner. Ideally suited for all bright metals. Specifically formulated for use on surfaces that are exposed to weather or water. Use on chrome bumpers, wheels, including chrome clad wheels, mirror backs and grilles. Part No. 04318013 16 Oz. bottle

Cuidado del

producto: Chrome más limpia; cromo excelente limpiador de superficies. Ideal para todos los metales brillantes. Específicamente formulado para su uso en superficies que están expuestas a la intemperie o al agua. El uso de defensas cromadas, llantas, incluyendo el cromo ruedas vestido, la espalda espejo y rejillas. Parte N ° 04318013 16 Oz. botella

Entretien des

produits: Nettoyeur de chrome; chrome Excellent surfaces propres. Idéal pour tous les métaux brillants. Spécifiquement formulé pour une utilisation sur des surfaces qui sont exposées aux intempéries ou de l'eau. Utilisez le pare-chocs chromés, des roues, y compris les jantes chromées plaquées, dos miroir et grilles. Partie n ° 04318013 16 Oz. bouteille