

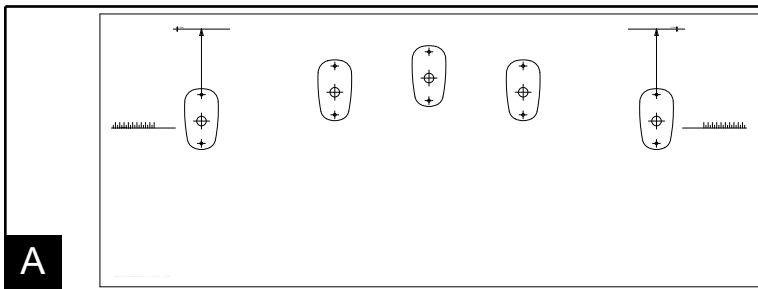

# DODGE RAM Clearance Lights

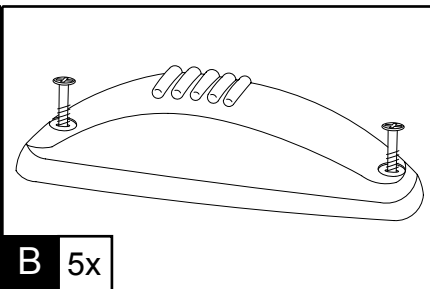

**A**



**B 5x**

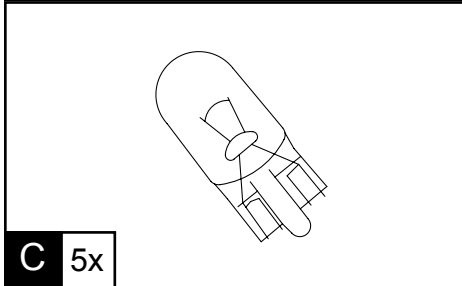

**C 5x**

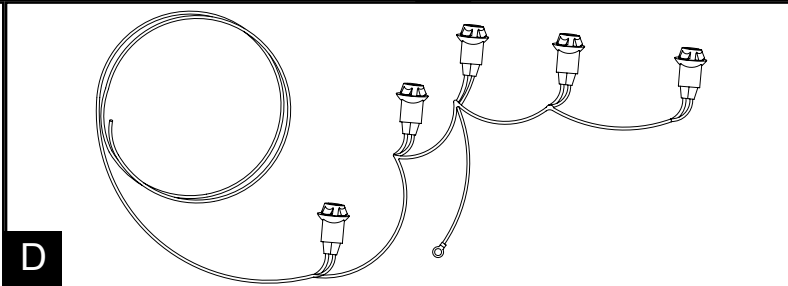

**D**

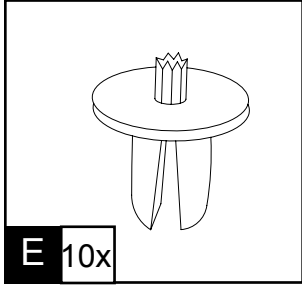

**E 10x**

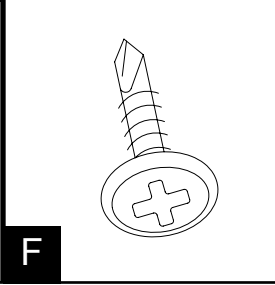

**F**

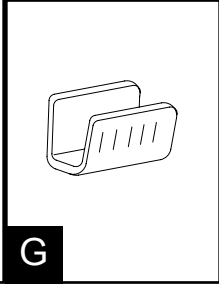

**G**

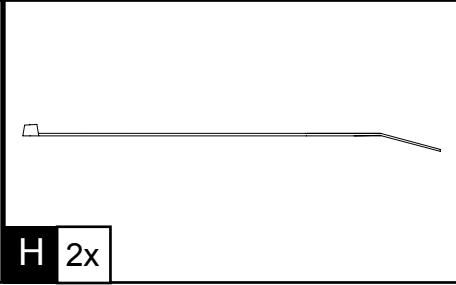

**H 2x**

823100508AB  
Corrosion  
Inhibitor

10mm

Ø 22mm(7/8")

Ø6.35mm(1/4")

Torx 20

**Remove headliner Refer to vehicle shop manual.  
Retire el toldo. Refiérase al manual de tienda del automóvil.  
Enlevez le vaigrage. Référez au manuel.**

**1**

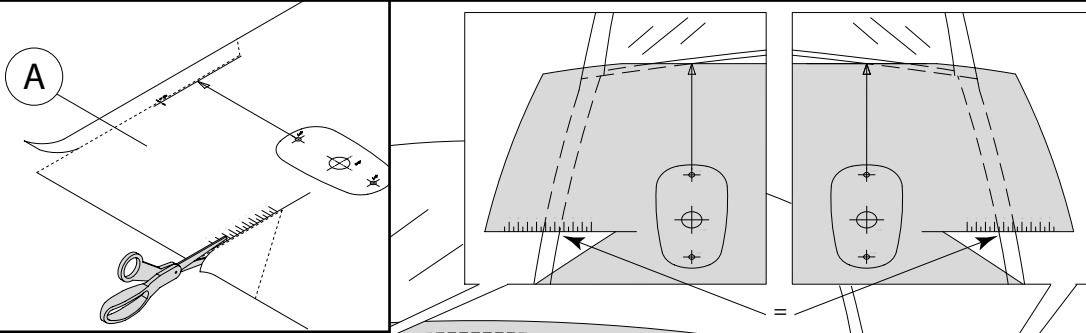

**2**

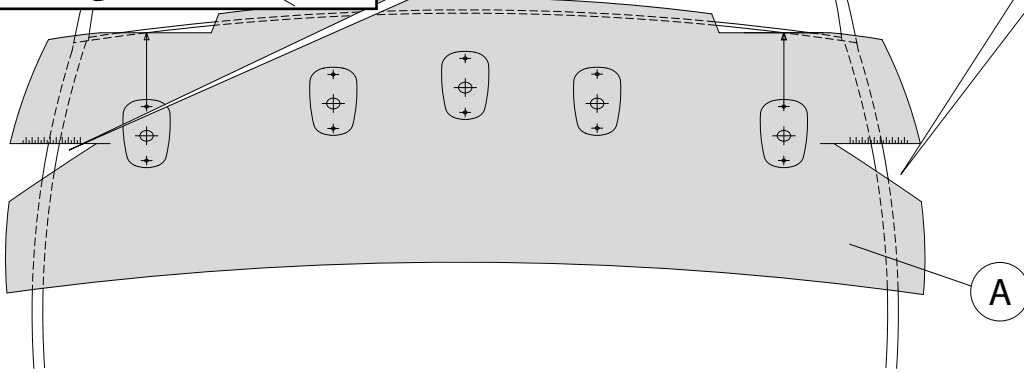

**3**

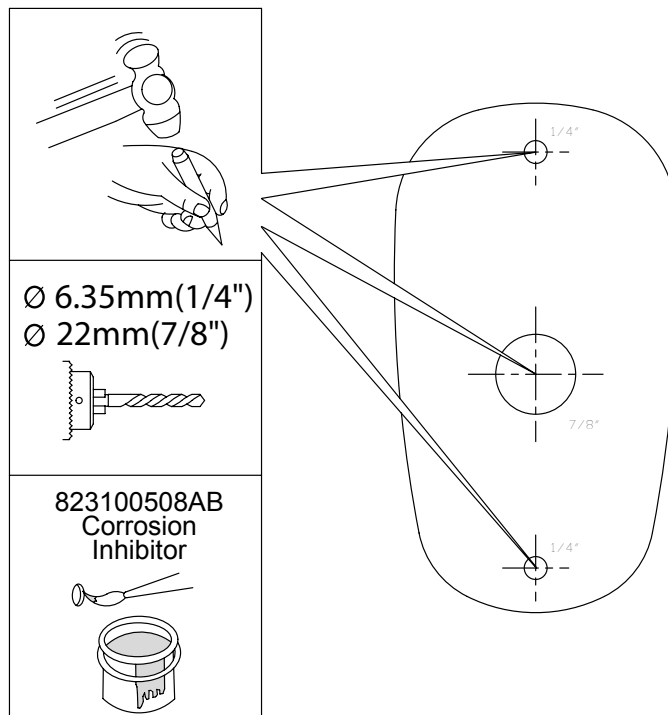

**4**

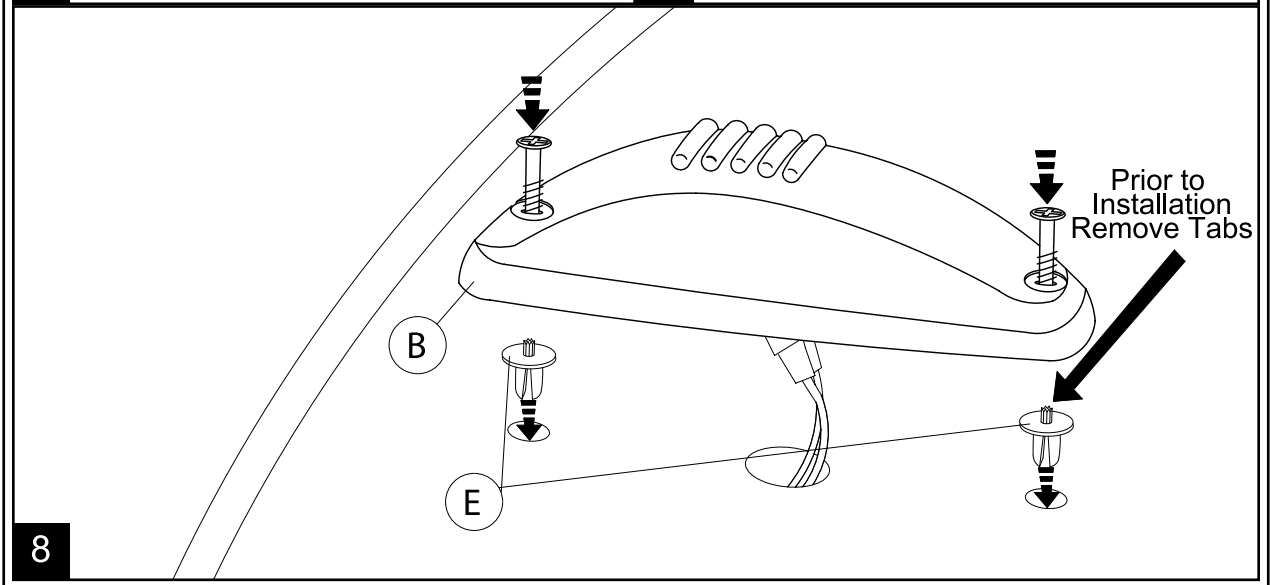
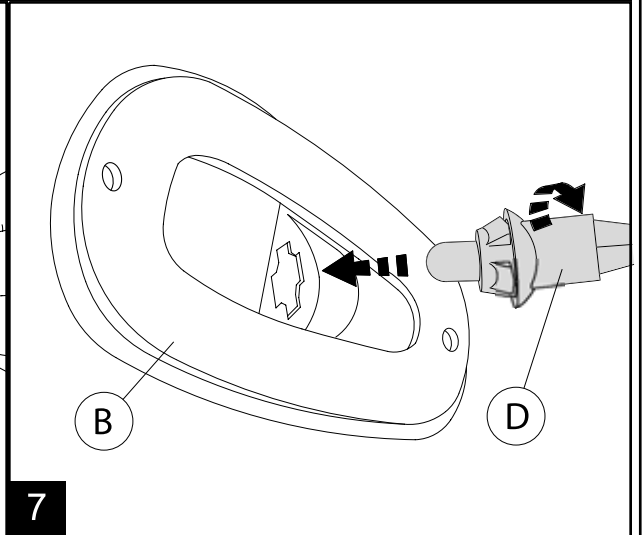
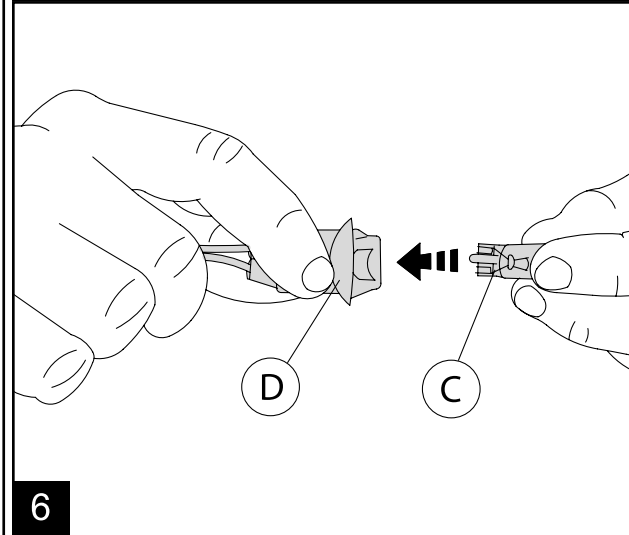
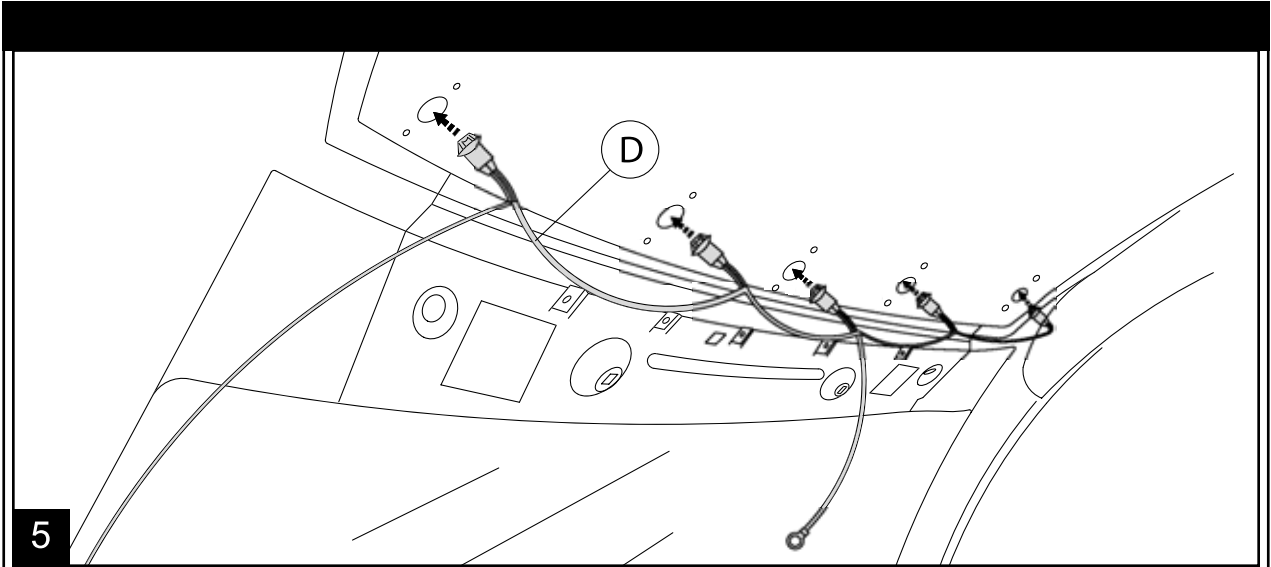

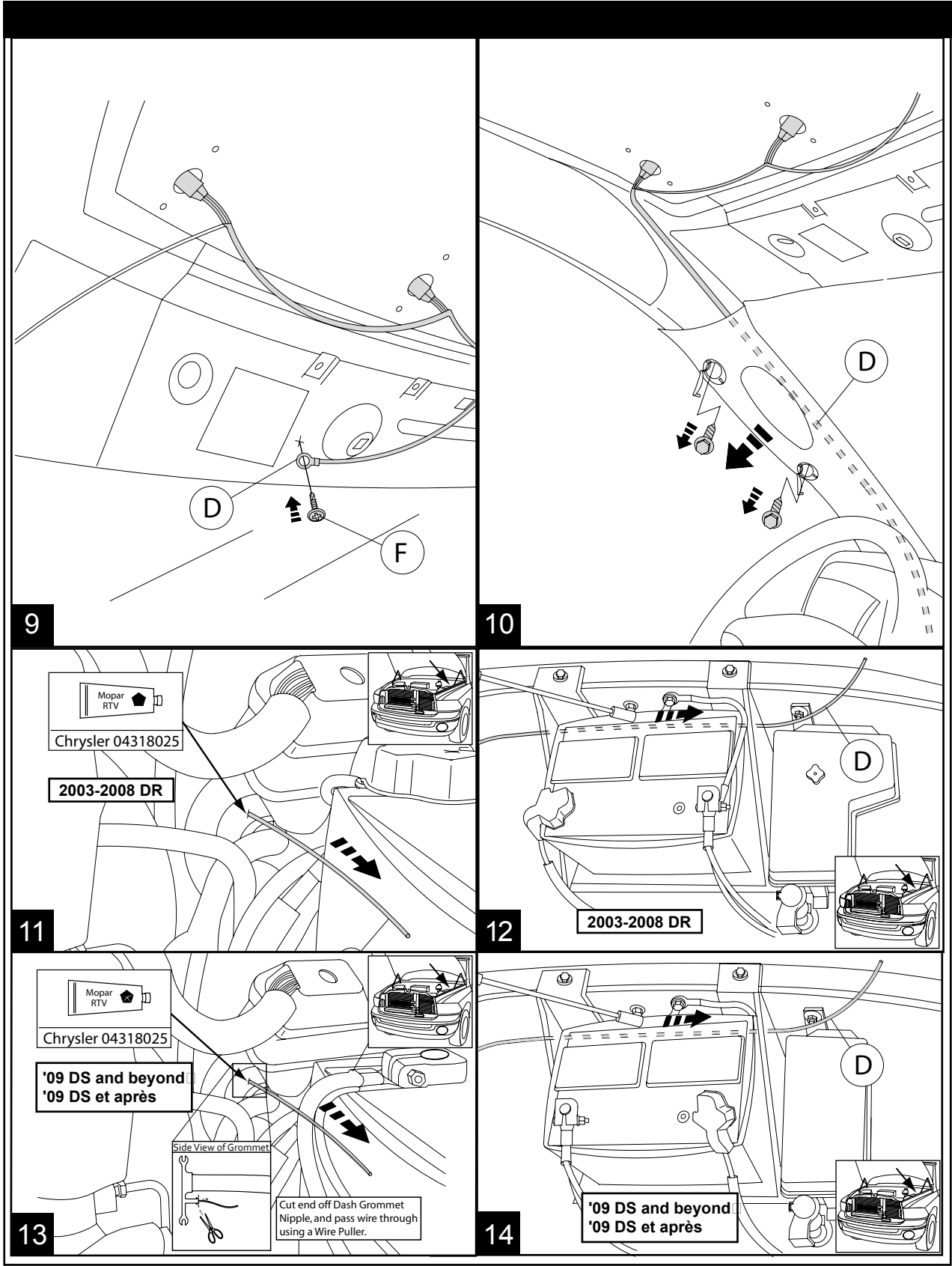

Mopar RTV  
Chrysler 04318025

2003-2008 DR

2003-2008 DR

Mopar RTV  
Chrysler 04318025

'09 DS and beyond  
'09 DS et après

Side View of Grommet

Cut end off Dash Grommet Nipple, and pass wire through using a Wire Puller.

'09 DS and beyond  
'09 DS et après

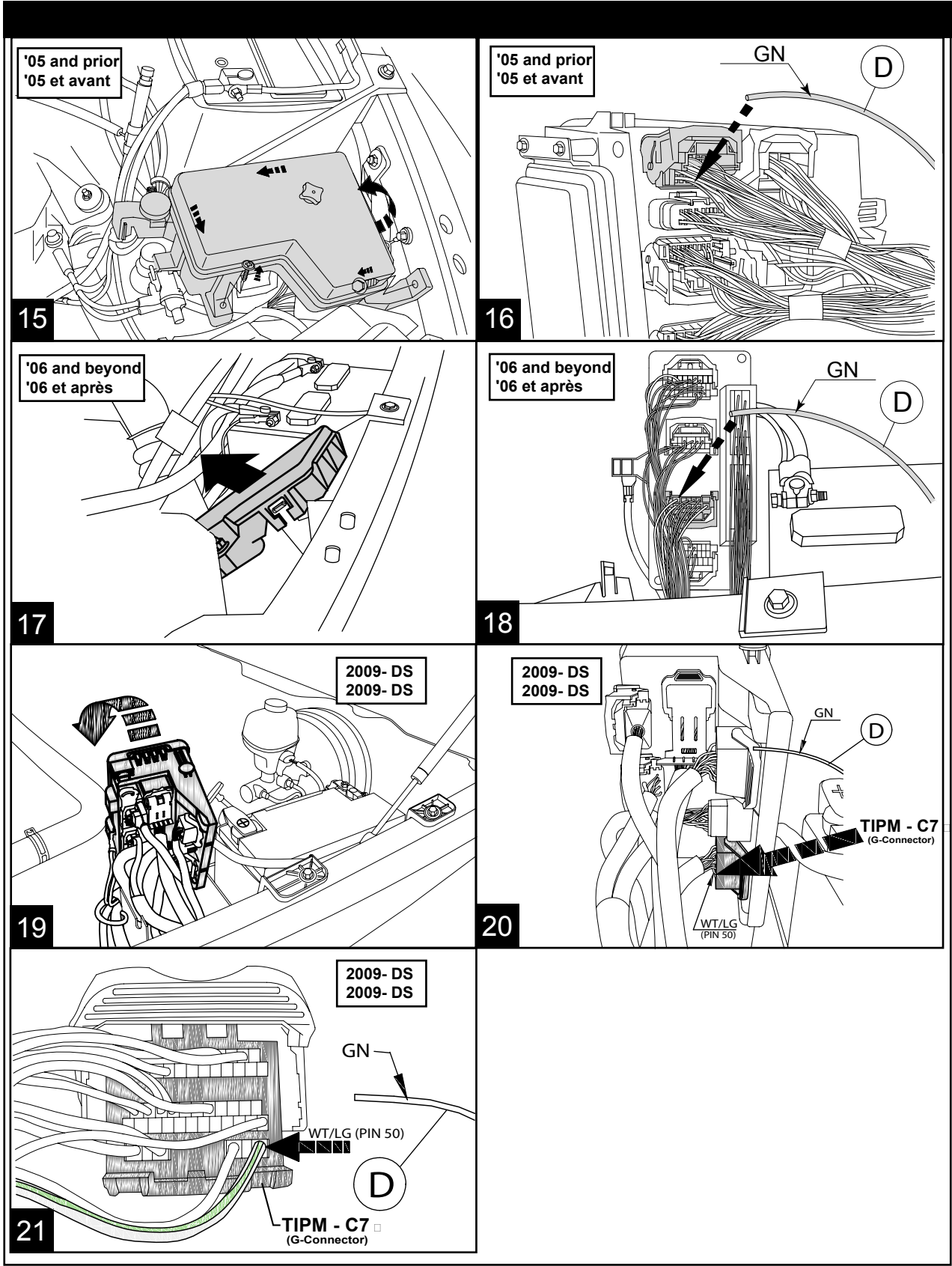

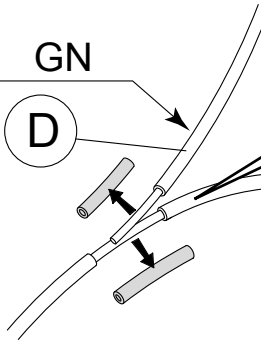
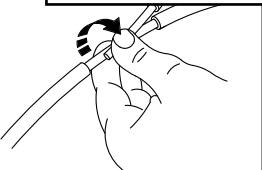
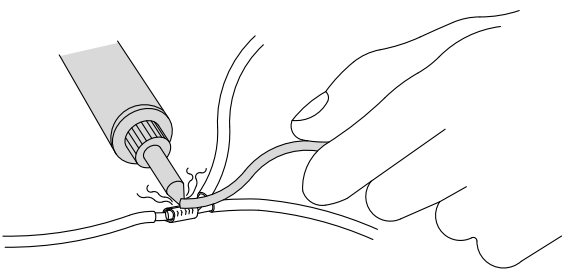
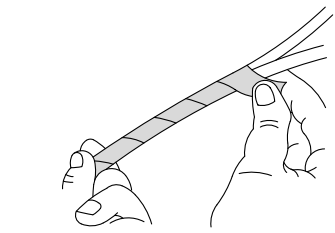
	<p>'03 and prior - center splice to the "LH Park Lamp" feed at PDC, Cav #19 = PK/VT</p>	<p>'03 et avant - brancher aux le fil de "garer la lampe gauche" a PDC, Cav #19 = PK/VT</p>				
	<p>'04 and '05 - center splice to the "LH Park Lamp" feed at PDC, Cav #19 = WT/YL</p>	<p>'04 et '05 - brancher aux le fil de "garer la lampe gauche" a PDC, Cav #19 = WT/YL</p>				
	<p>'06 - '08 - center splice to the "LH Park Lamp" feed at PDC C9, Cav #10 = WT/GY</p>	<p>'06 - '08 - brancher aux le fil de "garer la lampe gauche" a PDC C9, Cav #10 = WT/GY</p>				
	<p>'09 and beyond - center splice to the "LH Park Lamp" feed at C7 (G-Conn.), Cav #50 = WT/LG</p>	<p>'09 et après - brancher aux le fil de "garer la lampe gauche" a C7 (G-Conn.), Cav #50 = WT/LG</p>				
						
<p>22</p>						
<p>Turn on lights <input type="checkbox"/></p>	<input type="checkbox"/>	<input type="checkbox"/>	<input type="checkbox"/>	<input type="checkbox"/>	<input type="checkbox"/>	<p>Verify lights turn on</p>
<p>Turn off lights <input type="checkbox"/></p>	<input type="checkbox"/>	<input type="checkbox"/>	<input type="checkbox"/>	<input type="checkbox"/>	<input type="checkbox"/>	<p>Verify lights turn off</p>