

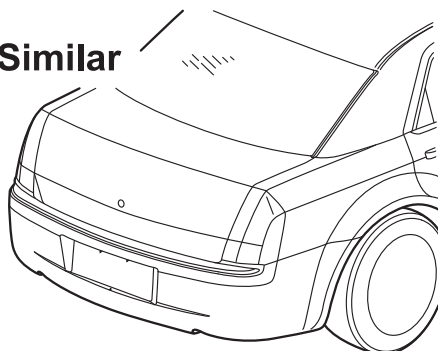

# CHRYSLER 300 DODGE CHARGER MAGNUM Satellite Radio

<b>A</b>		<b>B</b>	<b>C</b> 4X
<b>D</b> 300/Charger	<b>MAGNUM</b>	<b>E</b>	<b>F</b>
<b>G</b> 4X	<b>H</b>	<b>I</b>	<b>J</b>
<b>K</b> 3X	<b>L</b> 2X		
	<b>SCRAP CARDBOARD</b> APPROX. 11"x17" (279mm x 432mm)		

300 Shown,  
CHARGER Similar



MAGNUM

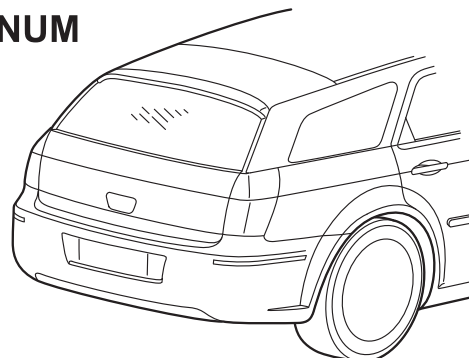

# CHRYSLER 300/DODGE CHARGER

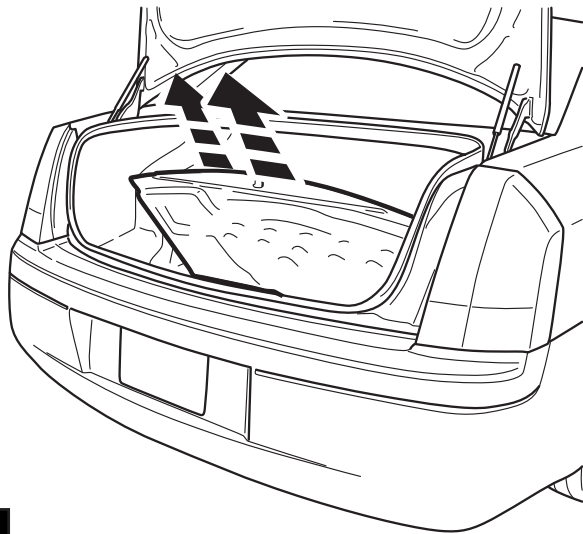

1

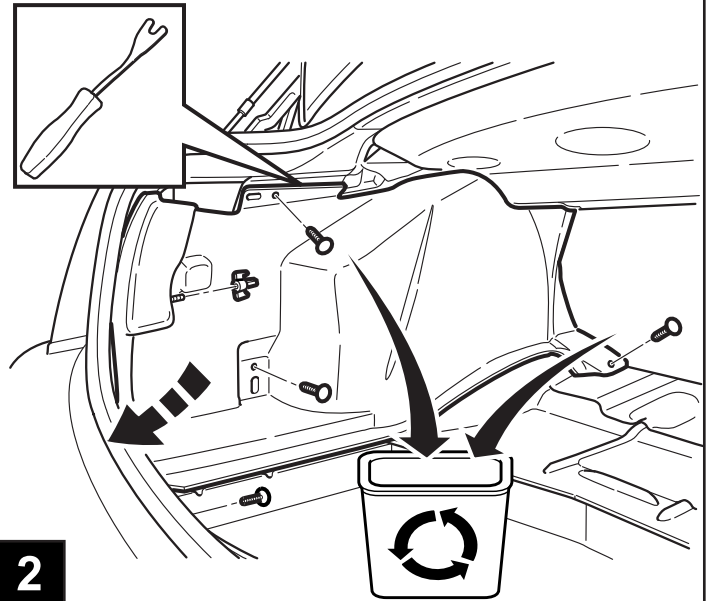

2

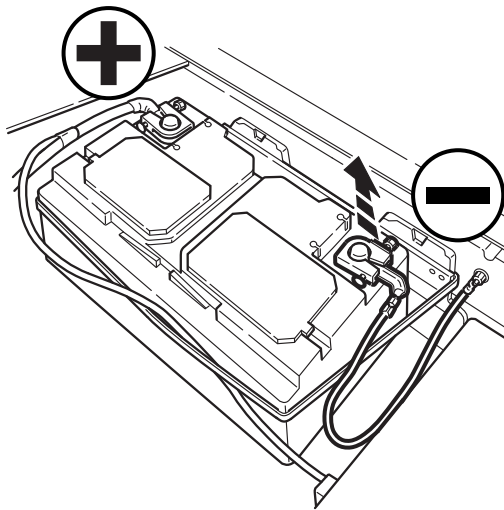

3

Disconnect and isolate negative battery cable.

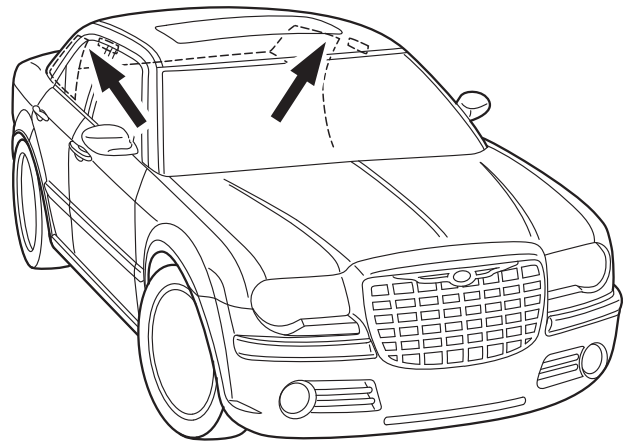

4 - 5

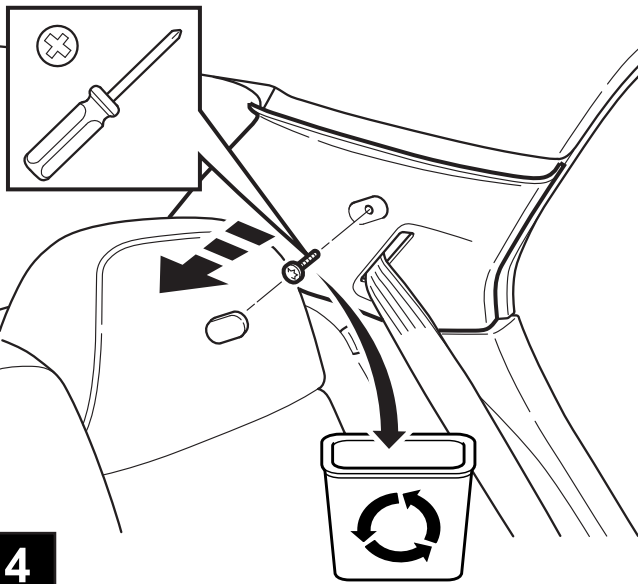

4

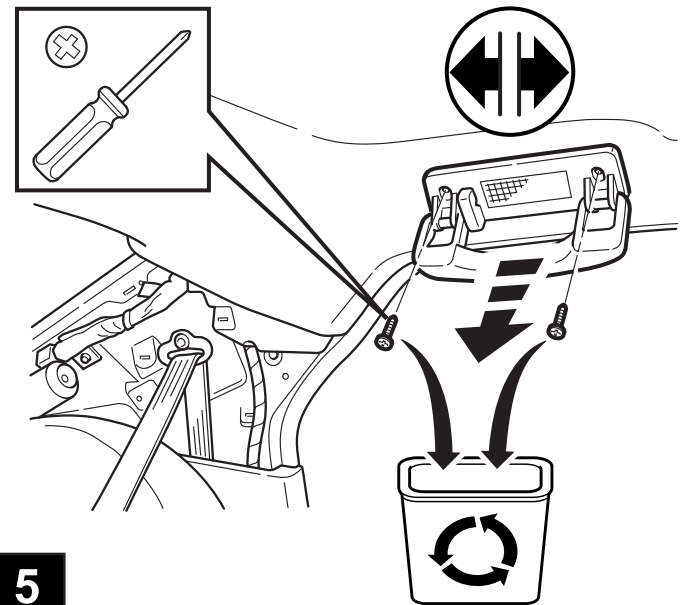

5

# CHRYSLER 300/DODGE CHARGER

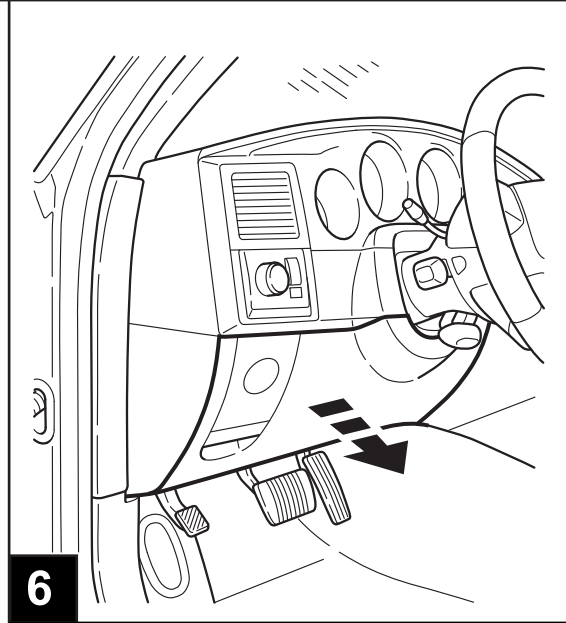

6

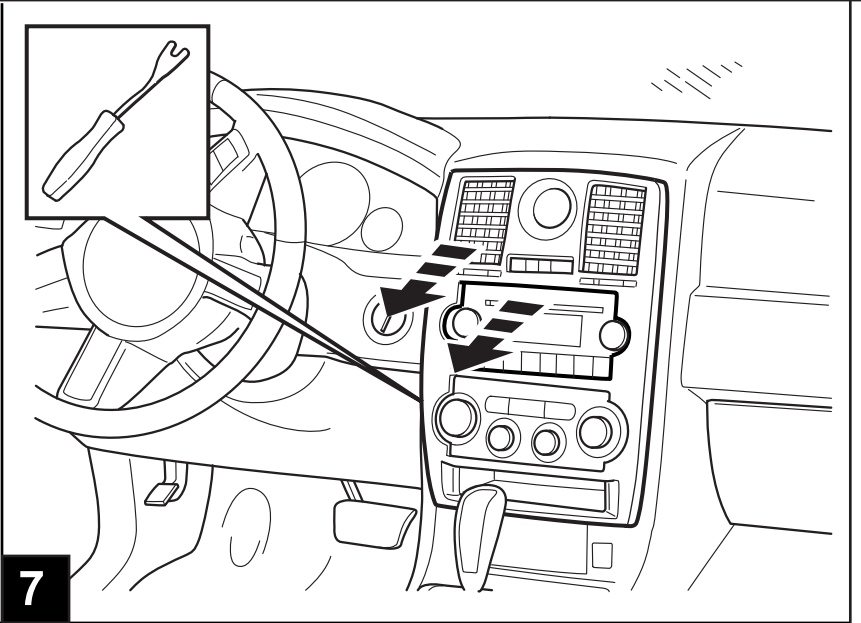

7

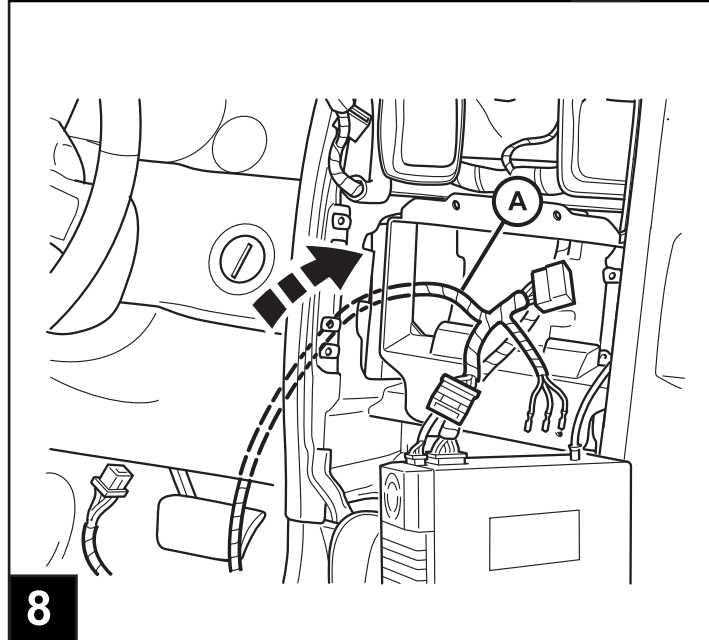

8

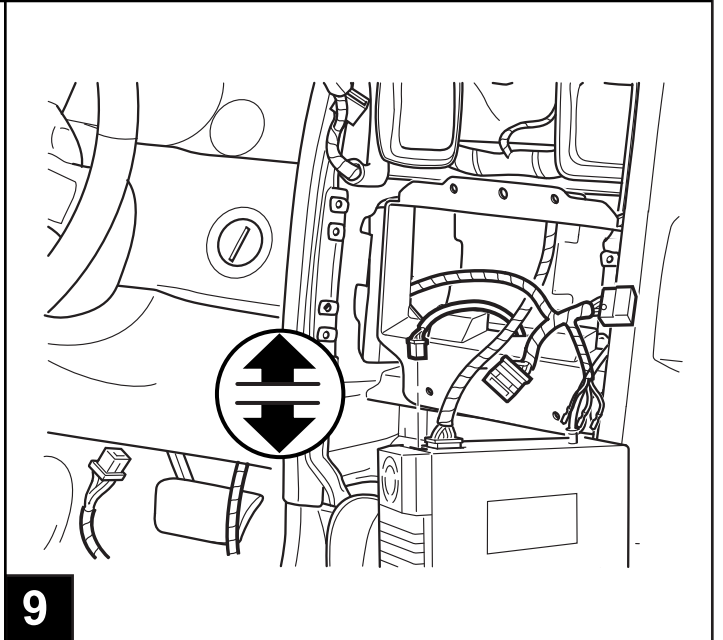

9



Lift up Only, Do Not Remove.

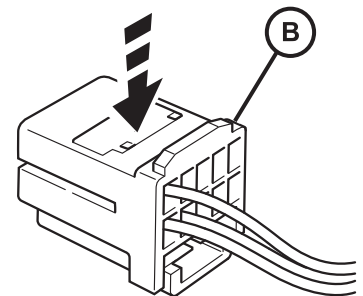
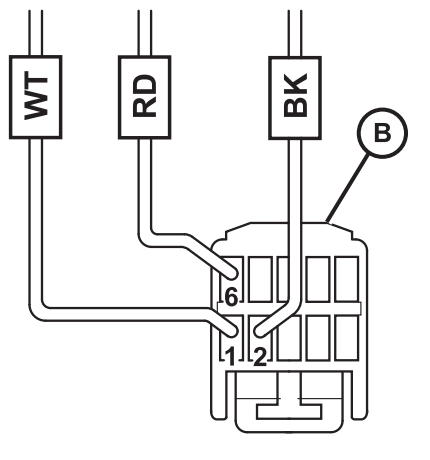

10

1. Plug and lock (3) harness wires into 10-way connector as shown. If radio does not have existing 10-way connector, use the one supplied in kit (Item B). In some vehicles there will be wires present in pins 1, 2, and 6 of the 10-way connector. See Step 10a.

# CHRYSLER 300/DODGE CHARGER

2.\* If Pins 1, 2, and 6 are the only pins present in the original 10-way connector, the connector can be unplugged and taped back. Insert the 3 wires on the Satellite Radio overlay harness into the appropriate cavities of the 10-way connector that is supplied with the installation kit. (Item B). Then plug in the 10-way connector into the radio.

3.\*\* If the Vehicle has Rear Seat Entertainment, Pins 1, 2, and 6, must be extracted from the original 10 way connector, taped back / insulate; then the 3 wires from the Satellite Radio overlay harness can be inserted into the appropriate cavities of the original 10-way connector.

## 10A

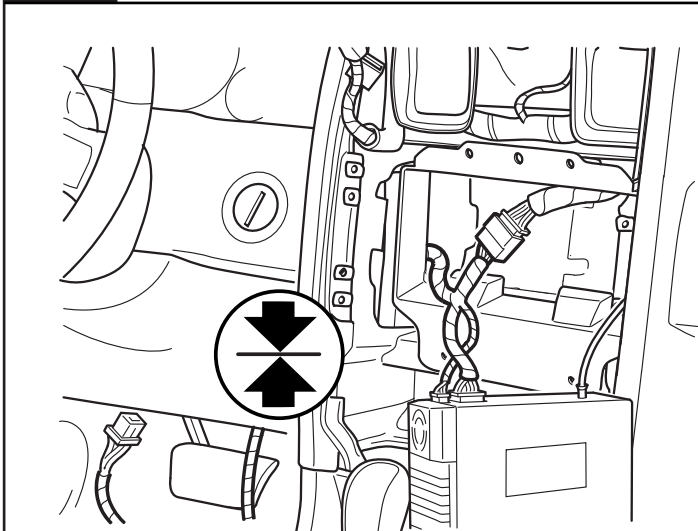

**11** Disconnect 22-way radio connector. Plug harness connectors in-between.

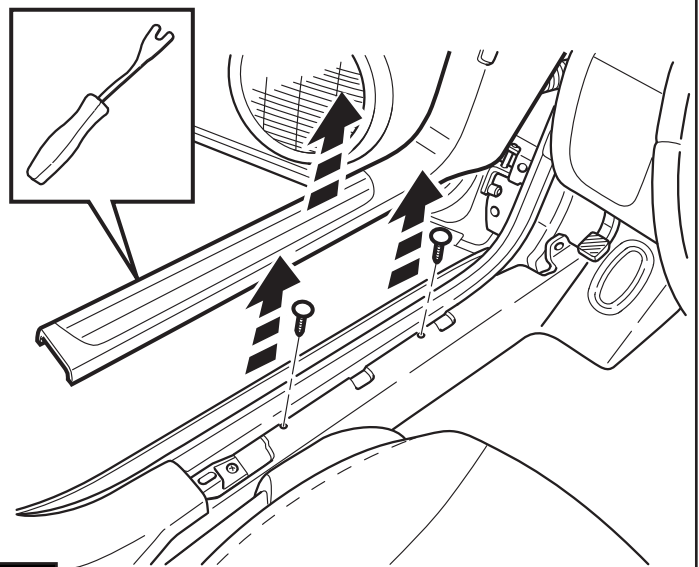

**12**

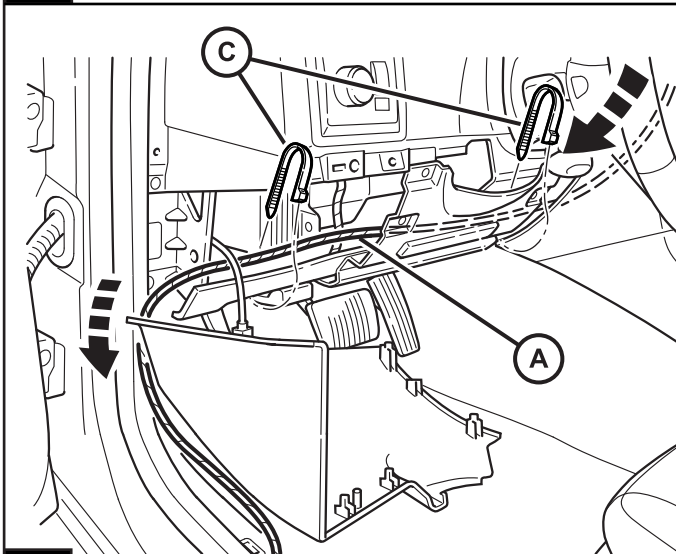

**13**

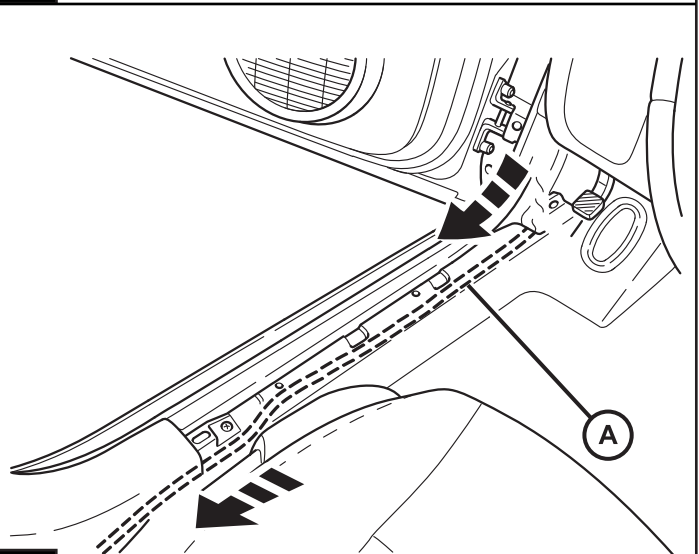

**14**

# CHRYSLER 300/DODGE CHARGER

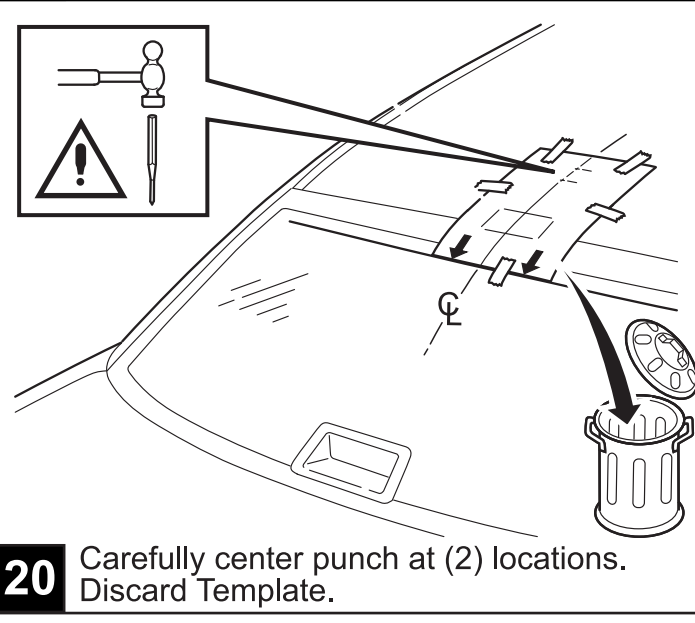
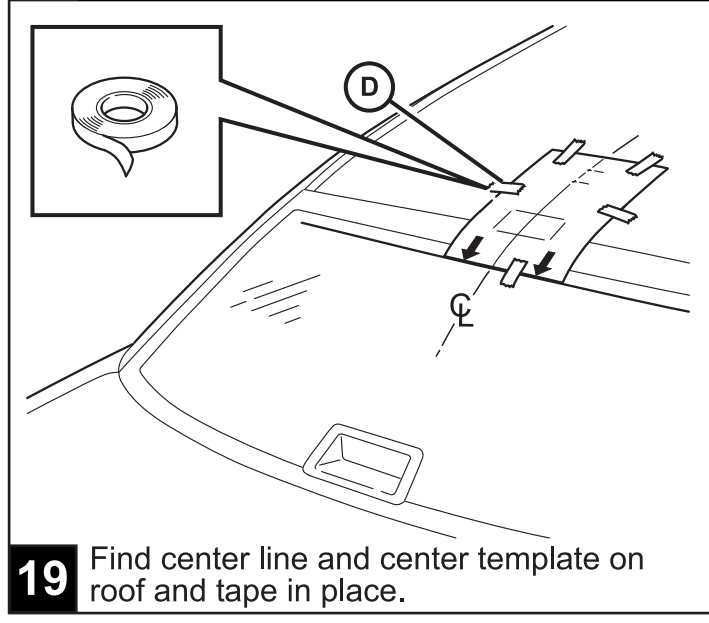
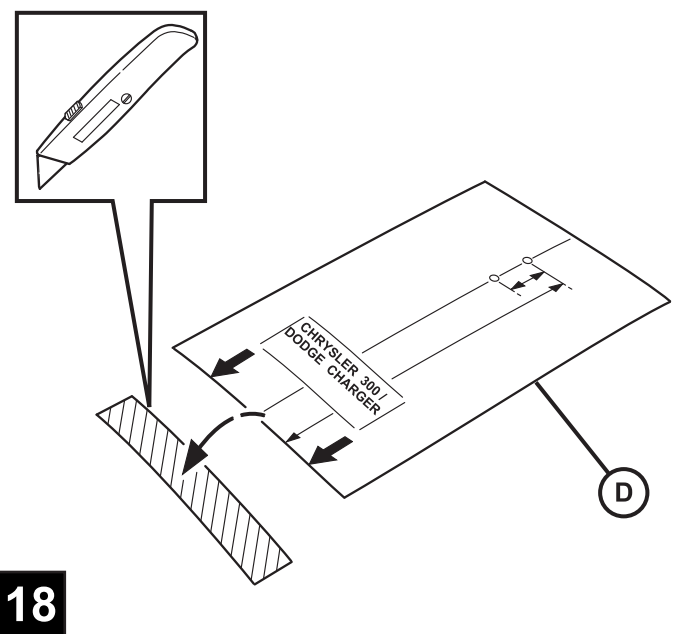
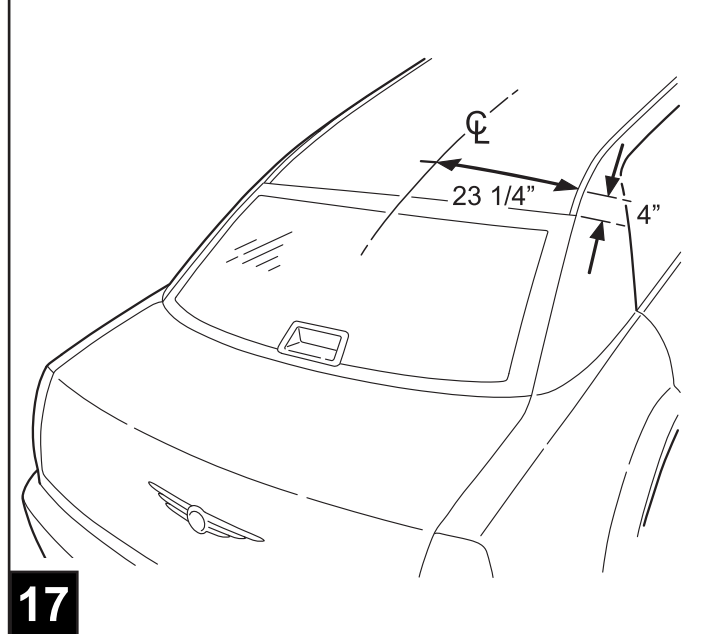
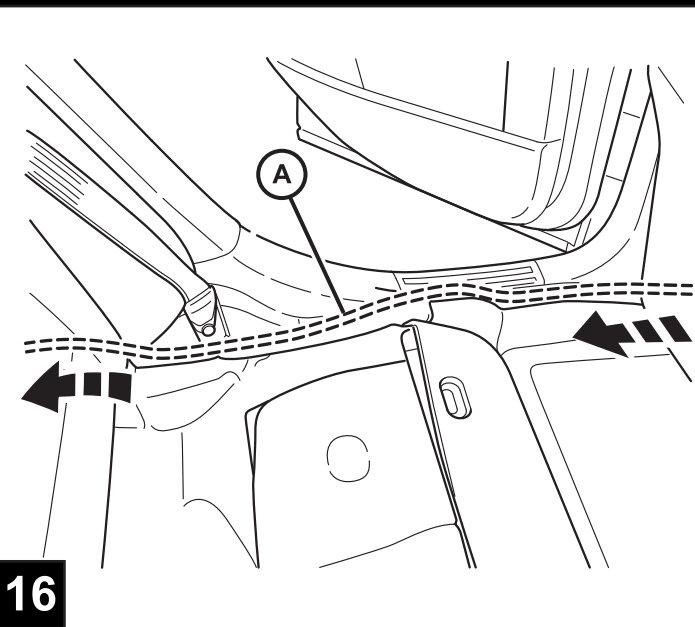
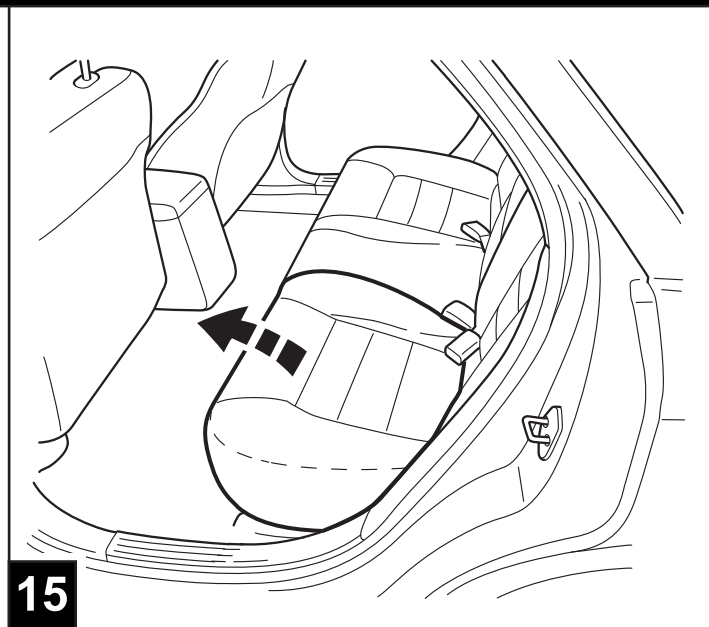

**19** Find center line and center template on roof and tape in place.

**20** Carefully center punch at (2) locations. Discard Template.



# CHRYSLER 300/DODGE CHARGER

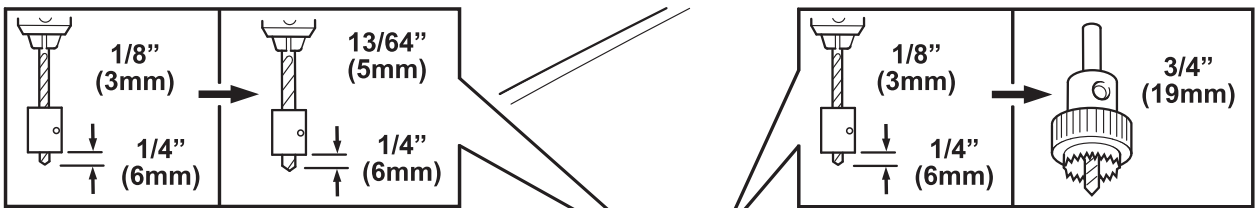

**21** Drill antenna mounting holes through the roof.

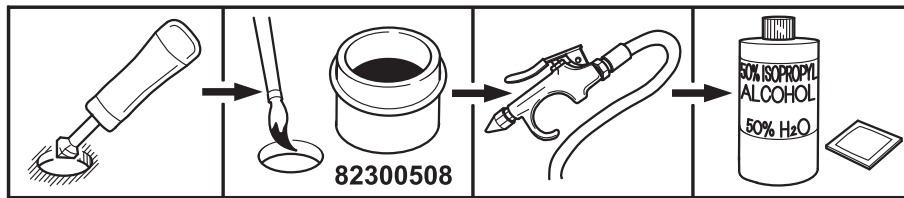

**22** Prep, prime, and clean the drilled holes.

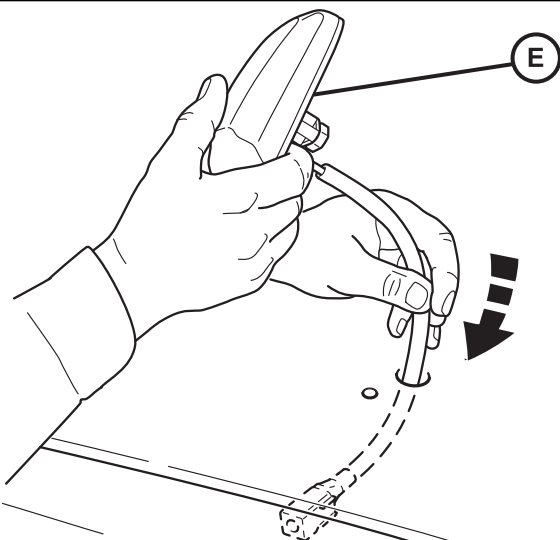

**23** Route antenna connector through holes.

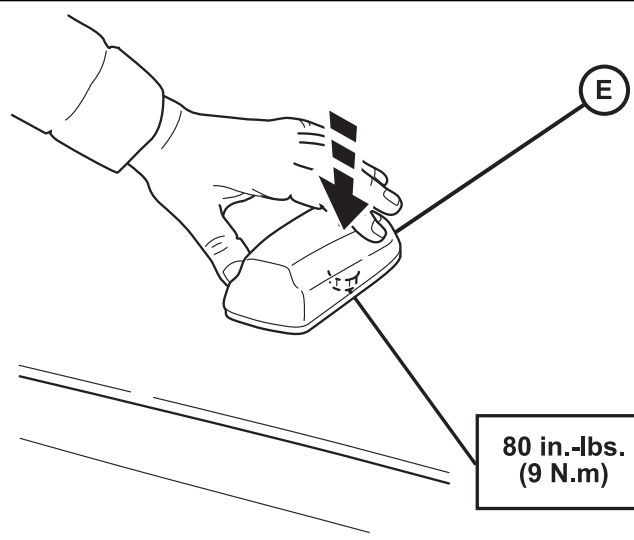

**24** Seat antenna to roof. Tighten mounting bolt to 80 in.-lbs. (9 N•m).

# CHRYSLER 300/DODGE CHARGER

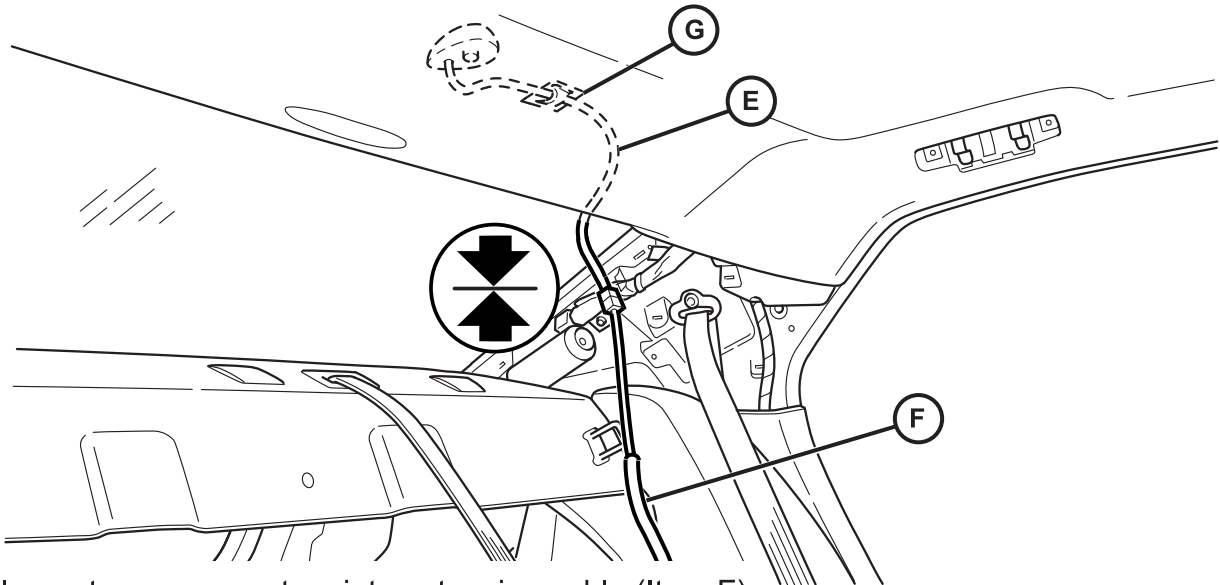

**25** Plug antenna connectors into extension cable (Item F)

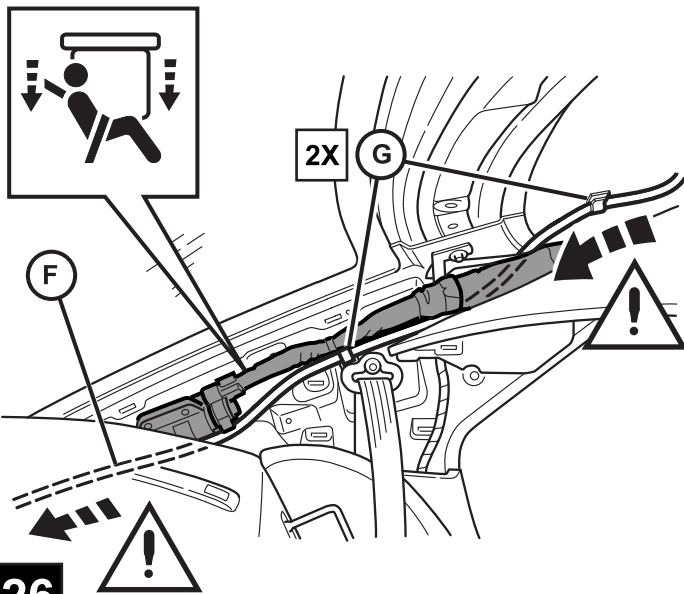

**26**

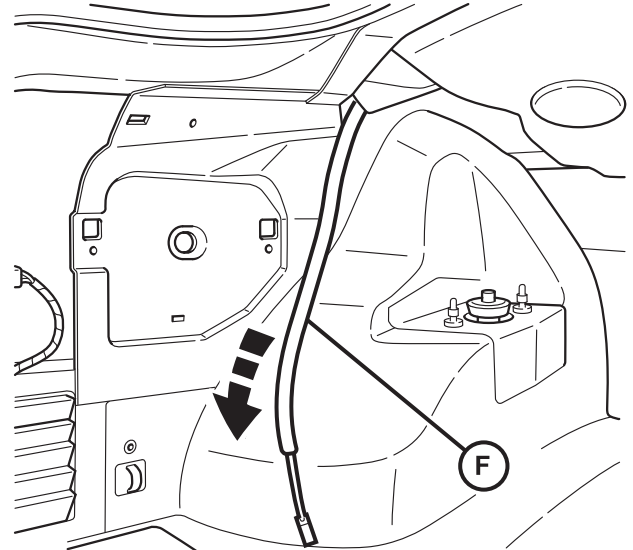

**27** Route extension cable into trunk.

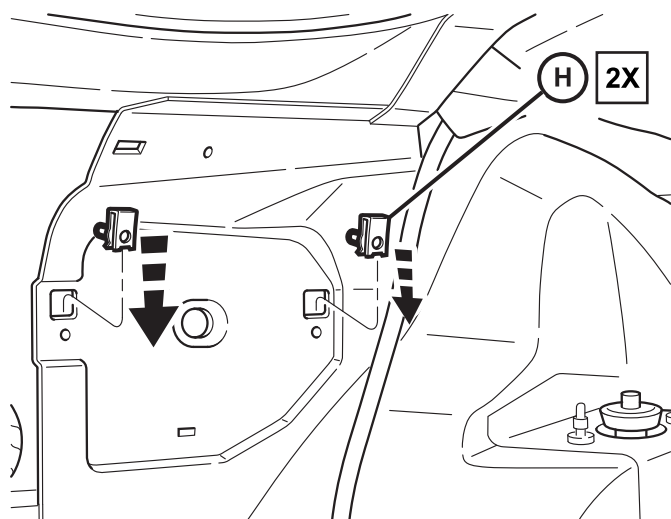

**28** Insert (2) u-nuts (Item H) over existing holes on quarter panel.

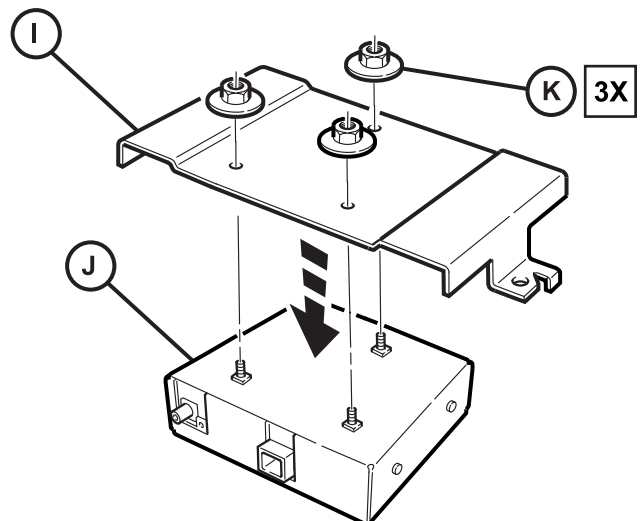

**29** Assemble bracket to receiver.

# CHRYSLER 300/DODGE CHARGER

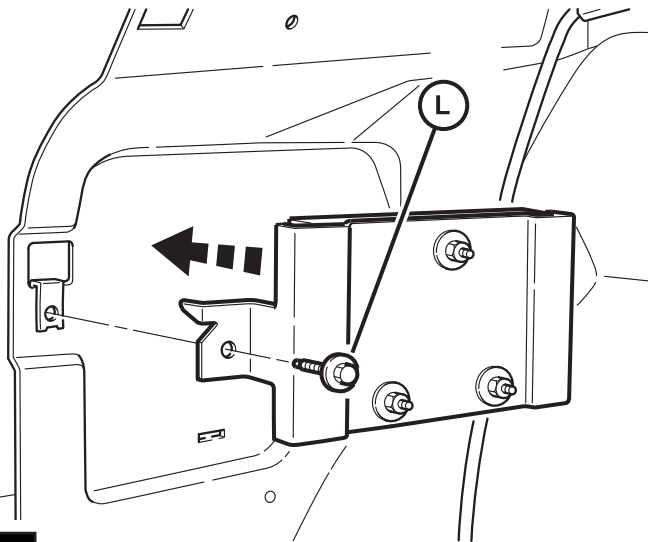

**30** Install receiver assembly.

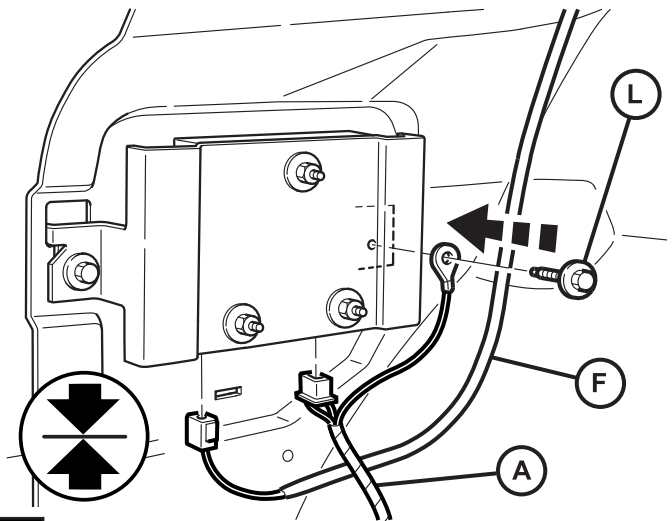

**31**

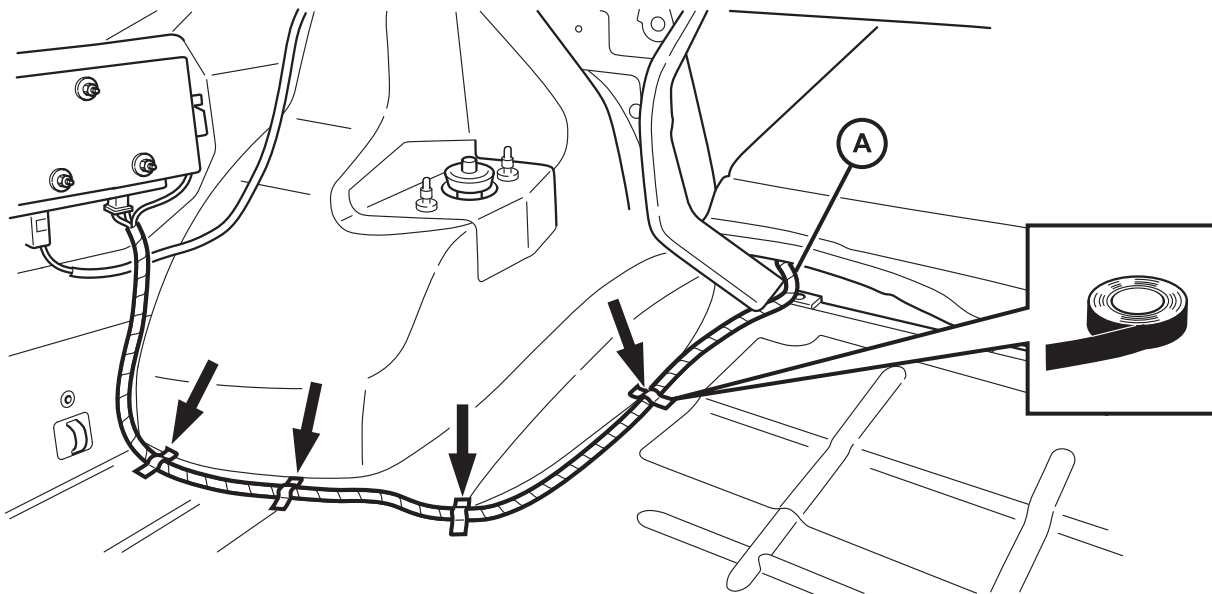

**32**

- Tie strap harness away from any sharp edges, heated, or moving parts.
- Re-install all previously removed panels, fasteners, and components.
- Ensure that cables are not pinched under trim panels.
- Re-connect battery.

**IMPORTANT:** Please affix ESN stickers to Owner's Manual, mirror tag and orange tag. Install mirror tag and attach orange card to invoice. (These items contained in receiver kit).

**33**



# CHRYSLER 300/DODGE CHARGER

Reconfigure the Front Control Module (FCM) by use of the STARSCAN diagnostic tool.

## FCM Reconfiguration Procedure

*IN THE INITIAL START UP SCREEN*

- PRESS -----
- TOGGLE DOWN AND HIGHLIGHT -----
- PRESS -----
- PRESS -----
- TOGGLE DOWN AND HIGHLIGHT -----
- PRESS -----

*FOLLOW ON SCREEN PROMPTS  
(I.E. CYCLE IGNITION KEY)*

- PRESS -----
- PRESS -----

**34**

- Drive vehicle outside to allow for a clear satellite signal to the antenna.

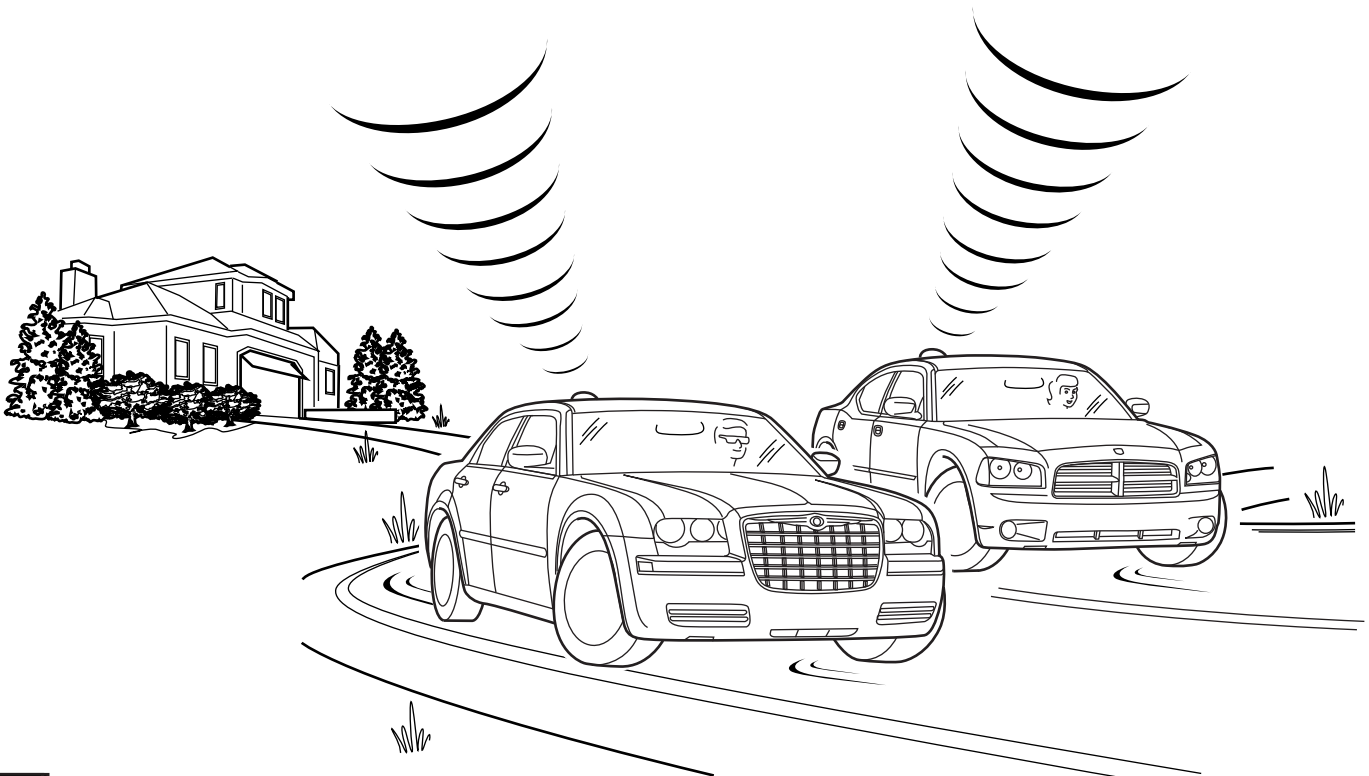

**35**

# DODGE MAGNUM

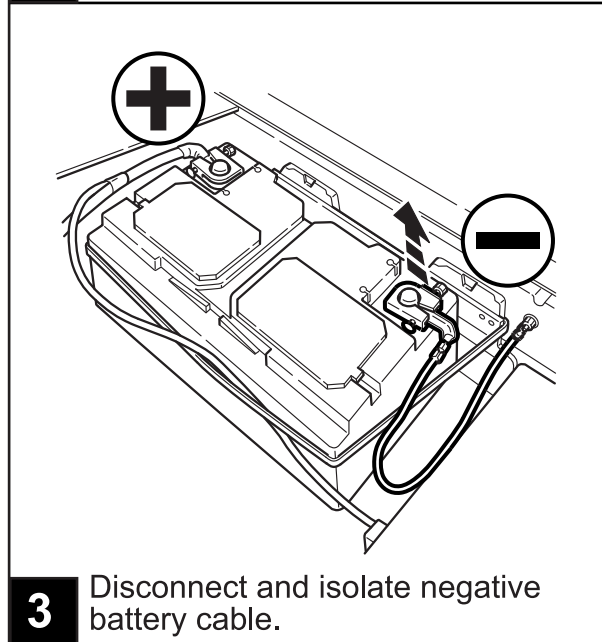
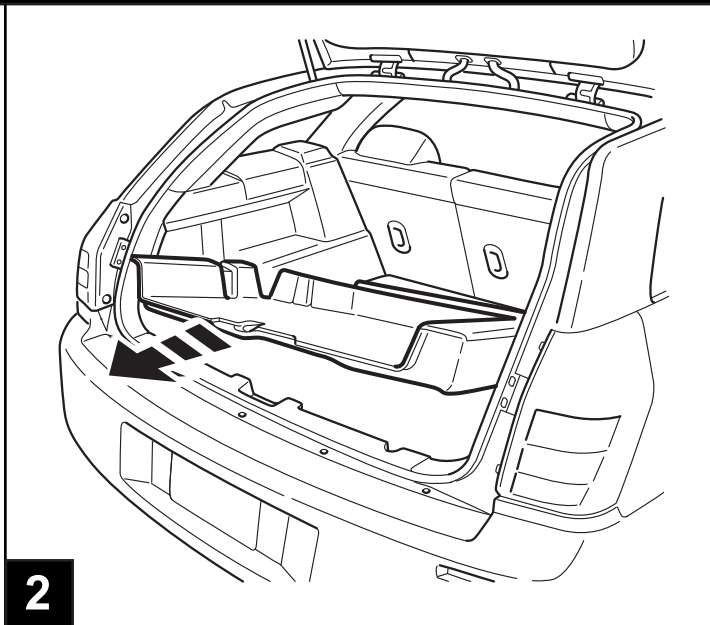
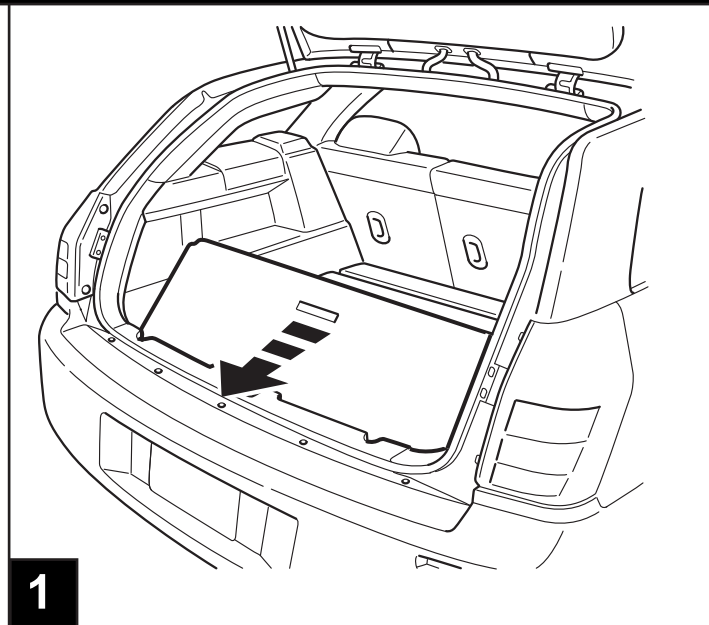

Disconnect and isolate negative battery cable.

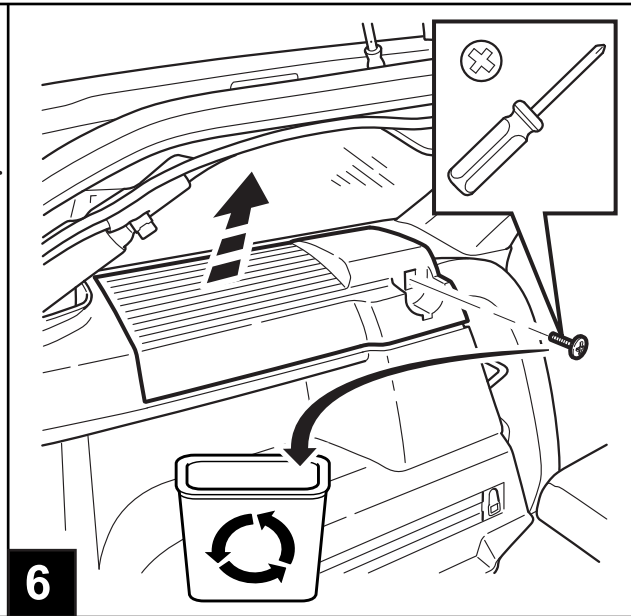
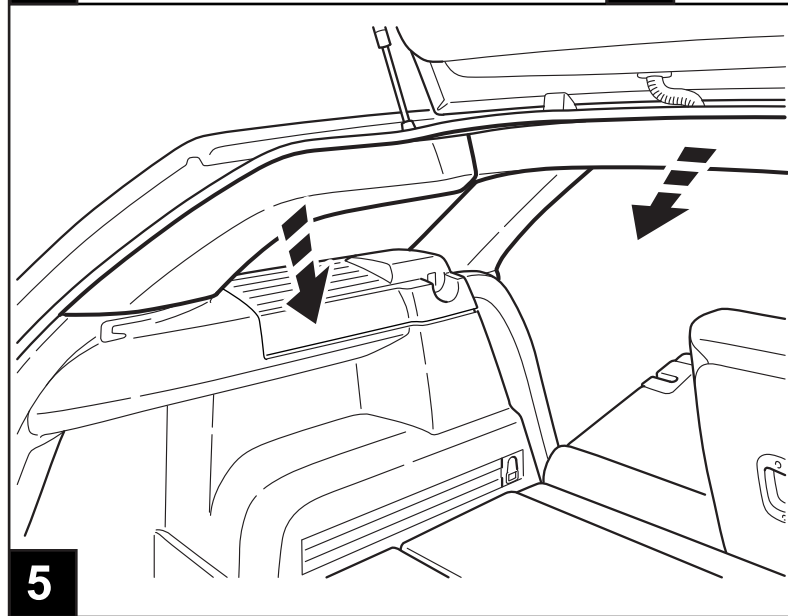
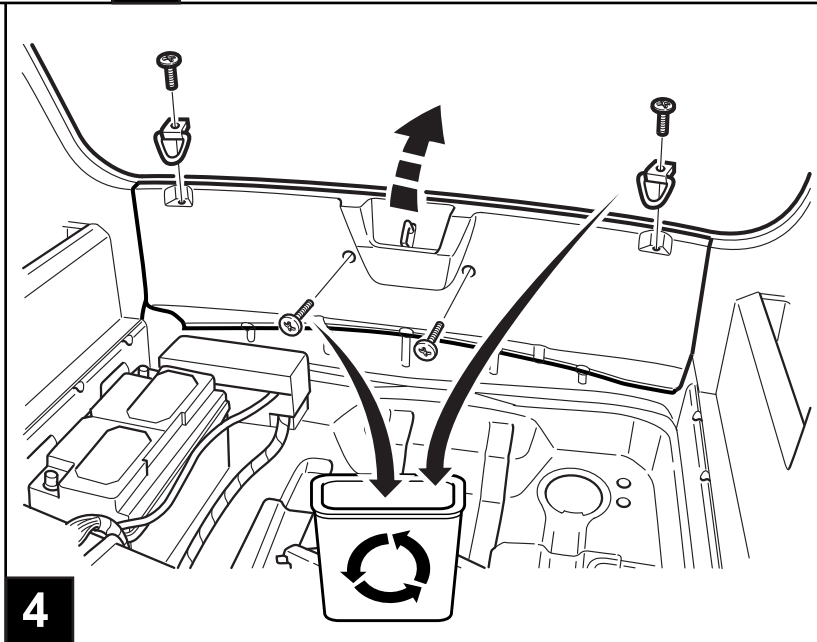

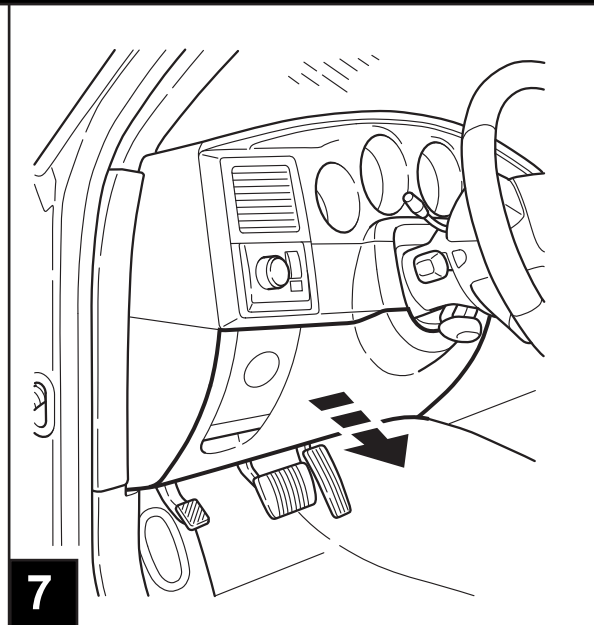

7

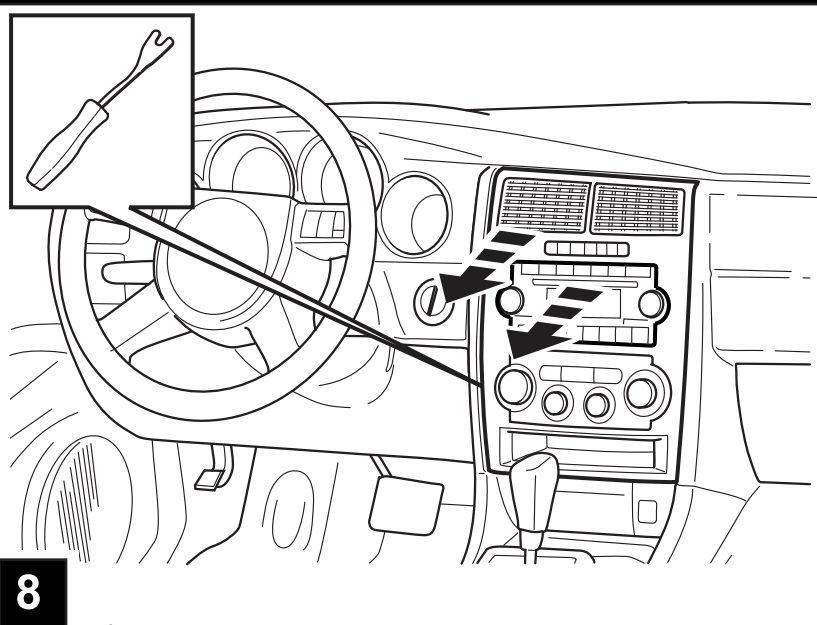

8

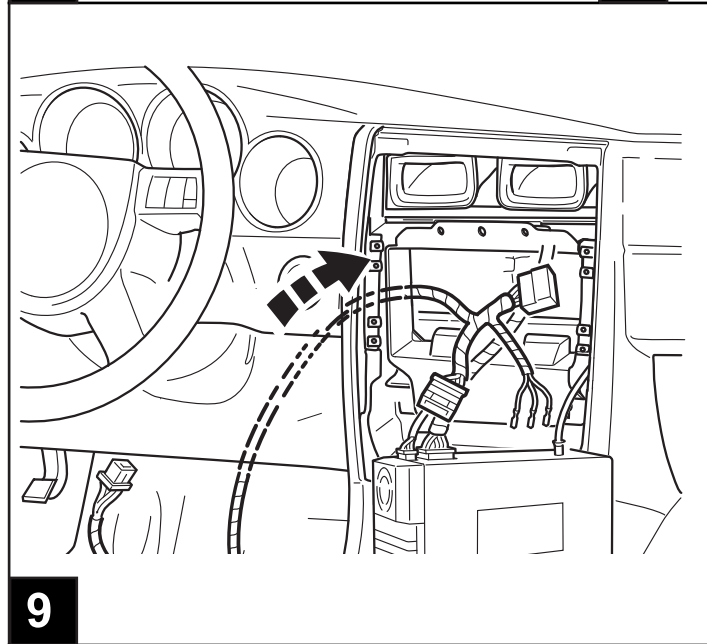

9

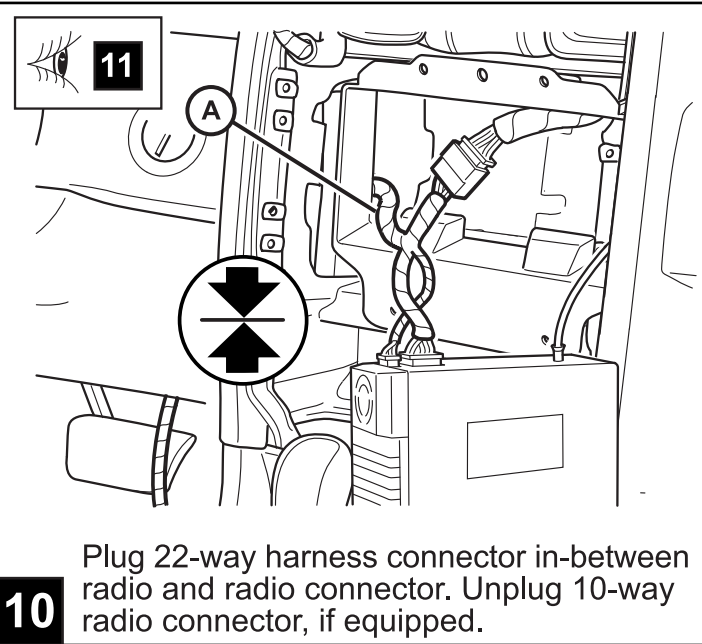

10

Plug 22-way harness connector in-between radio and radio connector. Unplug 10-way radio connector, if equipped.

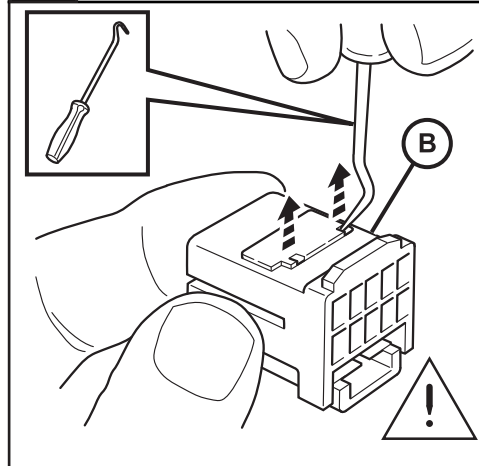

Lift up Only, Do Not Remove.

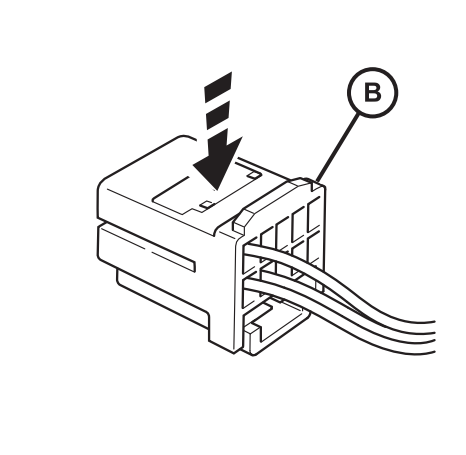
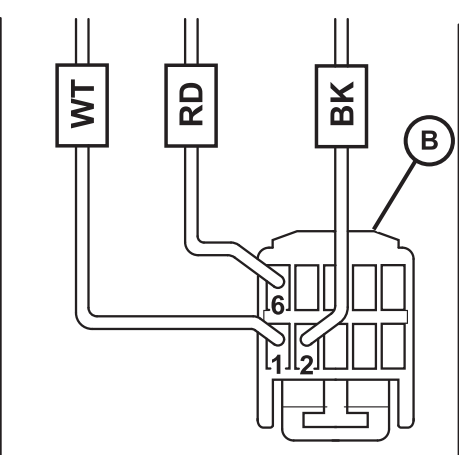

11

1. Plug and lock (3) harness wires into 10-way connector as shown. If radio does not have existing 10-way connector, use the one supplied in kit (Item K). In some vehicles there will be wires present in pins 1, 2, and 6 of the 10-way connector. See Step 11a.

# DODGE MAGNUM

- 2.\* If Pins 1, 2, and 6 are the only pins present in the original 10-way connector, the connector can be unplugged and taped back. Insert the 3 wires on the Satellite Radio overlay harness into the appropriate cavities of the 10-way connector that is supplied with the installation kit. Then plug in the 10-way connector into the radio.
- 3.\*\* If the Vehicle has Rear Seat Entertainment, Pins 1, 2, and 6, must be extracted from the original 10 way connector, taped back / insulate; then the 3 wires from the Satellite Radio overlay harness can be inserted into the appropriate cavities of the original 10-way connector.

**11A**

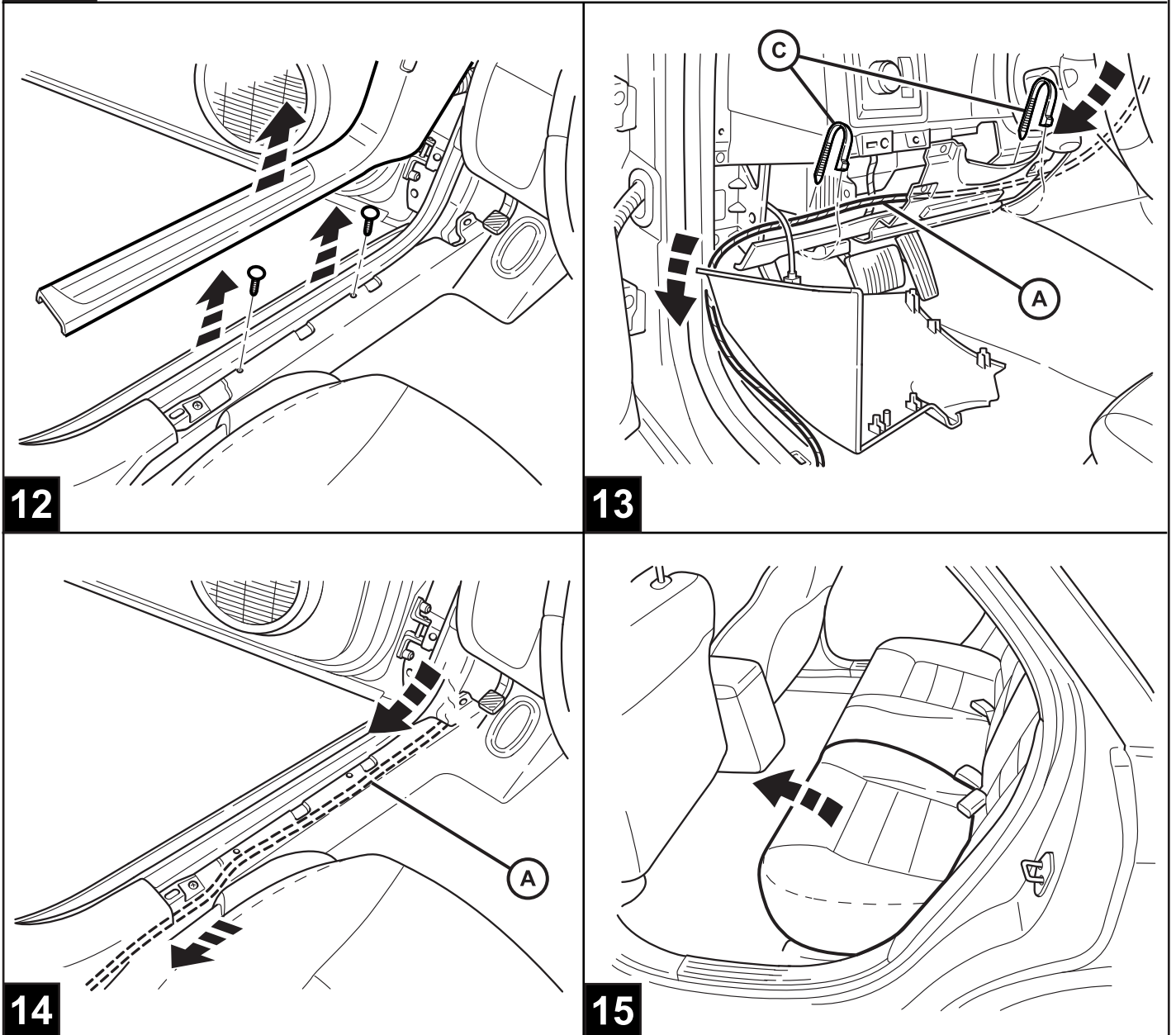

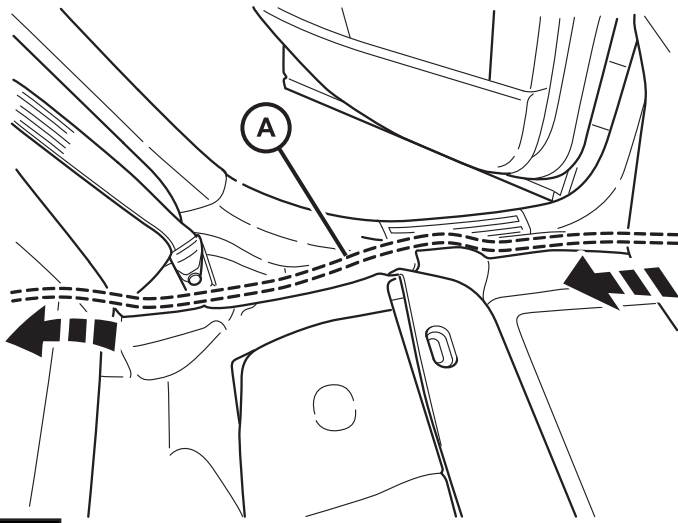

16

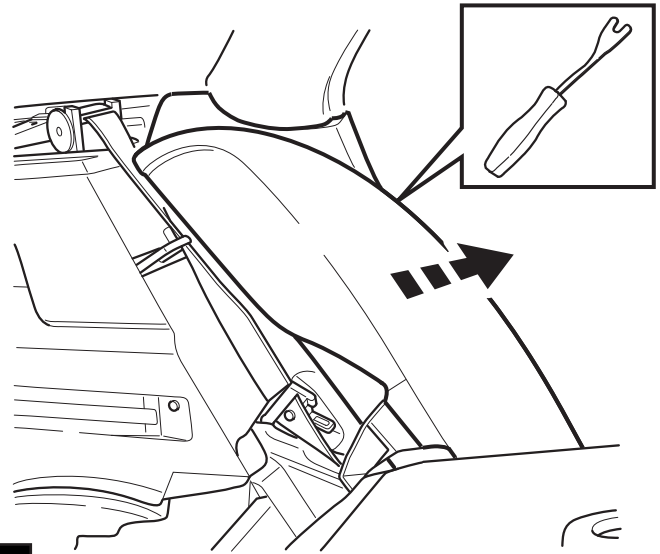

17

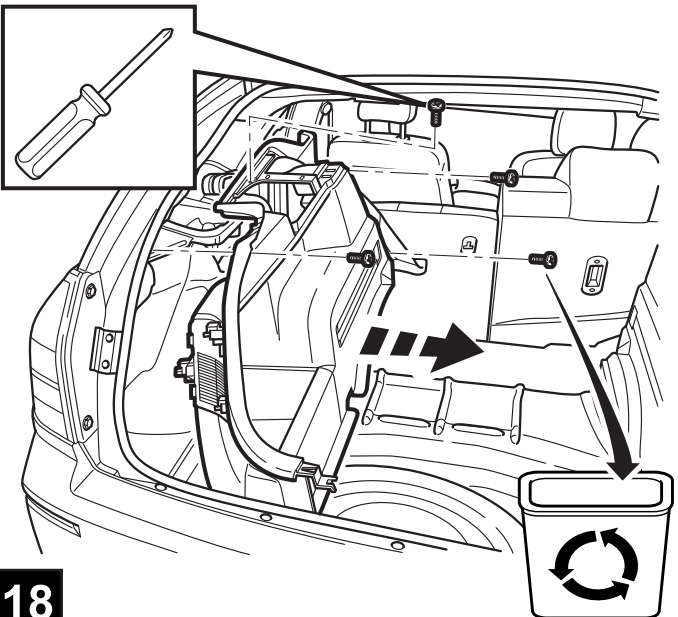

18

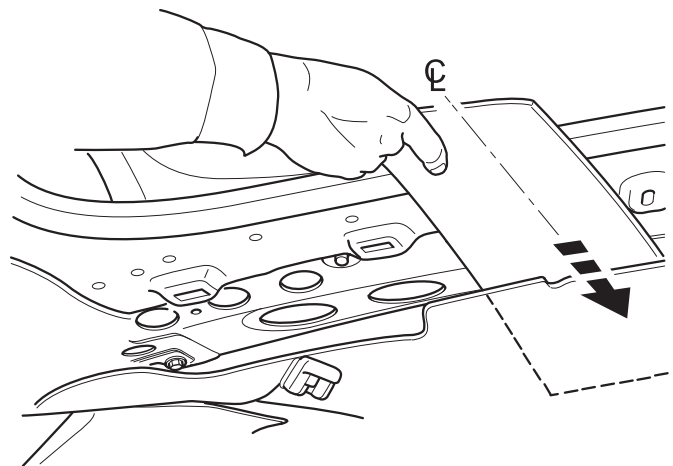

19 Insert scrap cardboard between headliner and roof to catch metal shavings.

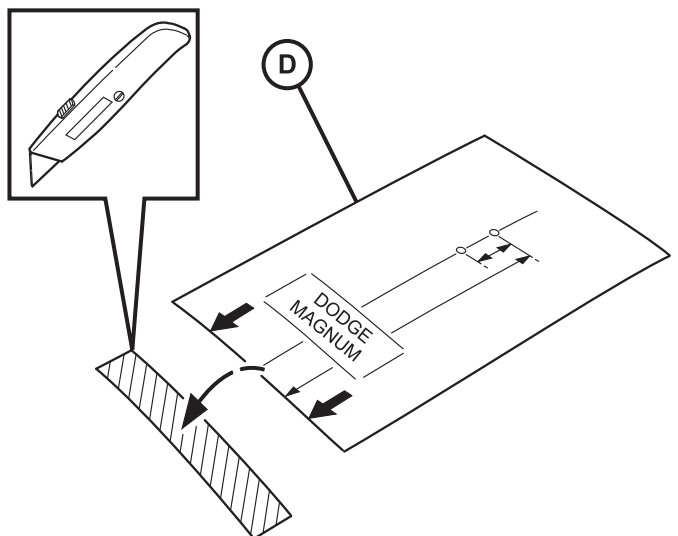

20

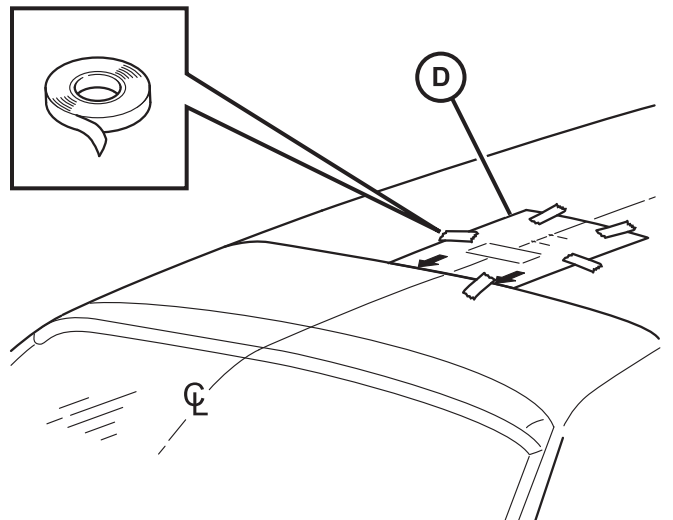

21 Find center line and center template on roof and tape in place.



# DODGE MAGNUM

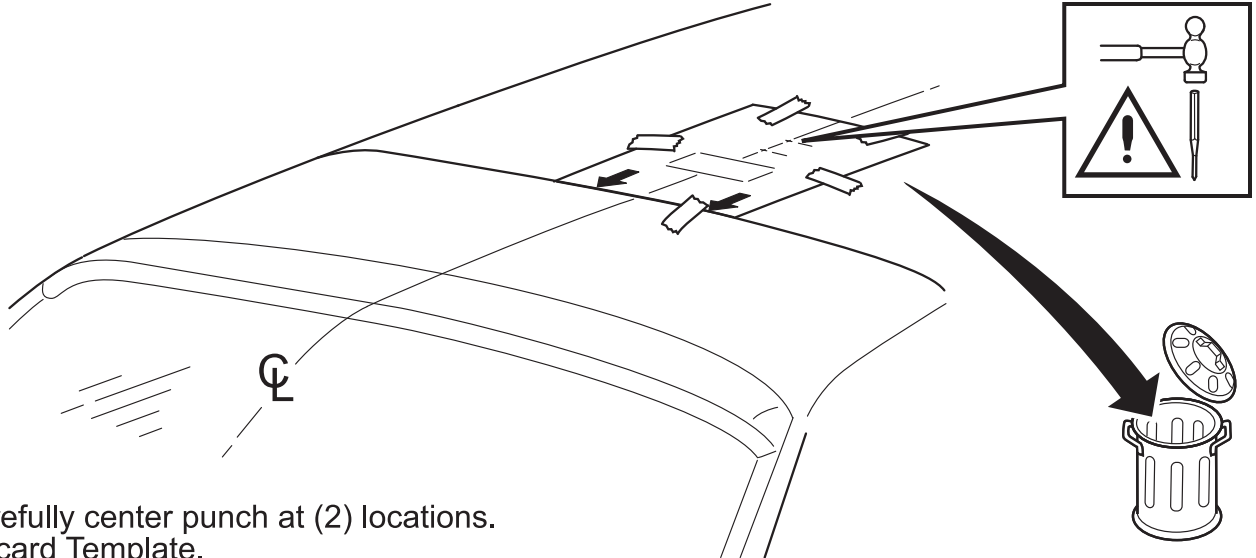

**22** Carefully center punch at (2) locations.  
Discard Template.

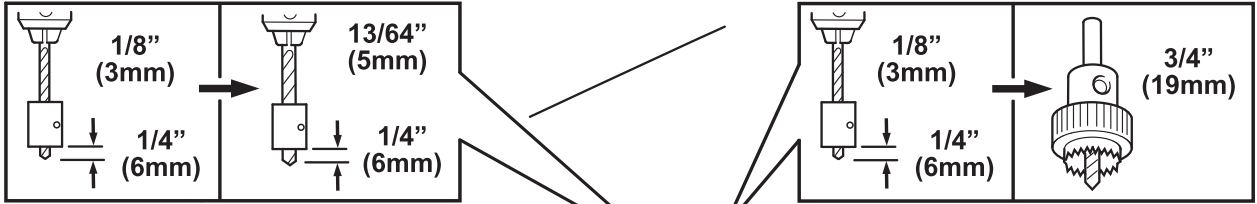

**23** Drill antenna mounting holes through the roof.

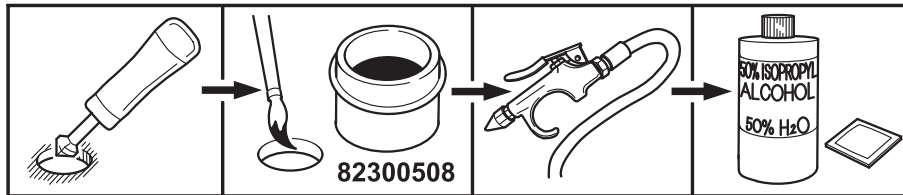

**24** Prep, prime, and clean the drilled holes.

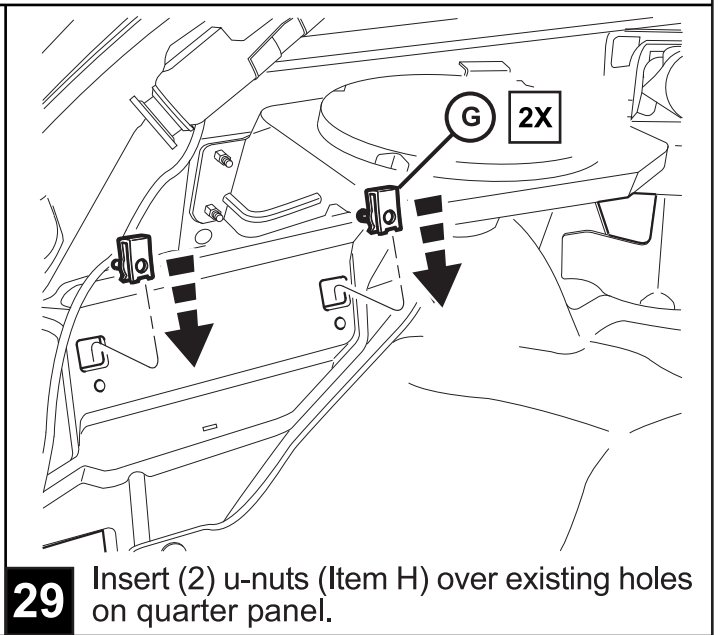
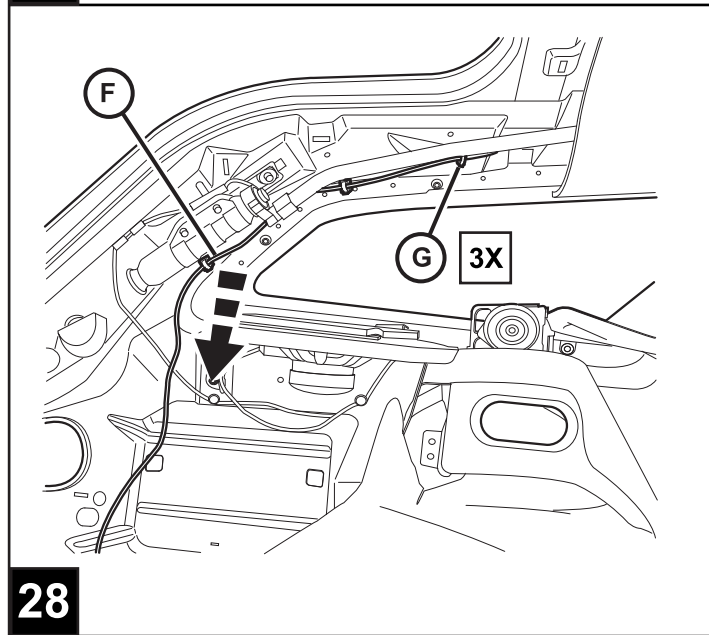
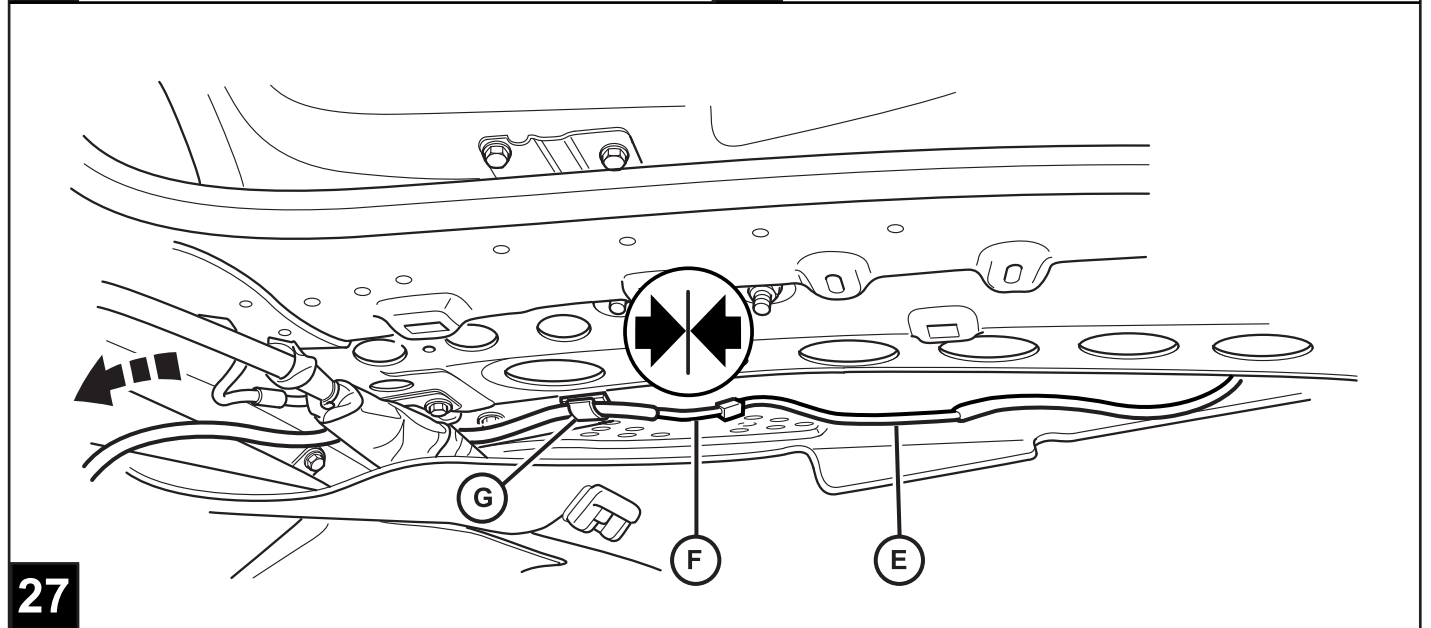
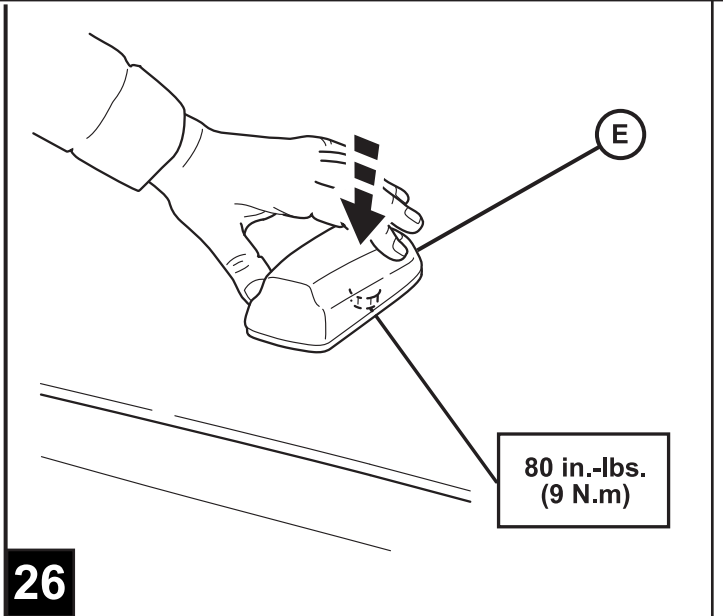
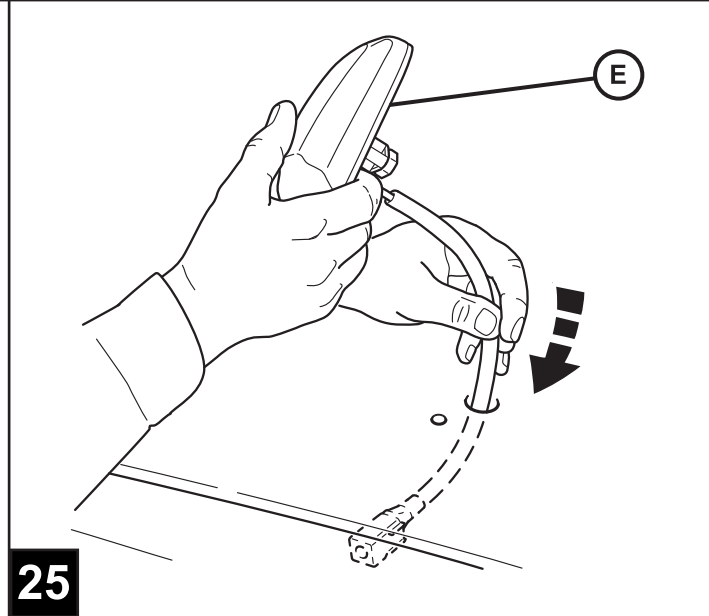

# DODGE MAGNUM

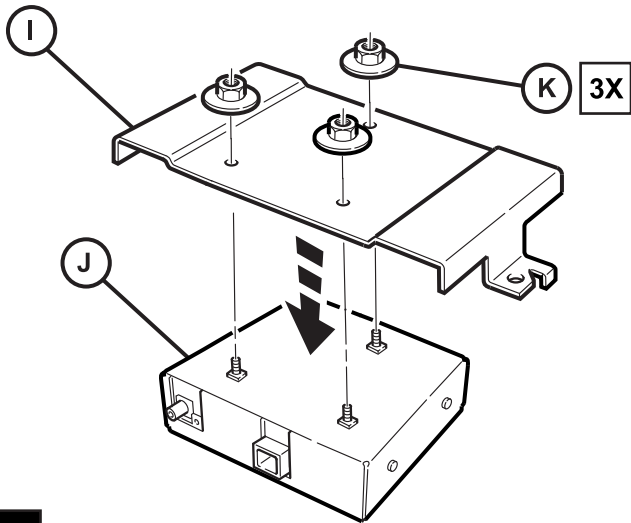

30

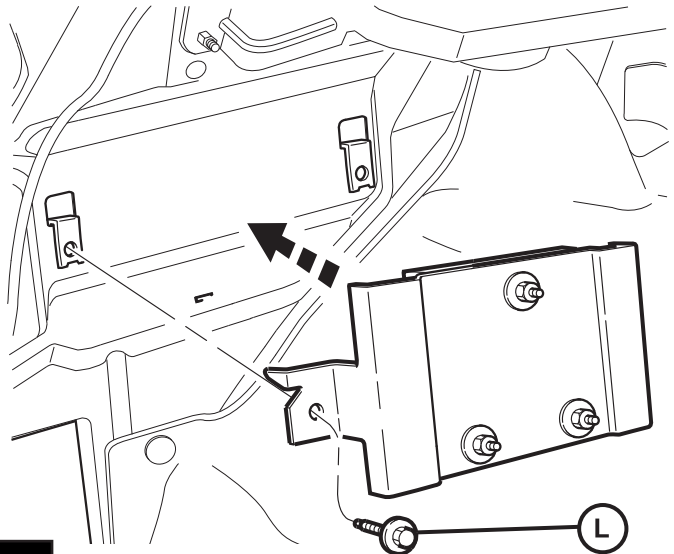

31

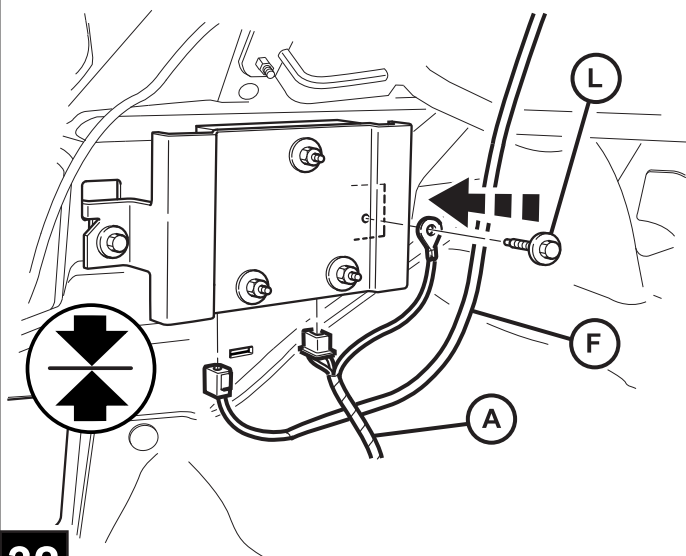

32

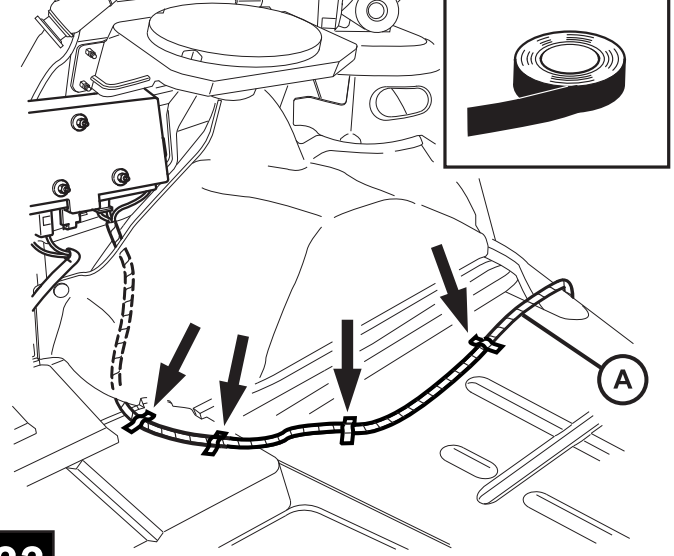

33

- Tie strap harness away from any sharp edges, heated, or moving parts.
- Re-install all previously removed panels, fasteners, and components.
- Ensure that cables are not pinched under trim panels.
- Re-connect battery.

**IMPORTANT:** Please affix ESN stickers to Owner's Manual, mirror tag and orange tag. Install mirror tag and attach orange card to invoice. (These items contained in receiver kit).

34

Reconfigure the Front Control Module (FCM) by use of the STARSCAN diagnostic tool.

## FCM Reconfiguration Procedure

*IN THE INITIAL START UP SCREEN*

- PRESS -----
- TOGGLE DOWN AND HIGHLIGHT -----
- PRESS -----
- PRESS -----
- TOGGLE DOWN AND HIGHLIGHT -----
- PRESS -----

*FOLLOW ON SCREEN PROMPTS  
(I.E. CYCLE IGNITION KEY)*

- PRESS -----
- PRESS -----

**35**

- Drive vehicle outside to allow for a clear satellite signal to the antenna.

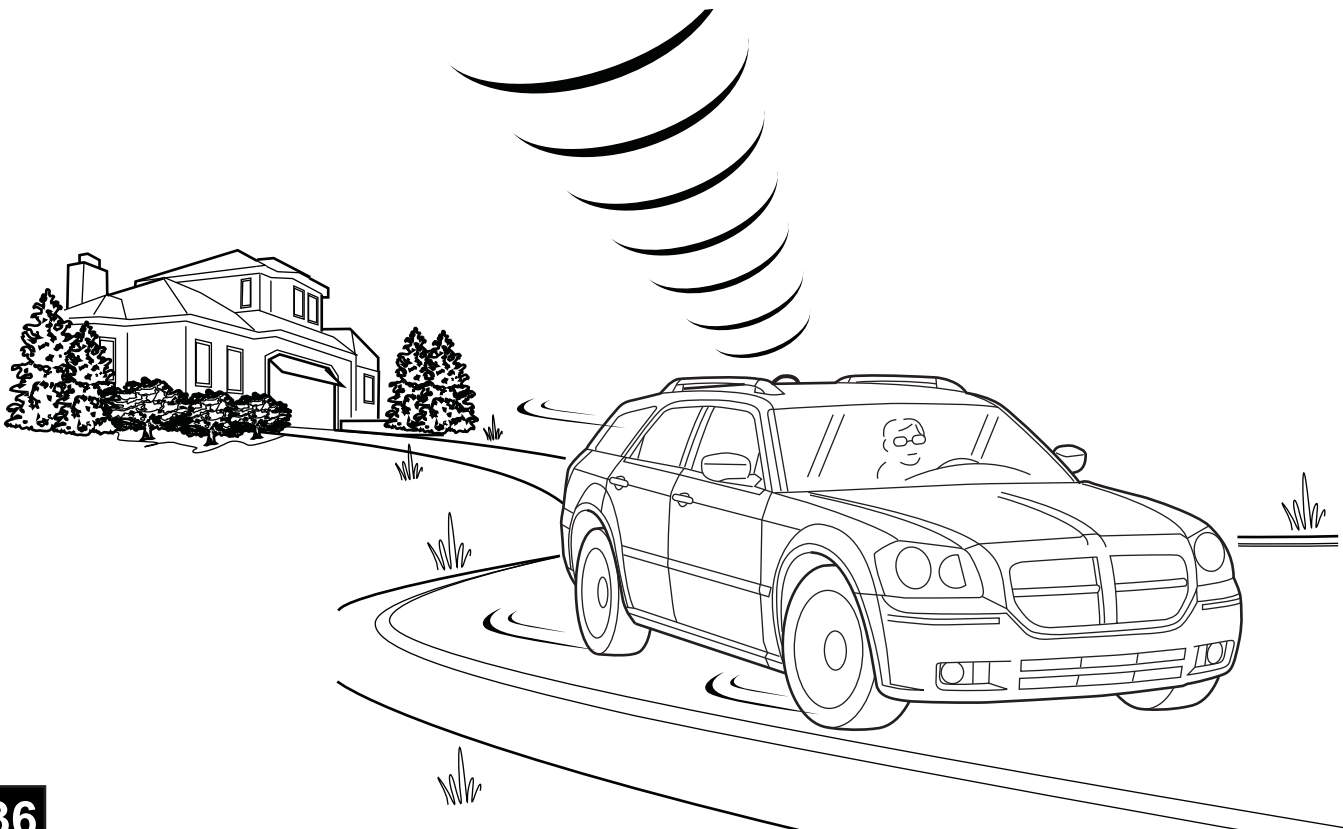

**36**