

# SHIFNOID WIRING DIAGRAM

FOR B&M PRO STICK, TCI OUTLAW OR THUNDER STICK SHIFTER  
with a SN5055B THREE SPEED SOLENOID KIT

IF YOUR RPM SWITCH OR TIMER SUPPLIES "NORMALLY OPEN GROUND"  
(SHIFNOID OR MSD) USE THIS DIAGRAM

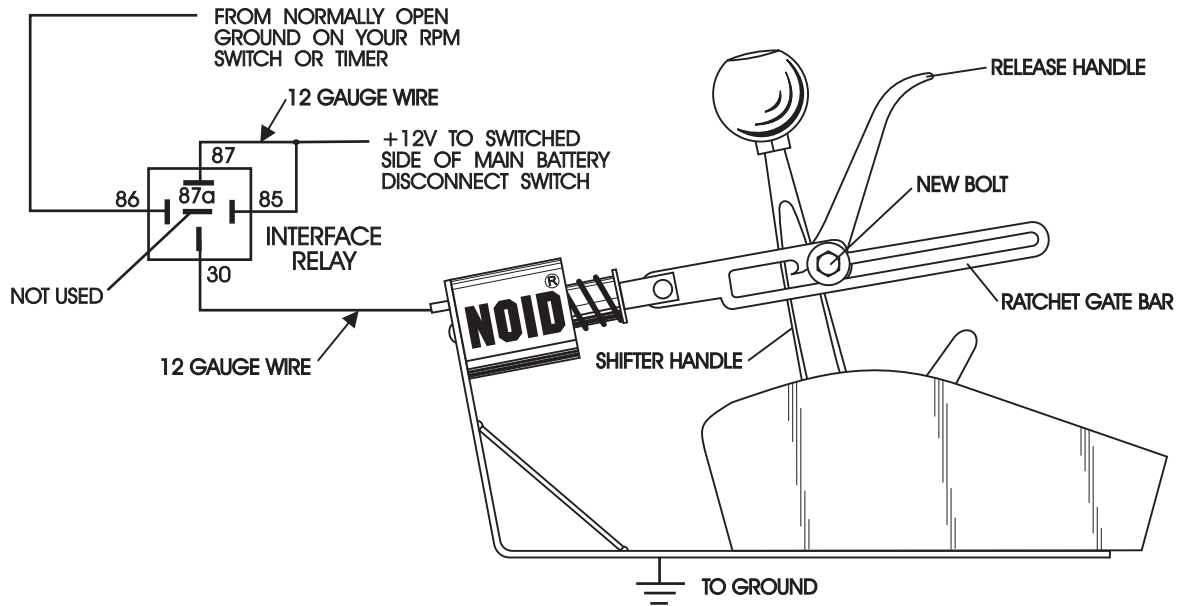

IF YOUR RPM SWITCH OR TIMER SUPPLIES "NORMALLY OPEN +12V"  
(DEDENBEAR OR DIGITAL DELAY) USE THIS DIAGRAM

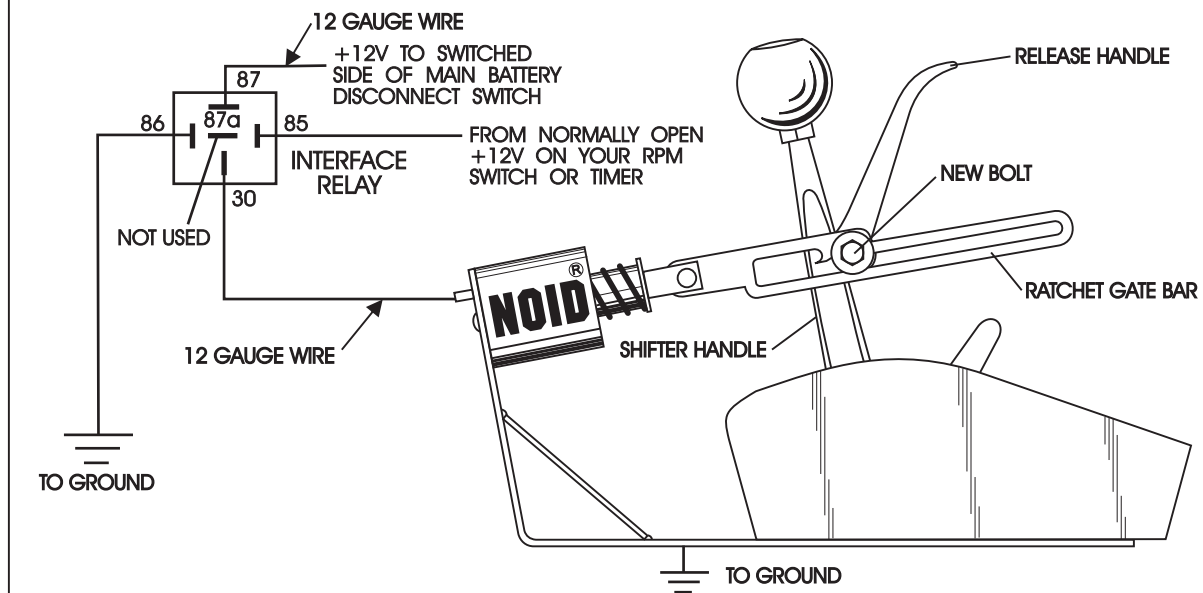

# SHIFNOID SEQUENCE DIAGRAM

FOR B&M PRO STICK, TCI OUTLAW OR THUNDER STICK SHIFTER  
with a SN5055B THREE SPEED SOLENOID KIT

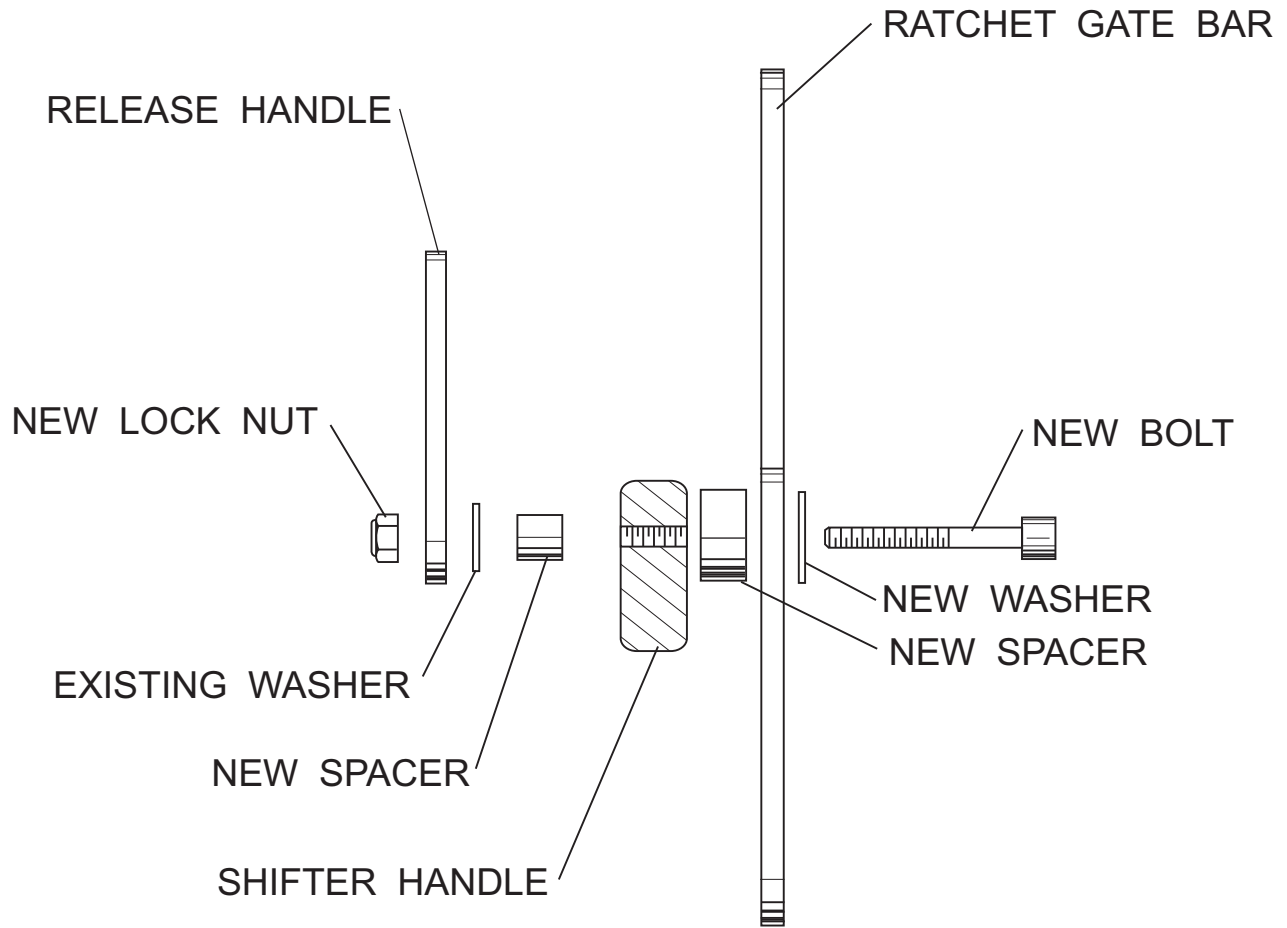

TOP VIEW

# **INSTALLATION INSTRUCTIONS**

## **“SHIFNOID” AUTO SHIFTER SOLENOID KIT**

### **PART # SN5055B**

FOR REVERSE PATTERN 3 SPEED TRANSMISSIONS USING  
“B & M” PROSTICK<sup>tm</sup>, TCI OUTLAW OR TCI THUNDER STICK SHIFTERS  
1ST TO 2ND & 2ND TO 3RD SHIFT

#### **MODIFYING YOUR SHIFTER**

Due to the style of shifter you will mount this kit to, it will be necessary to grind off the block or ramp on the gate of your shifter where the safety handle engages. Do this only to the spot on your gate that stops the shifter handle from going from 2nd to 3rd gear. This will eliminate squeezing the handle on the shifter between 2nd and 3rd. You can accomplish this by buying the opposite pattern shifter than your transmission pattern. For a reverse pattern transmission, buy a forward pattern shifter, or grind the gate as explained. You can also make this change on these shifters by replacing the gate that came on your shifter with the gate for the opposite shift pattern. Some shifters come with both gates. If you have a reverse pattern shifter, install a forward gate. This eliminates any grinding and is relatively inexpensive and easy to do. Grinding on or changing your gate will allow your shifter to shift from 1st, directly to 3rd, if the handle is pulled or hit with sufficient force. When shifting by hand, such as in a burn out, you will need to shift gently, using the feel of the detent in your transmission as your guide for shifting from 1st to 2nd.

#### **MOUNTING THE UNIT**

The SHIFNOID mounting bracket is drilled for all models of 3 speed shifters listed. Bolt the bracket between the shifter and the mounting surface (floor, shifter platform, etc). Bolt the bracket down using the slots that correspond with your shifter, but do not tighten at this time. These slots are oversize so that alignment may be done before final tightening. Following the supplied diagram, remove the bolt and washer that holds the squeeze or release handle to your shifter. This bolt is replaced with the supplied bolt, washers, and spacer. Follow the sequence shown in the diagram when attaching the ratchet gate bar to the shifter handle. The supplied bolt passes through the washer, gate, then large spacer. The bolt then threads into the hole on the opposite side of the handle that the original bolt was removed from. The small spacer slides over the bolt threads protruding through the handle. Replace the original washer and handle. The lock nut supplied will hold the release handle in place. Take care to insure that this assembly is not over tightened when installed. Over tightening could cause your release handle to bind when squeezing. With sufficient clearance, so ratchet bar can slide easily, hold the bolt and tighten the lock nut. This will hold the bolt position in place. It may be necessary to shift the bracket back to front or from side to side for proper alignment before tightening your mounting bolts. If the bracket “picks up” in the back when the solenoid fires, the load to shift is greater than normal and you may need to bolt the bracket down in the back, inside the gusset. The placement of the ratchet gate bar in relationship to the bolt it pulls is critical. If the ratchet gate is too far forward, the solenoid may not pull your shifter fully in to the next gear. If the ratchet gate is back too far, the solenoid may pull your shifter from 1st to 3rd gear. Most shifters will require an approximate 3/16” gap between the “hook” on the ratchet bar and the bolt. This will give the solenoid the ability to travel a sufficient amount to gather force before the ratchet bar tries to move the shifter handle.

## **WIRING THE UNIT**

Follow the wiring diagram supplied. If your RPM switch or Timer supplies a "Normally Open Ground" connect the trigger wire from your device to post 86 on the relay. Supply post 87 and 85 with 12V+, with a 12 gauge wire. Connect post 30 to the solenoid.

If your RPM switch or Timer supplies a "Normally Open 12V" connect the trigger wire from your device to post 85 on the relay. Ground post 86. Supply post 87 with 12V+, with a 12 gauge wire. Connect post 30 to the solenoid.

**DO NOT CONNECT THIS UNIT DIRECTLY TO AN RPM SWITCH OR TIMER. ALWAYS USE THE INTERFACE RELAY. THE RPM SWITCH OR TIMER MAY BE DAMAGED IF CONNECTED DIRECTLY.**

## **USING THE UNIT**

When ready to race, simply place your shifter in first gear. The RPM switch or push button you are using to activate this unit will send a signal to the relay which in turn will fire the solenoid, causing it to pull backwards. This will cause the ratchet bar to pull on the shifter handle, shifting into second gear. As soon as the switch releases, the solenoid will return the ratchet bar to the ready position, grabbing the handle for the next shift. When the switch is again activated, the solenoid will pull the handle into third gear. When you are ready to return the shifter to low gear, or down shift, simply lift the ratchet bar with your little finger as you are squeezing the release handle on your shifter.

## **WARNING**

Be Prepared! If you are using an RPM switch or Timer, you must be aware that at any time RFI (Radio Frequency Interference) could stop your RPM switch or Timer from activating. This in turn could cause your automatic shifter to not activate and you will need to shift manually. Always pay attention to your car and be prepared to manually shift or lift off of the accelerator to prevent the over revving of your engine. One of the best ways to protect your engine under these conditions is to also install some type of over rev control so that the engine cannot reach an RPM beyond it's safe limits. Please read the enclosed information on RFI included with this kit.

## **QUESTIONS?**

If you have questions or concerns on the installation or use of this product, do NOT contact the retailer where you purchased the kit. Most retailers are not equipped to help you with in depth tech questions.

SHIFNOID LTD. has arranged for all tech and warranty to be handled by it's distributor:

CONTENDER PERFORMANCE PRODUCTS INC.  
Phone: 740-927-0060 [www.contenderperformance.com](http://www.contenderperformance.com)

# TROUBLESHOOTING AND TECHNICAL SUPPORT

## SHIFNOID

### SN5055B AND SN5055H

### ELECTRIC SHIFT KIT

**PROBLEM:** THERE ISN'T ENOUGH POWER TO PULL THE SHIFTER HANDLE ALL THE WAY BACK

#### IMPORTANT INFORMATION:

Be aware that the solenoid **THROWS** the shifter into gear. It does not **PULL** it fully into gear. Therefore, there is a difference between activating the solenoid by hand and electrically firing it. When testing by hand, if the ratchet bar only pulls the handle most of the way, be aware that it is probably fine when electrically activated. If the ratchet bar pulls the handle all the way into gear when activated manually, it may over shift when electrically activated. Please keep this in mind when doing all adjusting on this model.

#### **SOLUTION:**

To determine why the solenoid can't pull the shifter handle fully into the next gear, you must first determine if the solenoid cannot pull the handle or if the load on the solenoid is too great. Without proper testing equipment, the only way to determine this, is by process of elimination. Many times, there are multiple problems that total up to an inoperable system. You must verify and fix them all to correct this condition. Please follow all steps listed below.

**STEP ONE:** To confirm that the solenoid has full power, verify that the wire connected to post 87 on the interface relay is 12 gauge or larger, and runs directly to a suitable 12 volt power source, (i.e. master battery disconnect switch). This power source must be sufficient to supply a 25 - 30 amp draw. Do not connect this wire to any terminal or point that supplies other electrical devices.

**STEP TWO:** Confirm that the wire from post 30 on the interface relay to the solenoid is a 12 gauge or larger.

**STEP THREE:** The solenoid gets its ground from the SHIFNOID bracket. The SHIFNOID bracket typically receives a sufficient ground by bolting it to your floor. Many times, because of paint, powder coating, or mounting (such as a pinned in pedestal), the bracket will not receive a sufficient ground. This would cause a solenoid to receive insufficient amperage to have full power. If in doubt, add a ground wire to your shifter or SHIFNOID bracket and to a good chassis ground.

**STEP FOUR:** The relationship of the hook or tooth on the ratchet bar you placed in the side of the shifter handle is critical. An electric solenoid is simply a large magnet that is trying to pull the plunger, (the gold hat shaped piece), back into the solenoid. If the plunger meets resistance too soon, the solenoid will have no power. Therefore, there must be a gap between the hook on the ratchet bar and the shoulder bolt of approximately 3/16 inch. This cannot be seen because of the large spacer and silver washer, but can be felt by pulling back on the plunger by hand. The plunger and, consequently, the ratchet bar should travel approximately 3/16 inch before it contacts the shoulder bolt and tries to move the shifter handle. This adjustment is achieved by sliding the entire SHIFNOID bracket forward or backward in relationship to your shifter. The tighter the load, the greater the gap will need to be, to a maximum of 1/4 inch. The lighter the load, the smaller the gap can be, never less than 1/8" inch. The preceding steps will verify that the SHIFNOID system is up to full power.

Next, you must check for an excessive load beyond what the SHIFNOID is capable of activating. If the SHIFNOID system is producing full power, and the handle is still not moving correctly, verify that there is not excessive shifter cable bind. There must be no bend or pressure on the first several inches of the cable. See shifter instructions. Cable routing must include large, gradual bends. Any tight bends or kinks will create a load greater than the SHIFNOID can pull.

**PROBLEM**

THE SOLENOID WILL ONLY SHIFT FROM 1ST TO 2ND

**SOLUTION**

The solenoid is a simple electrical appliance. It can only be turned on and off if activated and deactivated. It cannot stay on or turn off without your RPM switch or timer activating it. There are two possible reasons for this problem.

STEP ONE: The most common scenario is a car whose RPM's do not drop sufficiently between shift points. Most RPM switches require a drop of 400 to 500 rpms to turn off. Example: This means that if you shift at 6000 rpms, and because of clutch wear, tire spin, or your converter not locked up, the drive train (everything from the flex plate back), cannot drag the engine down because of slippage, the RPMs do not drop below 5500 and your RPM switch, in effect, tells the solenoid to stay on. This will result in the solenoid pulling the shifter handle from 1st to 2nd and locking back. Shifting before your converter is locked up is the most common problem. Converter stall speed is rarely where advertised. The following simple test may confirm this. Raise your shift point as high as you safely can. If this solves the problem, consider tightening the converter. If the problem persists, raising your shift point can cause transmission clutch slippage to worsen, if they are worn, and may even increase the problem. Some types of racing, such as mud, dirt, or sand drags, result in tire spin that cannot be eliminated. When this is the case, special electronic controllers are available to solve the problem. Please ask your SHIFNOID dealer for assistance.

STEP TWO: Another common problem is the electrical solenoid shifting from 1st to 2nd, the engine dropping the required RPMS to turn the solenoid off, and the RPMS returning to the shift point so fast that, although the solenoid technically was turned off, there was insufficient time for the shifter to re-cock itself for the next gear. The solution to this problem is the same as Step One.

**PROBLEM**

THE SOLENOID SHIFTS FROM 1ST DIRECTLY INTO 3RD

**SOLUTION**

First, verify that this is not a shifter problem. (Cable adjustment or improper shifter for the job). If the shifter is correct and the solenoid is shifting from 1st to 3rd, it may be doing it because it is told to or because the ratchet bar to shoulder bolt relationship is wrong. Next, verify the adjustment by confirming the gap between the ratchet bar tooth and shoulder bolt is approximately 3/16 inch. See Above. If the ratchet bar will not drop over the shoulder bolt in each gear, the gap will have to be increased by sliding the solenoid closer to the shifter. If the shifter is going from 1st to 2nd and 2nd to 3rd so fast that you perceive it as 1st to 3rd, this would result from drive train slippage. The slippage allows for the engine RPMS to tell the RPM switch to turn on-off, and on-off too fast. Solutions to this problem are the same as above. See STEP TWO.

FOR ADDITIONAL TECHNICAL SUPPORT OR WARRANTY

CONTACT:

SHIFNOID'S DISTRIBUTOR:

Contender Performance Products, Inc.  
6909 Columbus Rd. Granville, OH 43023  
740-927-0060

**SHIFNOID # SN999 WIRE GUARD**  
FOR SN5070, SN5055B AND SN5055H  
SHIFT ACTIVATORS

USED TO PROTECT THE WIRING FROM DAMAGE CAUSED BY CONTACT  
FROM SEAT BELTS, HELMETS, HANDLING, ETC.  
( INSTALLATION IS OPTIONAL )

TO INSTALL, WHILE HOLDING THE SOLENOID IN  
PLACE, REMOVE THE TWO M5 X 8 BUTTON HEAD  
SCREWS THAT ATTACH THE SOLENOID TO THE  
BRACKET. INSTALL THE WIRE GUARD AS SHOWN  
USING THE TWO WASHERS AND M5 X 10 SCREWS  
SUPPLIED.

