

# Part #537C, 704 1957 Rocker Panel Moulding and Clips

## Instruction Sheet Master

Revised 5/2018

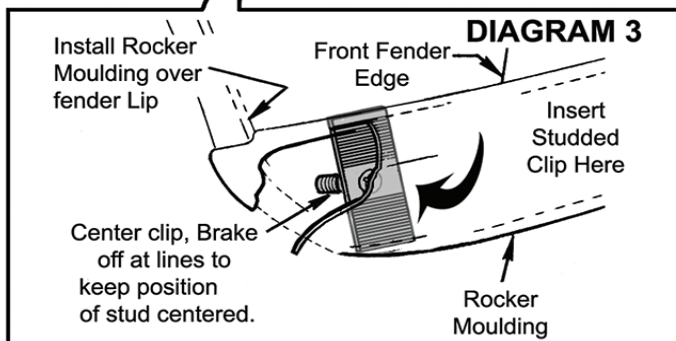
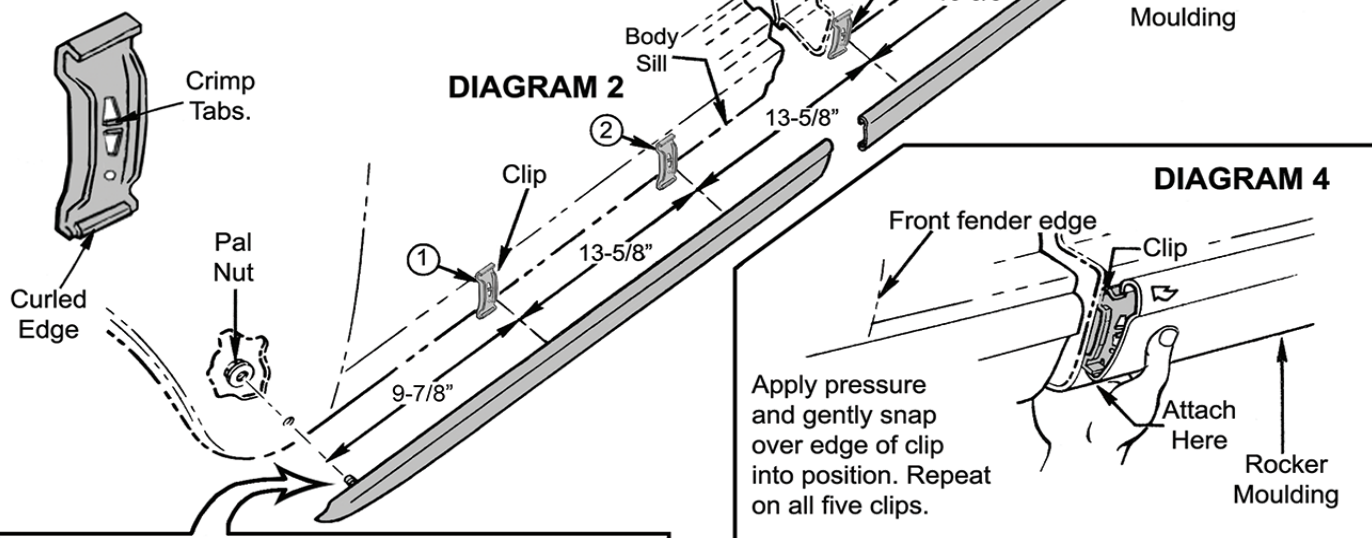
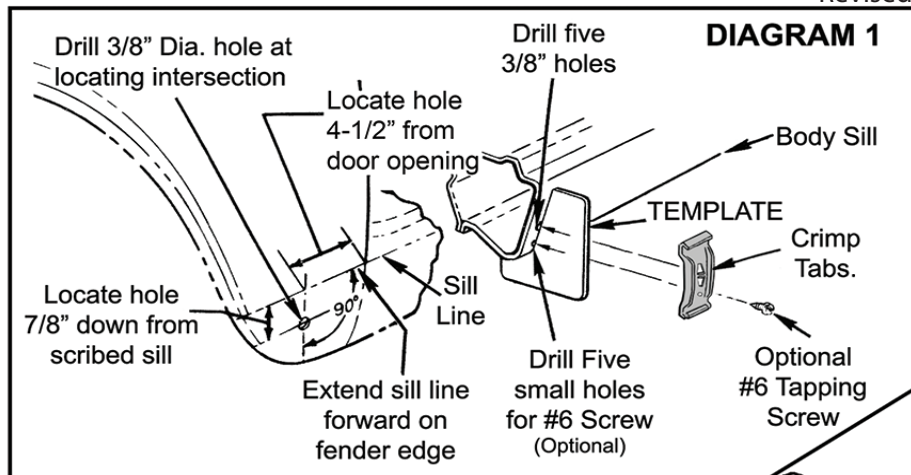

1. Locate and drill 3/8" hole in the fender. See Diagram 1.
2. Mark locations for 3/8" holes in body sill from door opening as shown in Diagram 1.
3. Place the moulding clip with stud inside Rocker Moulding. You will need to brake off the ends to center clip and align with hole. See Diagram 3.
4. After locating the first of the five other holes a template can be made to help mark other holes.

5. Locate the five other holes and drill only 3/8" holes at this time.

6. Place the tabbed clip into second hole with curled ends facing you, see Diagram 2. Insert tabs of the clips inside holes. Using pliers crimp the tabs on face of clip to the car body.

**Optional:** drill the five smaller holes, and install #6 tapping screws (not included).

7. Place the front edge of the moulding with clip slide stud (do not install nut) through drilled hole being sure to locate the moulding over the fender lip as shown in Diagram 3.

8. Hook Rocker Moulding on bottom edge of clips and apply pressure gently at top edge of moulding and snap into place. See Diagram 4.

9. Tighten forward-most retainer clip in place with pal nut provided.

10. Repeat on other side of the car.