

# PART # - 531 Outside Rear View Mirror

## Instruction Sheet Master

Revised 12/2017

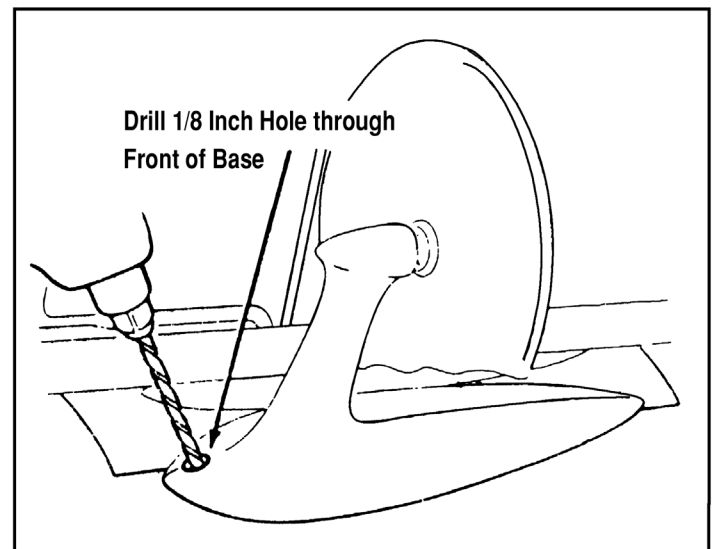
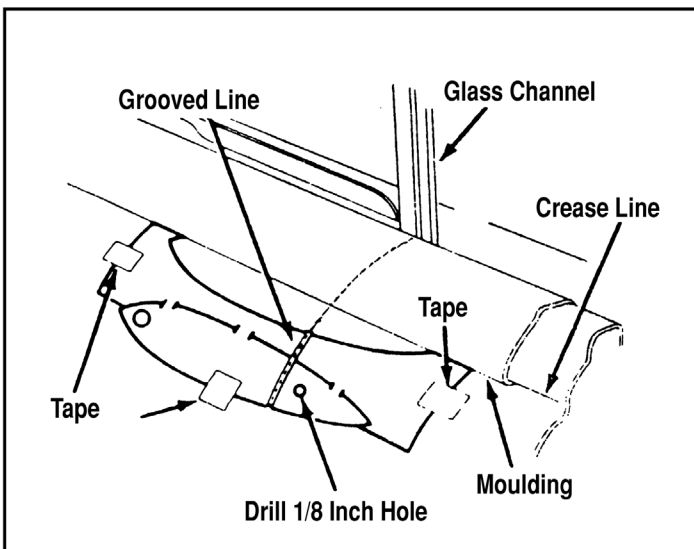
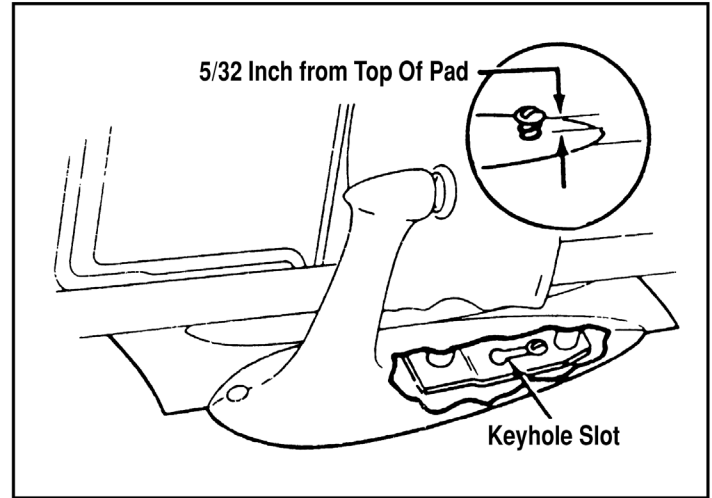
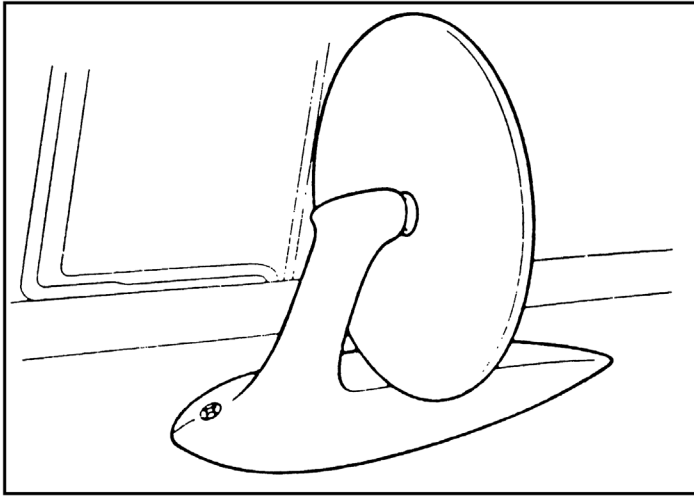

1. Position the bracket pad against the door crease molding, or corresponding crease line, and line up the grooved line on the pad with the rear edge of the ventilator glass as illustrated.
2. Center punch the door panel through the 1/8 inch hole in the pad. Remove the pad and drill a 1/8 inch hole.
3. Tape the pad in place on the door panel with the 1/8 inch holes lined up.
4. Drive the 5/8 inch tapping screw through the drilled hole until the screw head bearing surface measures 5/32 above the surface of the pad.
5. Fit the mirror base over the pad so the raised screw head indexes the round end of the keyhole slot in the retaining bracket.
6. Slide the mirror base forward until tight against the pad and fitting the indicated outline.
7. Hold the front of the mirror base firmly against the pad and, using the hole in the base as a guide, drill a 1/8 inch hole through the door panel.
8. Complete the attachment with the 3/4 inch trim screw provided and remove the excess pad.