

# Installation Instructions

## O.E. Xtreme Brackets Part # 6840436

2015 Chevrolet Silverado / GMC Sierra 2500HD, 3500HD Crew Cab ( Gas & Diesel)

### Parts List

Item	Qty.	Part #	Description	Torque
1	1 Pr	393014AA	Front Cab Bracket	-
2	1 Pr	393014BA	Middle Cab Bracket	-
3	1 Pr	3912036AA	Rear Cab Bracket	-
4	1 Pr	393014DA	Front Auxiliary Bracket	-
5	1 Pr	391014FA	Middle Auxiliary Bracket	-
6	1 Pr	391014EA	Rear auxiliary bracket	-
7	1 Pr	3912033AA	Rear Frame Bracket	-
8	1 Pr	3912035AA	Rear Bracket	-
9	2	396801AA	Clamp Bracket	-
10	6	3713312	5/16" Bolt Plate	-
11	16		5/16" x 1" Hex Bolt	15 Ft. Lbs.
12	22		5/16" Flat Washer	-
13	22		5/16" Lock Washer	-
14	6		5/16" Hex Nut	15 Ft. Lbs.
15	10		3/8"x1" Carriage Bolt	30 Ft. Lbs.
16	10		3/8" Flat Washer	-
17	10		3/8" Lock Washer	-
18	10		3/8" Hex Nut	30 Ft. Lbs.
19	2		1/2" Flat Washer	-

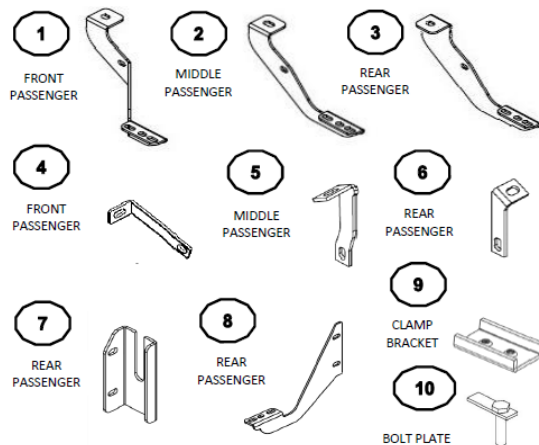

#### Tool Required:

1/2", 9/16", 21mm & 22mm Socket  
 1/2" & 9/16" Wrench  
 Ratchet & Ratchet Extension

**Approximate Installation Time: 90 min**

**Read the installation instructions completely and verify that all of the parts listed are accounted for. If you have defective, missing or damaged parts or need assistance, please contact *Go Rhino Products* for fast, friendly customer service at: 1-888-427-4466 or email: [warranty@gorhino.com](mailto:warranty@gorhino.com)**

**WARNING!** GM uses thread-locking compound on all factory body mount bolts. Removal using an air assisted impact or ratchet will damage the body mount bolt threads and the internal nut assembly. We only recommend using hand tools to slowly remove and reinstall body mount bolts on all GM vehicles.

**IMPORTANT!** If during the body mount bolt removal process, it becomes increasingly difficult to unscrew the bolt with hand tools, tighten the bolt several rotations to clear the thread-locking compound from the threads, then reverse the direction and continue to unscrew the bolt until it is out. Repeat this process as necessary on all of the body mount bolts. Use of an appropriate anti-seize compound is highly recommended for re-installation. Tighten the body mount bolts to factory torque specifications.

## Installation

**Step-1** Begin the installation by removing the passenger side front body mount bolt, **(Photo 1)**.

Keep all existing washers and bushing in place, and attach the passenger side front bracket to the vehicle using the factory body mount bolt. Leave the bolt loose for final adjustment, **(Photo 2 & Illustration 1)**.

**Step-2** Locate the obround hole in the underside of the body and install one of the 5/16" bolt plates. **Photo #1**

Attach the passenger side front auxiliary bracket to the body using the bolt plate, (1) 5/16" flat washer, (1) 5/16" lock washer and (1) 5/16" hex nut. Attach the opposite end of the auxiliary bracket to the side of the front bracket using (1) 3/8" x 1" carriage bolt, (1) 3/8" flat washer, (1) 3/8" lock washer and (1) 3/8" hex nut. Leave the nuts and bolts loose for final adjustment, **Photo 2 & Illustration 1)**.

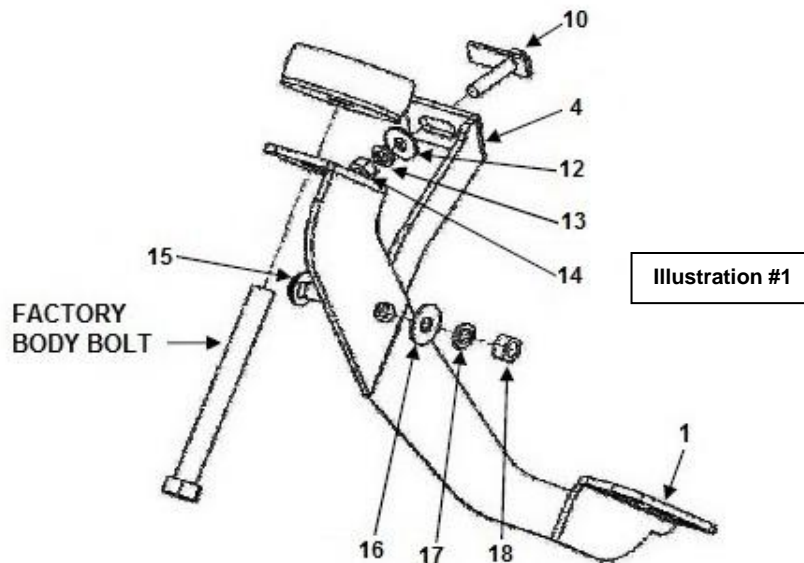
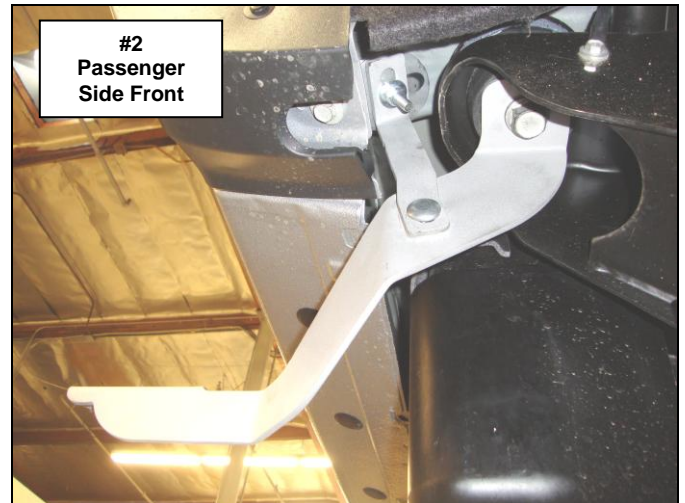
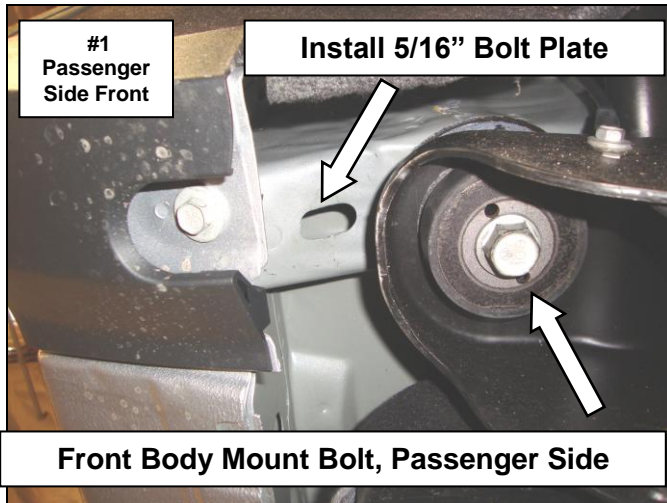

**Step-3** Remove the passenger side middle body mount bolt, **(Photo 3)**.

Keep all existing washers and bushing in place, and attach the passenger side middle bracket to the vehicle using the factory body mount bolt. Leave the bolt loose for final adjustment, **(Photo 4 & Illustration 2)**.

**Step-4** Locate the obround hole in the underside of the body and install one of the 5/16" bolt plates, **(Photo 3)**.

Attach the passenger side middle auxiliary bracket to the body using the bolt plate, (1) 5/16" flat washer, (1) 5/16" lock washer and (1) 5/16" hex nut. Attach the opposite end of the auxiliary bracket to the side of the middle bracket using (1) 3/8" x 1" carriage bolt, (1) 3/8" flat washer, (1) 3/8" lock washer and (1) 3/8" hex nut. Leave the nuts and bolts loose for final adjustment, **(Photo 4 & Illustration 2)**.

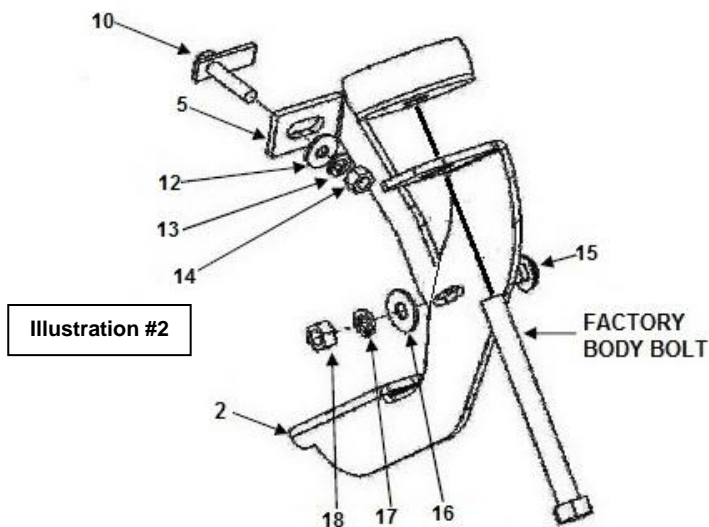
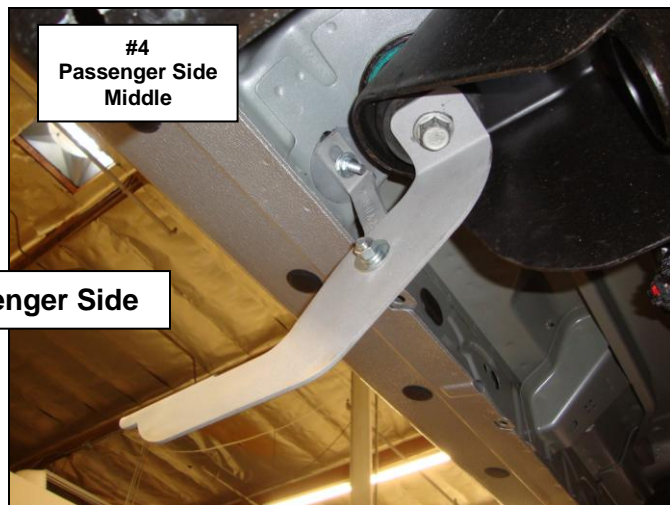
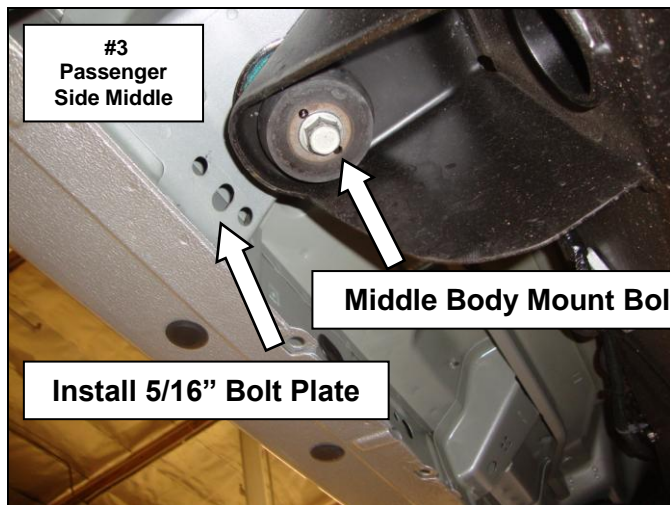

**Step-5** Remove the passenger side rear body mount bolt, **(Photo 5)**.

Keep all existing washers and bushing in place, and attach the passenger side rear bracket to the vehicle using the factory body mount bolt and supplied 1/2" flat washer. Leave the bolt loose for final adjustment, **(Illustration 3)**.

**Step-6** Locate and remove the plastic plug in the body rocker panel to expose the round hole, and install one of the 5/16" bolt plates, **(Photo 5)**.

Attach the passenger side rear auxiliary bracket to the body rocker panel using the bolt plate, (1) 5/16" flat washer, (1) 5/16" lock washer and (1) 5/16" hex nut. Attach the opposite end of the auxiliary bracket to the side of the rear bracket using (1) 3/8" x 1" carriage bolt, (1) 3/8" flat washer, (1) 3/8" lock washer and (1) 3/8" hex nut. Leave the nuts and bolts loose for final adjustment, **(Photo 6 & Illustration 3)**.

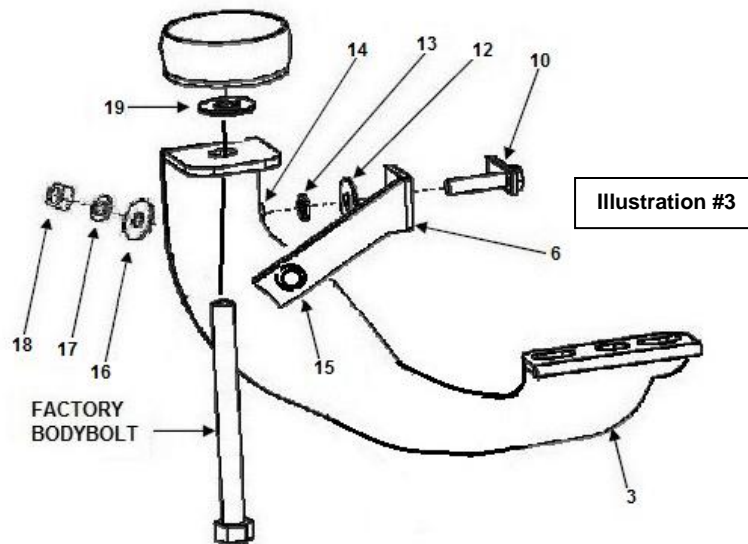
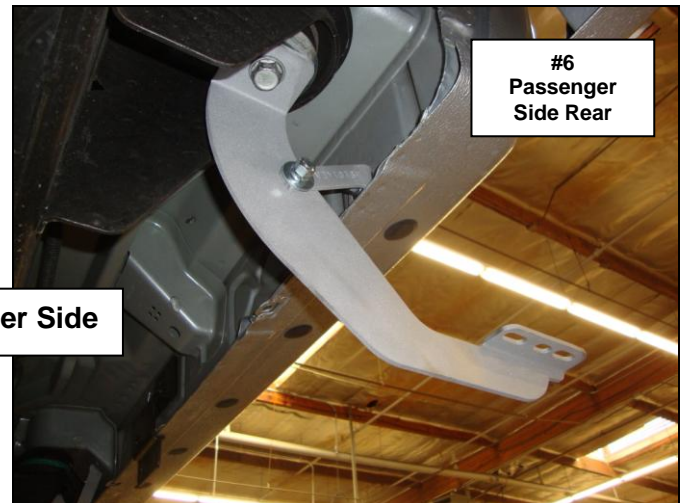
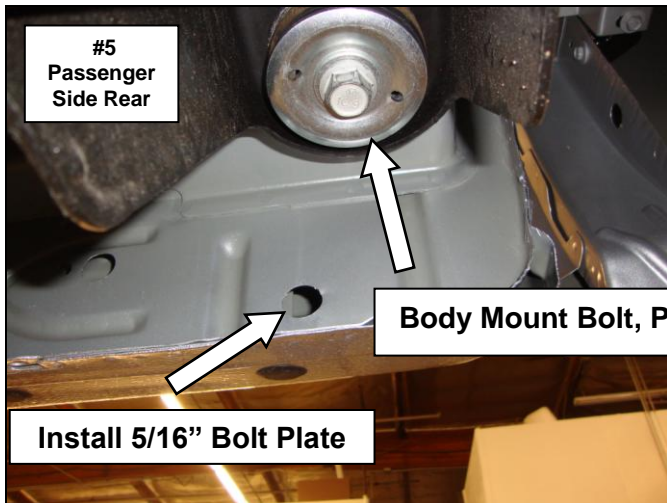

**Step-7** Assemble the driver side frame and rear bracket using (2) 3/8" x 1" carriage bolts, (2) 3/8" flat washers, (2) 3/8" lock washers and (2) 3/8" hex nuts. Leave the nuts and bolts loose for final adjustment, (**Illustration 4**).

**Step-8** Loosen the spring hanger bolt just enough so that the frame and rear bracket assembly can be slide up and positioned behind the flange of the spring hanger bolt, (**Photo 7 & 8**).

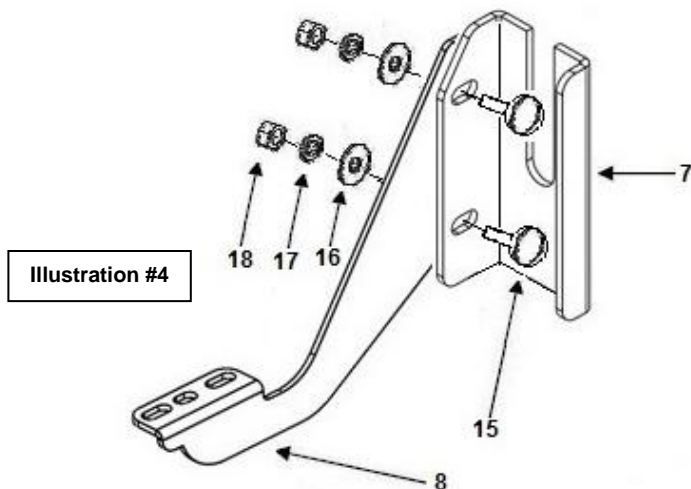
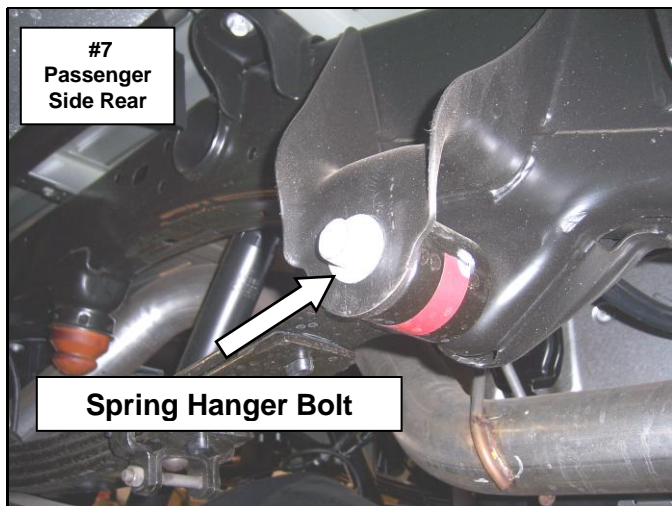

**Step-9** Attach the side step to each bracket using (1) U-bracket (2) 5/16" hex bolts (2) 5/16" lock washers and (2) 5/16" flat washers then align the side step with the vehicle and tighten all side step and bracket nuts and bolts, (**Photo 7 & 8**).

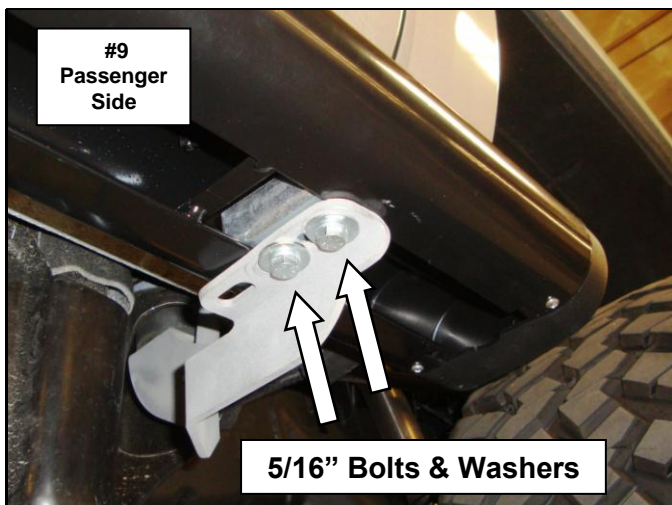

**Step-10** Repeat the installation steps to install the driver side brackets and side step. Remember to check and retighten all nuts and bolts periodically.