

Installation Instructions

BR20 Rear Bumper Replacement Part Number 28295T

2015-2016 Ford F-150 2/4WD

Do not attempt to install this product on any vehicle other than the one listed above!

Parts List

Item	Qty.	Part #	Description	Item	Qty.	Part #	Description	Torque
1	1		Bumper Replacement Shell	10	5		Plastic Hole Plug	
2	1		Driver Side Frame Bracket	11	10		10-32 x 3/4" Button Head Bolt	65 In. Lbs.
3	1		Passenger Side Frame Bracket	12	10		10-32 Nylon-Insert Lock Nut	
4	2		Flush Mount Light Pod Plate	13	4		1/2" x 1 1/2" Hex Bolt	65 Ft. Lbs.
5	1		Sensor Bezel Plate (driver inner)	14	6		1/2" x 2" Hex Bolt	65 Ft. Lbs.
6	1		Sensor Bezel Plate (driver outer)	15	20		1/2" Flat Washer	
7	1		Sensor Bezel Plate (passenger inner)	16	10		1/2" Lock Washer	
8	1		Sensor Bezel Plate (passenger outer)	17	10		1/2" Hex Nut	
9	2		LED License Plate Light					

ILLUSTRATION #1

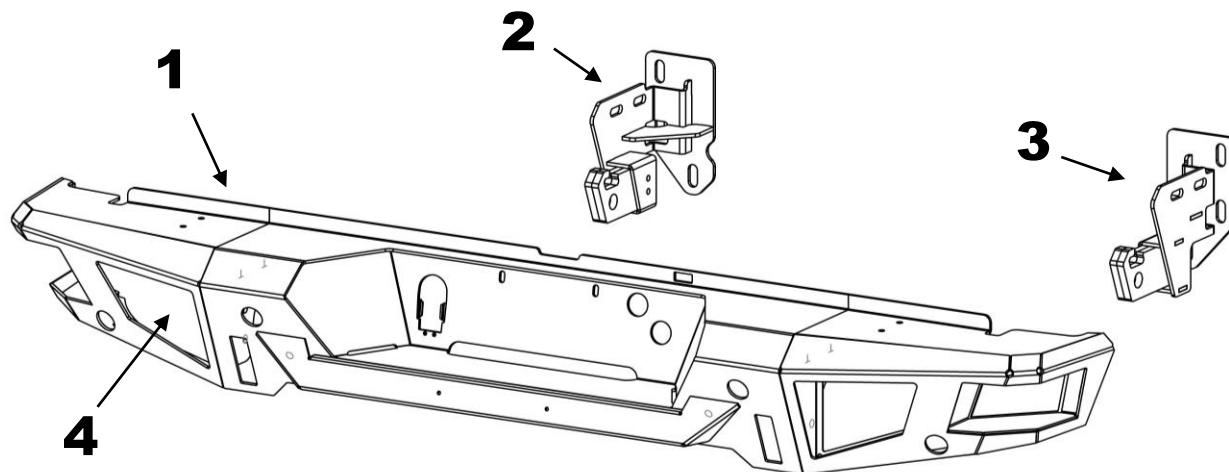

Tool Required:

10mm, 13mm, 21mm, 3/8" & 3/4" Sockets
 10mm, 13mm, 21mm, 3/8" & 3/4" Wrenches
 Slotted Blade Screw Driver
 1/8" Hex Key
 Ratchet, Ratchet Extensions & Swivel Joint Adapter
 12V Circuit Tester

Approximate installation time: 90 min

Read the assembly and installation instructions completely and verify that all of the parts listed are accounted for. If you have defective, missing or damaged parts or need assistance, please contact Go Rhino Products for fast, friendly customer service at: (888) 427-4466 or email: sales@gorhino.com

Factory Bumper Removal

Step-1 Disconnect the vehicle battery or batteries.

Step-2 Disconnect the factory bumper wiring harnesses from the vehicle wiring harness, (Photo 1).

Step-3 Remove (2) tree clips and bolt securing the wiring harness ground wire to the frame, (Photo 2).

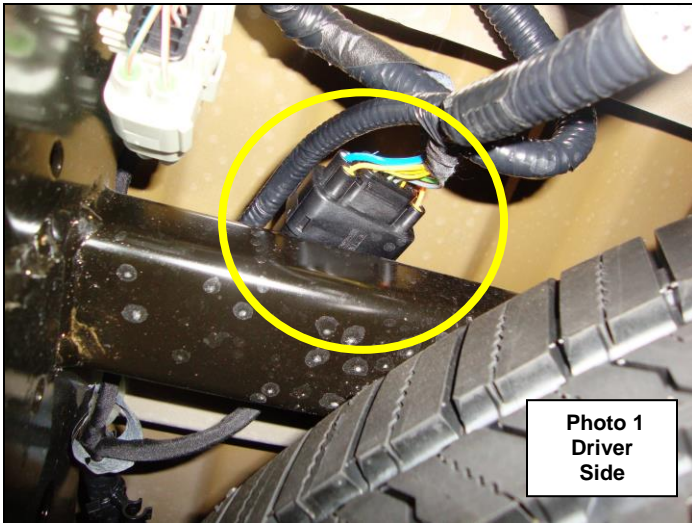

Photo 1
Driver
Side

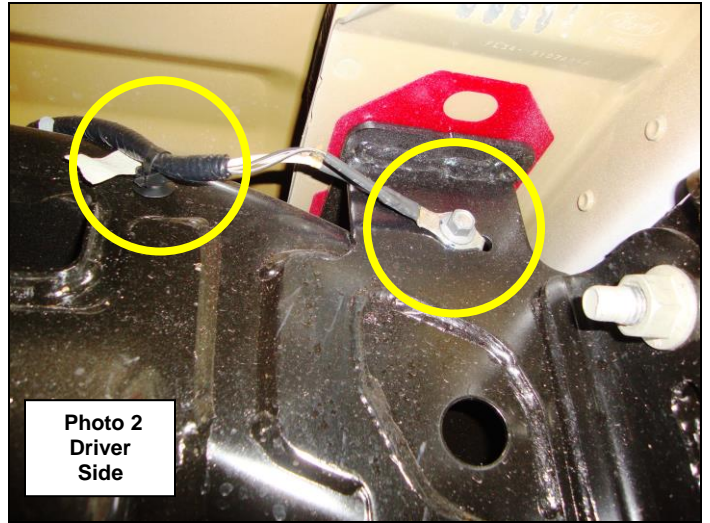

Photo 2
Driver
Side

Step-4 With assistance support the rear bumper and remove the (3) nuts on each side of the vehicle securing the factory bumper and receiver hitch to the frame. Remove the bumper from the vehicle, (Photo 3).

Step-5 Disconnect the license plate lights, trailer plug (Photo 4) and If equipped disconnect the backup sensors from the factory bumper wiring harness. Remove the wiring harness from the factory bumper.

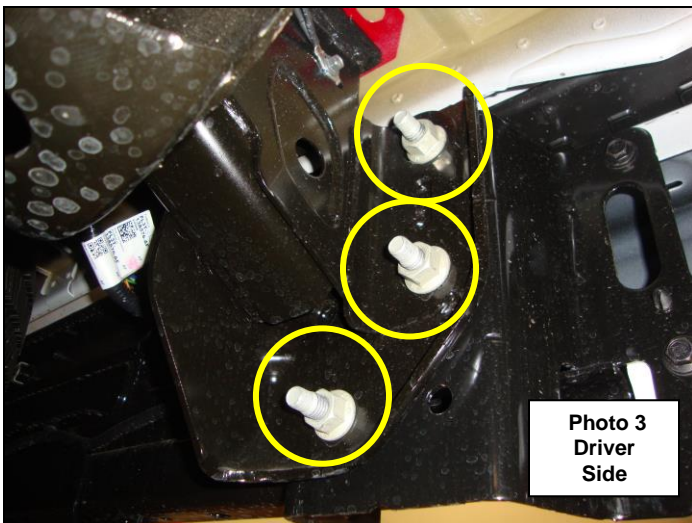

Photo 3
Driver
Side

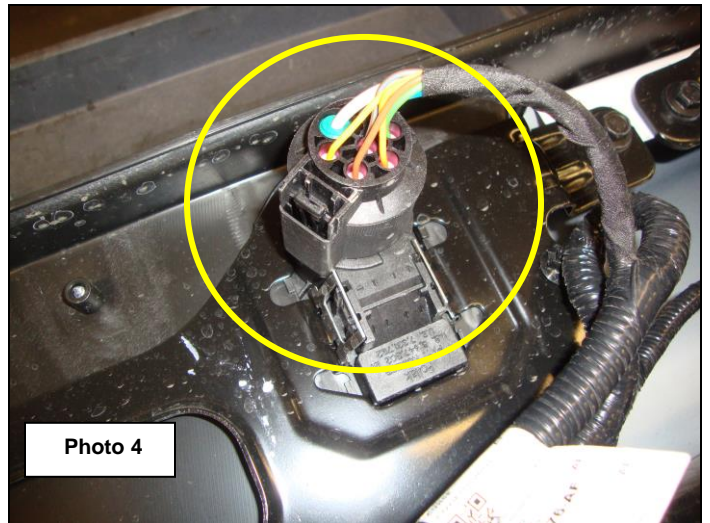
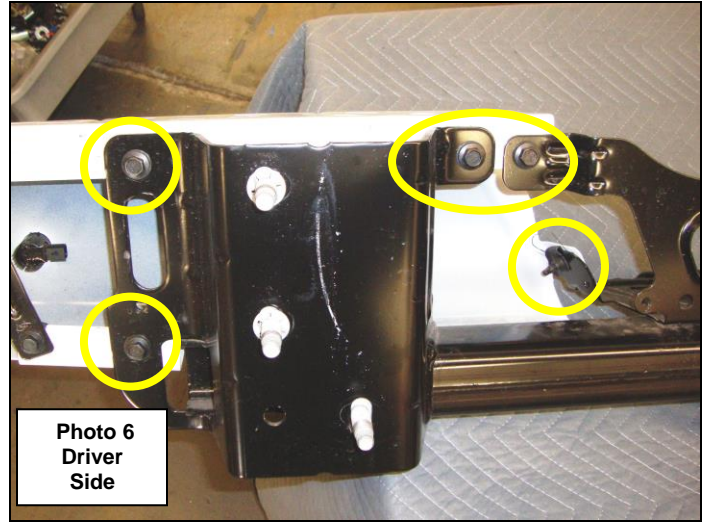
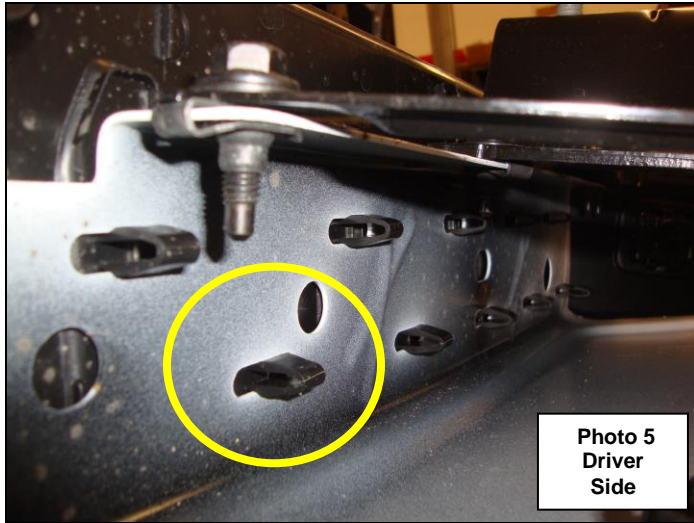

Photo 4

Step-6 The factory bumper consists of (3) components. Begin by removing the plastic top pad and center component from the bumper end caps by pulling up from the outside edge. To ease removal, the plastic clips can be popped loose from the underside of the bumper end caps, (Photo 5).

Step-7 Remove the bumper end caps by removing the (5) bolts securing each end cap to the receiver hitch, (Photo 5).

The factory bumper consists of (3) components. Begin by removing the plastic top pad and center component from the bumper ends by pulling up from the outside edge. To ease removal, the plastic clips can be popped loose from the underside of the bumper ends, (Photo 5).



Step-8 Remove the retaining clips and stud plates from the factory receiver hitch, (Photo 7).

Step-9 Cut and remove the bumper attachment flanges for the bumper end caps (driver and passenger side), and the outlined area for the trailer plug mount from the factory receiver hitch, (Photo 8).

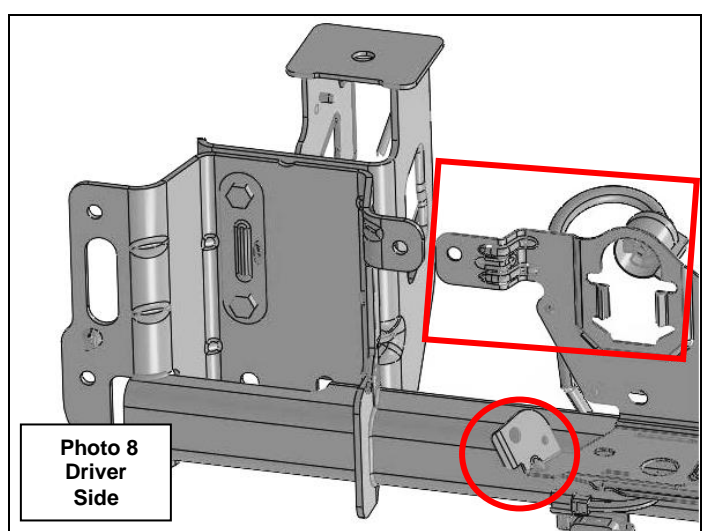
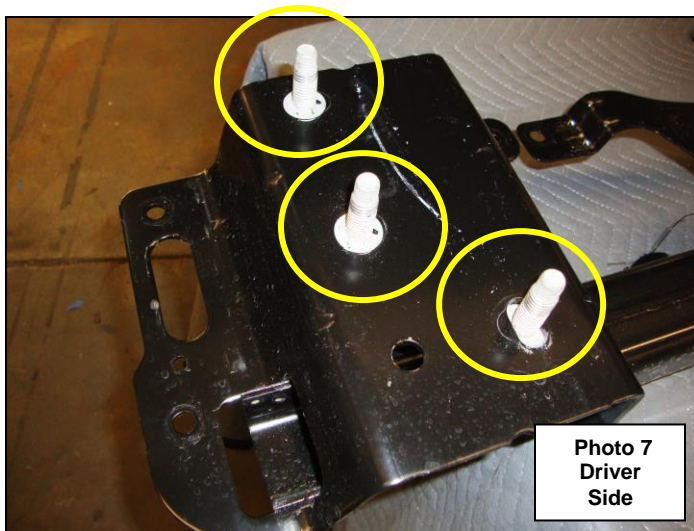

BR20 Bumper Replacement Installation

Note: if your vehicle is not equipped with rear **Park Assist** install the supplied round plugs in the holes in the replacement bumper and proceed to Step 8.

Note: If you are replacing a bumper with rear **Park Assist**, the sensor detection zone will be altered with use of this bumper replacement.

Step-1 If the vehicle is equipped with rear **Park Assist**, remove each sensor from the bezel by gently spreading the bezel tabs and pulling out on the back of the sensors. Note: Do not push on the front of the sensor as this may damage the sensor.

Step 2 Remove the sensor bezels from the factory bumper by depressing the (4) tabs around the base and pushing the bezel out through the front of the bumper. Note: The sensors and bezels have to be positioned in the replacement bumper in the same location (inner and outer), (driver and passenger) as removed from the factory bumper.

Step-4 Install the sensor bezels and sensors in the supplied (inner & outer) bezel plates, (Illustration 1). From the side with applied tape, line up the protrusions on the bezel with the profile in the bezel plate; push the bezel through the profile in the plate until the tabs around the base lock in position, then install the sensor in the bezel. Note: The U notches in the sensor plates designate the top, and the V notch on the side of the inner bezel plate position toward the center of the vehicle.

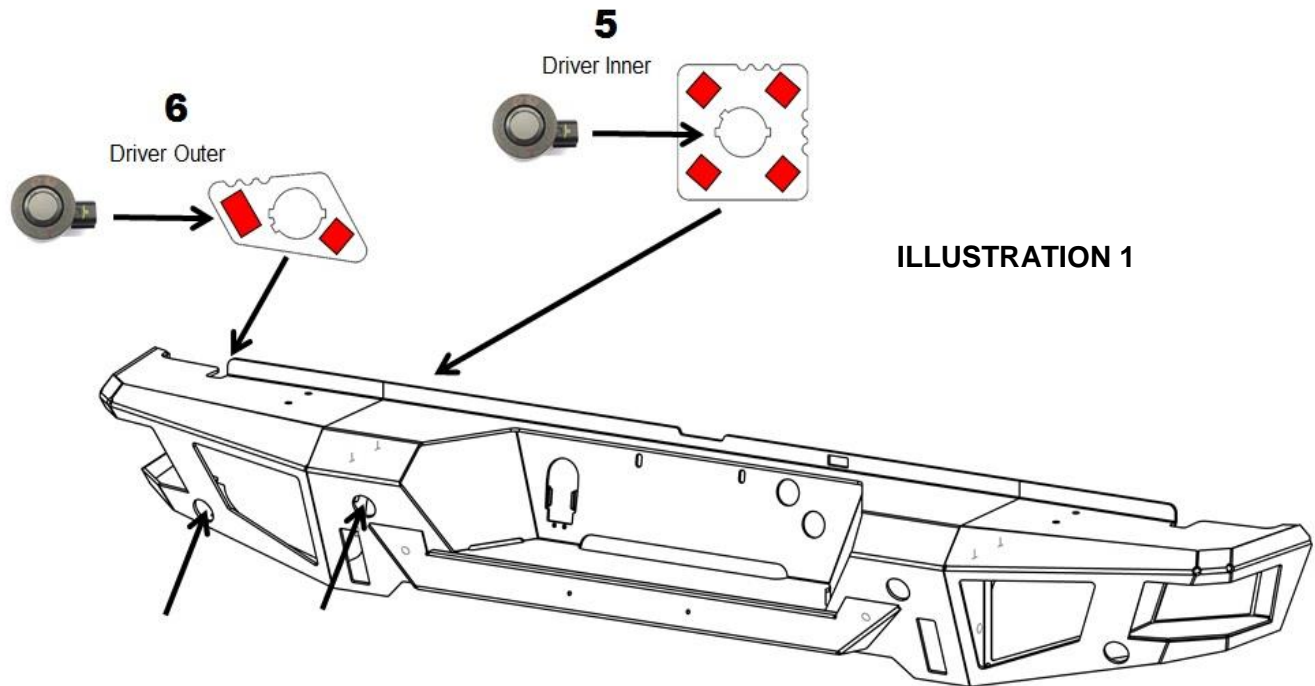

ILLUSTRATION 1

Step-5 Prepare the inside surface of the bumper shell where the bezel plates will be mounted with Isopropyl alcohol. A clean, dry surface is required in order for tape to stick properly.

Step-6 Peel the backing off from the double sided tape to uncover the adhesive. From inside the bumper shell position each bezel, sensor and bezel plate assembly, making sure the sensor bezel is centered in the hole provided in the bumper shell.

Step-7 Stick the assembly in place and apply firm pressure for about 30 seconds. The tape needs to bond with the mounting surface, and it needs pressure to do this. The bezel mounting plate will seem like it is stuck on, but continue pressing for at least 30 seconds. Note: At room temperature approximately 50% of ultimate bond strength will be achieved after 20 minutes, 90% after 24 hours and 100% after 72 hours.

Step-8 With assistance attach the receiver hitch and each frame bracket to the frame using (3) $\frac{1}{2}$ " x 2" hex bolts, (6) $\frac{1}{2}$ " flat washers, (3) $\frac{1}{2}$ " lock washers and (3) $\frac{1}{2}$ " hex nuts. nuts, (Photo 1 & 2). Leave the nuts and bolts loose for final adjustment.

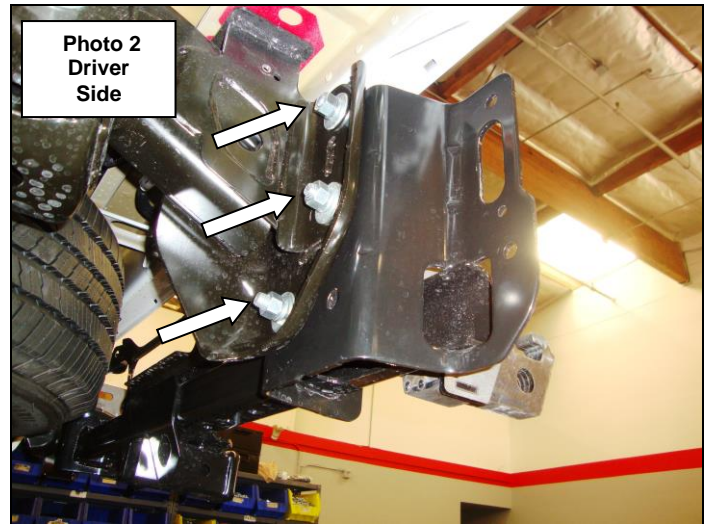
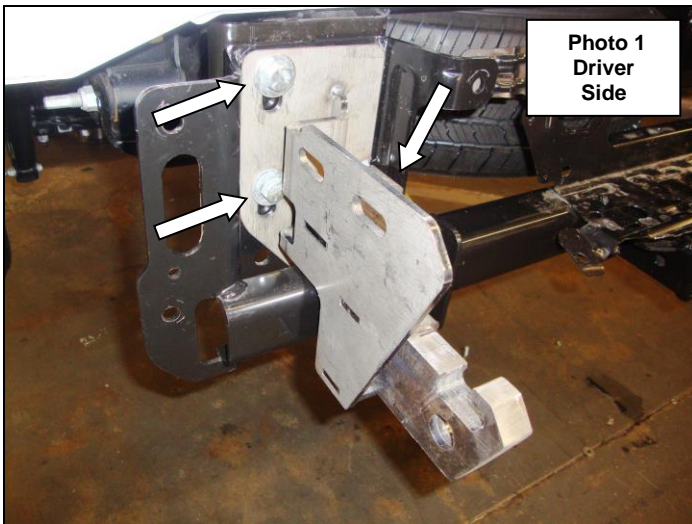

Step-9 With assistance attach the bumper shell brackets to each frame bracket using (2) $\frac{1}{2}$ " x 1 $\frac{1}{2}$ " hex bolts, (4) $\frac{1}{2}$ " flat washers, (2) $\frac{1}{2}$ " lock washers and (2) $\frac{1}{2}$ " Hex nuts, (Photo 3 & 4).

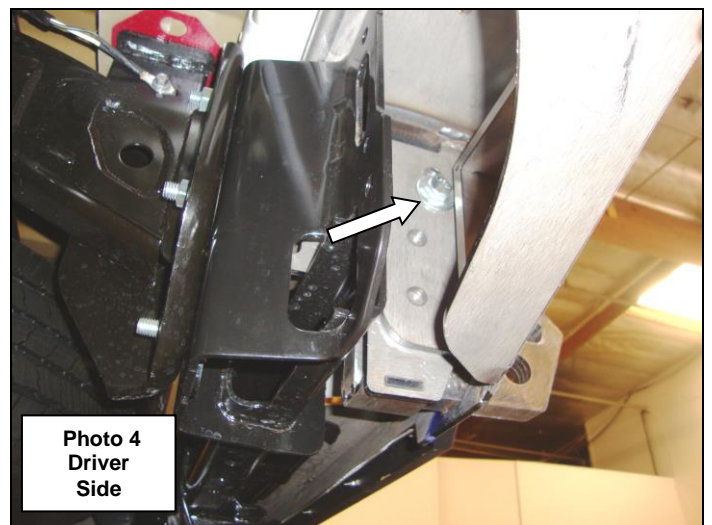
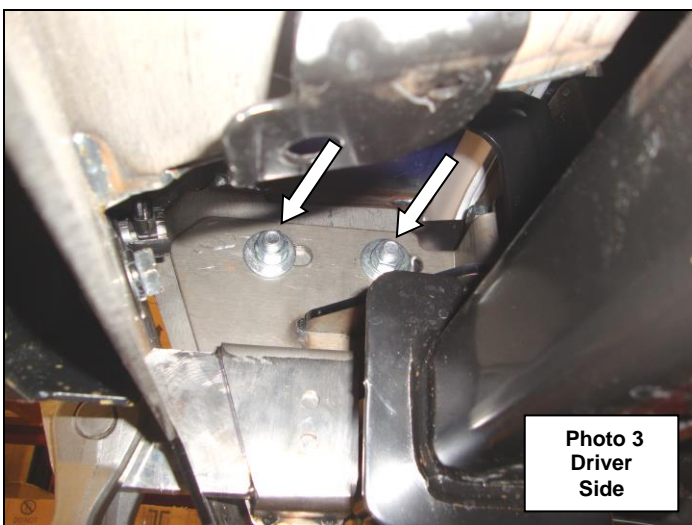

Step-10 Align the bumper shell with the vehicle, verify that the tailgate clears when lowered, and tighten all nuts and bolts, (Photo 5).

Step-11 Remove the trailer plug from the factory bumper and install it in the replacement bumper shell, and reconnect the wiring harness, (Photo 6).

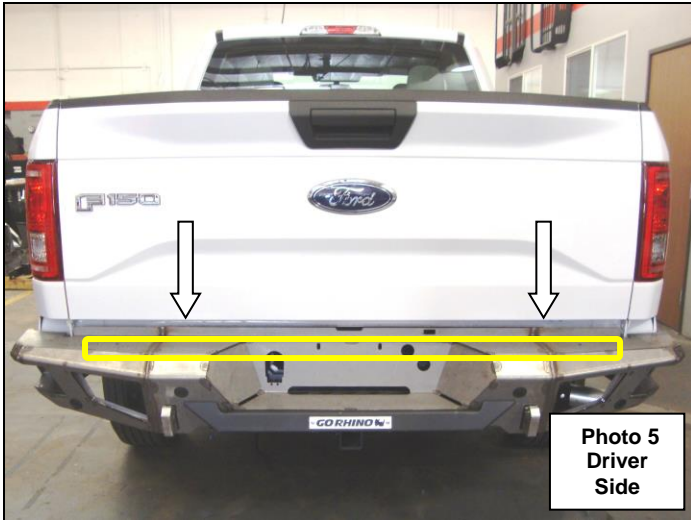

Step-12 Reconnect the factory bumper wiring harness to the sensors and to the vehicle wiring harness.

Step-13 Install the license plate using the supplied LED lights and fasteners to the bumper shell. Use a circuit tester to find the hot and ground from the factory license plate light wiring, and then splice the wires from the supplied lights.

Step-14 Install the supplied round plugs to fill the unused winch access tube holes in the bumper shell.

Step-15 Install the supplied flush mount light pods plates or optional light mounts to the bumper shell using (4) 10-32 x 3/4" button head bolts and (4) 10-32 lock nuts.

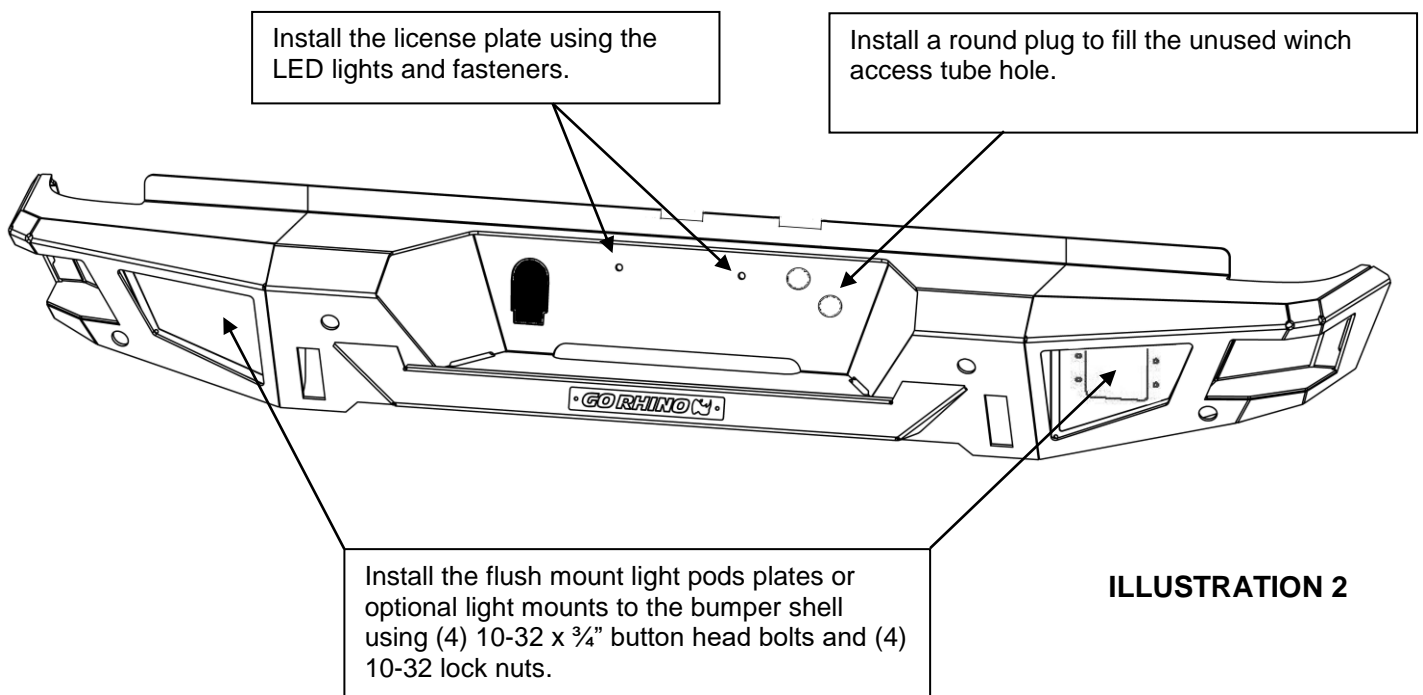

Step-16 Remember to check and retighten all factory and supplied nuts and bolts periodically.