

INSTALLATION MANUAL

70110

Level of Difficulty

Moderate

Installed Attachment Tabs

Height	17"
Width	24"

Parts List

Item	Qty	Description
1	1	Tow bar base plate
2	2	Spacer plate, 1" x 5/8"
3	2	Tow bar mounting tab
4	2	Safety cable, 7,500 lbs.
5	4	Square hole spacer, 1/4" x 1" x 2-1/2"
6	4	Carriage bolt, 1/2"-13 x 2", grade 8
7	4	Flange nut, 1/2"-13, grade 8
8	2	Square hole spacer, 3/8" x 1-1/4" x 2-1/2"
9	2	Carriage bolt, 5/8"-11 x 2", grade 8
10	2	Flange nut, 5/8"-11, grade 8
11	2	Quick link, 1/4"
12	2	Socket plug

Tools Required

Torque wrench	Drill
Socket, 3/4"	Drill bit, 17/32"
Socket, 5/16"	Tape measure
Socket, 15mm	Large vise grip
Socket, 18mm	Reciprocating saw
Fishwire, 1/2" (includes four)	--

⚠ WARNING

Never exceed the vehicle manufacturer's recommended gross vehicle weight rating (GVWR).

Product Photo



Not pictured: Safety cables, quick links and socket plugs

⚠ CAUTION

Take care when cutting any plastic or metal as injury may occur if done improperly.

NOTICE

Before you begin installation, read all instructions thoroughly.

Proper tools will improve the quality of installation and reduce the time required.

This installation requires the front underbody panel and metal bumper to be removed and reinstalled. Some drilling and trimming are required.

To help prevent damage to the product or vehicle, refer to the specified torque specifications when securing hardware during the installation process.

If equipped, we recommend removing the base plate attachment tabs when not in use.

Torque Specifications

Metric	Bolt Size	CL8.8	CL10.9	SAE	Bolt Size	Grade 5	Grade 8
	M6 bolt	6.6 ft-lbs.	9.4 ft-lbs.		1/4" bolt	86 in-lbs.	122 in-lbs.
M8 bolt	16.0 ft-lbs.	22.9 ft-lbs.	5/16" bolt	178 in-lbs.	251 in-lbs.		
M10 bolt	31.6 ft-lbs.	45.2 ft-lbs.	3/8" bolt	26 ft-lbs.	37 ft-lbs.		
M12 bolt	55.1 ft-lbs.	78.9 ft-lbs.	7/16" bolt	42 ft-lbs.	59 ft-lbs.		
M14 bolt	88.1 ft-lbs.	126.1 ft-lbs.	1/2" bolt	75 ft-lbs.	110 ft-lbs.		
M16 bolt	136.7 ft-lbs.	195.6 ft-lbs.	5/8" bolt	128 ft-lbs.	180 ft-lbs.		
M18 bolt	195.4 ft-lbs.	270.3 ft-lbs.	3/4" bolt	227 ft-lbs.	320 ft-lbs.		

Use above torque setting unless otherwise noted

ASSEMBLY

Parts List

Item	Qty	Description
1	1	Tow bar base plate
2	2	Spacer plate, 1" x 5/8"
3	2	Tow bar mounting tab
4	2	Safety cable, 7,500 lbs.
5	4	Square hole spacer, 1/4" x 1" x 2-1/2"
6	4	Carriage bolt, 1/2"-13 x 2", grade 8
7	4	Flange nut, 1/2"-13, grade 8
8	2	Square hole spacer, 3/8" x 1-1/4" x 2-1/2"
9	2	Carriage bolt, 5/8"-11 x 2", grade 8
10	2	Flange nut, 5/8"-11, grade 8
11	2	Quick link, 1/4"
12	2	Socket plug

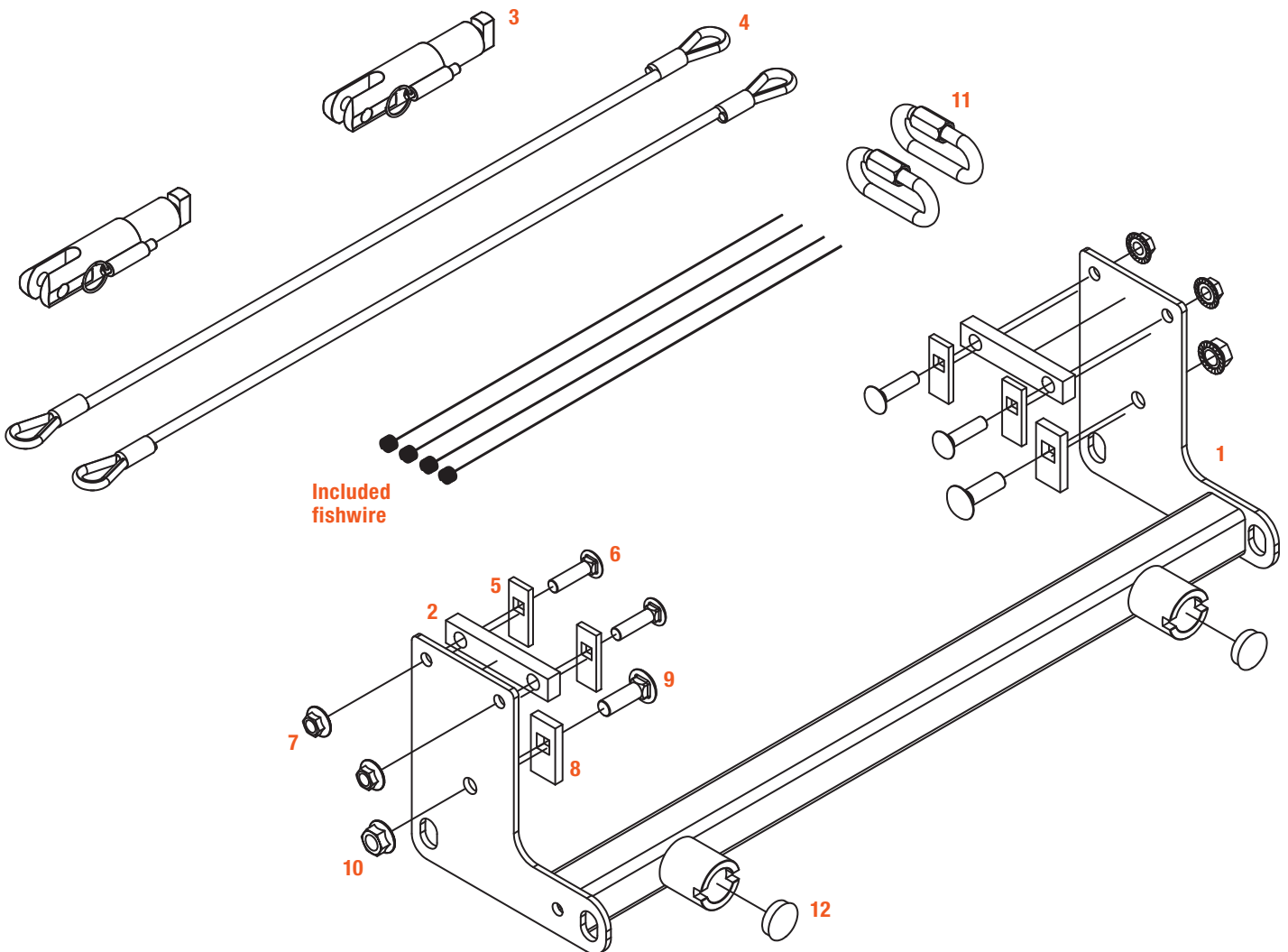

BUMPER REMOVAL

Step 1

Use a 15mm socket to remove the seven bolts from the bottom of the underbody panel – two on either side and three near the front.

Remove the panel and set it aside.

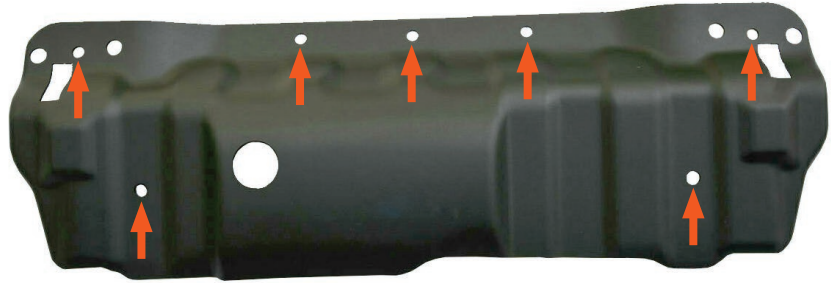

Step 2

Use an 18mm socket to remove the two bolts on the outside of the vehicle's frame. Remove four bolts total – two on each side of the vehicle.

Then, remove the four bolts on the inside of the vehicle's frame – two on either side.



Step 3

Carefully remove the factory bumper, disconnecting the fog light wiring harnesses before complete removal.

Set the bumper aside to be reinstalled later.



TOW BAR BASE PLATE INSTALLATION

Step 4

Position the tow bar base plate (#1) on the vehicle frame and fishwire a 5/8"-11 x 2" carriage bolt (#9) and 3/8" square hole spacer (#8) into the frame rails on each side of the vehicle. Level the tow bar base plate and secure with a 5/8" flange nut (#10) and torque to 212 lb-ft.



Step 5

Using a 17/32" bit, drill the remaining mounting holes in the vehicle frame. Use the side plates as a template.

Then, install a spacer plate (#2) between the vehicle frame and side plate. Fishwire the 1/2"-13 x 2" carriage bolts (#6) and 1/4" square hole spacers (#5) through the end of the frame into position and fasten with 1/2" flange nuts (#7).

Repeat on the other side of the vehicle and torque all 1/2" fasteners to 110 lb-ft.

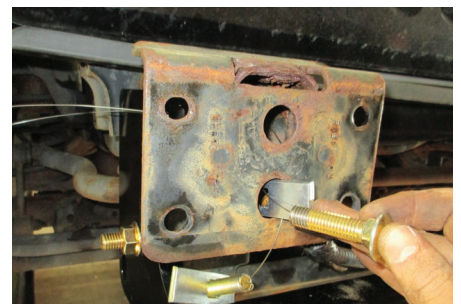
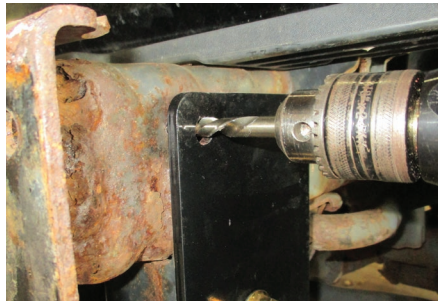

Step 6

Trim the underbody panel previously removed, cutting off a tapered portion 2-1/2" (w) x 7-3/4" (h) on both sides of the vehicle. This will provide clearance for the side plates.



Step 7 - For ARB Stubby Bumpers ONLY

Cut both sides of the bumper, on the underside, to provide clearance for the side plates.

Follow the template as shown.

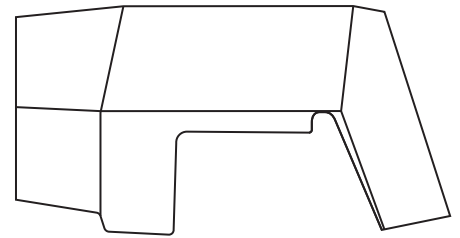
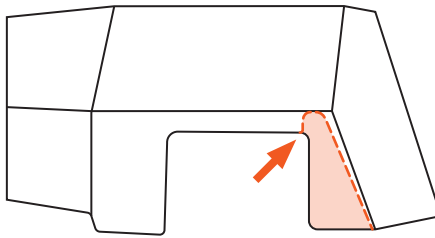

Step 8

Install the permanent safety cables (#4) and quick links (#11), looping them around the vehicle frame and linking them to the tow bar base plate (#1). There must be one cable on each side of the vehicle.

Make sure the cables do not pinch or interfere with any hoses, wiring or other components.

See 'Installing the Permanent Base Plate Safety Cables' for additional information.



Step 9

Reinstall the factory bumper.

When ready to tow, install the tow bar mounting tabs (#3). When not towing, insert the socket plugs (#12) into the ends of the tow bar base plates (#1).



Final Installed Image



SAFETY CABLE INSTALLATION

Installing the Permanent Base Plate Safety Cables

When dinghy towing a vehicle with a tow bar, base plate safety cables should be used at all times. In the event of a disconnect, the safety cables are designed to help prevent complete vehicle separation. When installing the safety cables, use the illustrations below as a guide.

Installation guidelines

1. The cables must be connected to the base plate and the vehicle frame.
2. Two cables must be installed.
3. Each cable must meet or exceed the gross weight of the towed vehicle.
4. Make sure cables do not pinch or interfere with hoses, wiring or other components.

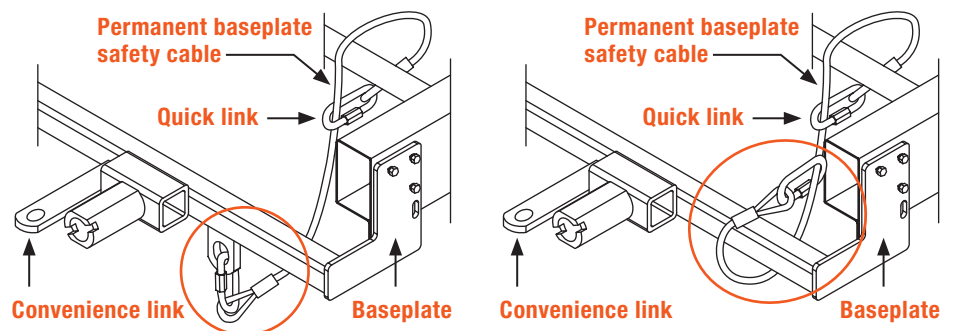

Note: Base plate safety cables are not a replacement for safety chains connecting the tow vehicle to the towed vehicle.

ADDITIONAL INFORMATION

Towing Tips

Check your equipment

Periodically check the condition of all towing equipment. Ensure all fasteners are tight and that all structural components are sound. Do not tow with worn or damaged parts.

Towing vehicle and trailer manufacturer's recommendations

Review the owner's manual for your towing vehicle and trailer for specific recommendations, capacities and requirements.

Product Registration and Warranty

CURT Group stands behind our products with industry-leading warranties.

Provide feedback and help us to improve our products by registering your purchase at: warranty.curtgroup.com/surveys