

13265

03-06 DODGE SPRINTER / MERCEDES BENZ / FREIGHTLINER
ALL DUAL WHEEL MODELS

11/26/2012

GROSS LOAD CAPACITY WHEN USED AS A WEIGHT CARRYING HITCH: 6000 LBS. TRAILER WEIGHT & 600 LBS. TONGUE WEIGHT.
GROSS LOAD CAPACITY WHEN USED AS A WEIGHT DISTRIBUTION HITCH: 10000 LBS. TRAILER WEIGHT & 1000 LBS. TONGUE WEIGHT

DO NOT EXCEED VEHICLE MANUFACTURER'S RECOMMENDED TOWING CAPACITY.

HAVING INSTALLATION QUESTIONS? CALL TECHNICAL SUPPORT AT 1-800-798-0813

Parts List			
ITEM	QTY	PART NUMBER	DESCRIPTION
1	1	1/2"	FISHWIRE TOOL
2	2	CM-SP10	.250 x 1.00 x 2.50" SQUARE HOLE SPACER
3	8	HFN 1213	HEX FLANGE NUT
4	6	1/2 - 13 x 4	HEX BOLT
5	6	1/2"	WASHER
6	2	CM-SP143	PLATE .250" A-36 H.R.
7	2	1/2-13 x 1 1/2	CARRIAGE BOLT

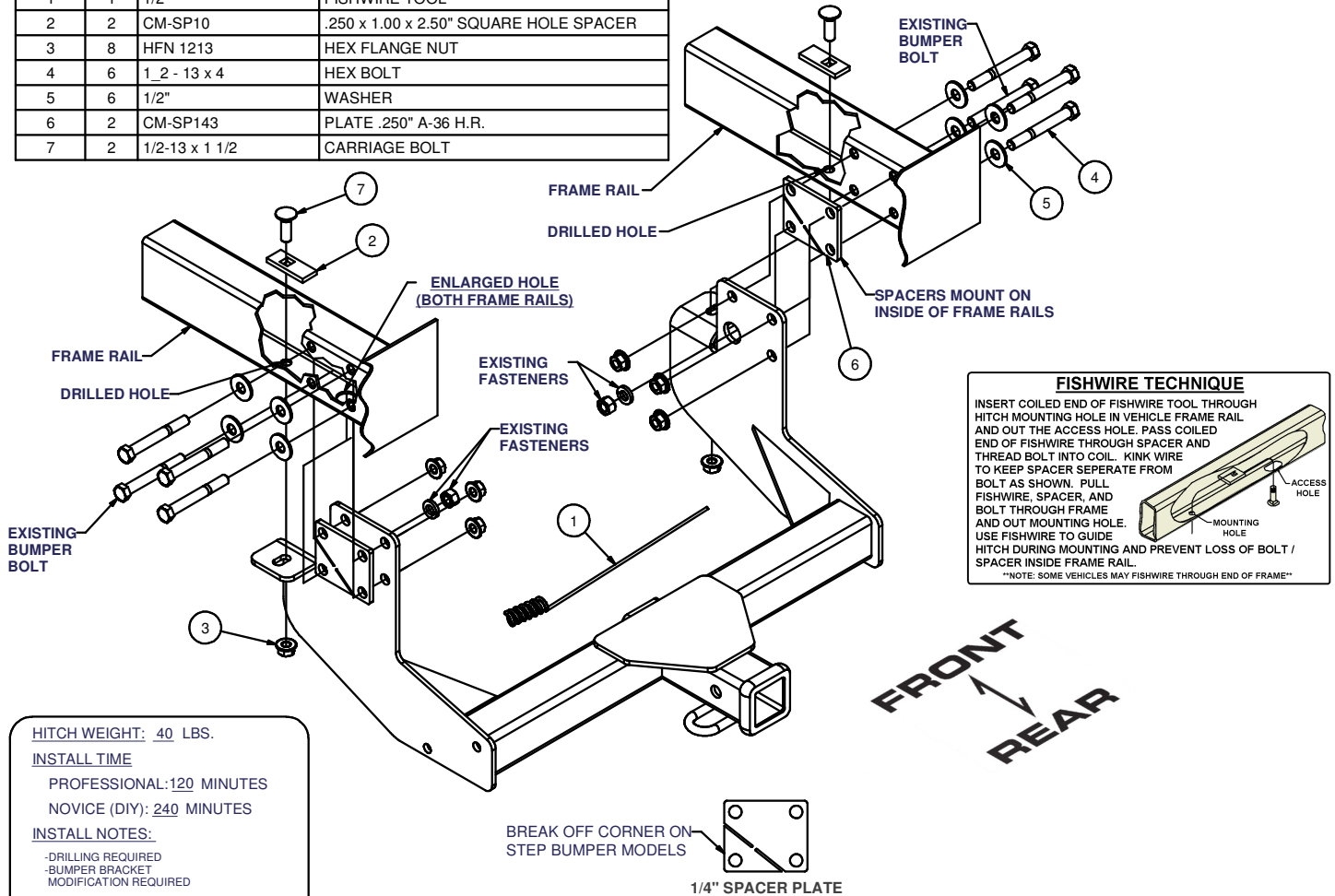

FISHWIRE TECHNIQUE
INSERT COILED END OF FISHWIRE TOOL THROUGH HITCH MOUNTING HOLE IN VEHICLE FRAME RAIL AND OUT THE ACCESS HOLE. PASS COILED END OF FISHWIRE THROUGH SPACER AND THREAD BOLT INTO COIL. KINK WIRE TO KEEP SPACER SEPARATE FROM BOLT AS SHOWN. PULL FISHWIRE, SPACER, AND BOLT THROUGH FRAME AND OUT MOUNTING HOLE. USE FISHWIRE TO GUIDE HITCH DURING MOUNTING AND PREVENT LOSS OF BOLT / SPACER INSIDE FRAME RAIL.
NOTE: SOME VEHICLES MAY FISHWIRE THROUGH END OF FRAME

HITCH WEIGHT: 40 LBS.

INSTALL TIME

PROFESSIONAL: 120 MINUTES

NOVICE (DIY): 240 MINUTES

INSTALL NOTES:

- DRILLING REQUIRED
- BUMPER BRACKET MODIFICATION REQUIRED

BREAK OFF CORNER ON STEP BUMPER MODELS

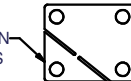

1/4" SPACER PLATE

FRONT
↕
REAR

INSTALLATION STEPS

- 1) Remove (2) existing bumper bolts from each side of the frame.(For step bumper models only.)
- 2) Remove undercoating from mounting surfaces as needed.
- 3) For step bumper models, break off corner of 1/4" spacer plates as shown. Position spacer plates on the inside of frame rails. Raise hitch into position, using existing frame holes, install the 1/2" x 4" hex bolts, flatwashers, and flange nuts. (Note: Do not break off spacer corner for non-step bumper models.)
- 4) Reinstall the bumper bracket fasteners removed in step 1.
- 5) Using hitch as a template, drill (2) 9/16" holes through frame as shown. Enlarge existing holes in bottom of frame rails to 1 1/8".
- 6) Fishwire 1/2" carriage bolts and spacers through enlarged holes and secure with flange nuts.
- 7) Torque all 1/2" fasteners to 110 lb-ft and all M12 fasteners to 86 lb-ft (bumper bracket fasteners).

PERIODICALLY CHECK THIS RECEIVER HITCH TO ENSURE THAT ALL FASTENERS ARE TIGHT AND THAT ALL STRUCTURAL COMPONENTS ARE SOUND.

Curt Manufacturing Inc., warrants this product to be free of defects in material and/or workmanship at the time of retail purchase by the original purchaser. If the product is found to be defective, Curt Manufacturing Inc., may repair or replace the product, at their option, when the product is returned, prepaid, with proof of purchase. Alteration to, misuse of, or improper installation of this product voids the warranty. Curt Manufacturing Inc.'s liability is limited to repair or replacement of products found to be defective, and specifically excludes liability for incidental or consequential loss or damage.