

11610**88-90 MITSUBISHI SIGMA****3/25/2013**

GROSS LOAD CAPACITY WHEN USED AS A WEIGHT CARRYING HITCH: 1,500 LBS. TRAILER WEIGHT & 150 LBS. TONGUE WEIGHT.

*****DO NOT EXCEED VEHICLE MANUFACTURER'S RECOMMENDED TOWING CAPACITY.*****

WARNING: ALL NON-TRAILER LOADS APPLIED TO THIS PRODUCT MUST BE SUPPORTED BY 18050 STABILIZING STRAPS.

**** FAILURE TO PROPERLY SUPPORT NON-TRAILER LOADS WILL VOID PRODUCT WARRANTY****

HAVING INSTALLATION QUESTIONS? CALL TECHNICAL SUPPORT AT 1-800-798-0813

Parts List			
ITEM	QTY	PART NUMBER	DESCRIPTION
1	2	3/8 - 16 x 1 1/4	HEX BOLT
2	2	3/8"	FENDER WASHER
3	6	7/16-14	LARGE HEX FLANGE NUT
4	2	7/16-14 x 1.63 x 2.50 C-C	SQ. U-BOLT

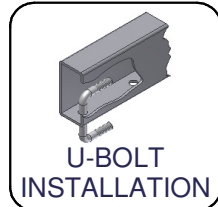
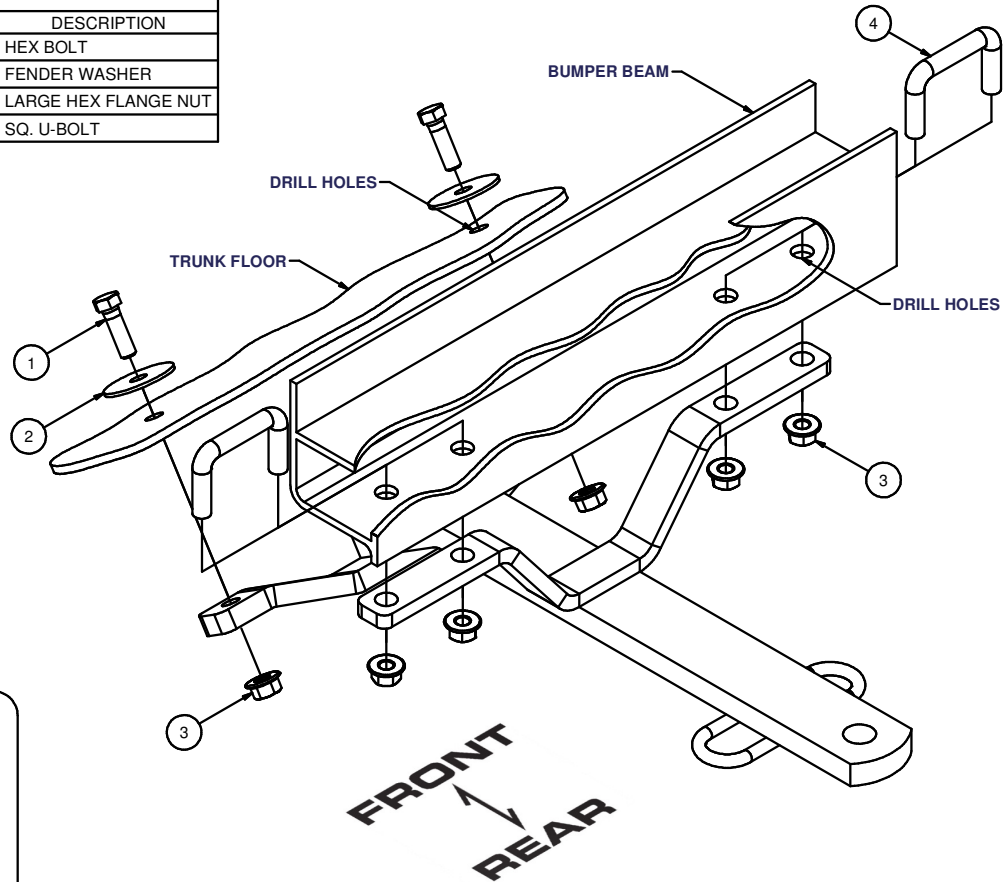

HITCH WEIGHT: 10 LBS.

INSTALL TIME

PROFESSIONAL: 60 MINUTES

NOVICE (DIY): 120 MINUTES

INSTALL NOTES:

- REMOVE SPARE TIRE
- DRILLING REQUIRED
- TRIM BUMPER COVER
- SILICONE HARDWARE

INSTALLATION STEPS

1. Remove spare tire from tire well. Locate vehicle centerline and mark bumper. Cut away the bottom edge of the flexible bumper cover to allow hitch bumper bracket to fit directly against steel bumper. 10 mm fascia screws may have to be removed.
2. Position the hitch on steel bumper and tire well so hitch is centered and level. Using hitch as template, mark and drill bumper (4) places for 7/16" fasteners.
3. Install (2) U-bolts inside the bumper. Mount hitch to the bumper being careful not to push u-bolts back into the bumper. Install hex flange nuts.
4. Drill tire well for 3/8" bolts through bracket of hitch. Fasten hitch using bolts and fender washers opposite the hitch.
5. Torque all 3/8" fasteners to 45 lb-ft and all 7/16" fasteners to 70 lb-ft.
DO NOT USE IMPACT WRENCH ON U-BOLTS.
6. Apply silicone sealant around fasteners in spare tire well to seal out water and exhaust fumes.
7. Reinstall spare tire removed in step 1.

PERIODICALLY CHECK THIS RECEIVER HITCH TO ENSURE THAT ALL FASTENERS ARE TIGHT AND THAT ALL STRUCTURAL COMPONENTS ARE SOUND.

Curt Manufacturing Inc., warrants this product to be free of defects in material and/or workmanship at the time of retail purchase by the original purchaser. If the product is found to be defective, Curt Manufacturing Inc., may repair or replace the product, at their option, when the product is returned, prepaid, with proof of purchase. Alteration to, misuse of, or improper installation of this product voids the warranty. Curt Manufacturing Inc.'s liability is limited to repair or replacement of products found to be defective, and specifically excludes liability for incidental or consequential loss or damage.