

11203**94-97 HONDA ACCORD 2 DR & 4 DR**

10/5/2012

GROSS LOAD CAPACITY WHEN USED AS A WEIGHT CARRYING HITCH: 2,000 LBS. TRAILER WEIGHT & 200 LBS. TONGUE WEIGHT.

*****DO NOT EXCEED VEHICLE MANUFACTURER'S RECOMMENDED TOWING CAPACITY.*******WARNING: ALL NON-TRAILER LOADS APPLIED TO THIS PRODUCT MUST BE SUPPORTED BY AUXILIARY STABILIZING STRAPS.****** FAILURE TO PROPERLY SUPPORT NON-TRAILER LOADS WILL VOID PRODUCT WARRANTY****

HAVING INSTALLATION QUESTIONS? CALL TECHNICAL SUPPORT AT 1-800-798-0813

Parts List			
ITEM	QTY	PART NUMBER	DESCRIPTION
1	6	3/8"	WASHER
2	6	7/16 LOCK WASHER	HELICAL LOCK WASHER
3	6	M10 - 1.25 x 30	HEX BOLT

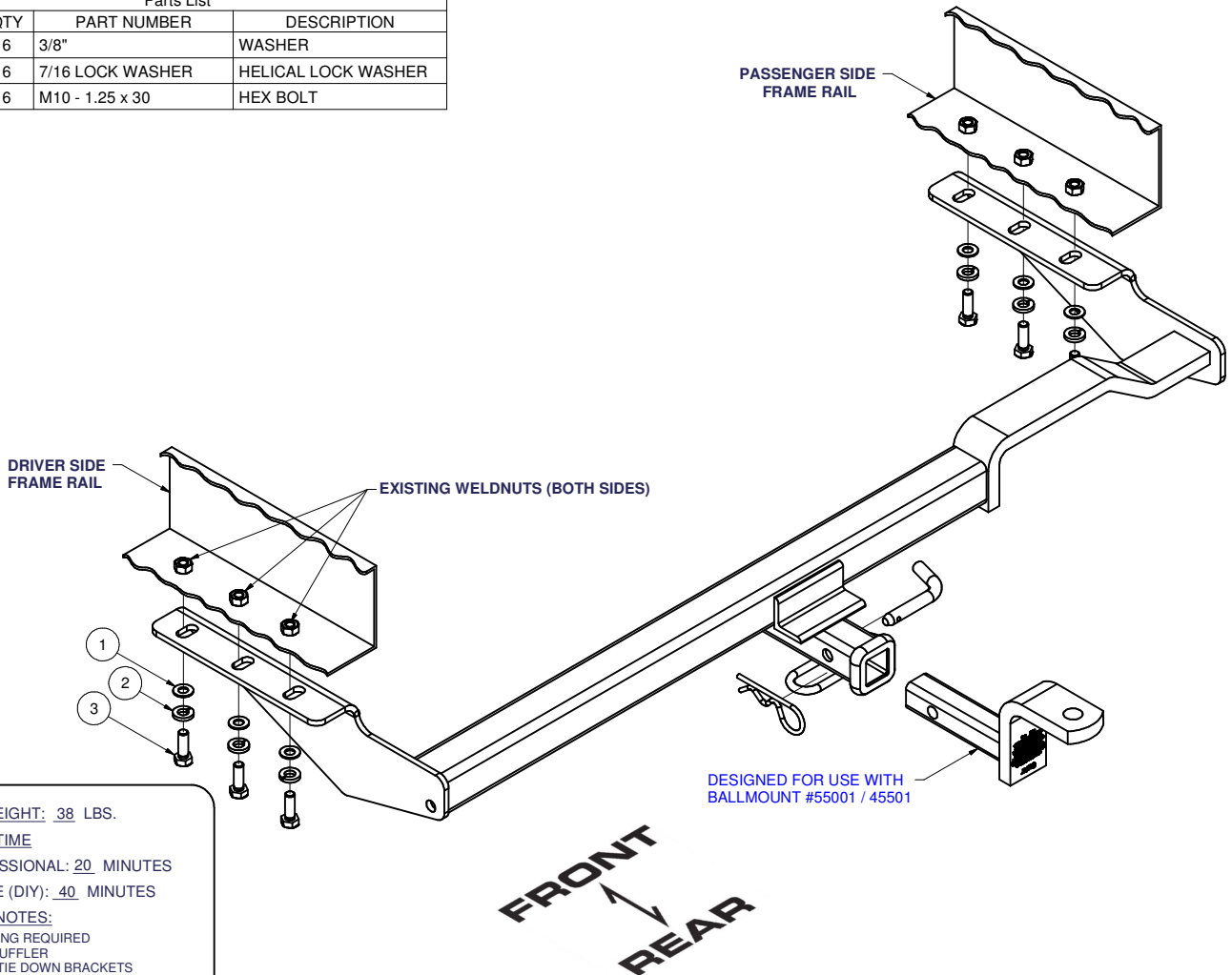

HITCH WEIGHT: .38 LBS.

INSTALL TIME

PROFESSIONAL: 20 MINUTES

NOVICE (DIY): 40 MINUTES

INSTALL NOTES:

- NO DRILLING REQUIRED
- LOWER MUFFLER
- REMOVE TIE DOWN BRACKETS

INSTALLATION STEPS

1. Remove tie down brackets from both rails. Note: Early models may have plastic shields at rear corner of rails which must also be removed. Using a screwdriver, pry plastic shield out. Remove bolt fastening muffler heat shield to bottom of the frame rail. Heat shield tab will be sandwiched between hitch and frame. Return all parts to vehicle owner for reinstallation should hitch be removed.

Note: On '96 models only, remove 4 plastic screws from fascia tabs. Bend 2 center tabs to rest on top of brackets. Reinstall plastic screws in outer tabs only.

2. Lift hitch into position on frame rails, sandwiching heat shield tab. Hitch exhaust bridge must fit over the tailpipe(s). Install fasteners as shown into existing weldnuts.
3. Torque all fasteners to 48 ft-lb.

PERIODICALLY CHECK THIS RECEIVER HITCH TO ENSURE THAT ALL FASTENERS ARE TIGHT AND THAT ALL STRUCTURAL COMPONENTS ARE SOUND.

Curt Manufacturing Inc., warrants this product to be free of defects in material and/or workmanship at the time of retail purchase by the original purchaser. If the product is found to be defective, Curt Manufacturing Inc., may repair or replace the product, at their option, when the product is returned, prepaid, with proof of purchase. Alteration to, misuse of, or improper installation of this product voids the warranty. Curt Manufacturing Inc.'s liability is limited to repair or replacement of products found to be defective, and specifically excludes liability for incidental or consequential loss or damage.