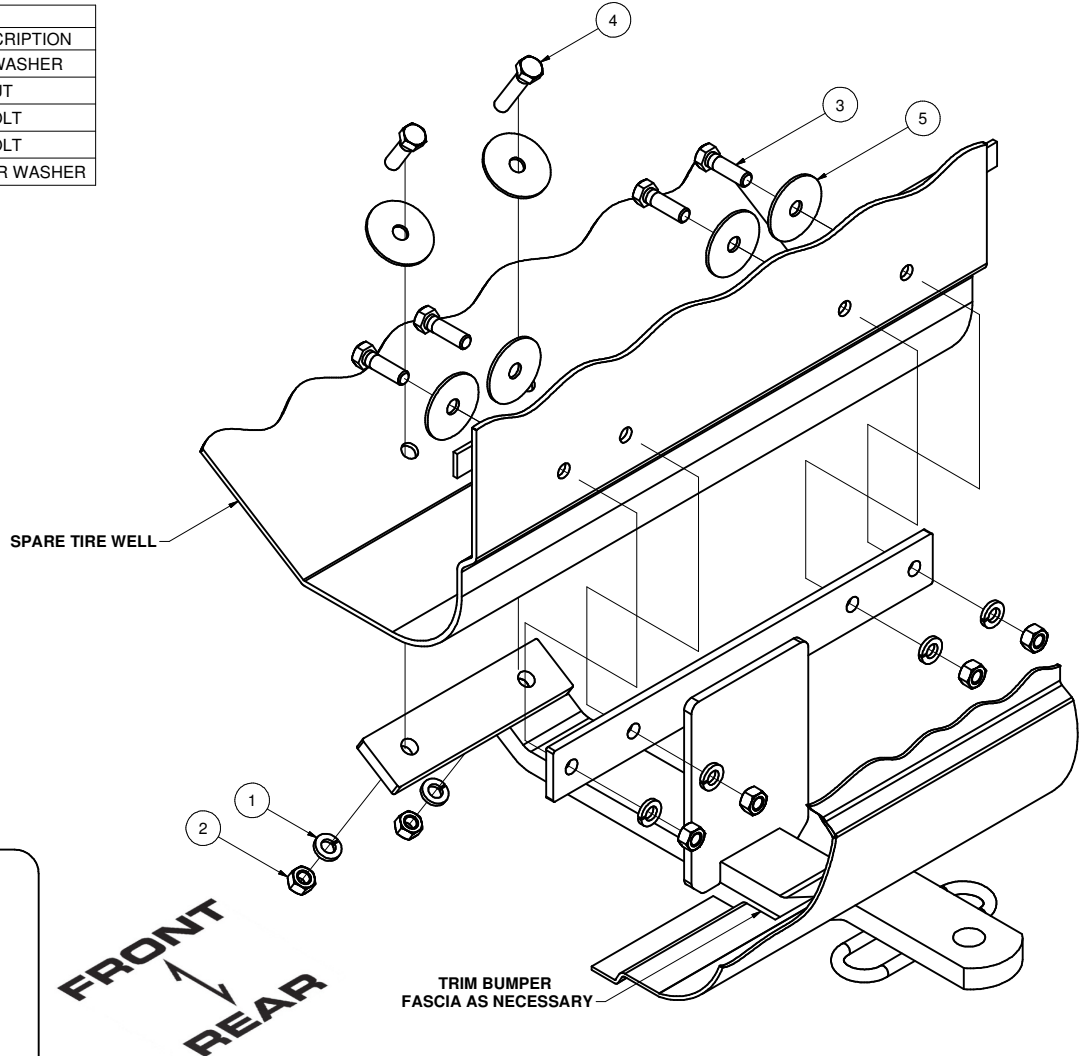

11036**95-01 GEO METRO HATCHBACK
95-01 SUZUKI SWIFT HATCHBACK****1/16/2013****GROSS LOAD CAPACITY WHEN USED AS A WEIGHT CARRYING HITCH: 1,000 LBS. TRAILER WEIGHT & 100 LBS. TONGUE WEIGHT.*******DO NOT EXCEED VEHICLE MANUFACTURER'S RECOMMENDED TOWING CAPACITY.*******WARNING: ALL NON-TRAILER LOADS APPLIED TO THIS PRODUCT MUST BE SUPPORTED BY 18050 STABILIZING STRAPS.****** FAILURE TO PROPERLY SUPPORT NON-TRAILER LOADS WILL VOID PRODUCT WARRANTY******HAVING INSTALLATION QUESTIONS? CALL TECHNICAL SUPPORT AT 1-800-798-0813**

Parts List			
ITEM	QTY	PART NUMBER	DESCRIPTION
1	6	3/8"	LOCK WASHER
2	6	3/8 - 16	HEX NUT
3	5	3/8 - 16 x 1 1/4	HEX BOLT
4	1	3/8 - 16 x 1 3/4	HEX BOLT
5	6	3/8"	FENDER WASHER

**HITCH WEIGHT: 11 LBS.****INSTALL TIME**PROFESSIONAL: 45 MINUTESNOVICE (DIY): 90 MINUTES**INSTALL NOTES:****- DRILLING REQUIRED****INSTALLATION STEPS**

- 1) This hitch will bolt to the vertical panel just forward of the bumper and the bottom (outside) of the spare tire well as shown. Temporarily clear the trunk and remove the spare tire for access. Position the hitch centered and level on the car as shown. Lower hitch.
- 2) Holes for hitch rear bracket will be drilled in the body rib from the **INSIDE** of the car's trunk. Mark, center punch and drill (4) 13/32" diameter holes in the body rib. Bolt the hitch in place at the body rib using fasteners as shown.
- 3) Using the hitch as a template, drill holes through the tire well. Bolt the hitch in place and install fasteners as shown. Make certain the large fender washers are used inside the car; opposite the hitch in six places.
- 4) Torque all 3/8" fasteners to 45 ft-lbs.

PERIODICALLY CHECK THIS RECEIVER HITCH TO ENSURE THAT ALL FASTENERS ARE TIGHT AND THAT ALL STRUCTURAL COMPONENTS ARE SOUND.

Curt Manufacturing Inc., warrants this product to be free of defects in material and/or workmanship at the time of retail purchase by the original purchaser. If the product is found to be defective, Curt Manufacturing Inc., may repair or replace the product, at their option, when the product is returned, prepaid, with proof of purchase. Alteration to, misuse of, or improper installation of this product voids the warranty. Curt Manufacturing Inc.'s liability is limited to repair or replacement of products found to be defective, and specifically excludes liability for incidental or consequential loss or damage.