

Installation Manual

1973-79 Ford Pickup *Factory Air*

DOCUMENT #1-2095FA

©2019 Classic Auto Air / 10.19





Congratulations...

You have just purchased the highest quality, best performing A/C system ever designed for your 1973-79 Ford Pickup.

To obtain the high level of performance and dependability our systems are known for, please pay close attention to the following instructions. Our installation steps and procedures are derived from a long history of research and development and the combined experience achieved thru thousands of successful installations (and feedback from customers like you). Please remember that our #1 goal is that you'll have a successful installation and a system that performs at a very high level for many years to come.

Before starting, read the instructions carefully, from beginning to end, and follow the proper sequence. On the next page you'll find a safety and general checklist that you should read before starting your installation.

Again, thank you from our entire staff.



Check List, Pre-Installation:

- Before beginning the installation check the shipping box for the correct components. YOUR BOXED UNIT INCLUDES A LIST OF MAJOR COMPONENTS AND A LIST OF BAGGED PARTS. We have a 5 stage check process to make sure you have everything you'll need.
- If your vehicle has been or is being modified, some procedures will need to be adjusted to fit your particular application.**
- A basic cleaning of the engine compartment and interior before beginning will make things go more smoothly.
- Check condition of engine mounts. Excessive engine movement can damage hoses to A/C and/or heater.
- Before starting, check vehicle interior electrical functions (interior lights, radio, horn, etc). Make a note of anything that does not work as it's supposed to. During the installation you might find the opportunity to repair or upgrade non-working or out of date components. When you're ready to start the installation, **DISCONNECT THE BATTERY FIRST.**
- Drain the radiator. Retain the coolant and reuse, or dispose of properly.
- SAFETY FIRST: Wear eye protection while drilling/cutting, deburr sharp edges, and never get in a hurry or force a part.
- Tools: Your installation only requires the basic tools everyone has in their garage, nothing exotic or specific to A/C or Heat equipment.

Procedures, During Installation:

- Fittings: Use one or two drops of mineral oil (supplied with your kit) on ALL rubber o-rings, threads and rear of bump for o-ring where female nut rides. Do not use thread tape or sealants.
- Measure twice (or more), cut once
- Should you have any technical questions, or feel you have defective components (or missing items), call us immediately, we will be glad to assist you. Our toll-free number is listed on every page, we're here to help!**

YOU CAN NOW BEGIN THE INSTALLATION...

A Basic Overview of Automotive A/C....

- 1 **Evaporator with Blower Fan** In order to remove the heat from the air in the vehicle, the A/C evaporator allows the refrigerant to absorb the heat from the air passing over it. The blower fan moves cool air out into the car interior.
- 2 **Compressor** The compressor pumps and circulates the refrigerant through the system.
- 3 **Condenser** The condenser is a heat exchanger mounted at the front of the vehicle. Heat drawn out of the interior of the car is expelled here.
- 4 **Receiver/Drier** The drier not only dries refrigerant, it also filters the refrigerant and stores it under certain operating conditions.
- 5 **High Pressure Switch** A pressure switch is used to shut down the system if high or low pressure is detected, basically it acts as a safety switch.

The air conditioning system in your vehicle is comprised of a compressor, condenser, expansion valve, receiver/drier, and evaporator. Refrigerant (also known as Freon) is compressed in the compressor. In the condenser, gas is cooled to a liquid state and travels to the expansion valve. As the liquid refrigerant goes through the expansion valve it rapidly cools in the evaporator. A fan blows over the evaporator and cools the air that blows out your vents.

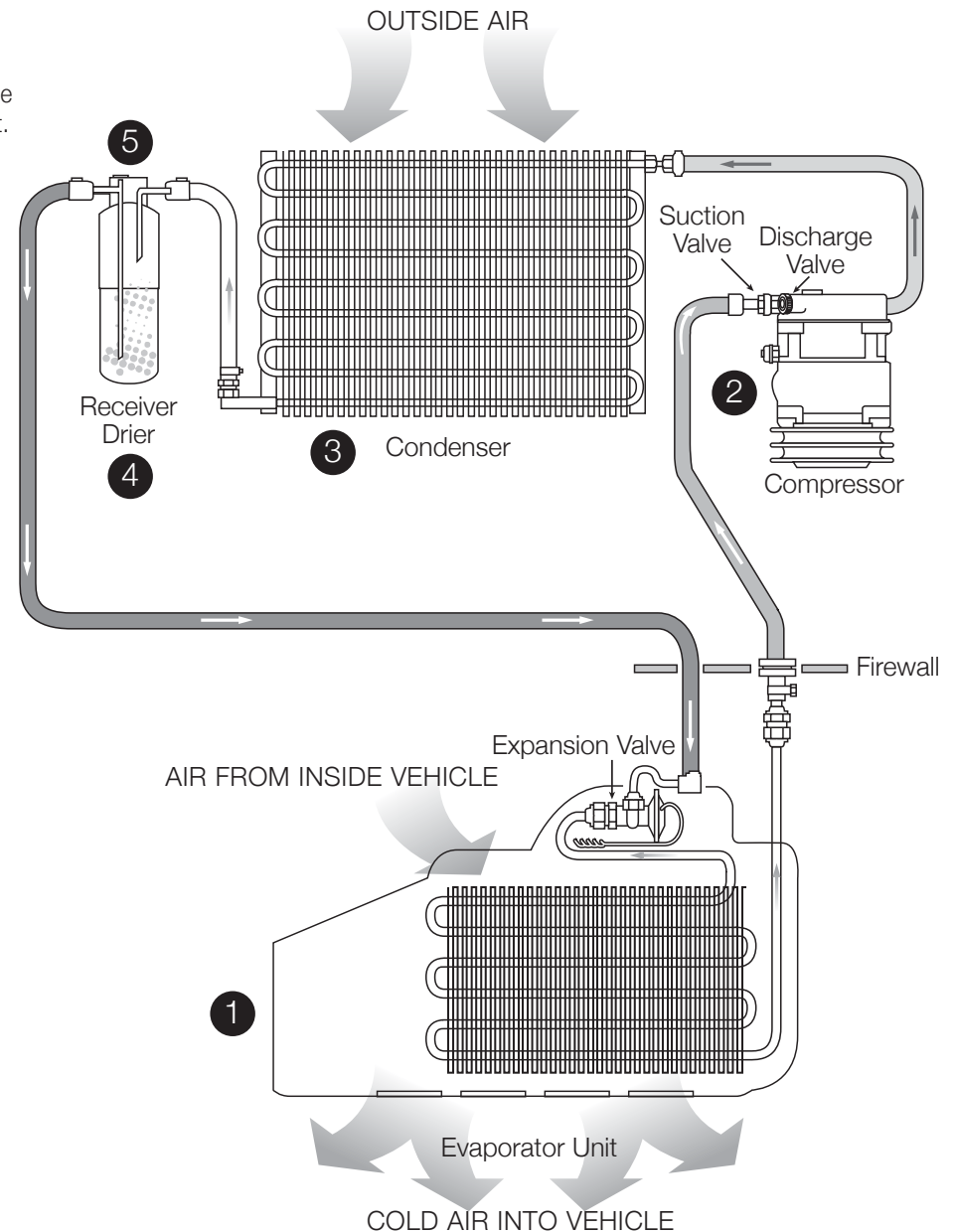



Control & Operating Instructions

Your new **Perfect Fit-Elite system** offers complete comfort capabilities in virtually every driving condition. This includes temperature control in all of the modes. This system also provides the ability to blend the air between Face, Heat, and Defrost modes simultaneously. To illustrate the various ways you can adjust the airflow direction and temperature - we've provided these handy illustrations and chart to show exactly how you can adjust your **Perfect Fit-Elite** for maximum comfort...

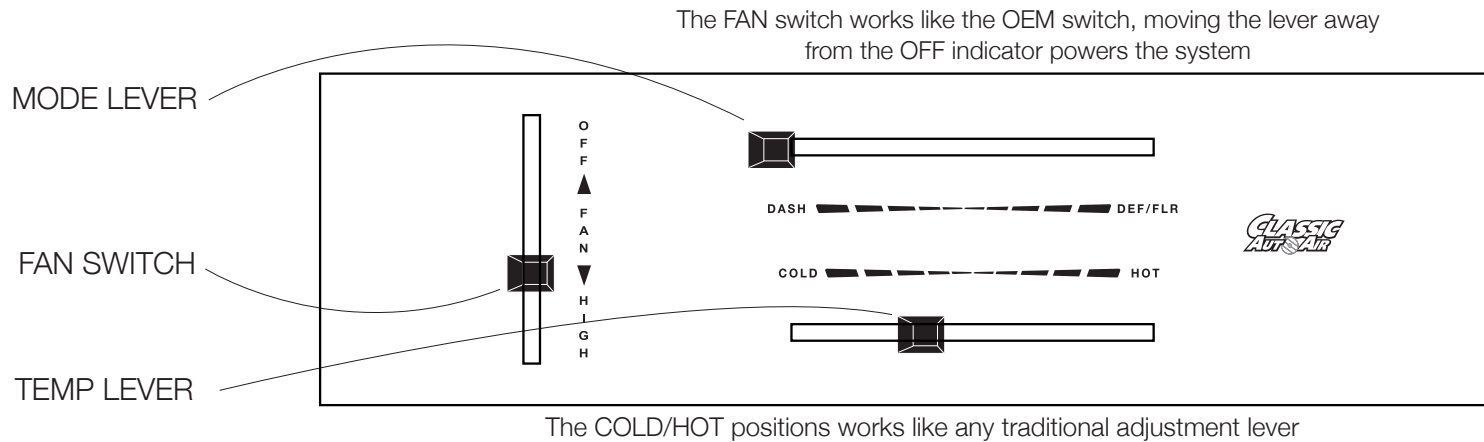

There are 11 levels of adjustment within the range of the DASH/DEF lever

	DASH										DEF/ FLOOR
Left Lever Position	1	2	3	4	5	6	7	8	9	10	11
Distribution	Dash 100%	Dash 90%	Dash 80%	Dash 70%	Dash 60%	Dash 50%	Dash 40%	Dash 30%	Dash 20%	Dash 10%	Floor 100%
		Defrost/Floor 10%	Defrost/Floor 20%	Defrost/Floor 30%	Defrost/Floor 40%	Defrost 50%	Defrost 60%	Defrost 70%	Defrost 80%	Defrost 90%	Defrost 100%
Compressor State	ON										ON

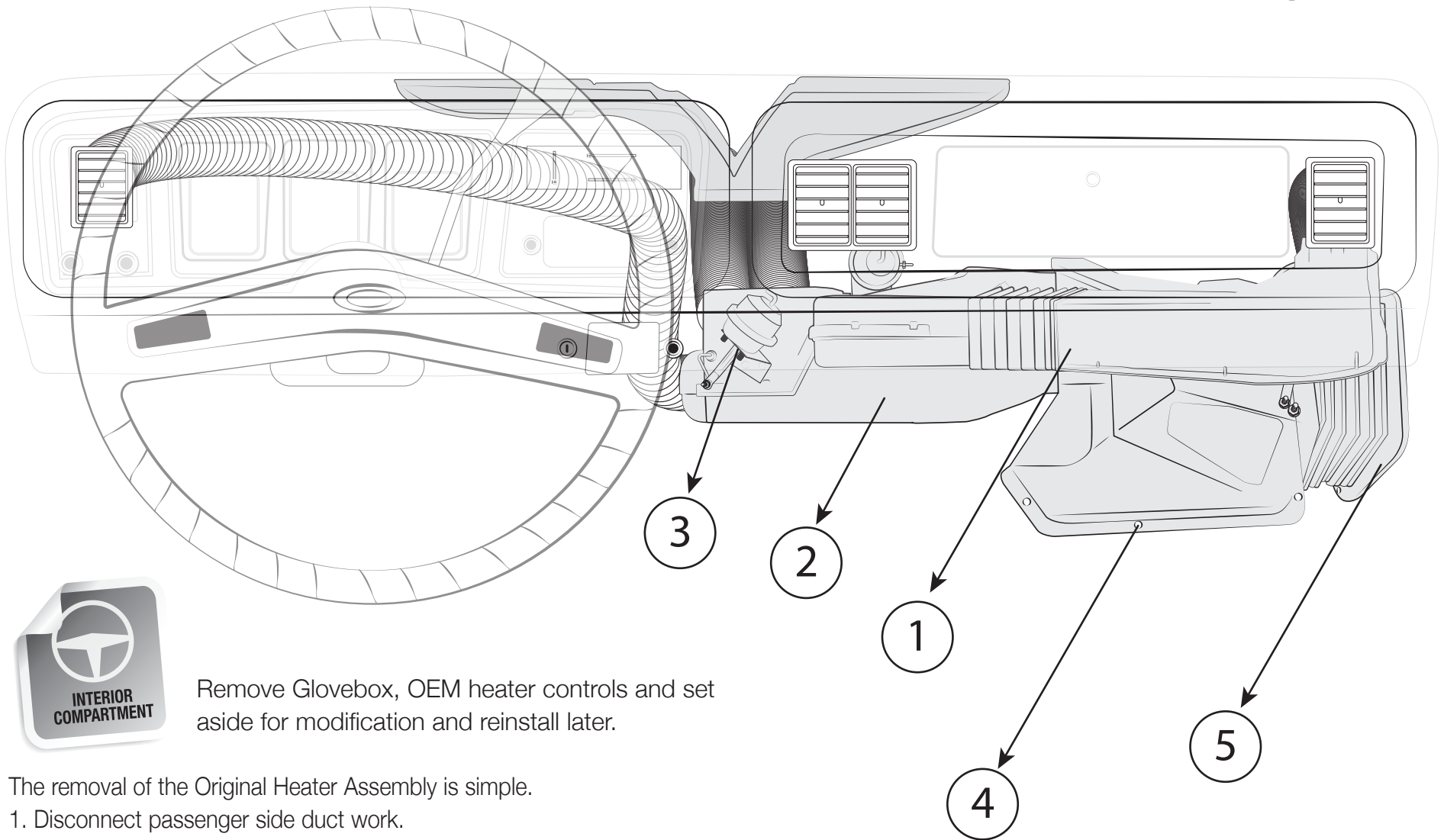

Remove Glovebox, OEM heater controls and set aside for modification and reinstall later.

The removal of the Original Heater Assembly is simple.

1. Disconnect passenger side duct work.
2. Disconnect defrost duct work.
3. Disconnect the electrical harness from the assembly.
4. Remove interior heater box.
5. Remove attachment screws located in front of the air inlet.

FIGURE 7

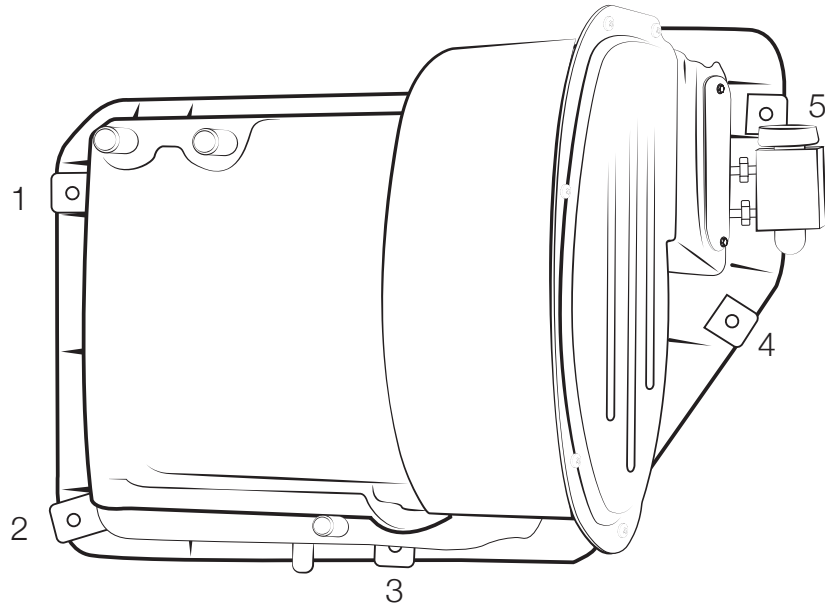

Moving to the engine compartment:

In order to remove your heater assembly it is necessary to remove the heater case housing first.

Located on the engine side of the firewall, remove seven (5) bolts around the perimeter of the heater case housing (see Figure 7). Remove the housing (Discard). Drain coolant from radiator. Remove the heater hoses from heater coil and firewall.

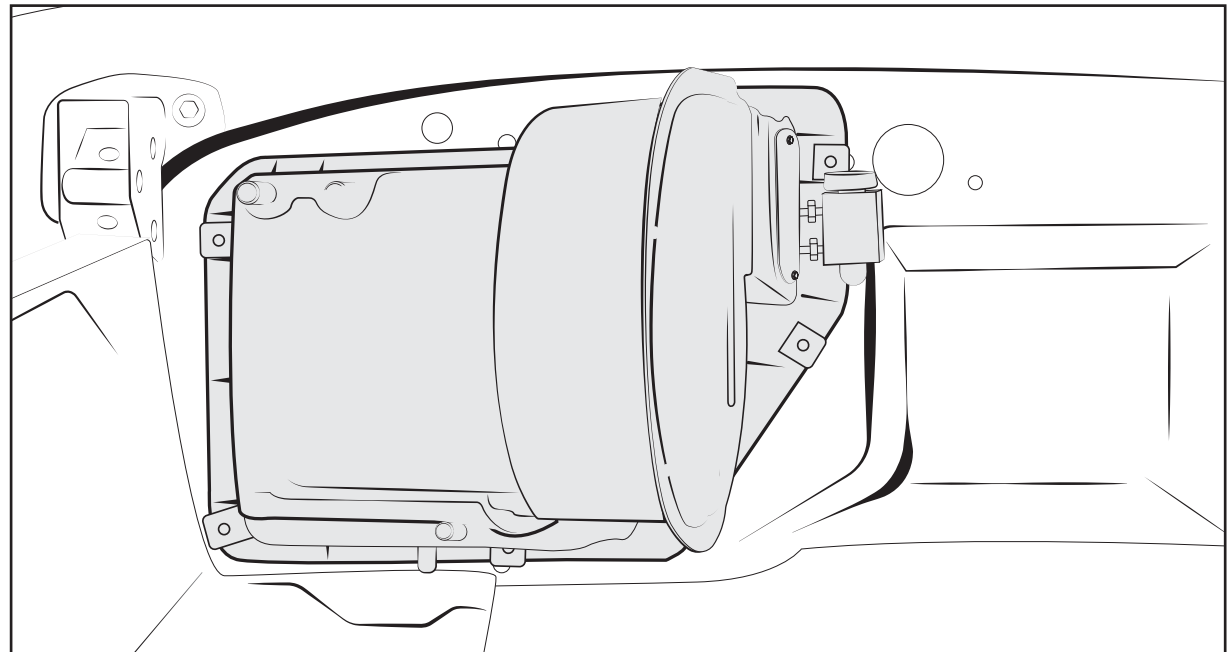

THESE ARE THE PARTS YOU WILL FIND IN BAG KIT A

(D.E.R. Controller)

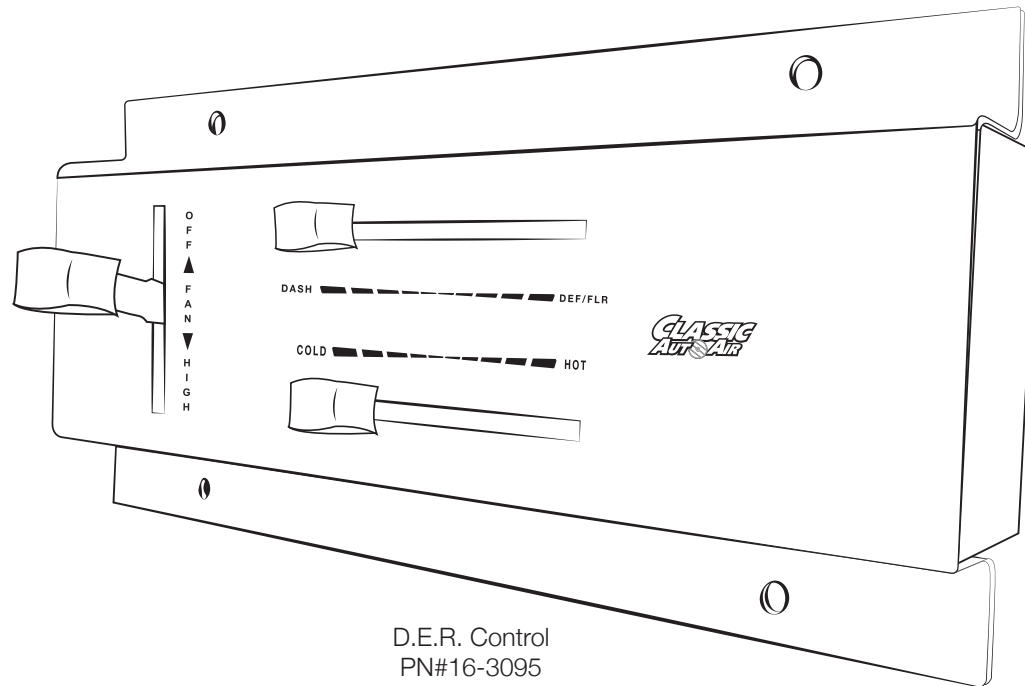

D.E.R. Control
PN#16-3095

THESE ARE THE PARTS YOU WILL FIND IN BAG KIT B

You will use all of these parts and hardware during the next series of installation steps.

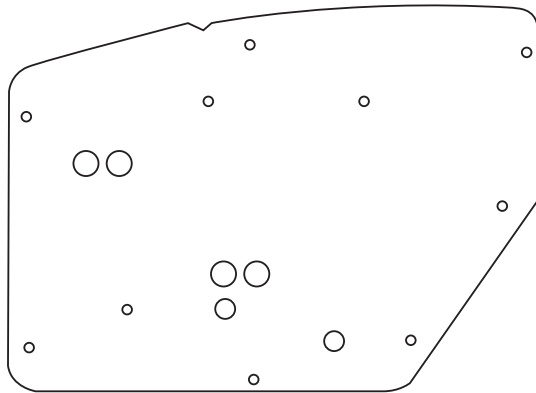

Firewall Block Off
PN#10-2095FA-2

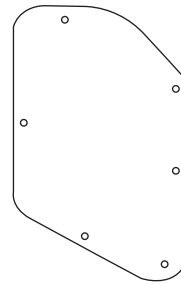

Fresh Air Block Off
PN#10-2095FA-1

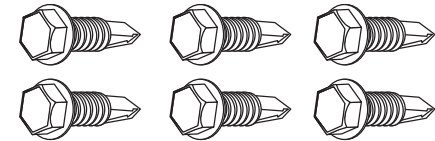

Six #14 - 16 x 3/4" Tek Screws

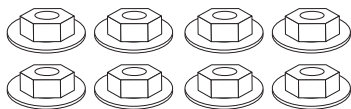

Flange Nuts

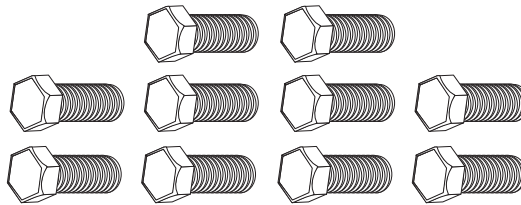

Ten 1/4-20 x 5/8" Hex Head Bolts



Two #10 x 5/8" Phillips Screws

Illustrations NOT shown actual size

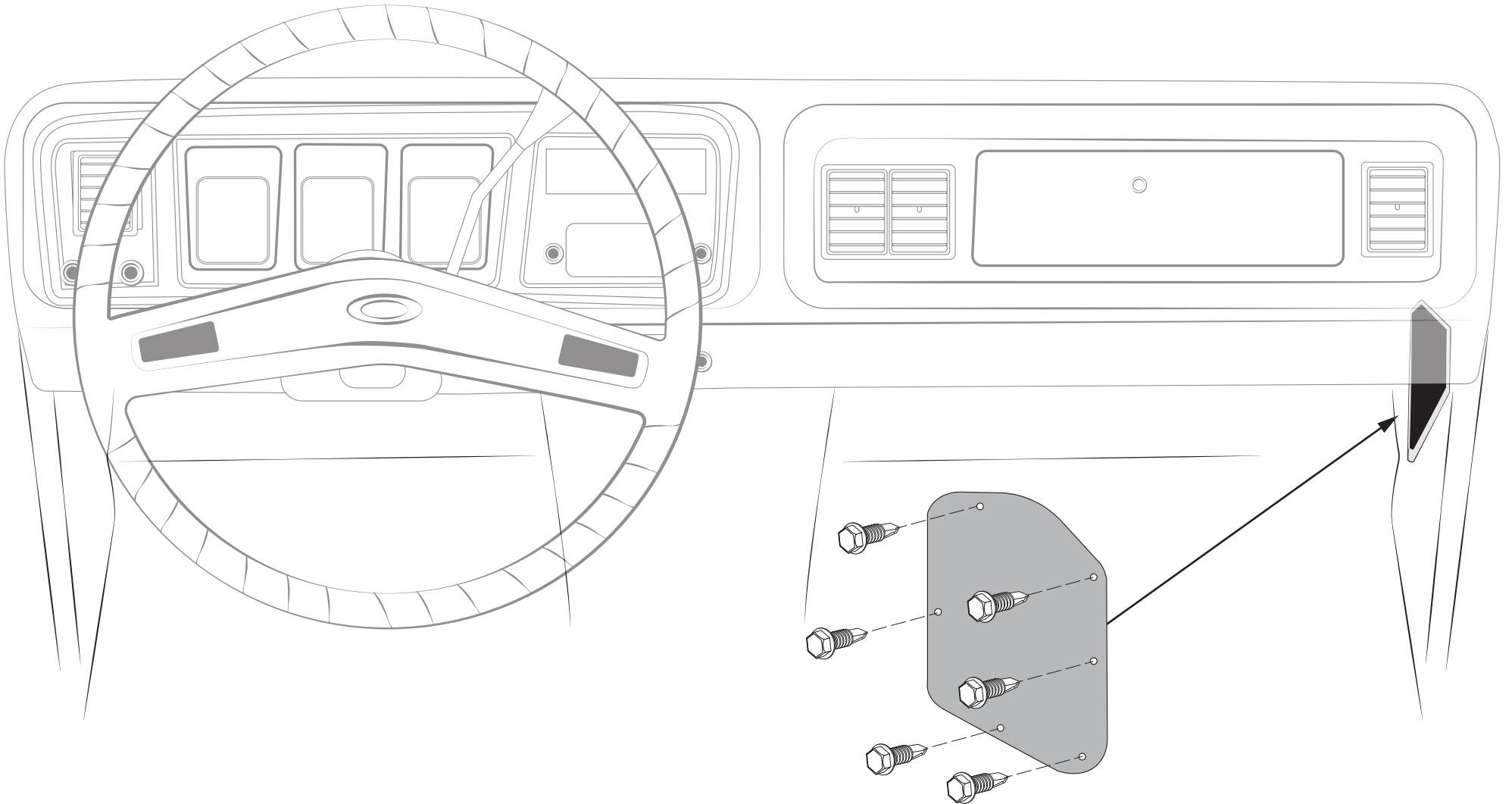

Attach Fresh Air Block Off Plate PN#10-2095FA-1
to firewall using Six Tek Screws provided in Bag Kit

Attach Firewall Block Off Plate PN# 10-2095FA-1 to firewall using Four 1/4 - #20 x 5/8" bolt and (7) Flanged Nuts provided in Bag Kit B.

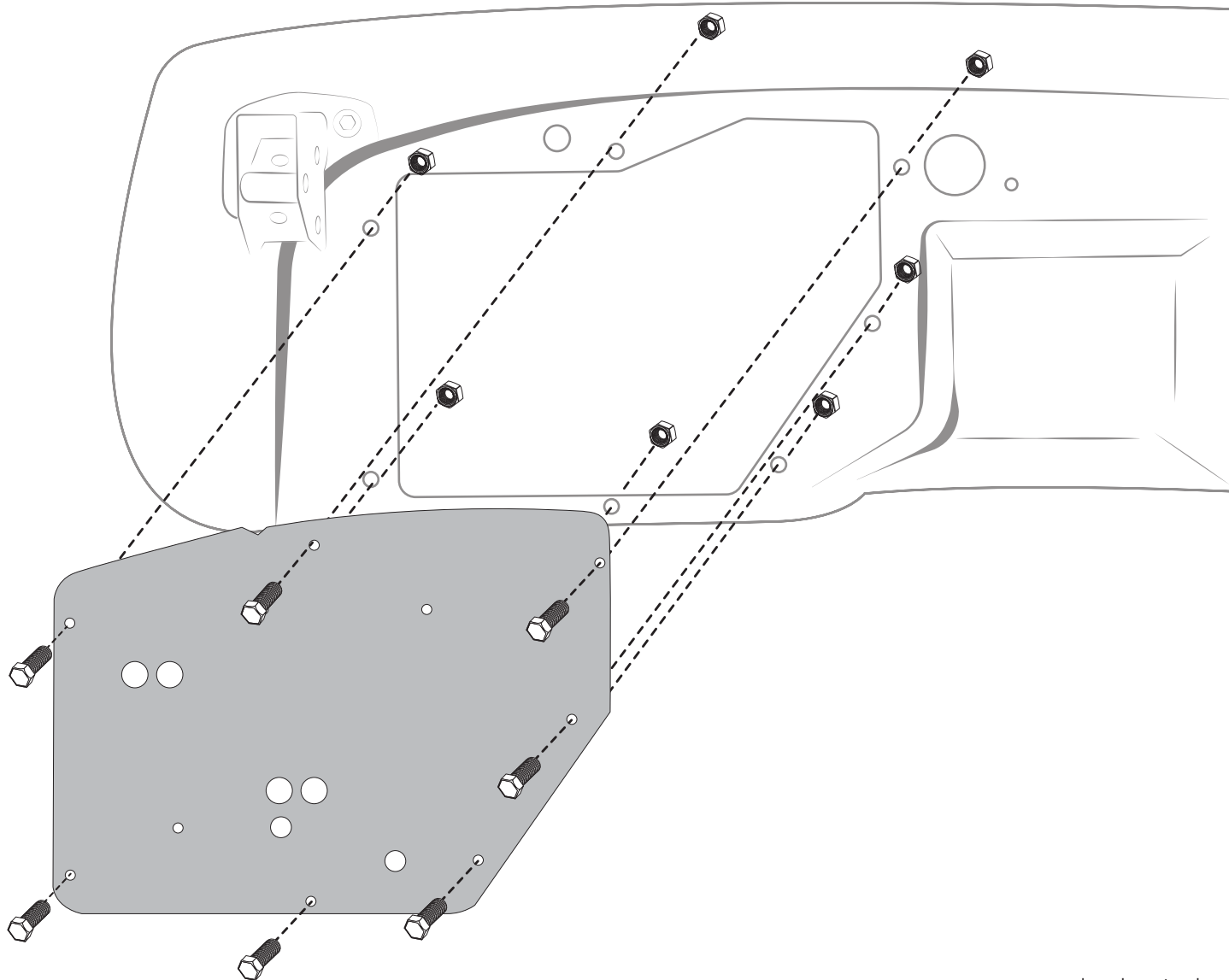

Remove Evaporator Unit and Defrost Assembly from box. The Defrost Assembly is pre-installed using Two #10 x 5/8" Phillips Screws.

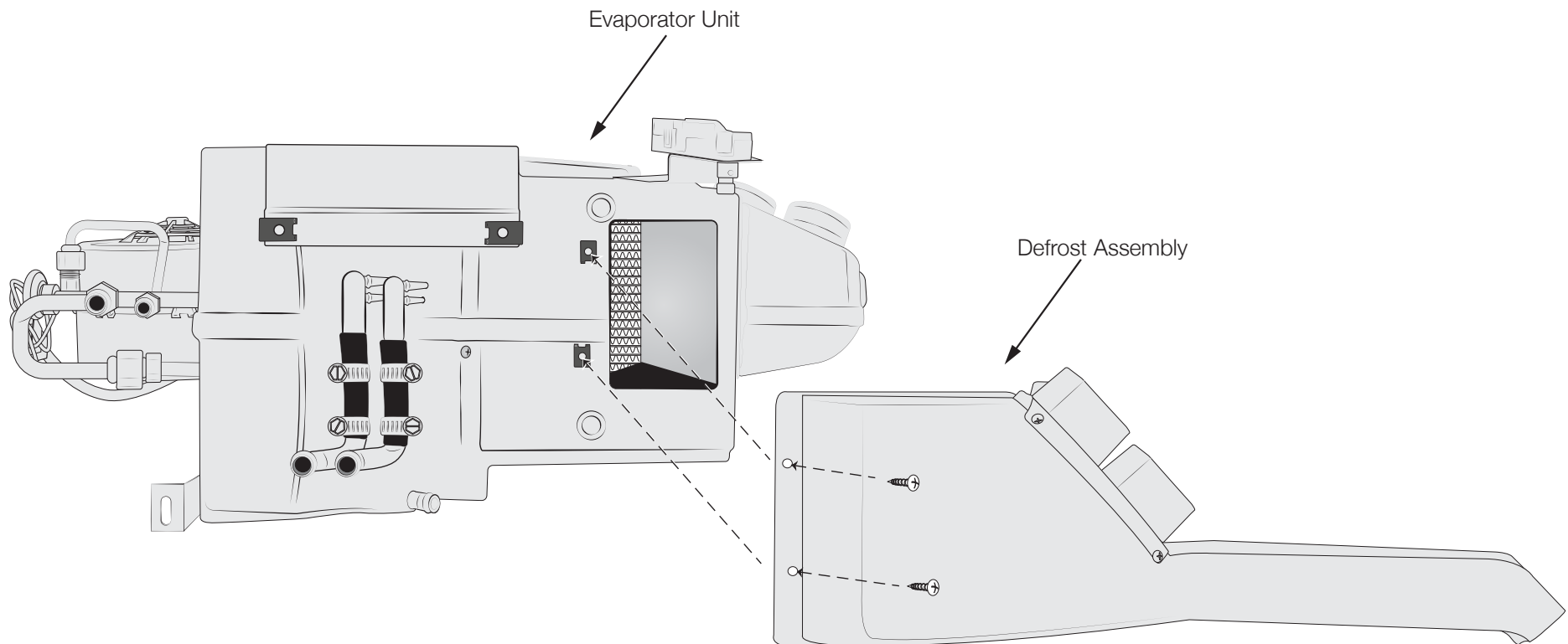

Note: The Defrost adapter will have slight movement until it is installed, pressure of installation will make it stable.

Pre-installed Face Duct Assembly

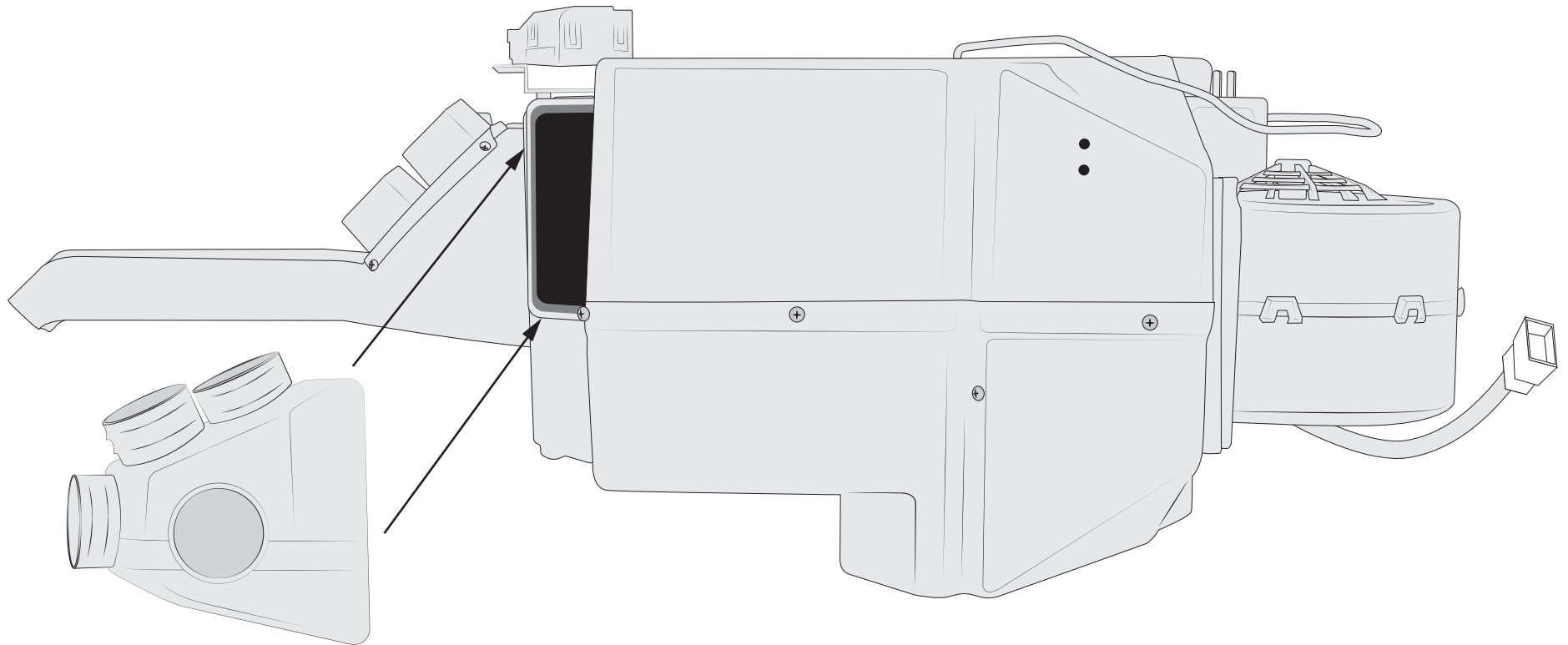

Take a minute to familiarize yourself with the evaporator unit:

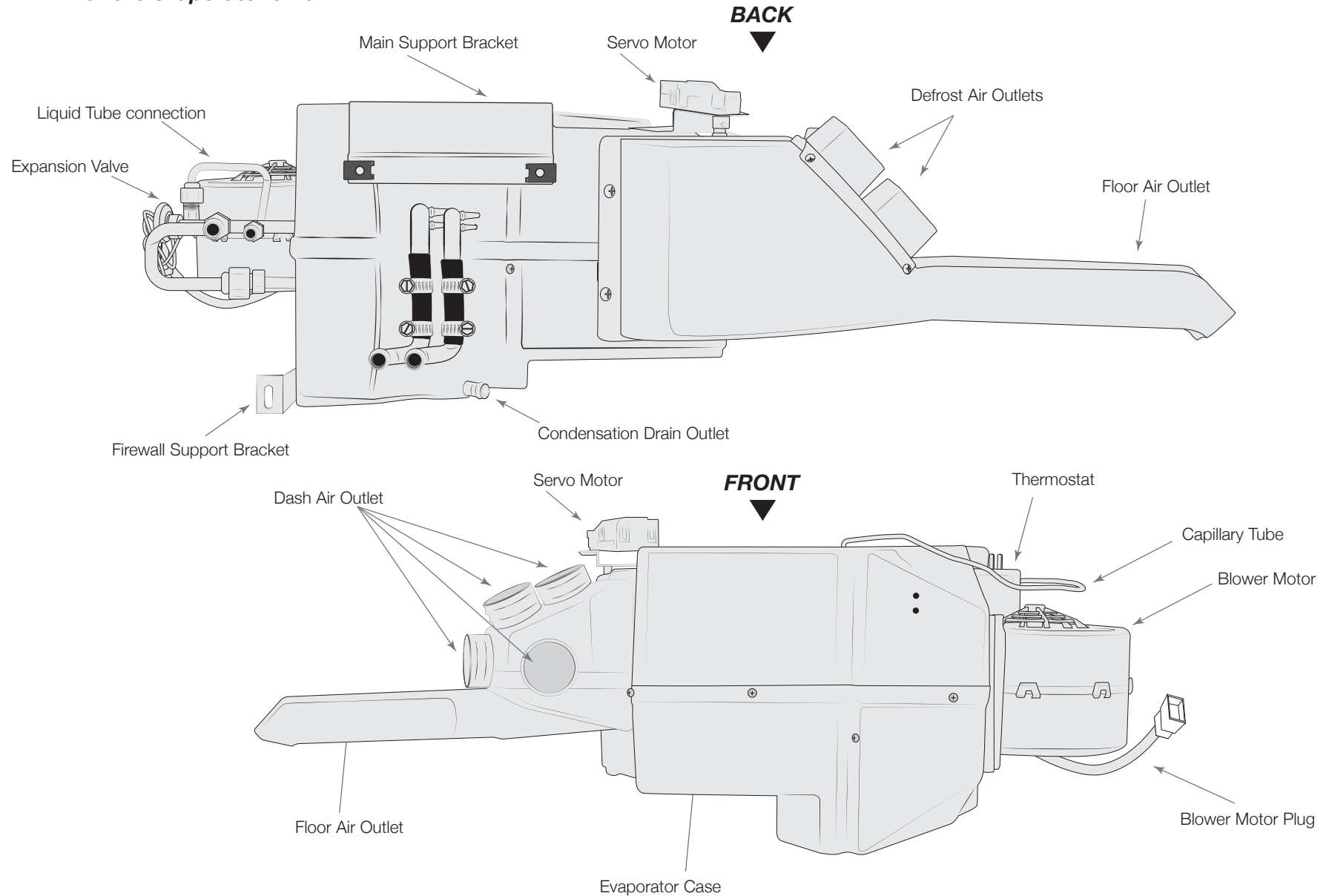

WIRING PREP

• Items Needed for Bench Calibration

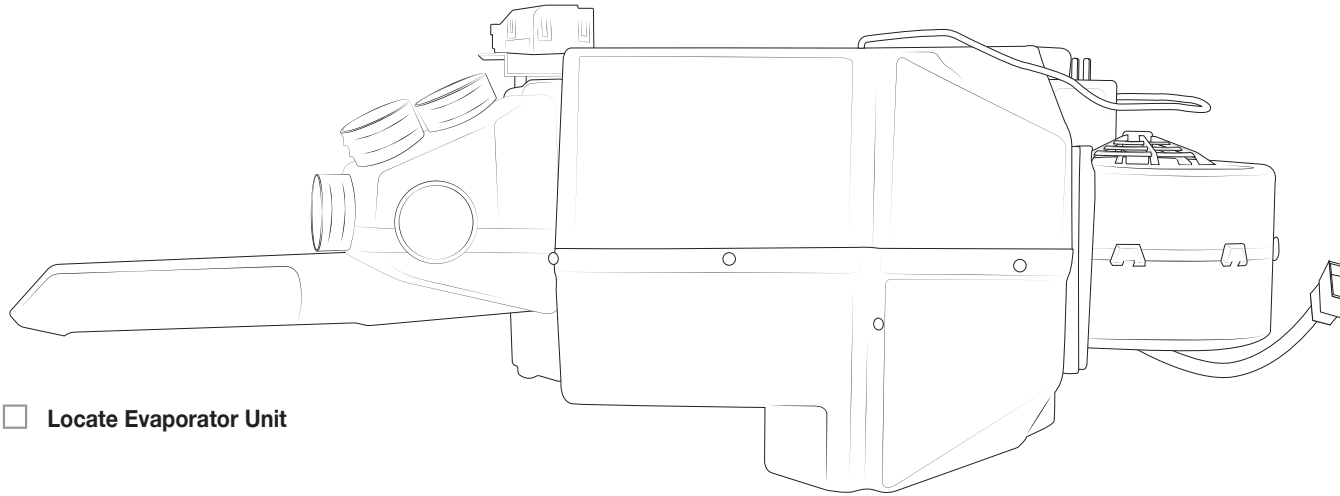

Locate Evaporator Unit

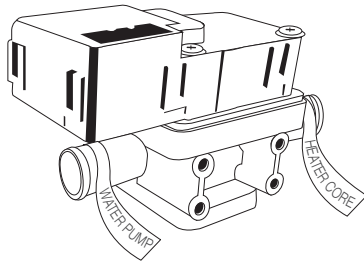

Locate electronic water valve from Bag Kit D

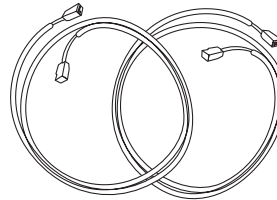

Locate Yellow, Orange wiring harness from Bag Kit C

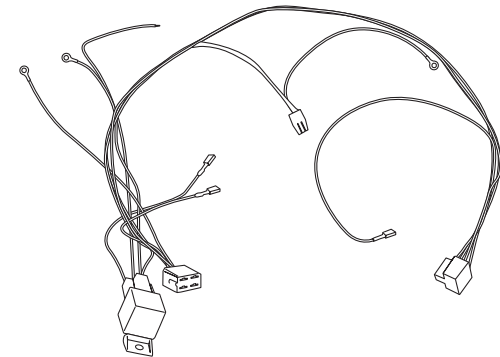

Locate main wiring harness from Bag Kit C

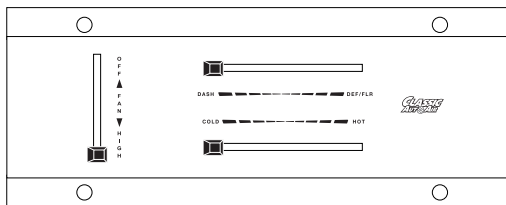

Locate the D.E.R. controller in the CONTROL BOX



Locate ECU and Calibration Key from Bag Kit C
DO NOT USE CALIBRATION KEY WITHOUT TECHNICAL SUPPORT

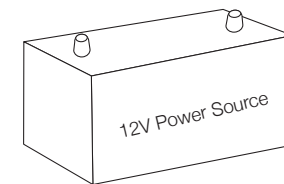

Acquire a 12V Battery (NOT a battery charger)

WIRING PREP

• Wiring Preparation Steps 1 and 2

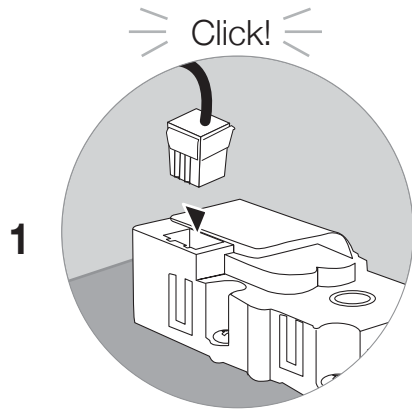

Connect Yellow Harness into Face/Floor Servo Motor

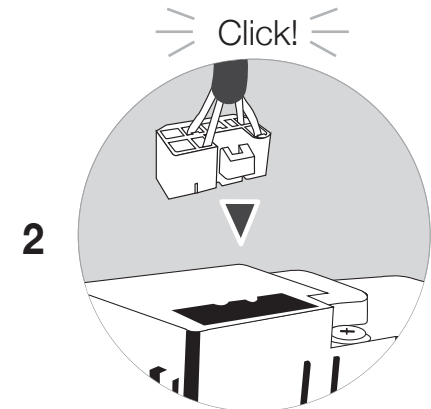
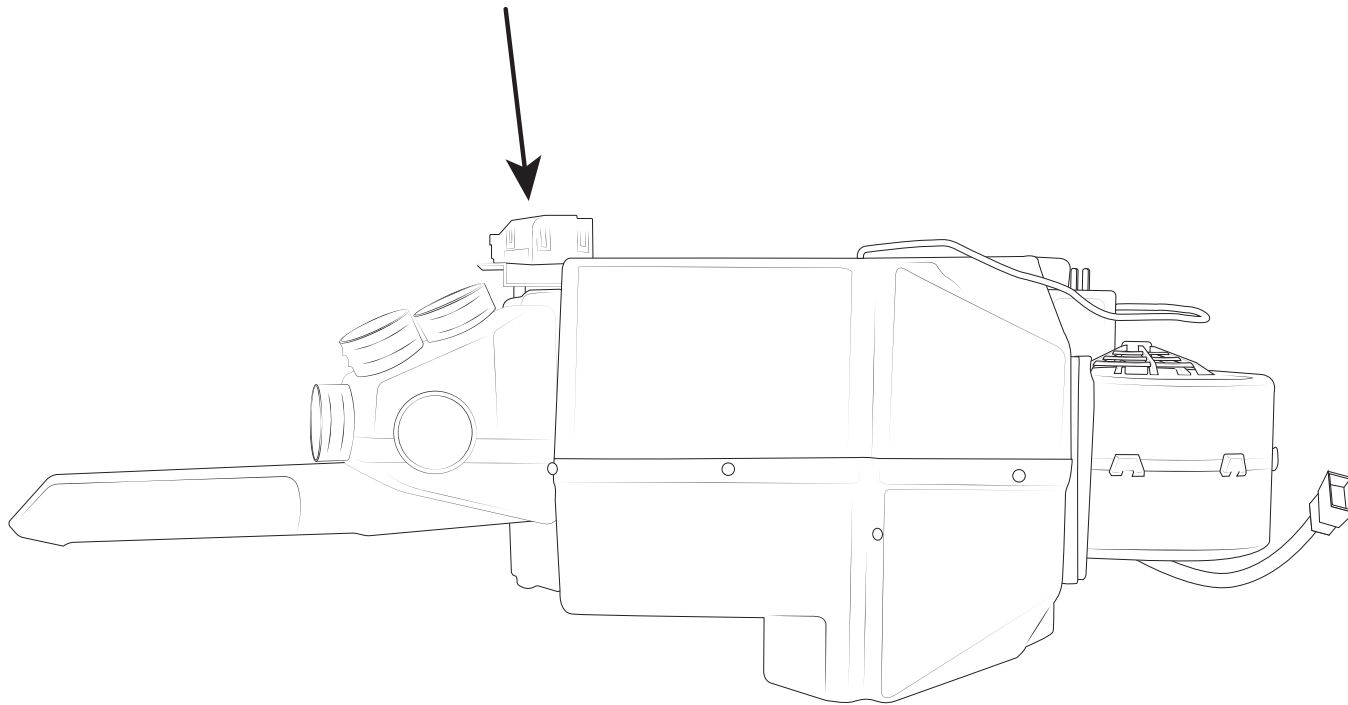

Connect Orange Harness into water valve

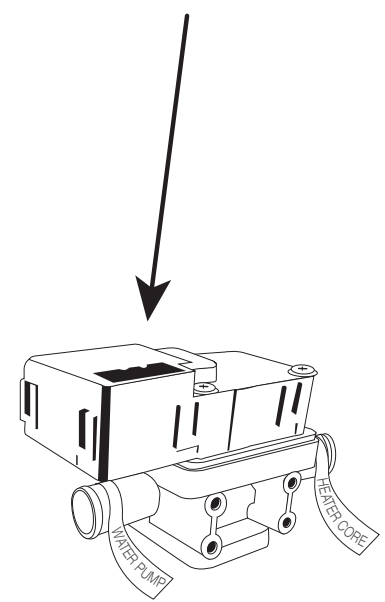

WIRING PREP

• Wiring Preparation Steps 3 thru 5

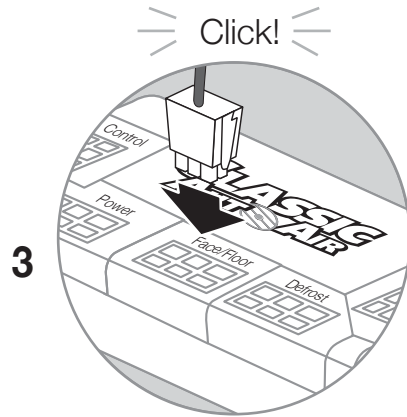

Connect Yellow Harness into Face/Floor Port on ECU

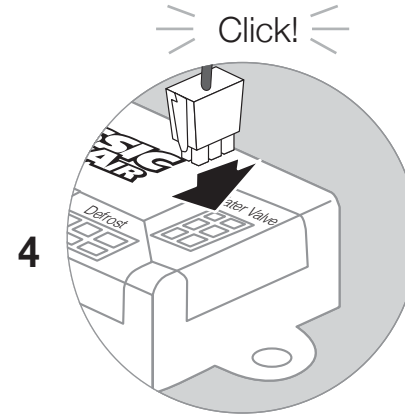

Connect Orange Harness into Water Valve Port on ECU

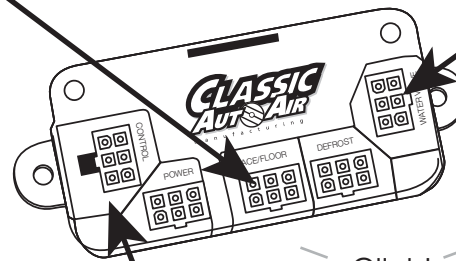

From your D.E.R.,
Connect Green Harness into
Control Port on ECU

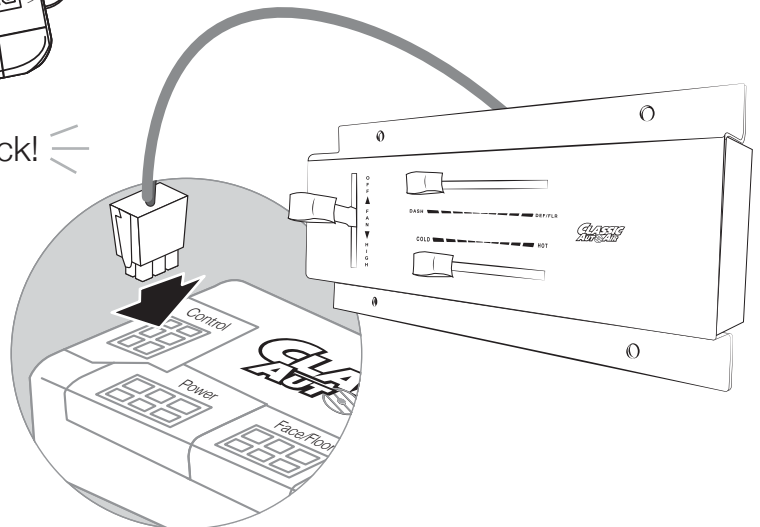

WIRING PREP

• Wiring Preparation Steps 6 through 10

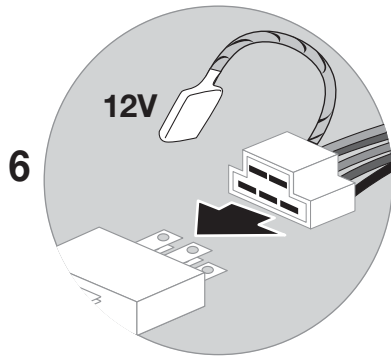

Connect corresponding fan switch harness to the blower switch on controls connect power lead to 12V.

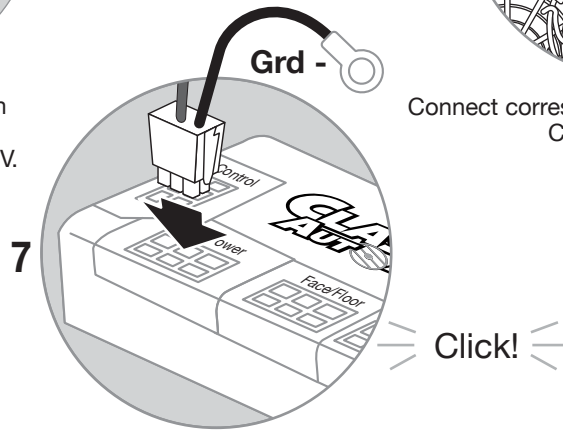

Connect red tagged power harness to POWER port on ECU.
Connect ground.

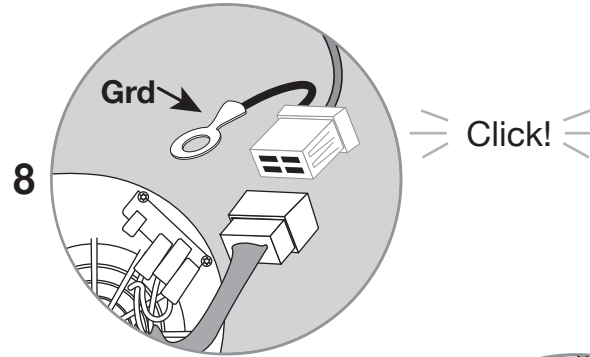

Connect corresponding fan motor harness.
Connect ground.

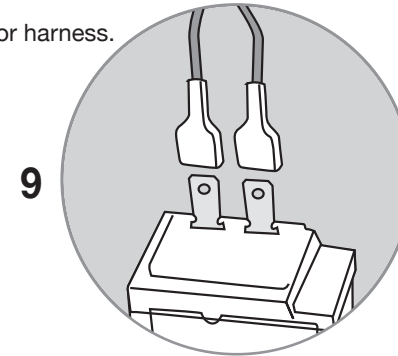

Connect both BLUE leads into thermostat
(either lead into either terminal)

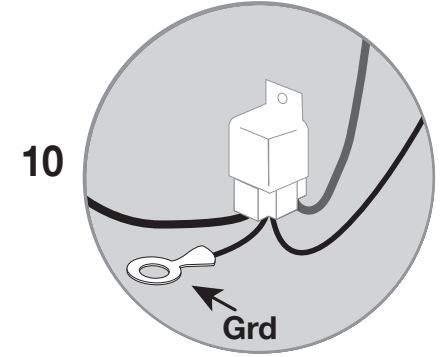

Connect ground.

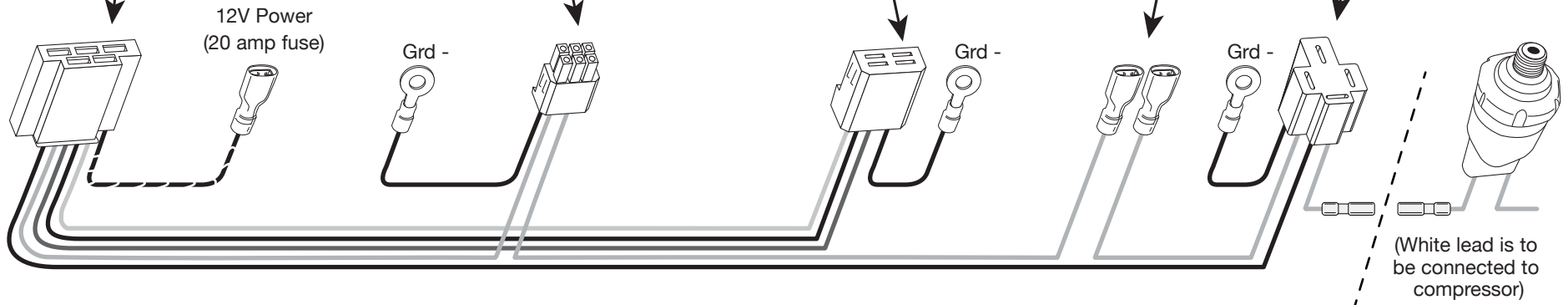

FUNCTION TESTING

• Function Test, Steps 1 thru 3

1

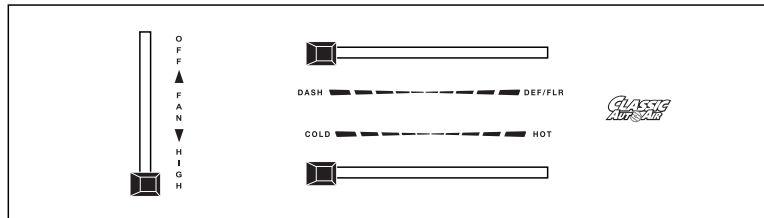

Move FAN knob to HIGH
Move MODE knob to DASH
Move TEMP knob to COLD



AIR OUT OF DASH VENTS

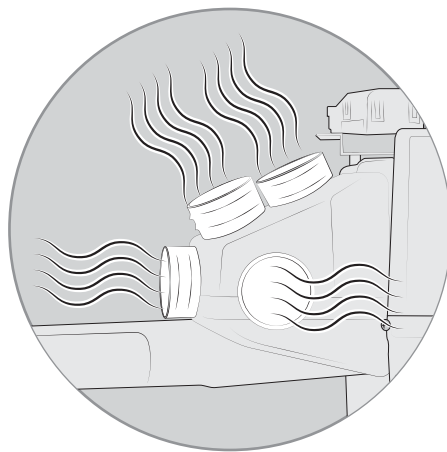

2

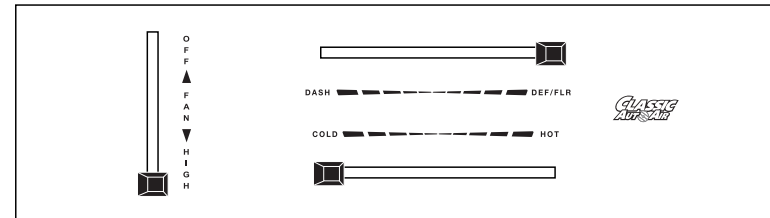

Move MODE knob to DEFROST/FLOOR



AIR OUT OF DEFROST/FLOOR VENTS

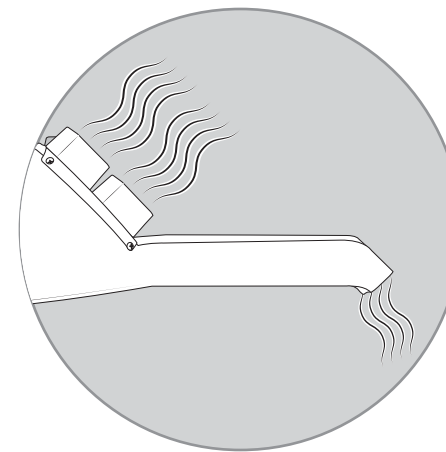

BENCH CALIBRATION & FUNCTION TESTING

• Function Test, Steps 4 and 5

4

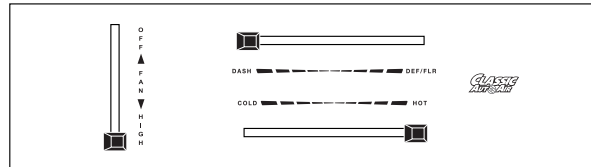

Move TEMP knob to HOT

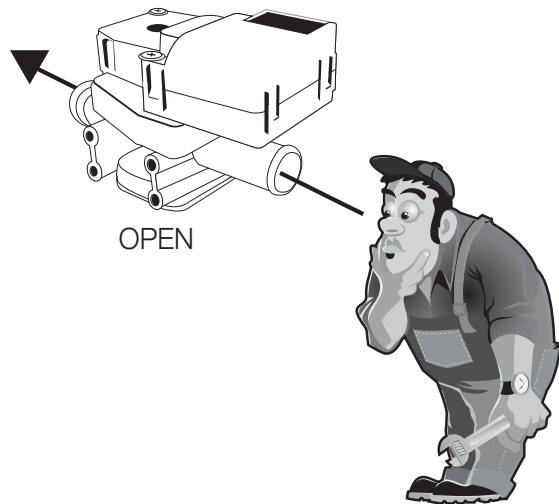

You will be able to see through water valve passage

5

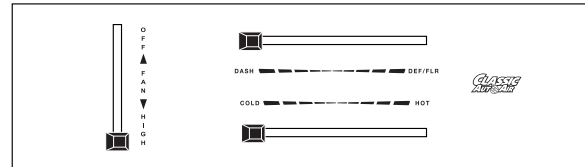

Move TEMP knob to COLD

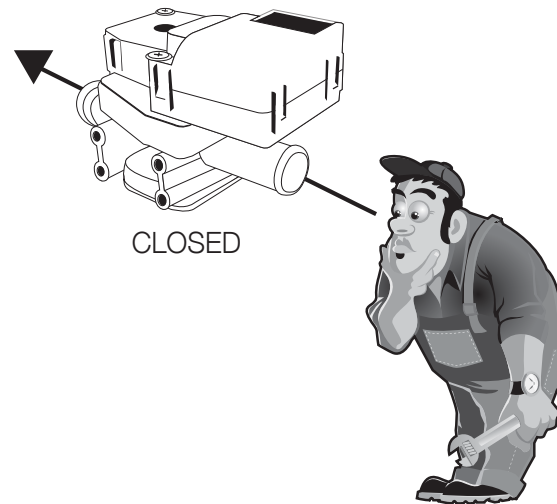

You will NOT be able to see through water valve passage

Return all wiring harnesses, water valve, and ECU to their originally bags/boxes (this keeps them organized for future installation steps).

Your controls are now fully calibrated to your unit. Please refer to the next steps in your installation manual for installing the system in your vehicle.

NOTE: IF DURING ANY OF THESE STEPS YOU DO NOT GET THE CORRECT OUTCOME, PLEASE CALL TECH SUPPORT BEFORE INSTALLING INTO VEHICLE. 1(866)435-7801

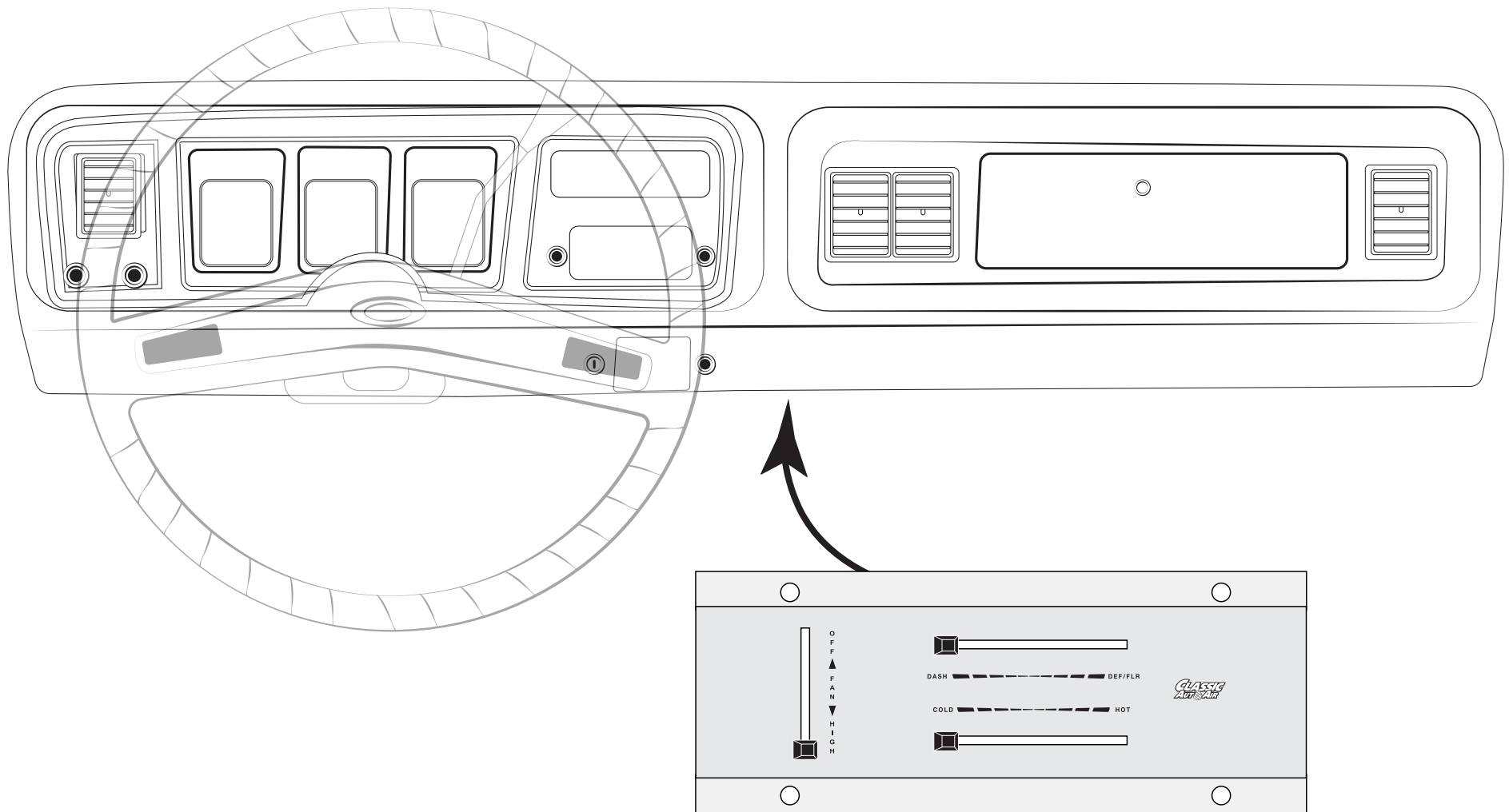

Install D.E.R. at this time using original mounting hardware.

NOTE: Two people are needed for this step!

Place evaporator on floor panel. Roll unit up behind the glove box opening, inserting tubes thru the holes in the firewall block off plate.

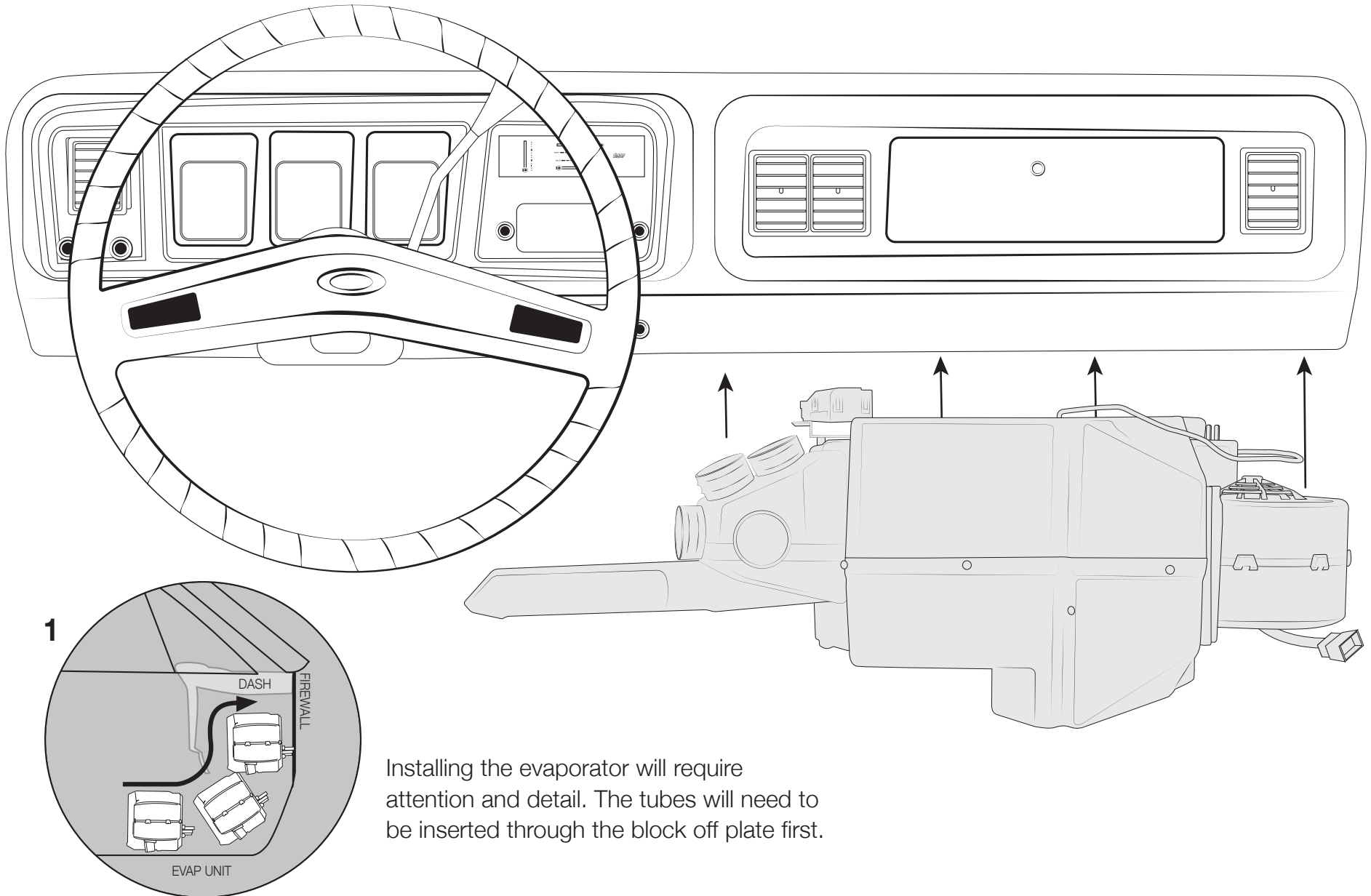

At this point you will need help mounting the evaporator. While one person inside the cab holds the evaporator in position the other person in the engine bay will attach the Evaporator Main Support Bracket to the Firewall Block Off Plate using (2) 1/4-20 x 5/8" Hex Head Bolts. Once the bolts are in you can attach (1) 1/4-20 x 5/8" Hex Head Bolt and (1) Flange Nut to the lower Firewall Support Bracket.

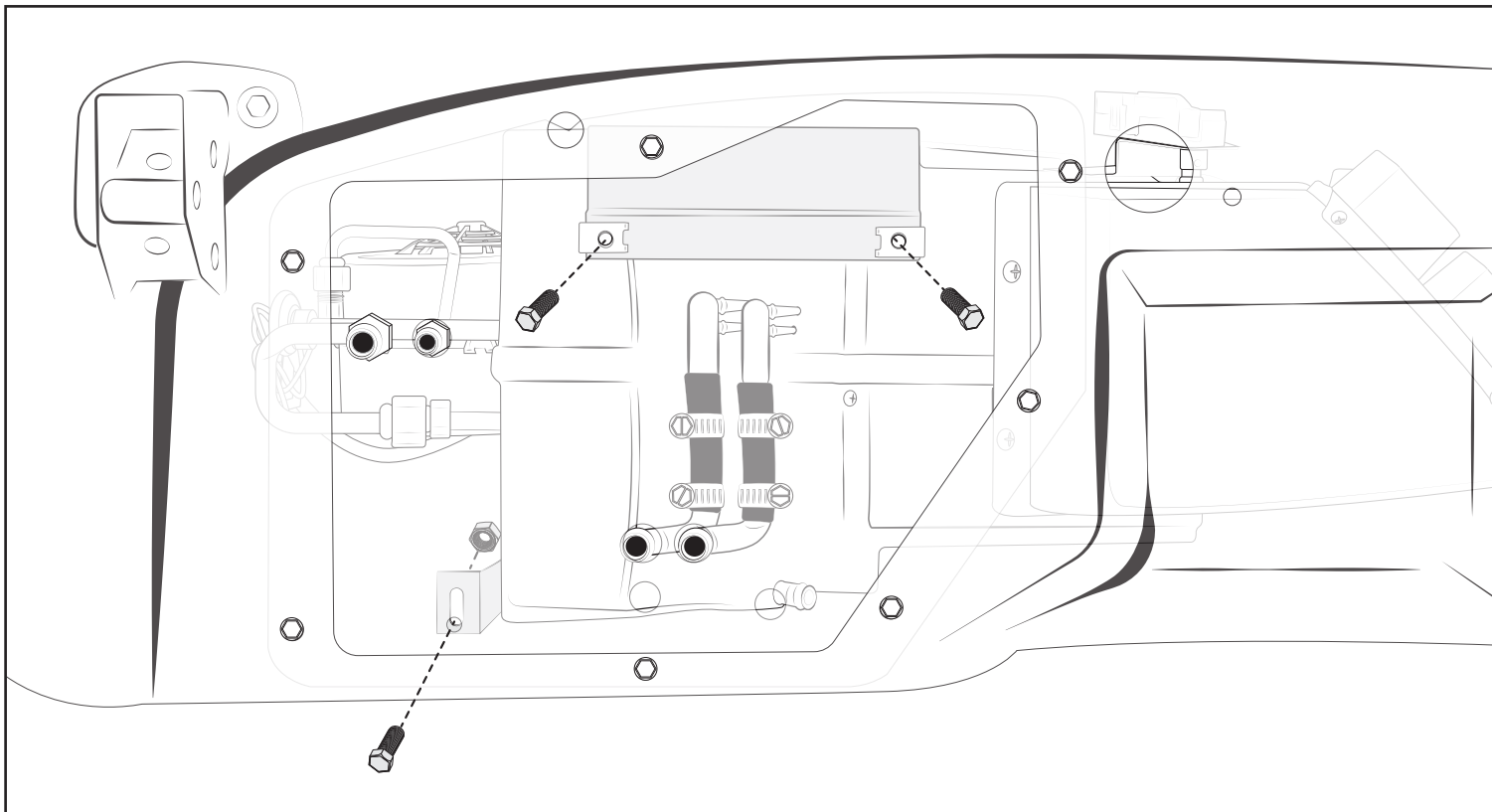



THESE ARE THE PARTS YOU WILL FIND IN BAG KIT C

You will use all of these parts and hardware during the next series of installation steps.

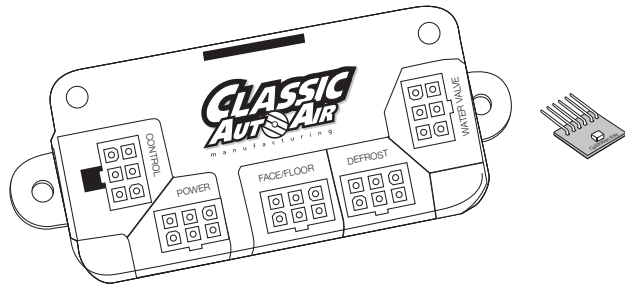

ECU and Calibration Key

DO NOT USE CALIBRATION KEY WITHOUT TECH SUPPORT

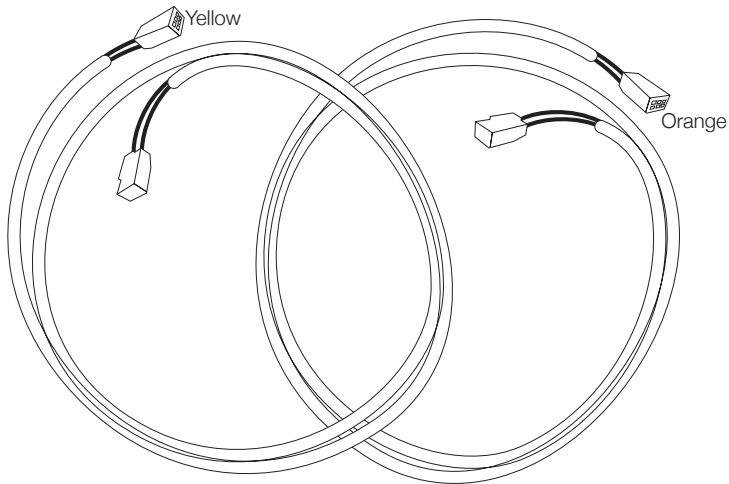
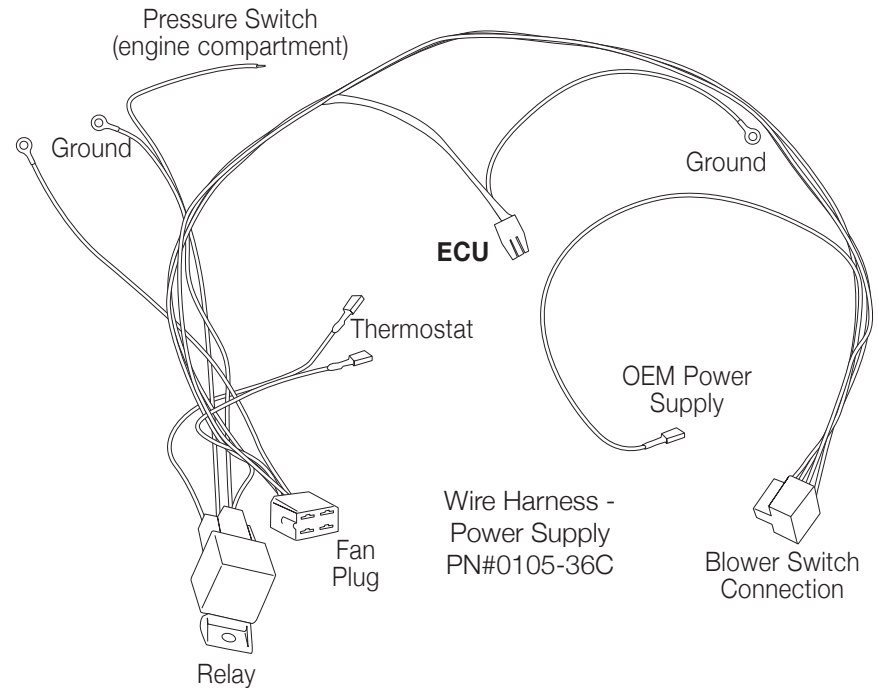

Wire Harness System



Male Spade Connector

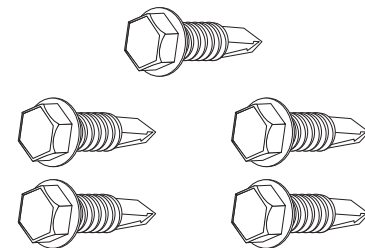

Five #10 - 16 x 3/4" Tek Screws

Illustrations NOT shown actual size

THESE ARE THE PARTS YOU WILL FIND IN BAG KIT D

You will use all of these parts and hardware during the next series of installation steps.

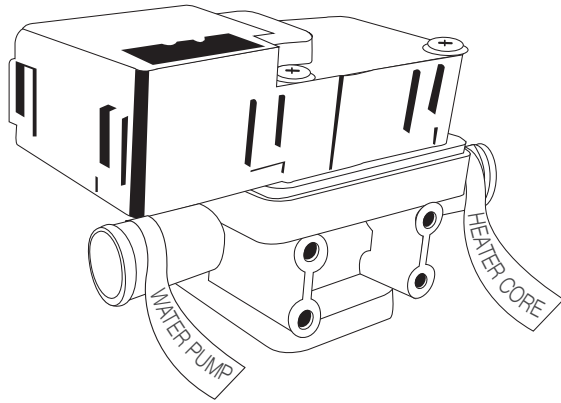

Electronic Water Control Valve
PN#16-1081-2

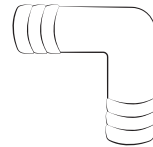

90 Degree Elbow



Clear Plastic Drain Tube

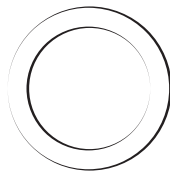

Cap Plug



Refrigerant Tape

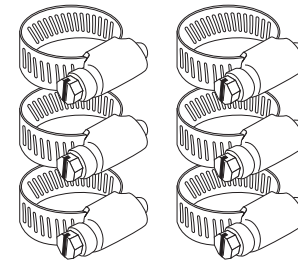

Six Worm Gear Clamps

Illustrations NOT shown actual size

Once the evaporator is fully mounted you can mount the Drain Tube in Bag Kit D. Cut the Drain Tube to a desired length to feed through the firewall plate using the 90 Degree Elbow provided.

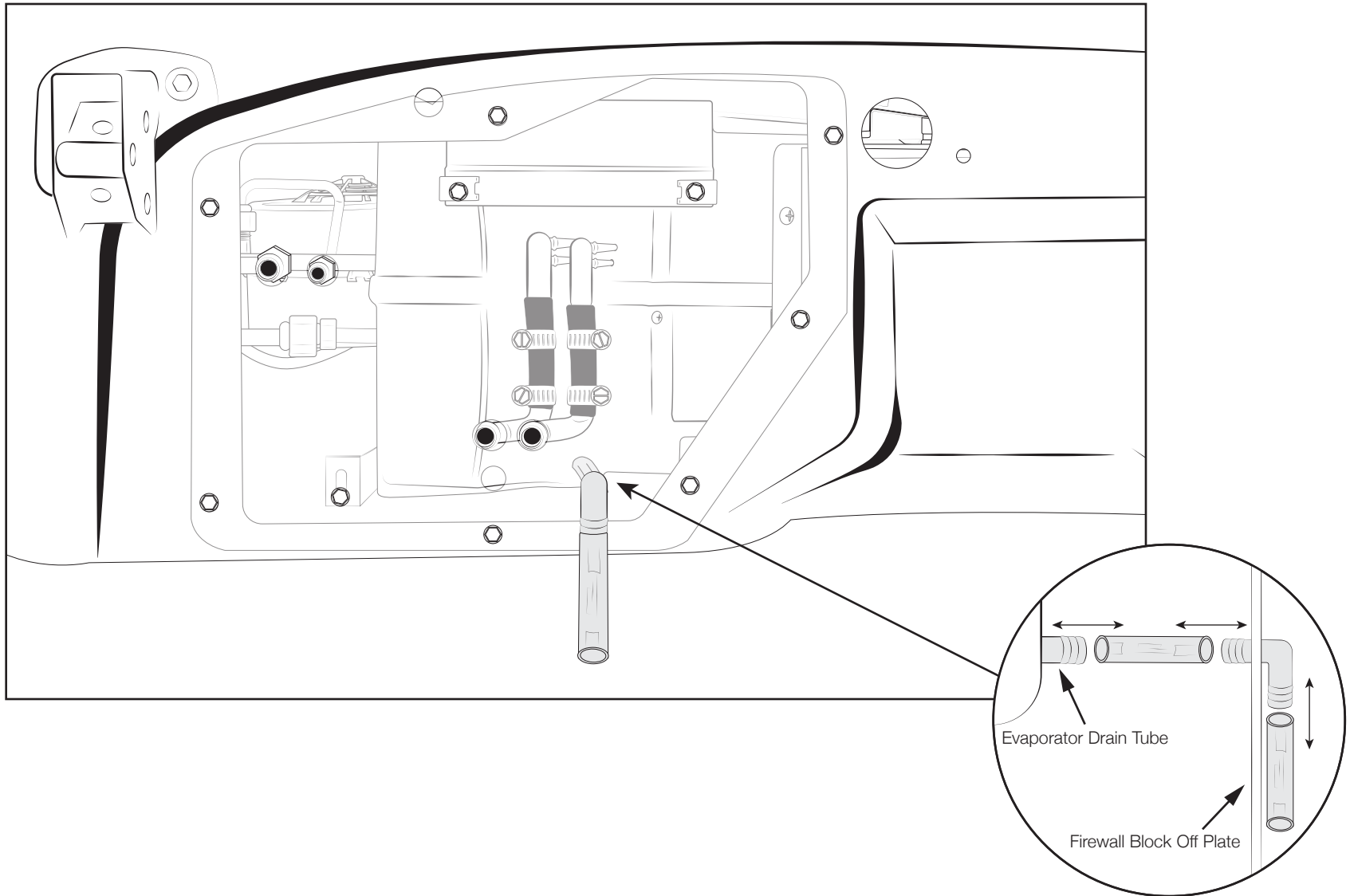

IMPORTANT NOTICE: PROPER INSTALLATION OF WATER VALVE

Your water valve MUST be installed per these instructions!... (If not, your system will not work properly.)

The **Right** heater tube connection on firewall will be routed to the water connection on intake manifold using 5/8" dia. heater hose with the supplied worm gear clamp.

The **Left** heater tube connection on the firewall will be routed to the water valve connection labeled **heater core**, using a 6" piece of 5/8" heater hose attached with supplied worm gear clamp.

Connect the remaining outlet on water valve labeled **water pump** to the water pump using 5/8" dia. heater hose with the supplied worm gear clamp.

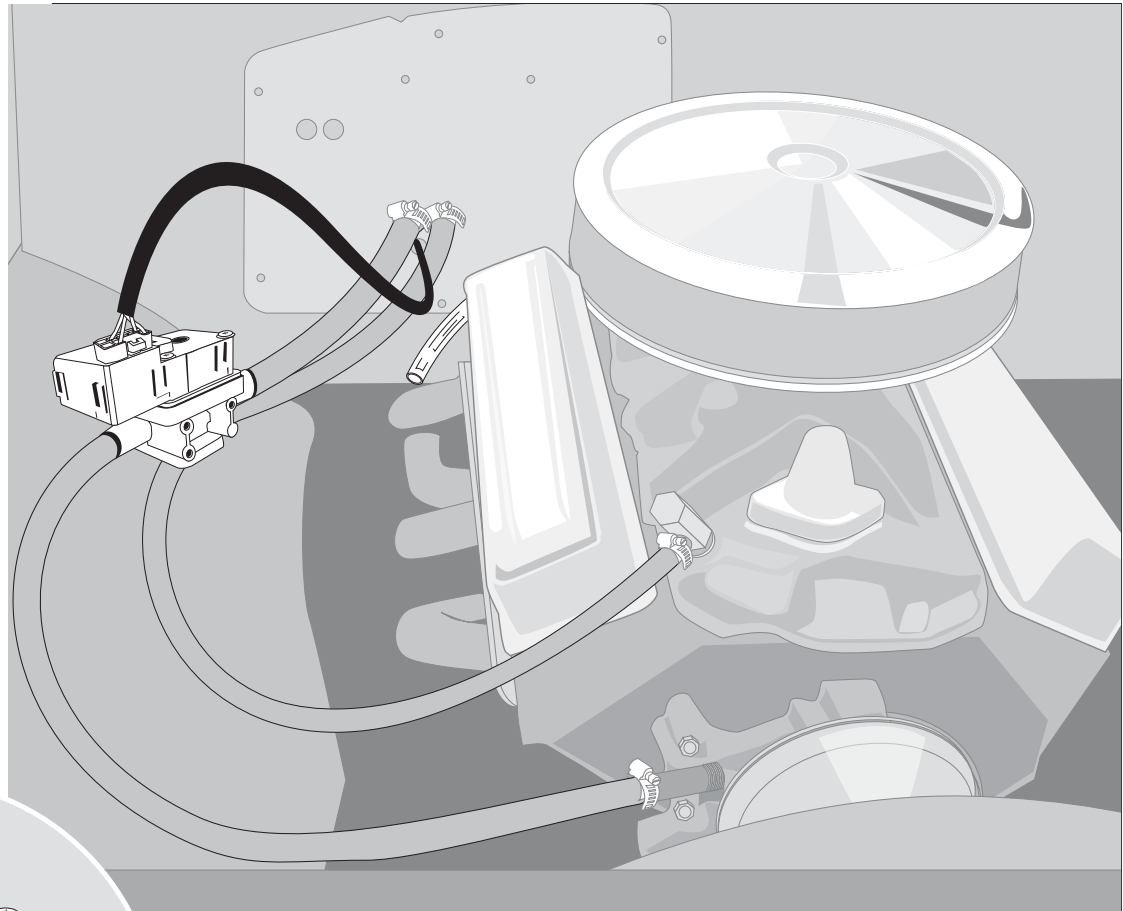

**FOLLOW THESE
TAGS... CHECK IT
TWICE BEFORE
PROCEEDING!**

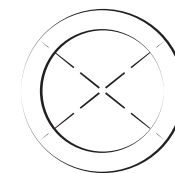
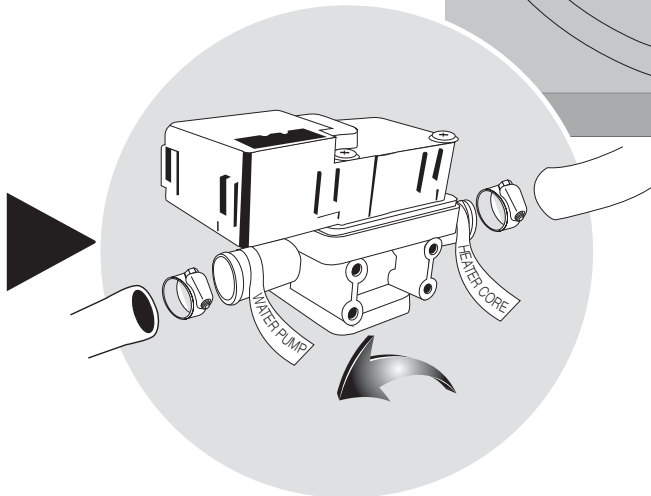

Make an X slit (cut) in the 3/4" cap plug, then feed harness through.

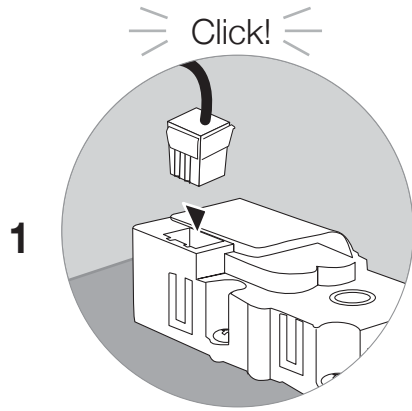

Connect Yellow Harness into Face/Floor Servo Motor

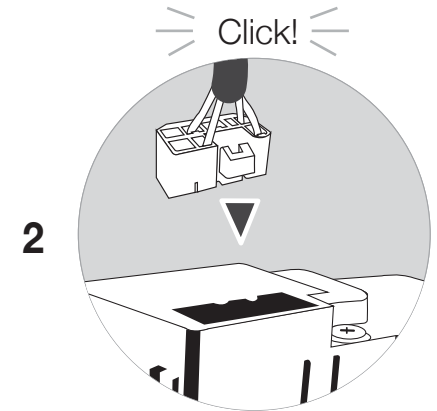

Connect Orange Harness into water valve

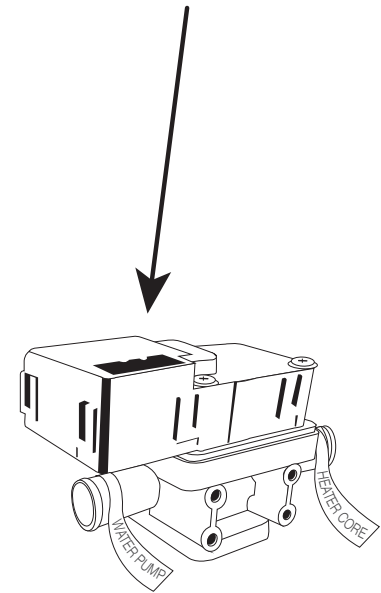
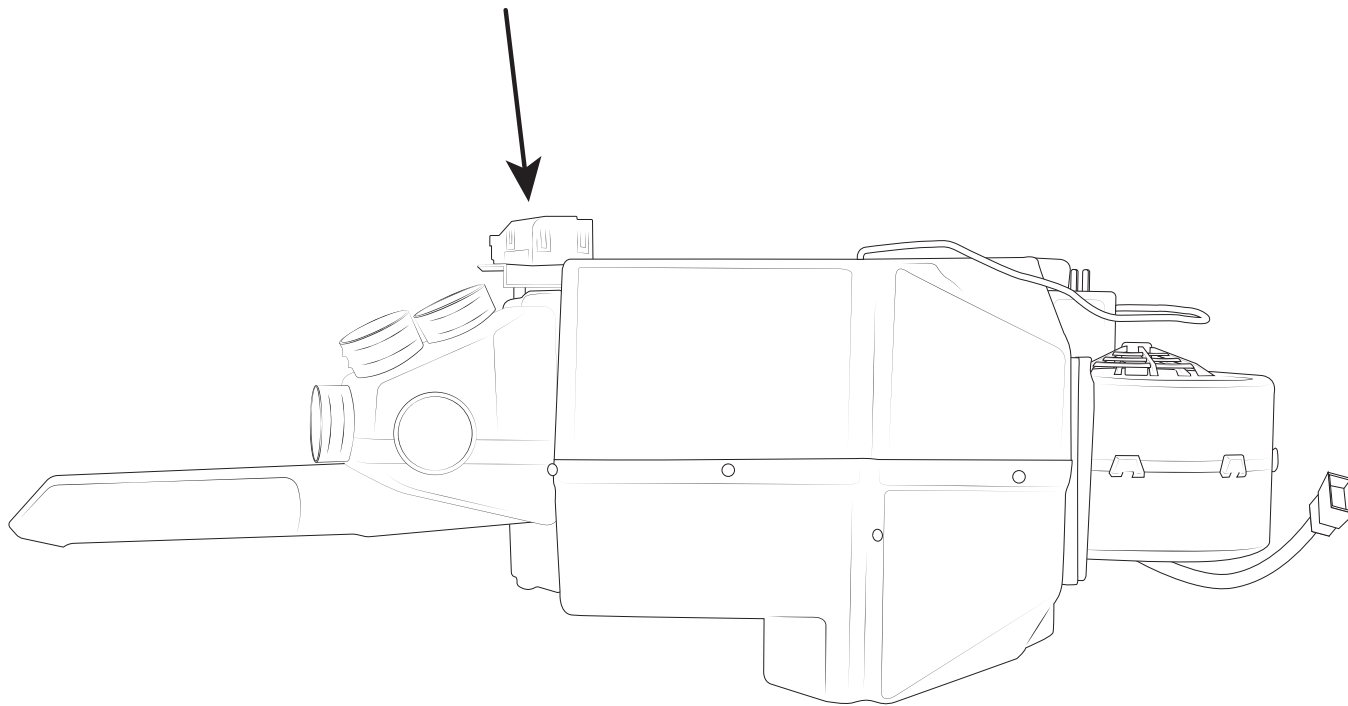

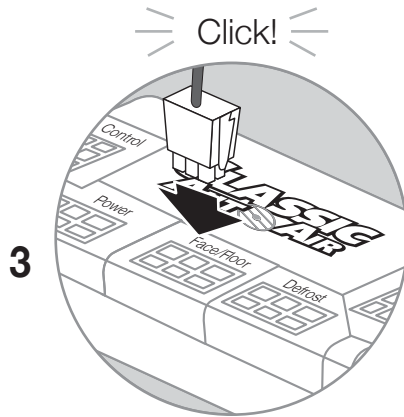

Plug Yellow Harness into Face/Floor Port on ECU

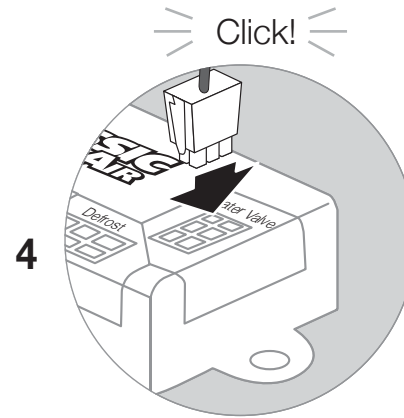

Plug Orange Harness into Water Valve Port on ECU

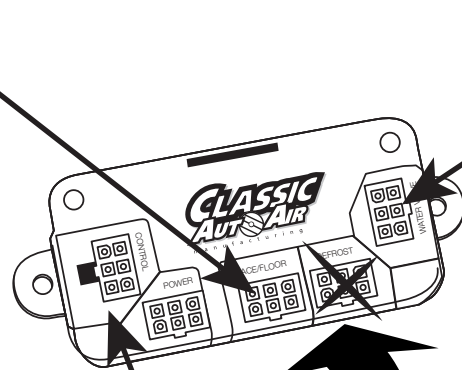

From your controls connect Green Harness into Control Port on ECU

5

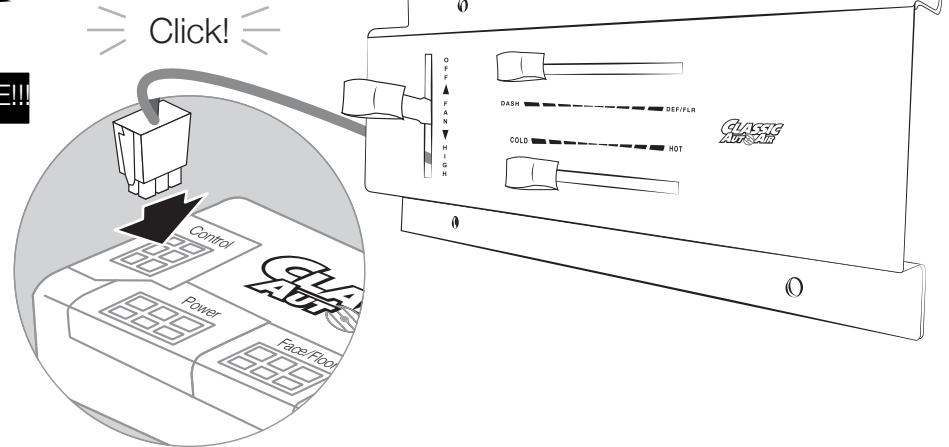

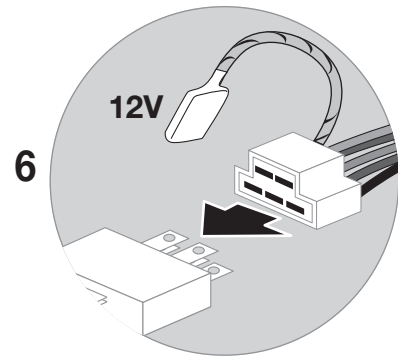

6
Connect corresponding fan switch harness to the blower switch on controls connect power lead to 12V.

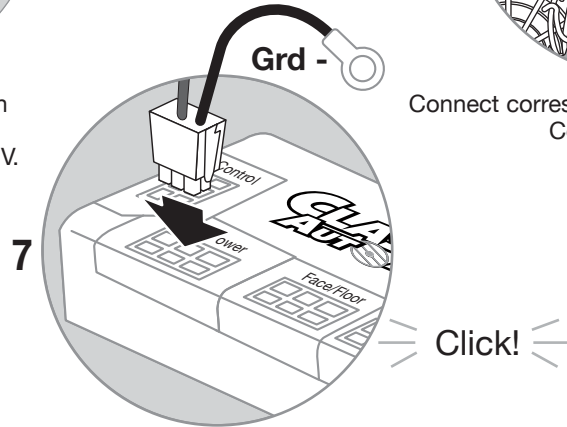

7
Connect red tagged power harness to POWER port on ECU. Connect ground.

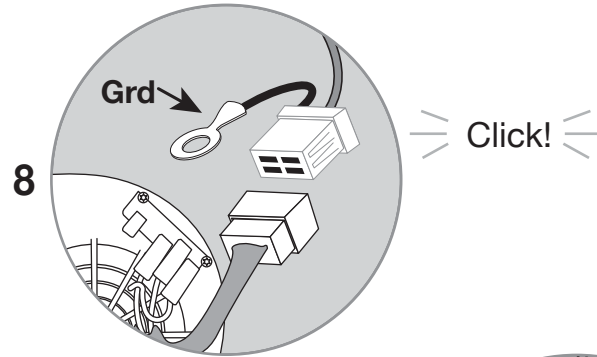

8
Connect corresponding fan motor harness. Connect ground.

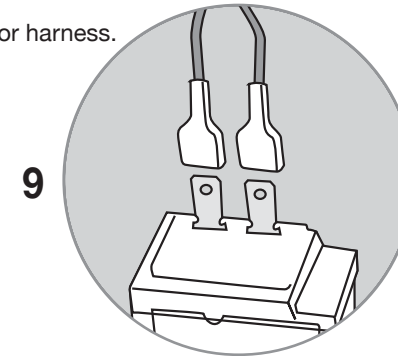

9
Connect both BLUE leads into thermostat (either lead into either terminal)

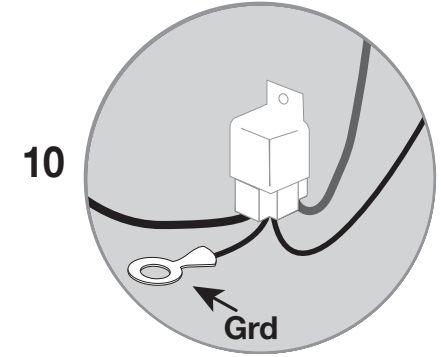

10
Connect ground.

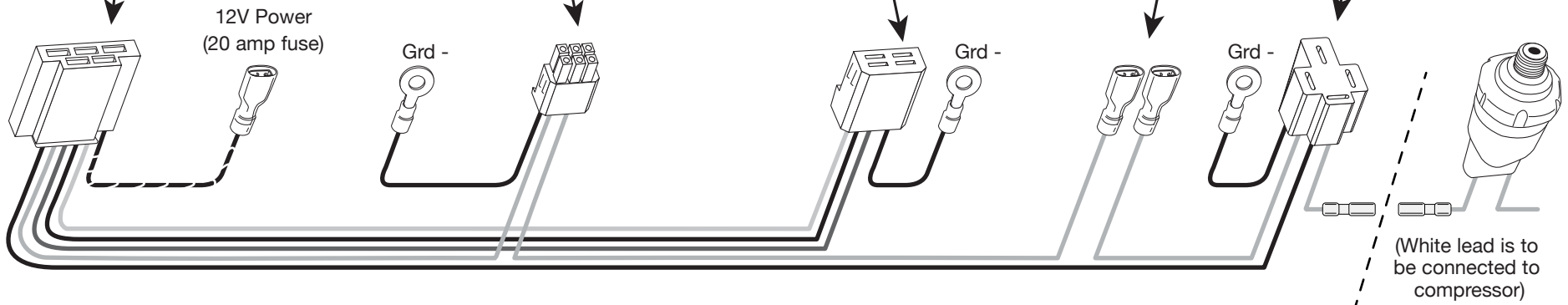

(White lead is to be connected to compressor)

THESE ARE THE PARTS YOU WILL FIND IN BAG KITS E, F, and G

You will use all of these parts and hardware during the next series of installation steps.

Bag E

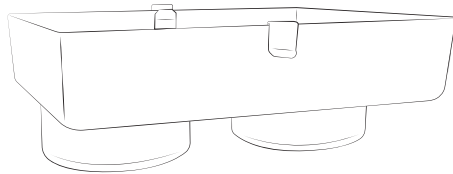

Defrost Adapter
PN# 2-2095FA-1

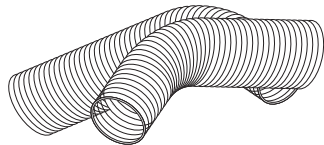

Two Duct Hoses, 2" I.D.

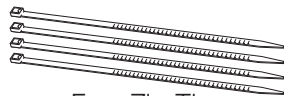

Four Zip-Ties

Bag F

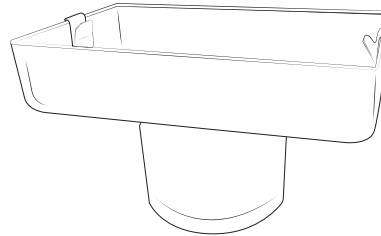

Passenger Dash, Adapter
PN# 2-2093-3

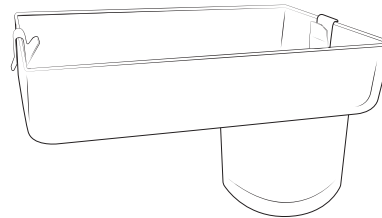

Driver Dash, Adapter
PN# 2-1057-2

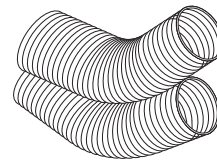

Two Duct Hoses, 2" I.D.

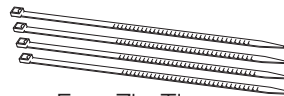

Four Zip-Ties

Bag G

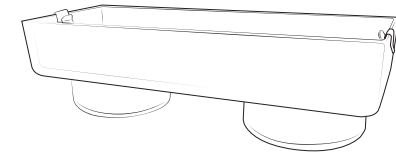

Hose, Adapter, Center
PN# 2-2095FA-2

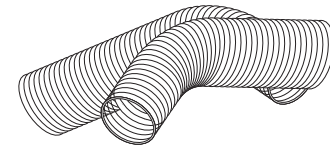

Two Duct Hoses, 2" I.D.



Two Zip-Ties

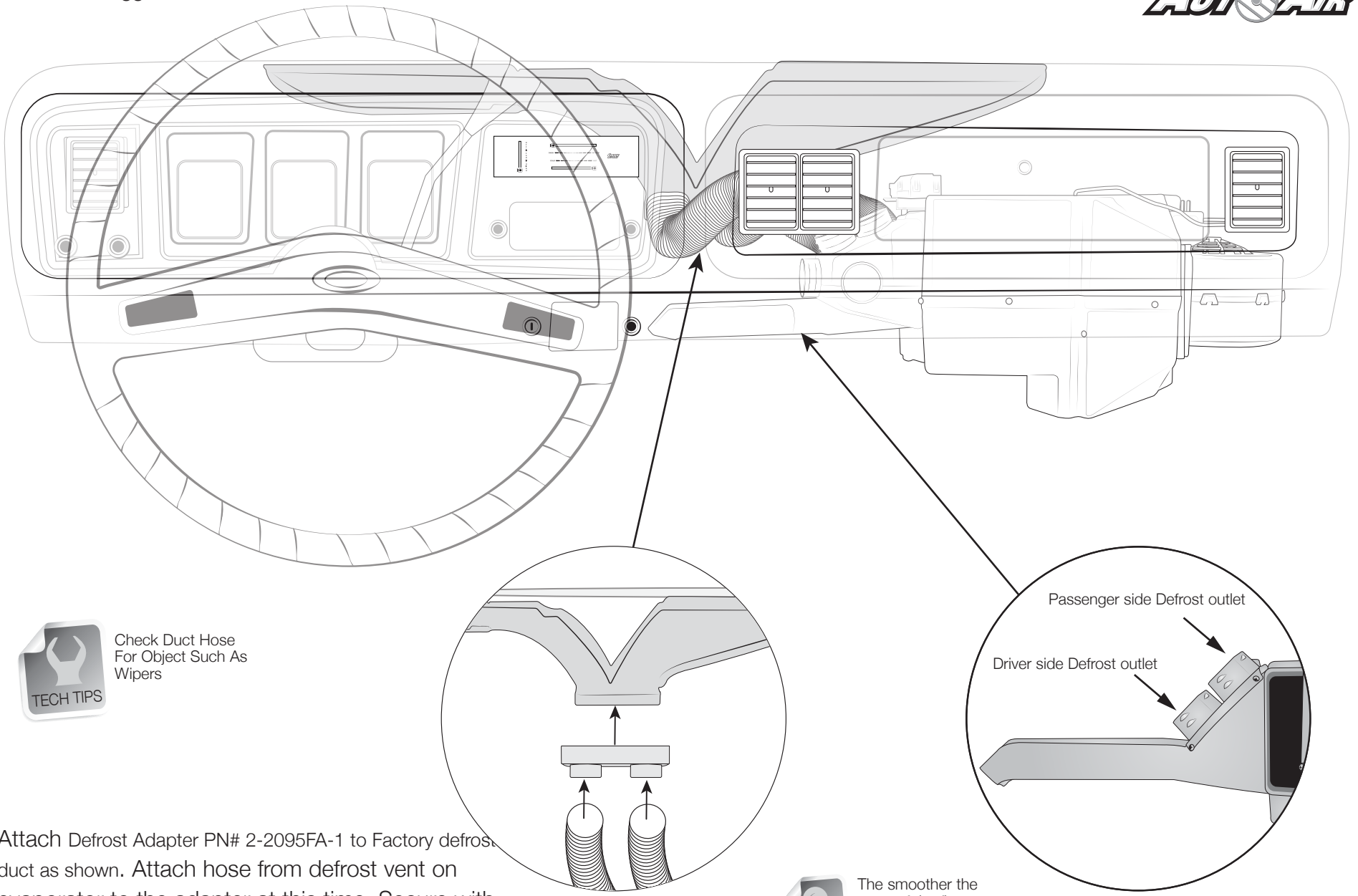

Check Duct Hose For Object Such As Wipers

Attach Defrost Adapter PN# 2-2095FA-1 to Factory defrost duct as shown. Attach hose from defrost vent on evaporator to the adapter at this time. Secure with Zip-tie.

Note keep the flex hose free and open for air flow.



The smoother the route of the flex hoses the better the airflow.

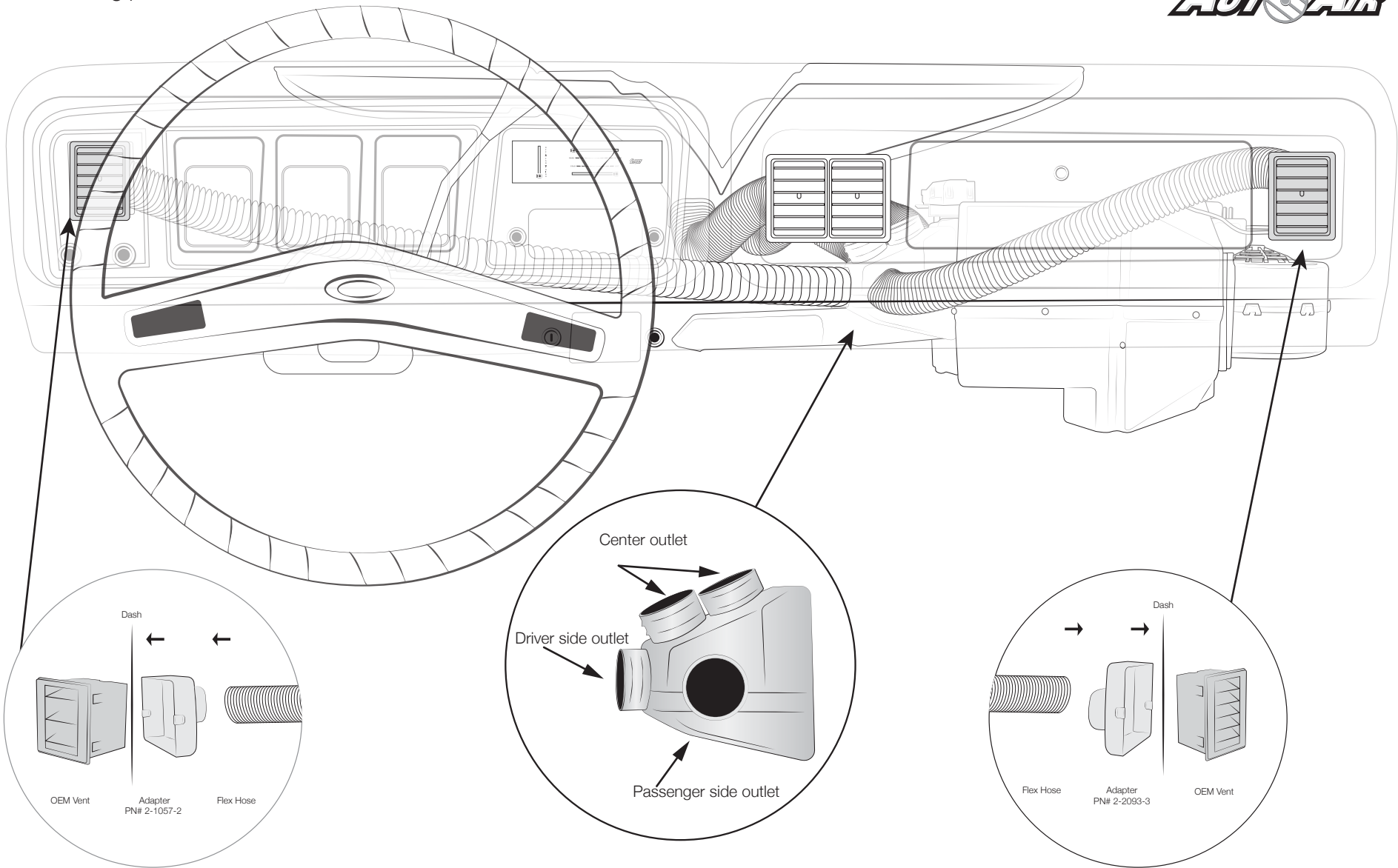

Attach Adapter PN# 2-1057-2 to the back of OEM Vent housing. Attach Flex hose to the back of Adapter PN# 2-1057-2 secure with Zip-Tie.



The smoother the route of the flex hoses the better the airflow.

Attach Adapter PN# 2-2093-3 to the back of OEM Vent housing. Attach Flex hose to the back of Adapter PN# 2-2093-3 secure with Zip-Tie.

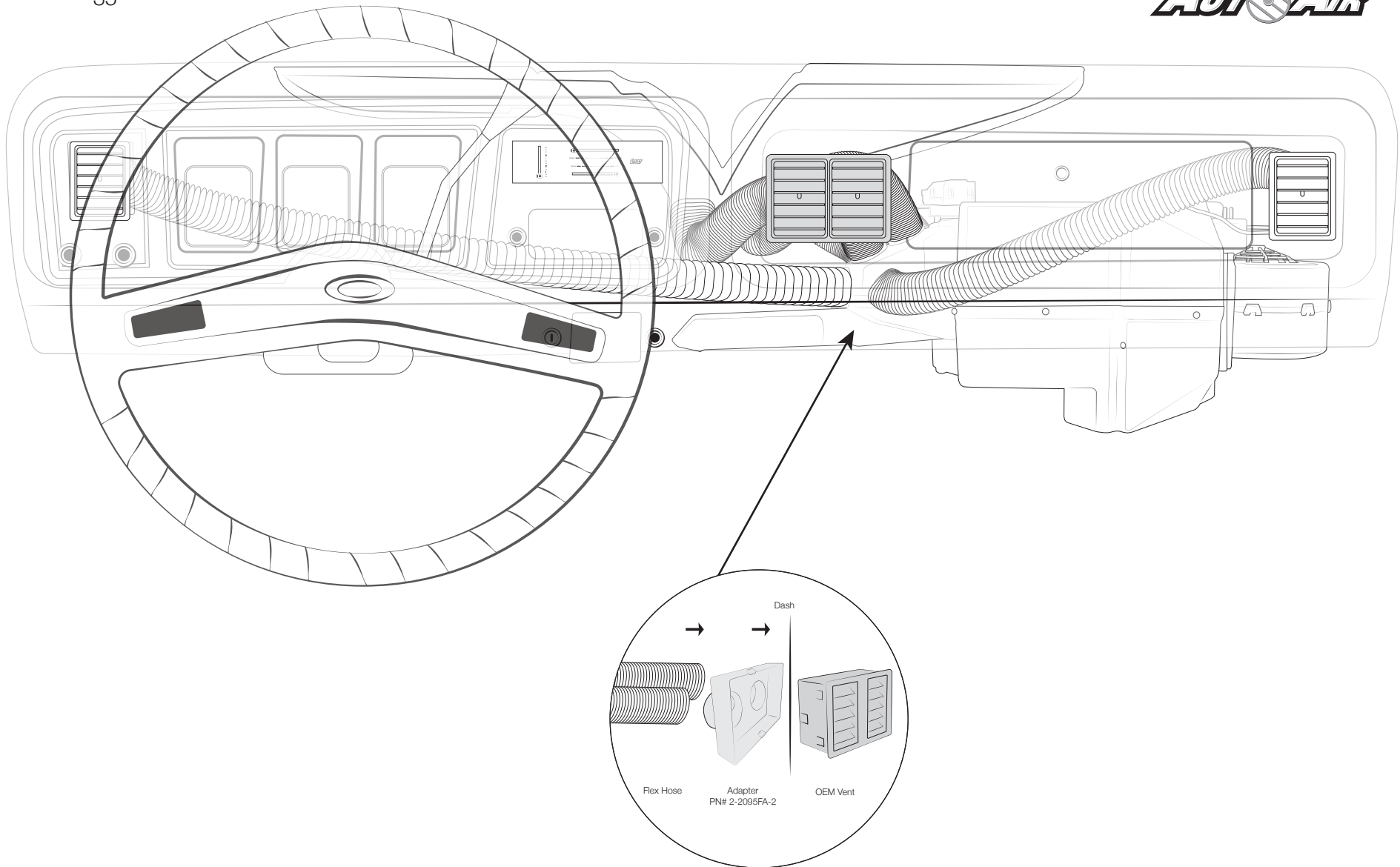

Attach Adapter PN# 2-2095FA-2 to the back of OEM Vent housing. Attach Flex hose to the back of Adapter PN# 2-2095FA-2 secure with Zip-Ties.



Check Duct Hose For Object Such As Wipers



The smoother the route of the flex hoses the better the airflow.

THESE ARE THE PARTS YOU WILL NEED FOR THE ENGINE COMPARTMENT INSTALLATION

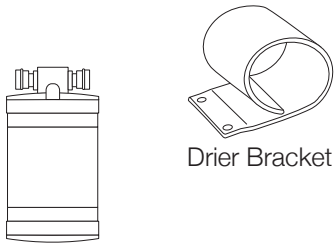

Drier Bracket

Drier

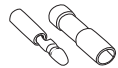

Splice and Bullet Connector



Six #10 x 1/4" Screws

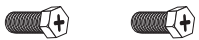

Two #8-32 x 1/2" Bolts



Two #8-32 Nylock Nuts

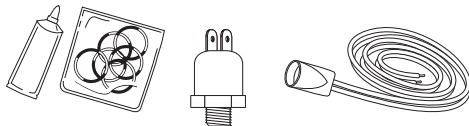

Pressure Switch and harness,
Bag of O-rings and Mineral Oil Tube

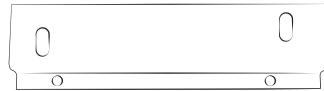

Condenser
Bracket
PN#0122-54



Condenser
Bracket
PN#0019-52

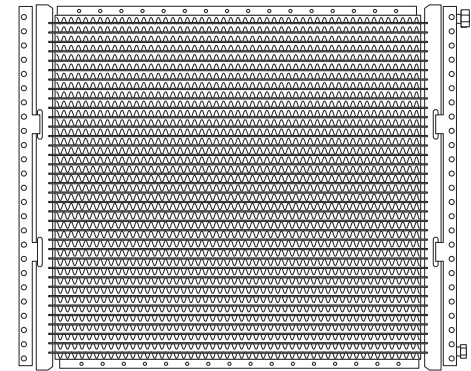

Condenser
PN# 11-1093

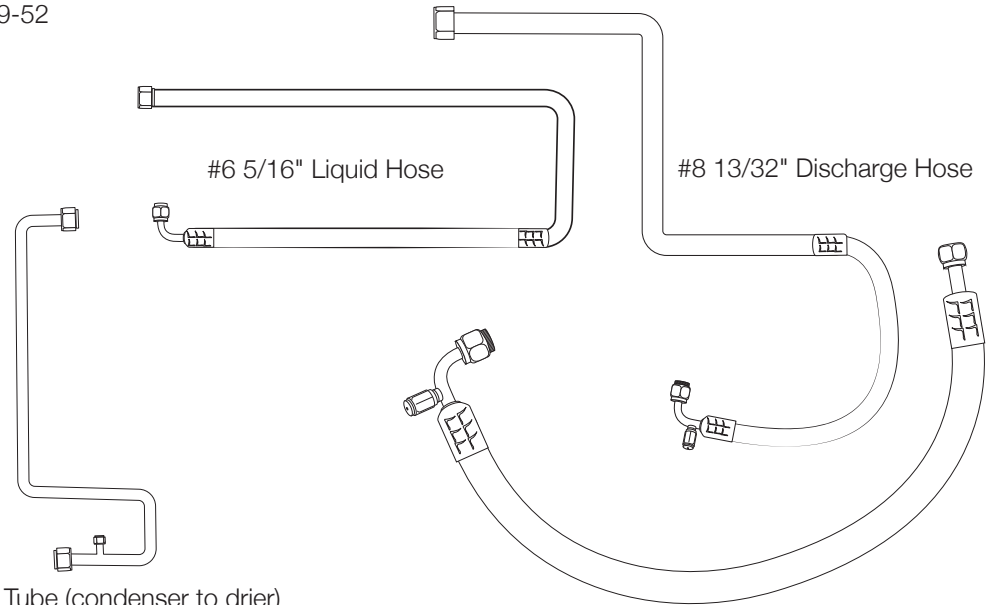

#6 5/16" Liquid Hose

#8 13/32" Discharge Hose

Liquid Tube (condenser to drier)
PN#0019-93

#10 1/2" Suction Hose

At this time you will want to disconnect the battery and drain radiator. Remove the hood latch and retain the hardware for re-installation.

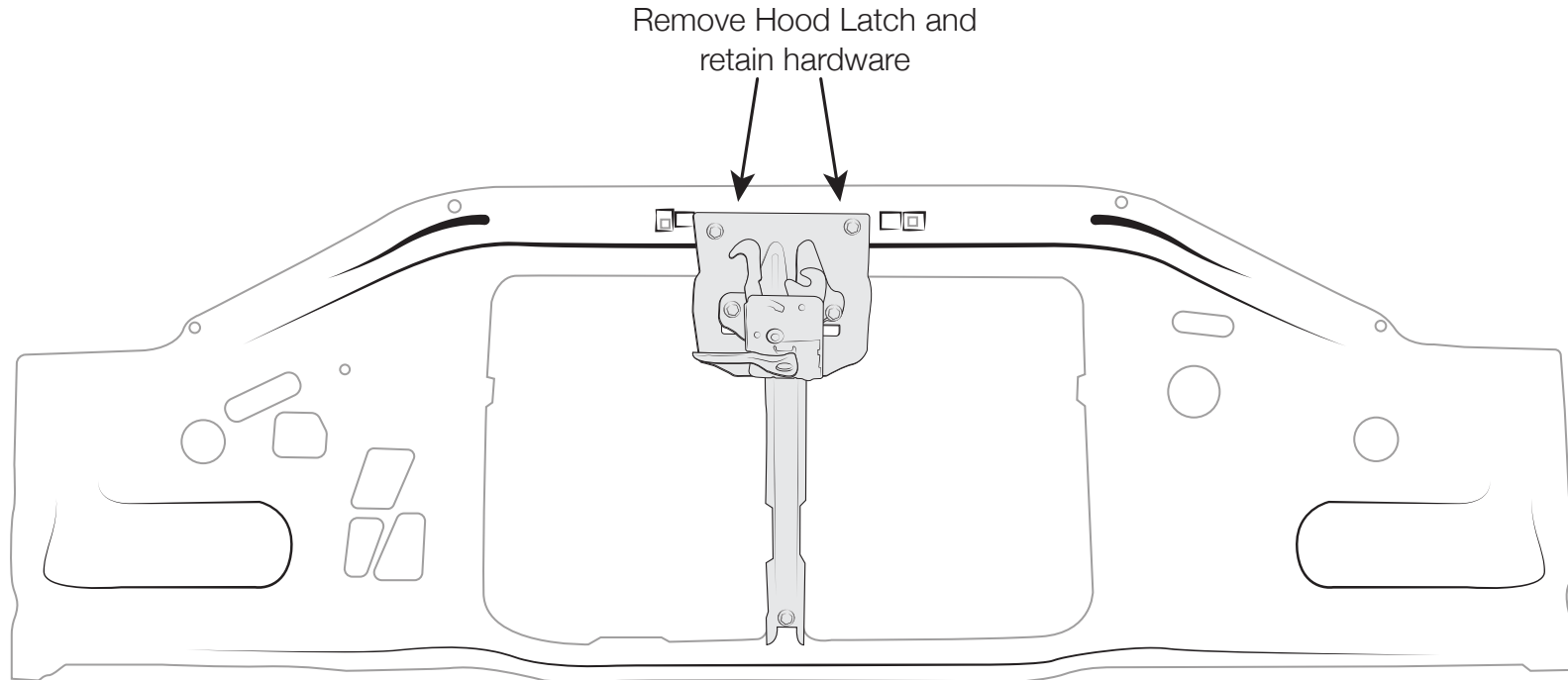



CONDENSER PREPARATION. You can perform most of the following steps on a clean flat surface like a workbench. Lay the condenser down so that both hose connections are on the **RIGHT SIDE** (the larger connection will be on top).

Locate condenser, Condenser Bracket PN#0122-54, Condenser Bracket PN#0019-52, and (4) #10 x 1/4" Screws. Attach brackets to the coil as shown.

Bracket angles outward

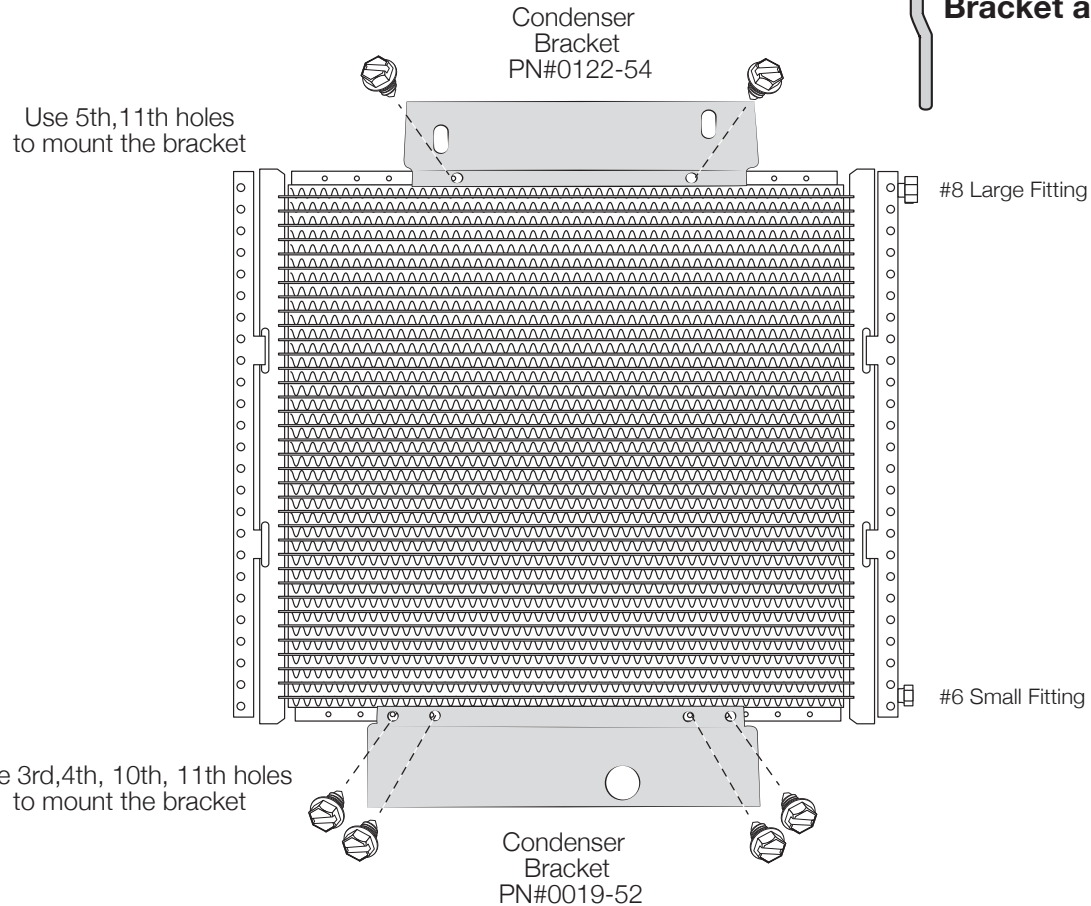

Install with bends toward you

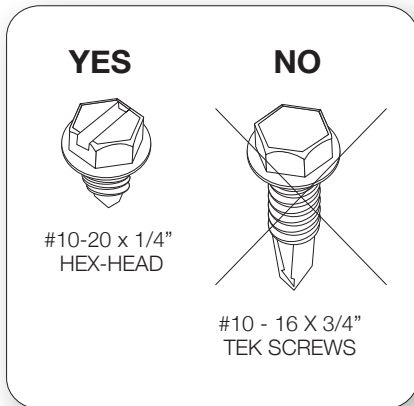

DRIER AND CONDENSER PREPARATION. Lay the condenser down so that both hose connections are on the **RIGHT SIDE** (the larger connection will be on top). The drier is conveniently mounted on the left hand side of the condenser.

First insert the drier into the drier mounting bracket. Attach the drier liquid tube to the drier and also to the connection on the condenser (tighten connections at either end using supplied o-rings on both ends and a few drops of mineral oil to each o-ring). With these two combined it will be easy to find the correct place to attach the drier bracket to the condenser with the included Two #8-32 x 1/2" Bolt screws and Two #8-32 Nylock Nuts (attach drier and bracket from the front of the condenser).

PRESSURE SWITCH: Screw the high-pressure switch into the port on the liquid tube. Go ahead and plug the pressure switch harness into the switch at this time (black electrical boot with two long white wires).

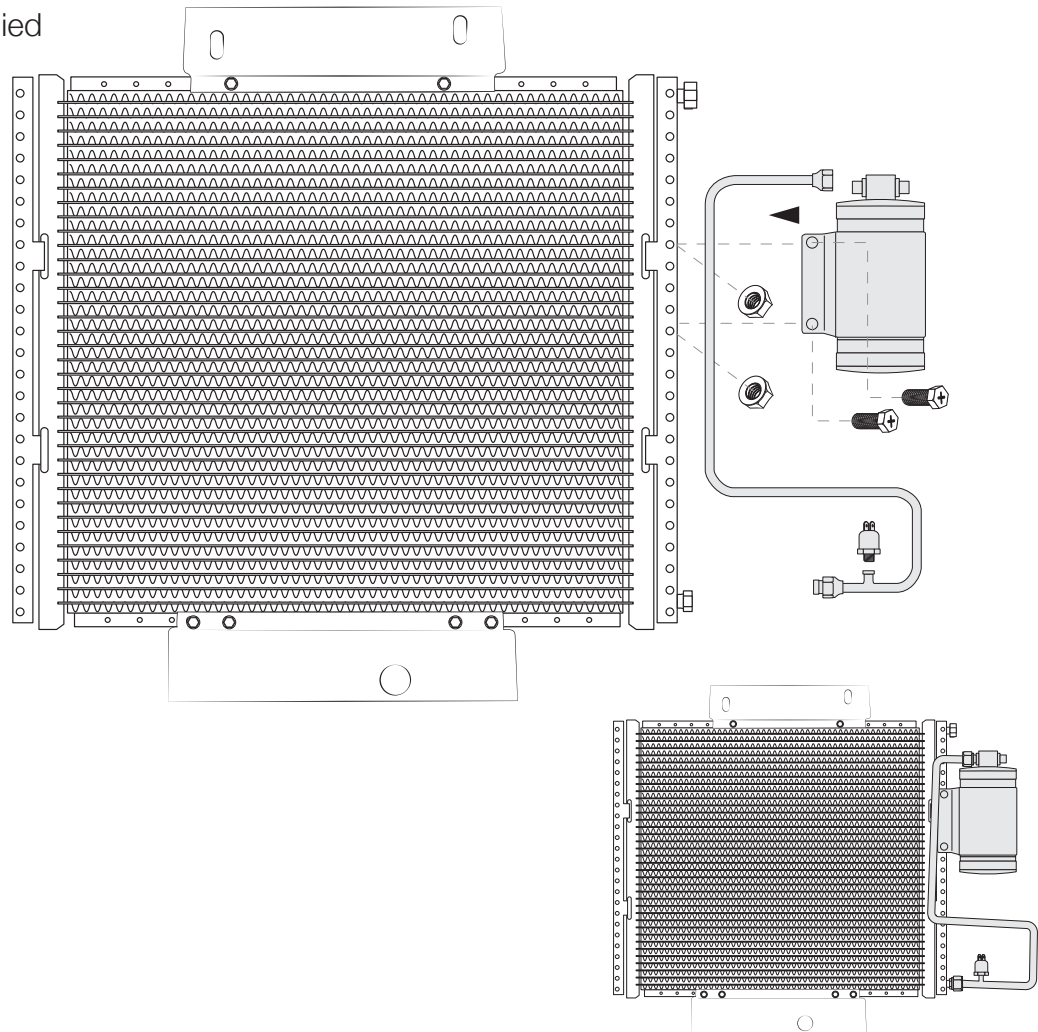

YES

#10-20 x 1/4"
HEX-HEAD

NO

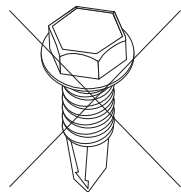
#10 - 16 X 3/4"
TEK SCREWS

MOUNTING CONDENSER. Using the original hardware mount condenser and hood latch at this time. Condenser and hood latch mounting point will line up exactly for easy installation.

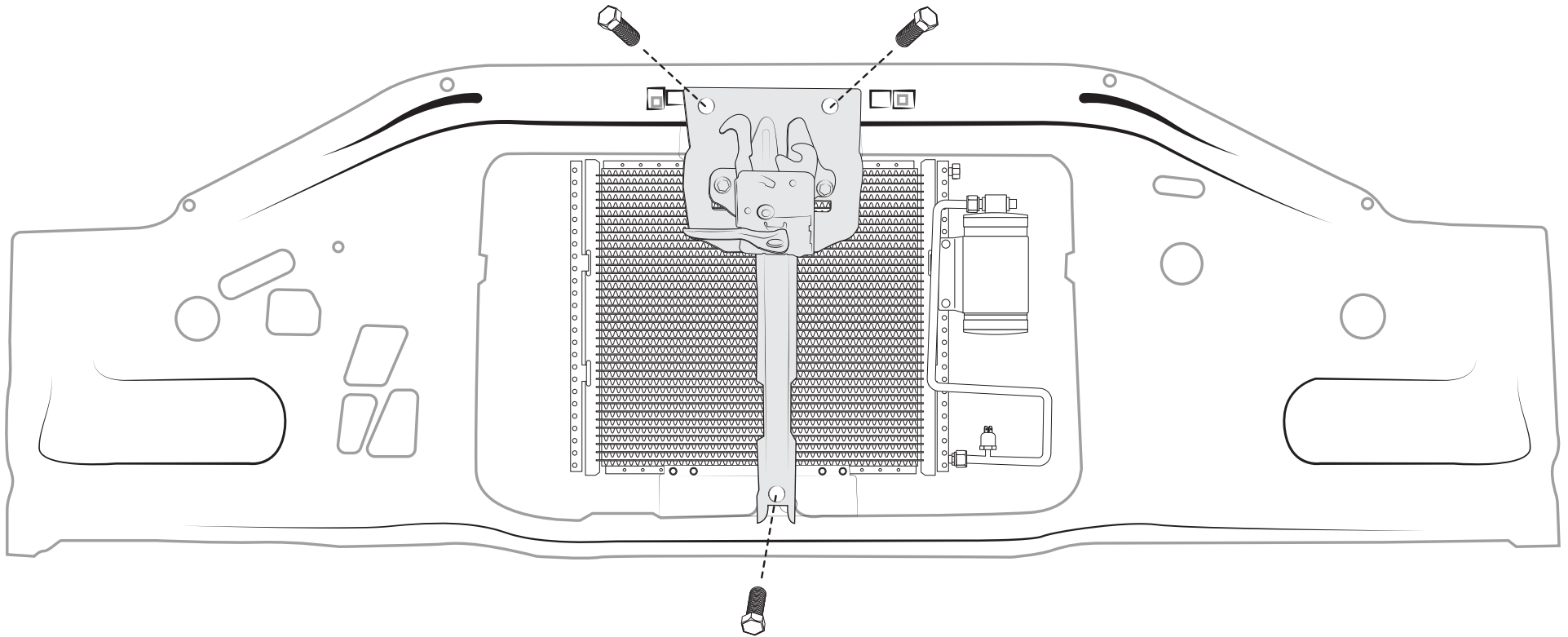

MOUNTING TUBES. At this time you can attach the #6 to the Drier and route through the core support as shown. Mount the #8 tube to the TOP port of the condenser and route through the core support as shown.

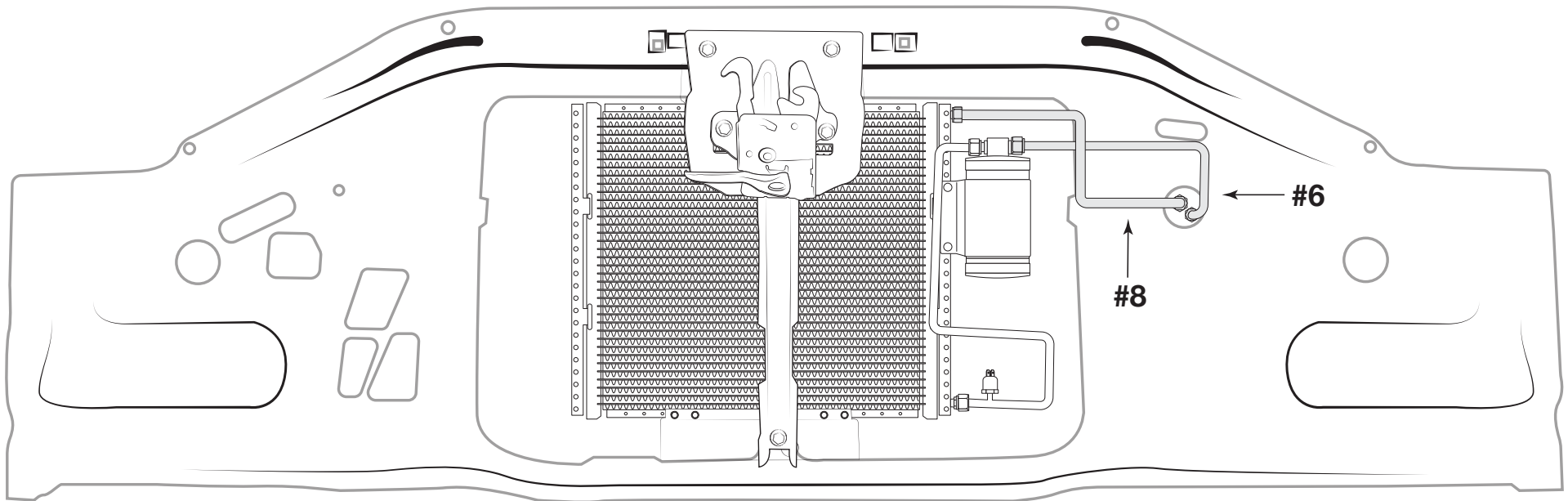

Connecting the Hoses



Install the compressor kit. Included was a premium compressor kit with all the parts you'll need to install the compressor. This kit includes instructions specifically written for your engine. Once you've installed the complete compressor kit, continue on to connecting the hoses.

CONNECTING THE HOSES:

Based on PASSENGER or DRIVERS SIDE compressor mounting see illustrations for routing.

The #10 (**LARGEST**) refrigerant hose. Attach end with service fitting to the compressor using (1) #10 o-ring and a few drops of mineral oil. Attach other end to #10 fitting at the firewall. Attach using one #10 o-ring and a few drops of mineral oil. Tighten securely.

The #6 (**SMALLEST**) refrigerant hose. Route behind fender and to the connection on firewall. Attach using two #6 o-ring and a few drops of mineral oil.

The #8 (**MEDIUM**) refrigerant Hose. Route across engine and to the connection on compressor. Attach using two #8 o-ring and a few drops of mineral oil.

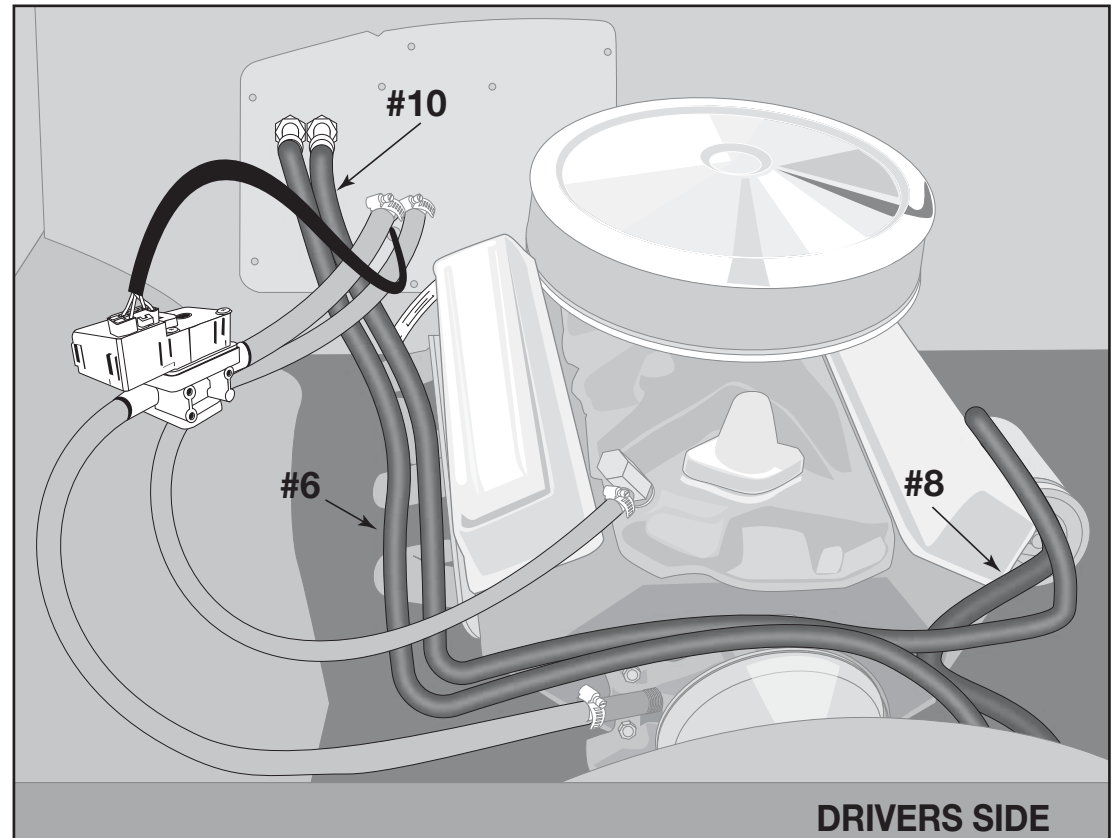

TWO WRENCH METHOD

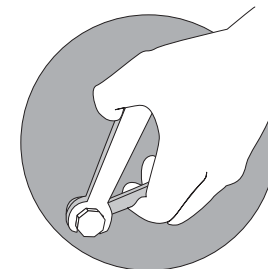

Reminder...
Use two
wrenches to
tighten o-ring
fittings

New A/C System Preparation... A MUST READ!

Please read through these procedures before completing this new A/C system charging operation.

A licensed A/C technician should be utilized for these procedures to ensure that your new system will perform at it's peak, and that your compressor will not be damaged.

1. Your radiator/cooling system is an integral part of your new system. Please insure that you have a 50/50 mix of distilled water and antifreeze. The heater coil **MUST** be purged (cycle heater control valve) to make sure no water, without antifreeze, is in the heater coil before you charge the A/C system.
2. Evacuate the system for a minimum of 45 minutes.
3. Your new compressor **MUST** be hand turned 15-20 revolutions before and after charging with liquid. Failure to do this may cause the reed valves to become damaged. This damage is **NOT** covered by your warranty.
4. Your new system requires 1.5lbs (24oz) of R134a refrigerant.
5. Your new compressor comes charged with oil - **NO** additional oil is necessary.
6. Ensure that the new belt is tight.
7. **DO NOT** charge system with liquid refrigerant!

Recommended Test Conditions:

(After system has been fully charged and tested for basic operation)

- Determine the temperature outside of the car
- Connect gauges or service equipment to high/low charging ports
- Place blower fan switch on medium
- Close all doors and windows on vehicle
- Place shop fan directly in front of condenser
- Run engine idle up to approximately 1500 rpm

ACCEPTABLE OPERATING PRESSURE RANGES:

1. High-side pressures: 150-275 PSI
2. Low-side pressures: 10-25 PSI(in a steady state)

Readings above are based on an ambient temperature of 90° with an adequate airflow on condenser.

CAUTION! When mounting your compressor and/or adjusting the belt use caution. Mount by using the centerline of the oil fill plug as your guide. The compressor can **ONLY** be mounted in-between the 9 to 3 positions. DO NOT mount in-between the 4 to 8 positions.

This can cause compressor failure.

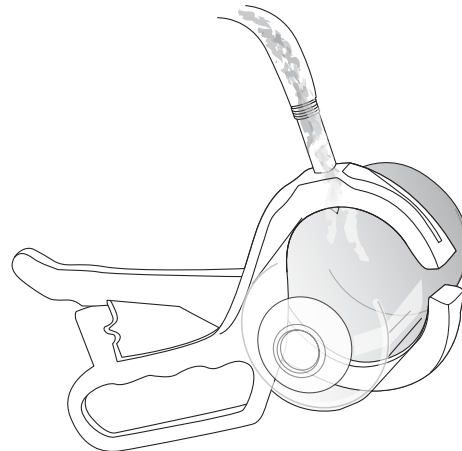

CENTERLINE OF THE OIL FILL BOLT

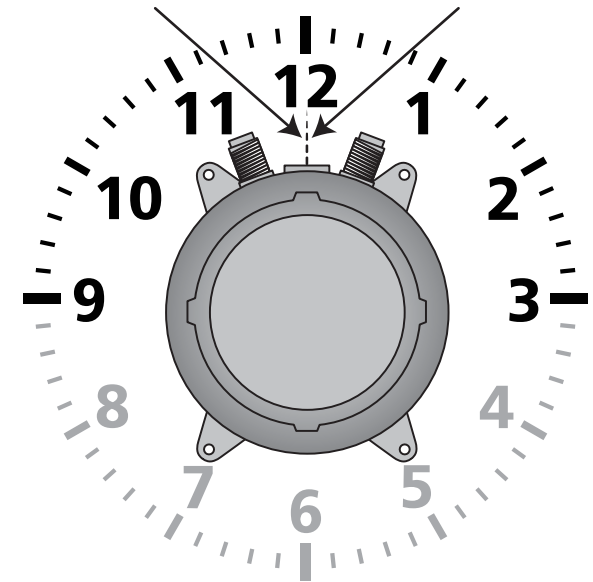

Do NOT tilt, shake or turn refrigerant can upside-down OR use a charging station to install refrigerant while the engine is running. Doing so will direct liquid refrigerant into the compressor piston chamber, causing damage to reed valves and/or pistons and/or other components, as well as potentially seizing the compressor. Allow a minimum of 30 minutes for liquid to "boil off." You must hand turn the compressor hub (not the pulley) a minimum of 15 complete revolutions prior to starting the engine with the clutch engaged.

Troubleshooting Guide

Test conditions used to determine system operation:

These test conditions will simulate the effect of driving the vehicle and give the technician the three critical readings that they will need to diagnose any potential problems.

- A. Connect gauges or service equipment to high/low charging ports
- B. Place blower fan switch on medium
- C. Close all doors and windows on vehicle
- D. Place shop fan in front of condenser
- E. Run engine idle up to 1500 RPM

Acceptable operating pressure ranges (R134A type):

1. High-side pressures: 150-275 PSI
*note: general rule is two times the ambient/daytime temperature plus 15-20%
2. Low-side pressures: 10-25 PSI in steady state

Charge as follows: R134a = 1.5lbs (24oz)

No additional oil is necessary in our new compressors.

Typical problems encountered in charging systems - noisy compressor:

A noisy compressor is generally caused by charging a compressor with liquid or overcharging.

- A. If the system is overcharged both gauges will read abnormally high readings. This is causing a feedback pressure on the compressor causing it to rattle or shake from the increased cylinder head pressures. System must be evacuated and re-charged to exact weight specifications.
- B. Installing the heater control valve in the incorrect hose will cause the system to cool at idle and gradually warm up when the RPM's of the engine rise. The heater control is a directional valve; make sure the water flow is with the direction of the arrow. As the engine heats up, the water transfers the heat to the coil thus overpowering the a/c coil. A leaking or faulty valve will have a more pronounced affect on the unit's cooling ability. Installing the valve improperly - such as having the flow reversed - will also allow water to flow through which inhibits the cooling. Check for heat transfer by disconnecting hoses from the system completely. By running down the road with the hoses looped backed through the motor you eliminate the possibility of heat transfer to the unit.
- C. Evaporator freezing can occur both externally and internally on an evaporator core. External freeze up occurs when the coil can't effectively displace the condensation on the outside fins so the water forms ice. The evaporator core resembles a block of solid ice, it restricts the flow of air that can pass through it, which gives the illusion of the air not functioning. The most common cause of external freezing is the thermostat setting and humidity in the passenger compartment. All door and window seals should be checked in the event of constant freeze-up. A thermostat is provided with all units to control the cycling of the compressor.

D. Internal freeze-up occurs when the system has too much moisture inside. The symptoms of internal freeze-up often surface after extended highway driving. The volume of air stays constant but the temperature of the air gradually rises. When this freezing occurs the low-side pressure will drop and eventually go into a vacuum. At this point, the system should be checked by a professional who will evacuate the system and change the drier.

E. The condenser works best in front of the radiator with a large supply of fresh air. Abnormally high pressures will result from improper airflow. Check the airflow requirements by placing a large capacity fan in front of the condenser and running cool water over the surface. Pressures dropping significantly will indicate the need for better airflow.

F. Incorrect condenser capacity will cause abnormally high head pressures. A quick test that can be performed is to run cool water over the condenser while the system is operating, if the pressures decrease significantly, it is likely a airflow or capacity problem.

G. An expansion valve failure is generally caused by dirt or debris entering the system during assembly. If an expansion valve fails it will be indicated by abnormal gauge readings. A valve that is blocked will be indicated by high-side that is unusually high and the low-side unusually low (may even go into a vacuum.) A valve that is stuck open will be indicated by both the pressures rising to unusually high readings and tend to move toward equal readings on the gauges.

H. A restriction in the cooling system will cause abnormal readings on the gauges. A high-side restriction, between the compressor and the drier inlet, will be indicated by the excessively high discharge reading. These simple tests can be performed by a local shop and can help determine the extent of the system's problem.

Troubleshooting Your Classic Auto Air A/C System

Problem: system is not cooling properly

Issue: cold at idle. warmer when raising engine RPMs

Make sure the water valve is positioned correctly.

The water valve is a directional valve and should be installed with the arrow pointing towards the water pump. It should be connected to the heater hose that runs from the heater core to the water pump. If the water valve is incorrectly connected to the hose it allows water to circulate through the system via the heater core over-powering the cooling effect of the a/c coil.

Step 1: Check placement of the water valve and correct if needed.

Step 2: If changing the location of the water valve does not rectify the issue, the water valve may be permanently damaged and may need to be replaced. To check the integrity of the water valve you will need to completely remove the heater core's water hoses and "loop" together. By doing so, the heater system will be completely removed from the possibilities. If the system now cools then the water valve will need to be replaced.

Verify adequate air flow to the condenser.

The condenser's function is to dissipate heat. Your air conditioning system will not cool your vehicle's cabin properly if you do not have an adequate airflow across the condenser.

Step 1: Connect gauges to a/c hoses. When ambient temp is 90°, pressures should be:

Low-side pressures: 10-25 PSI

High-side pressures: 150-275 PSI

If the low-side pressures are normal but the high-side pressures are high then there might be an airflow issue and you will need to test the airflow to the condenser.

Test airflow to the condenser.

Step 1: Place a piece of paper on the condenser with the car idling to see if the paper is held in place.

Step 2: With the car still idling, attach gauges and place a large capacity fan in front of the condenser. Check the pressures to see what happens.

Step 3: With the car still idling and the gauges still attached, pour water down the front of the condenser. Check the pressures again to see what happens.

If the paper was held in place then you are getting some air flow. If the high-side decreases during step 2 and step 3 then your condenser is not getting enough air which is stopping your system from cooling properly. To correct this issue, you will need a more powerful mechanical fan.

Confirm the correct refrigerant charge is in the system.

All of our systems should be charged with 1.5lbs (24oz) of R134a refrigerant only. If overcharged, you will need to evacuate the system and recharge with the correct amount.*

Measurement meanings:

1. Low temp and high pressure seems to be equal = malfunctioning expansion valve that is stuck open.
2. High side is extremely high and low side is extremely low (possibly into vacuum) = blockage in the system. Remove hoses and blow cold compressed air through it in both directions. Re-check your pressures. If pressures do not change then it is possible that your expansion valve is stuck closed and would have to be replaced.

***Compressor Concerns:**

If you have a noisy compressor, it is due to the improper charging with liquid or overcharging. An overcharged compressor will cause rattling. A compressor charged with pure liquid produces a high probability of bent reed valves. When the reed valves get bent they will create a tapping sound. Ensure your system is charged with 1.5lbs (24oz) of R134a refrigerant to avoid compressor related cooling issues.

