

#TL100089



B9 A4 INTERCOOLER SYSTEM/  
INSTALLATION INSTRUCTIONS

**APR**



---

Notes:

These instructions were written for a North American specification B9 Audi A4, but other models, like the allroad and A5 are similar.

When disassembling the car, be sure to keep all fasteners so they can be reused. It is recommend that you get some kind of compartmented tray to organize the fastners, such as a fishing tackle box or several large ice cube trays. Fasteners that are not reused for reinstallation are noted in the instructions. All directions used in this manual (right, left, front, etc.) are based on if you were sitting in the drivers seat of the car.

These instructions assume that you have basic mechanical skills and several varieties of basic hand tools in order to install the kit. If you have any questions about the install, feel free to contact your APR representative.



WWW.GOAPR.COM

4800 US HWY 280 West Opelika Alabama 36801

**TL100089**

---



1) Place the vehicle securely on jack stands or on a lift, remove the front wheels, and raise the hood of the vehicle.

***APR***

2) Remove the two 10mm plastic nuts from the plastic axle shield inside the wheel well. Remove the plastic axle shield from the car. Repeat on both sides of the car.



**TL100089**

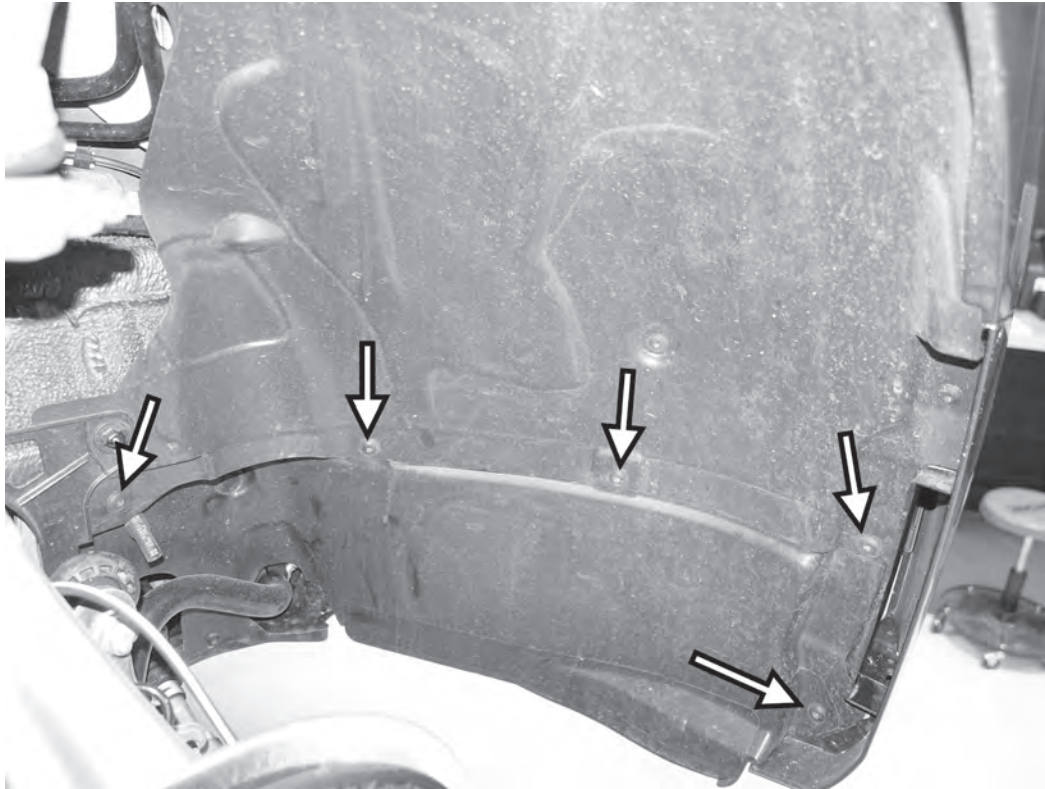

3) On both sides of the car, remove the five T25 screws from the lower section of the wheel well liner.

4) On both sides of the car, remove the T30 plastic screw from the bottom of the wheel well liner. After carefully separating the lower liner from the upper liner, pull the plastic push barb fitting from the upper, inner side of the wheel well liner.



**TL100089**

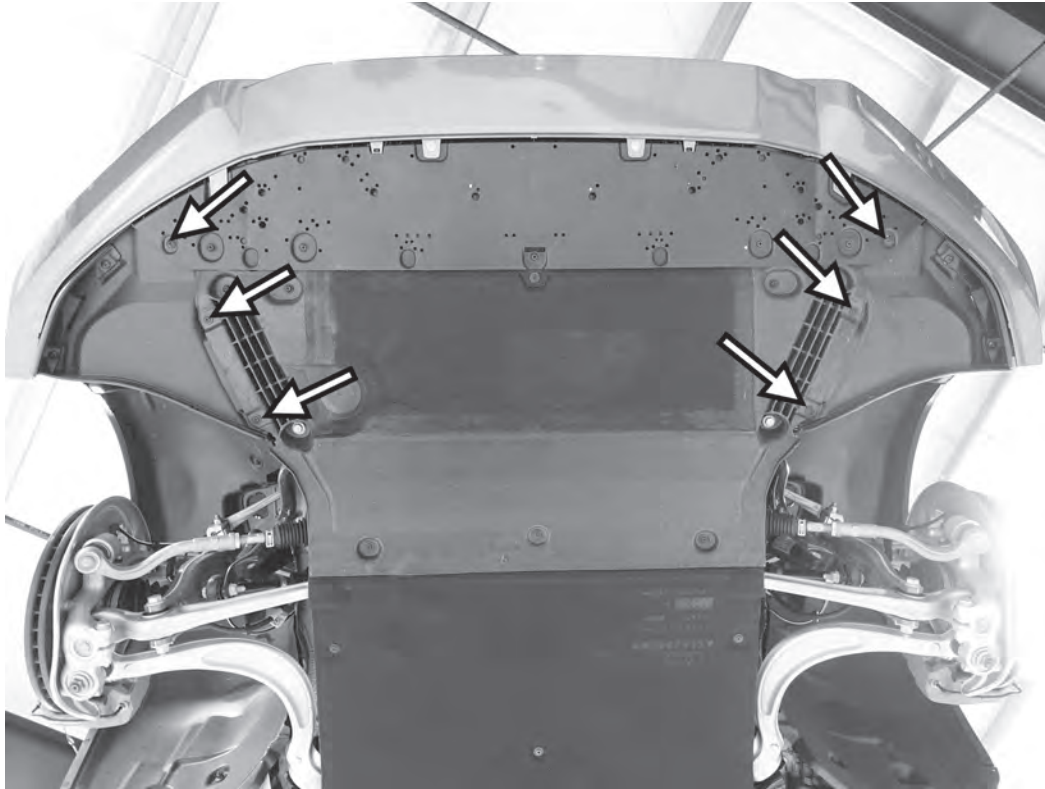

5) Disconnect the four quarter turn T25 screws and two T25 screws holding the lower wheel well liners to the engine belly pan.



6) Remove the five T30 screws that run between the bottom of the front bumper cover and the underbelly pan.

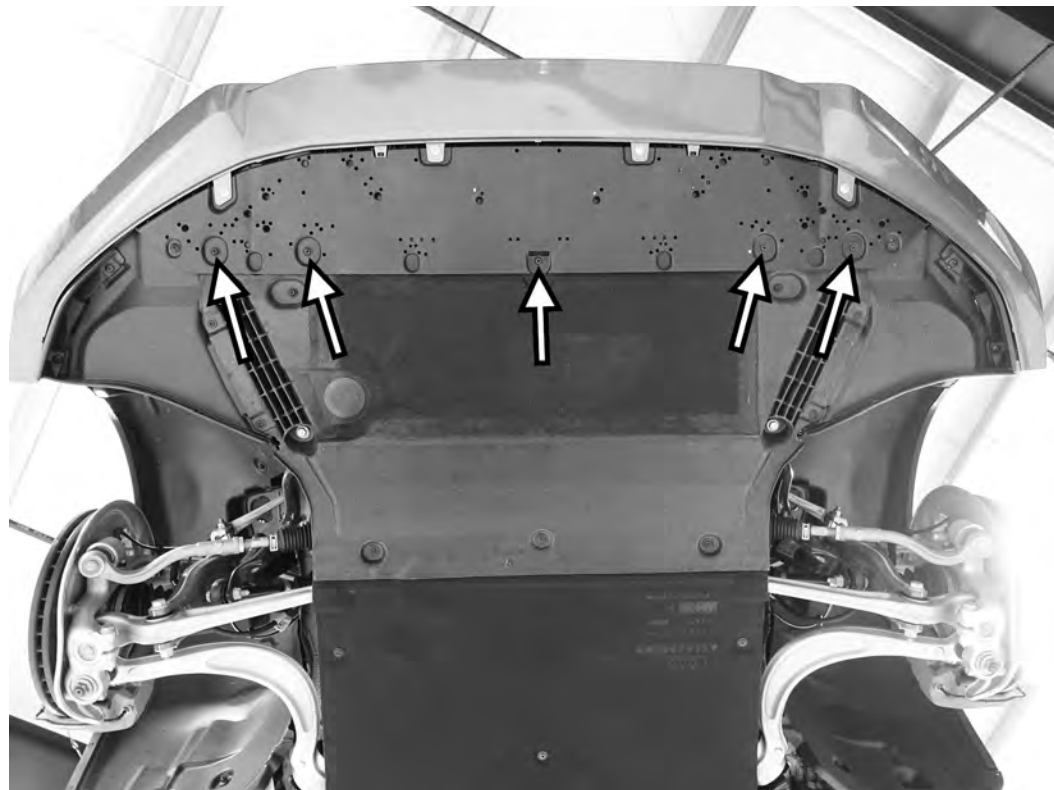

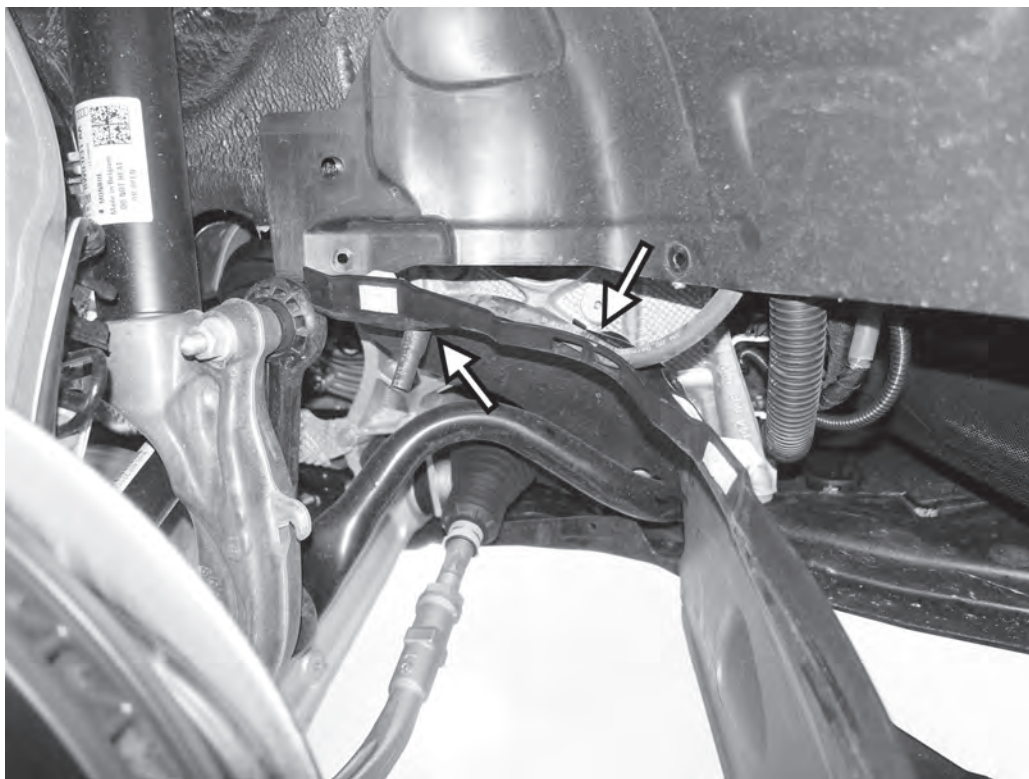

7) On both sides of the car, separate the drain line from the lower wheel well liner and remove the liner from the car.

8) On both sides of the car, remove the two T25 screws and the one 10mm nut from the front of the wheel well liner.

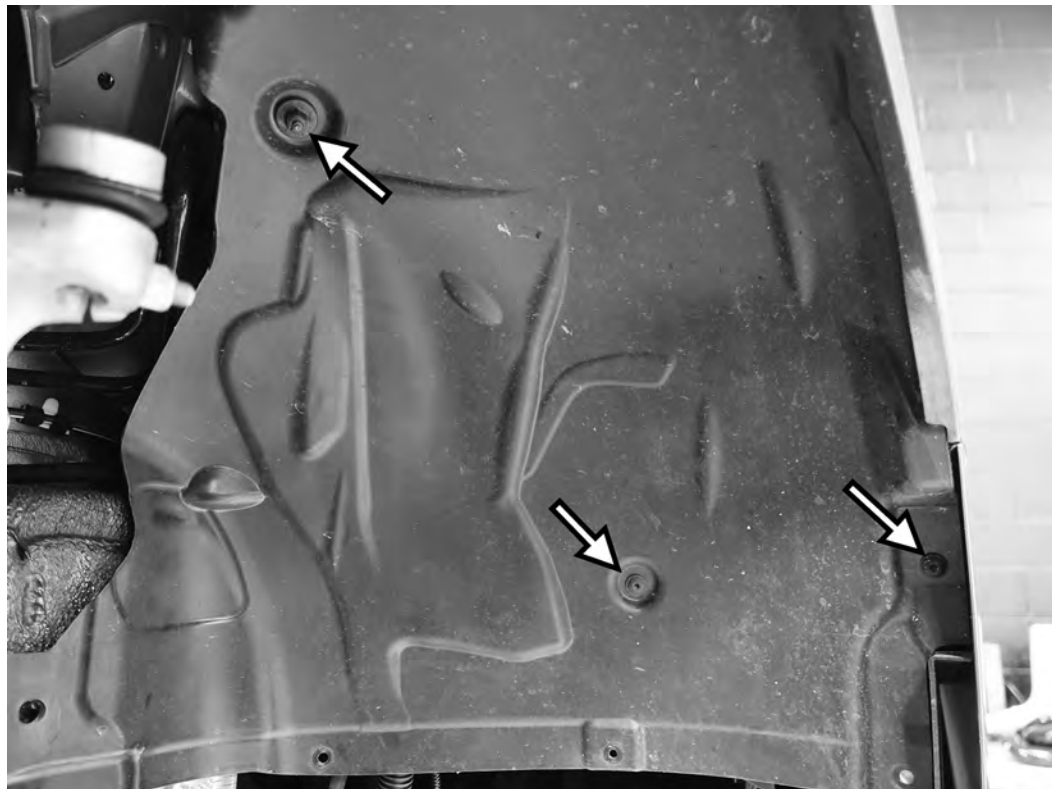

**TL100089**

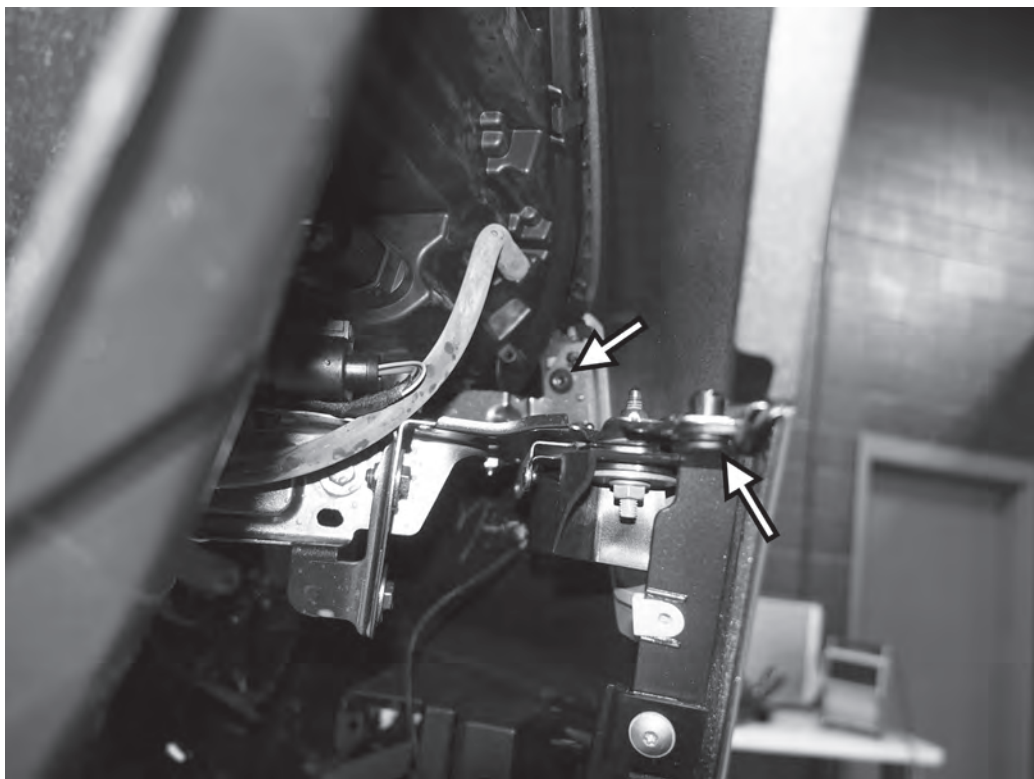

9) After carefully folding back the front of the wheel well liner, remove the T30 screw holding the front of the fender to the back of the bumper cover. Also remove the plastic push-pin clip from between the fender and bumper cover. Repeat on both front wheel wells.

10) Push in the button on the back of the hood lever, and lift up on the lever to remove from the car.



**TL100089**



11) Lift up on the front of the upper bumper cover to separate from the bumper, and then pull forward to remove from the car.

***APR***

12) Remove the four T30 screws holding the top of the front bumper cover to the bumper latch support.



**TL100089**



13) Pull both right and left edges of the bumper cover away from the sides of the front fenders.

***APR***



14) With an assistant, pull the bumper cover away from the front of the car.



**TL100089**



15) Disconnect the electrical connector from the back side of the bumper cover, and set the bumper cover out of the way so it will not get damaged or scratched.

16) Remove the two hose clamps from the stock turbo to intercooler outlet hose, and remove the hose from the car.



**TL100089**

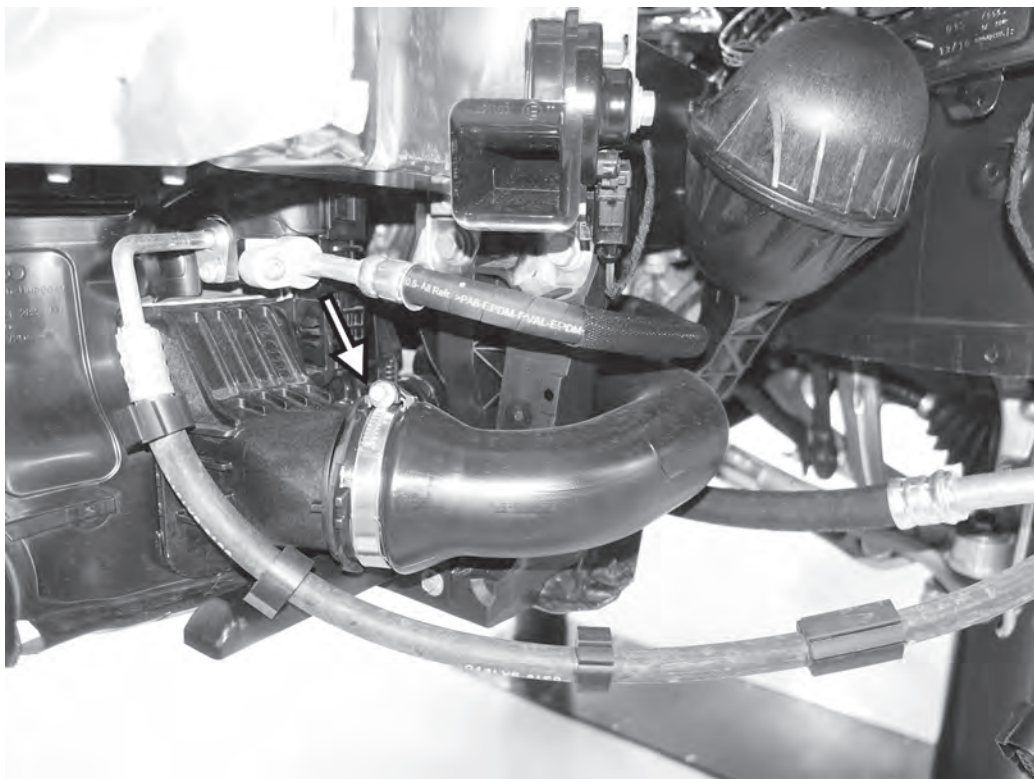

17) Loosen the hose clamp from the outlet of the intercooler to the stock inlet pipe and separate the pipe from the intercooler.

18) Loosen the hose clamp from the stock inlet pipe to the throttle body. Disconnect the electrical connector to the MAP sensor mounted in the stock inlet pipe.





19) Separate the stock inlet pipe from the throttle body, and then pull the pipe out of the car from the front of the car. The large sound resonance chamber will also be removed.

20) Remove the stock MAP sensor from the inlet pipe by rotating the sensor counterclockwise a quarter turn and then pulling the sensor out of the pipe.



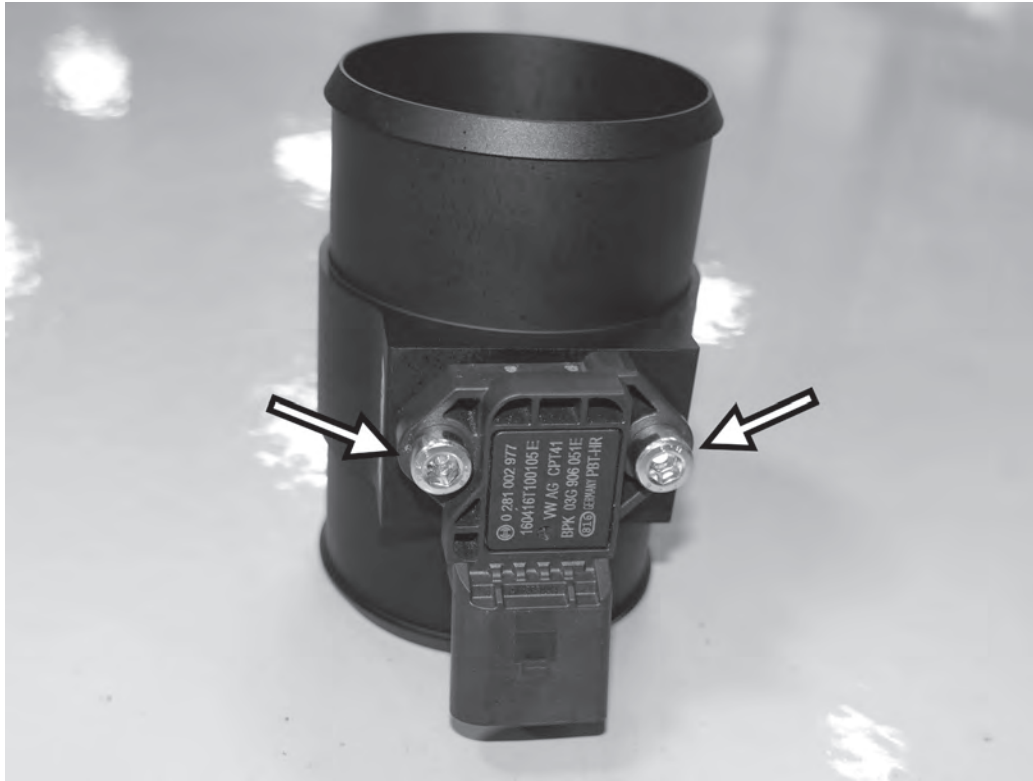

21) Lubricate the o-ring on the MAP sensor, and install into the APR MAP sensor housing. Orient the sensor so the body of the sensor is not hanging off of the mounting flange of the APR sensor housing. Secure with the two supplied 5mm allen screws.

**APR**



22) Install the two hoses onto the APR MAP housing as shown. The APR logos on both hoses should be on the opposite end of the hose from the sensor housing. Loosely place a 3" (-0300) hose clamp on the end of the Z1002981 hose, where the throttle body will be. Place a 2 5/8" (-0262) on the end of the Z1002979 hose, where the intercooler outlet will be.



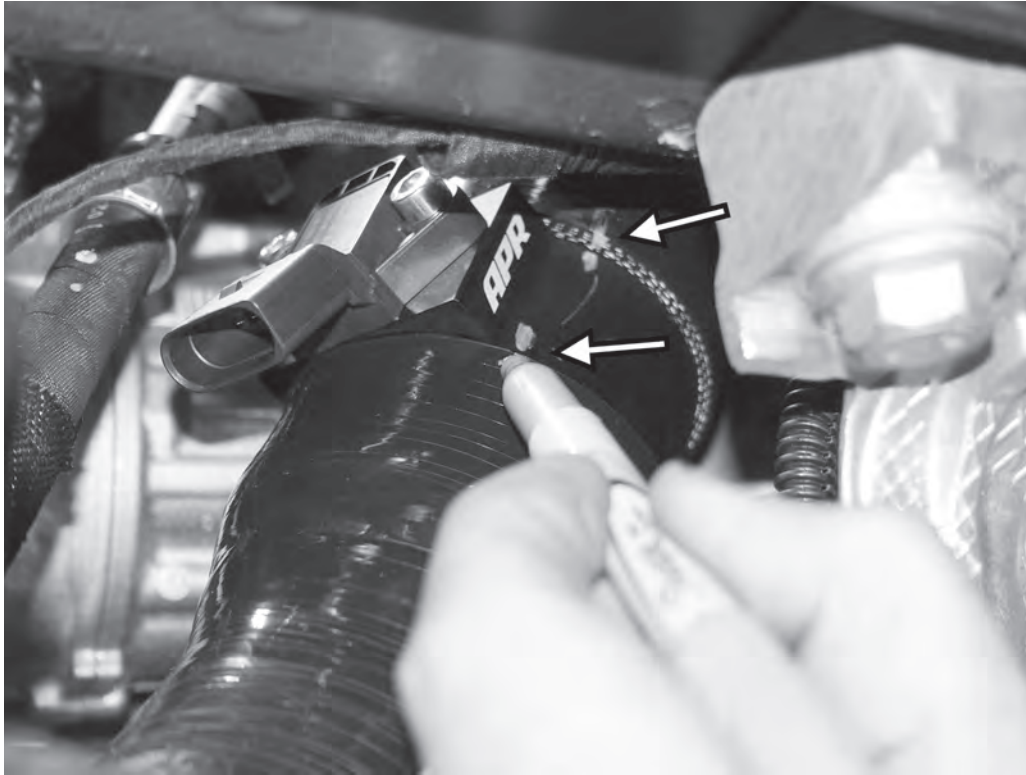

23) Place the APR hose assembly in the car the same way the stock one came out. Connect the end of the Z1002981 hose to the throttle body, and then rotate both hoses and the MAP housing so they fit well and do not heavily rub on anything in the engine bay. Use a sharpie or paint marker to mark the orientation of the MAP housing to the two hoses.

**APR**

24) Pull the inlet hose assembly back out of the car. After making sure the alignment marks you made are lined up correctly, install two of the 3" (-0300) hose clamps onto the two hose connections by the MAP housing. Torque the T-bolt clamps to a maximum of 50 in-lbs (5.7Nm). The marks made by orienting the hoses can be removed with cleaning solvent, like brake parts cleaner.



**TL100089**

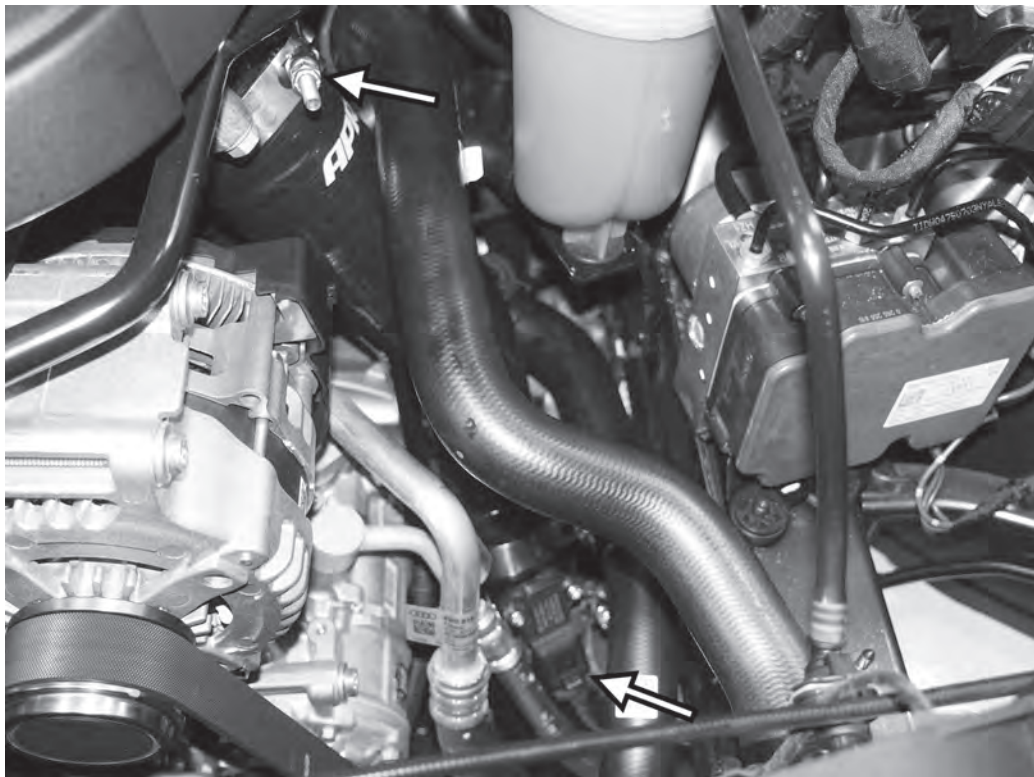

25) Reinstall the hose assembly in the car, connecting the upper hose to the throttle body. Make sure the two hose clamps just installed are not rubbing on anything. Fully install the upper clamp on the throttle body and tighten the T-bolt clamp to a maximum of 50 in-lbs (5.7Nm). Reconnect the electrical connector to the factory MAP sensor.

26) Remove the right plastic air guide that runs up and down the right, front side of the factory radiator and intercooler. Push in on the two tabs where the air guide connects to the radiator core support, pull the air guide forward, and then manipulate the air guide out of the car.



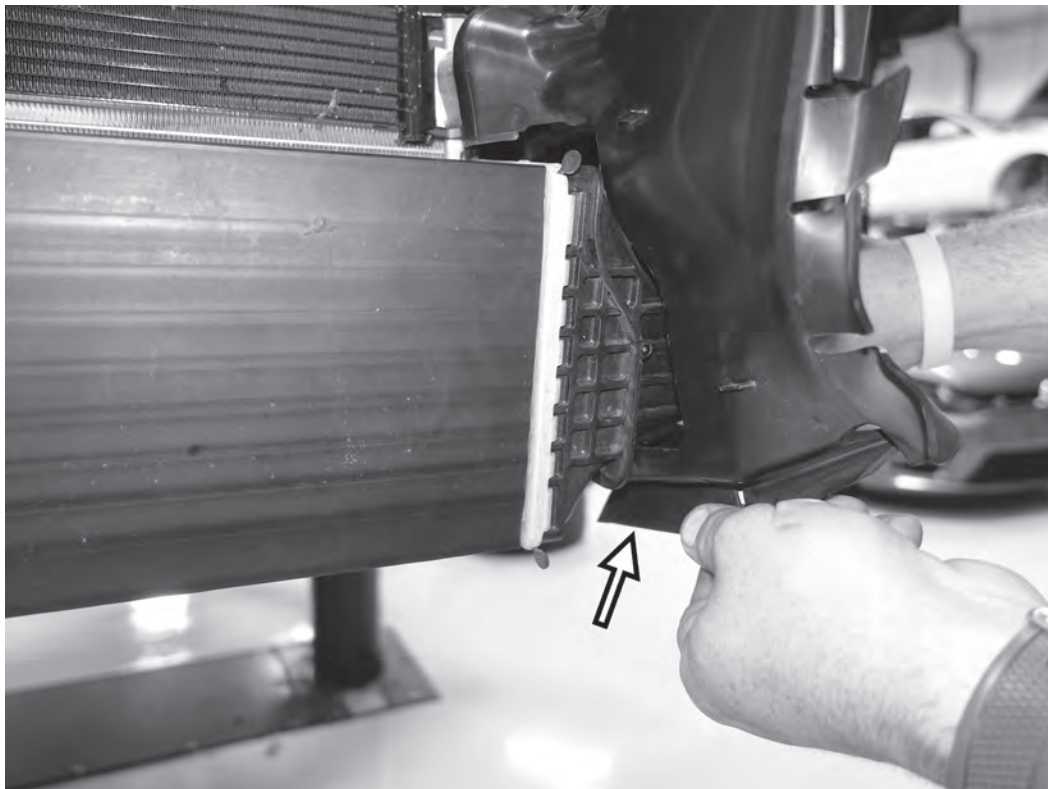

27) Separate the lower portion of the left air guide from the bottom of the intercooler.

28) Squeeze the release clip holding the right side of the intercooler to the core support, and then carefully use a screwdriver to pry the top of the stock intercooler forward. Repeat on the left side of the intercooler.

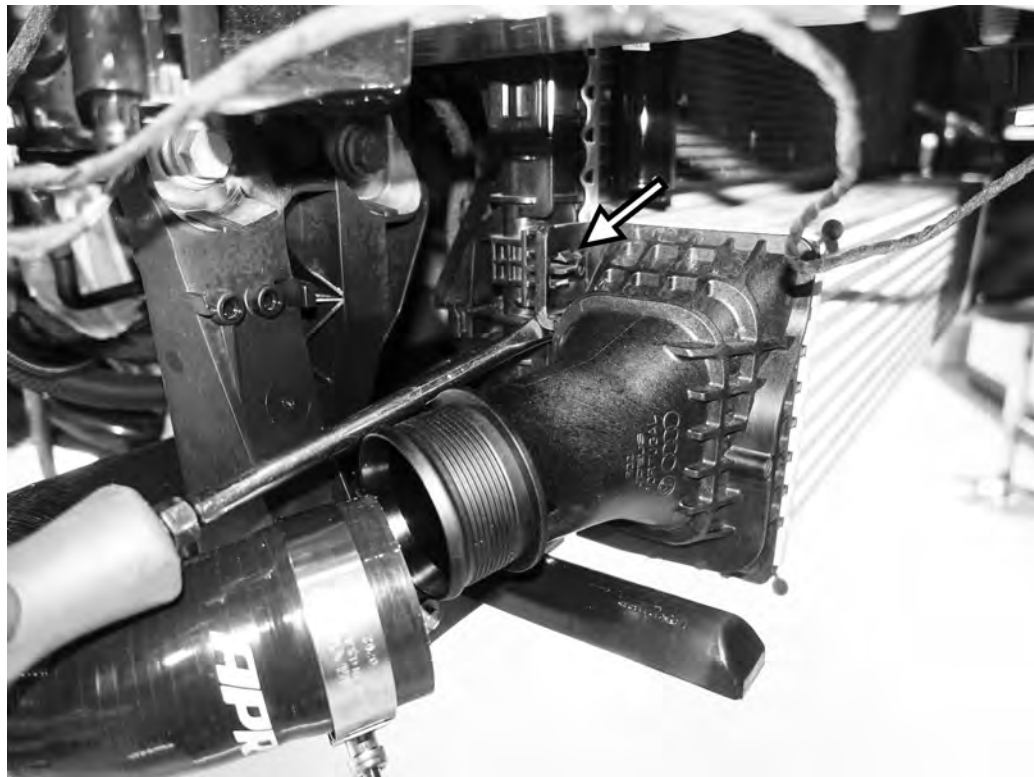

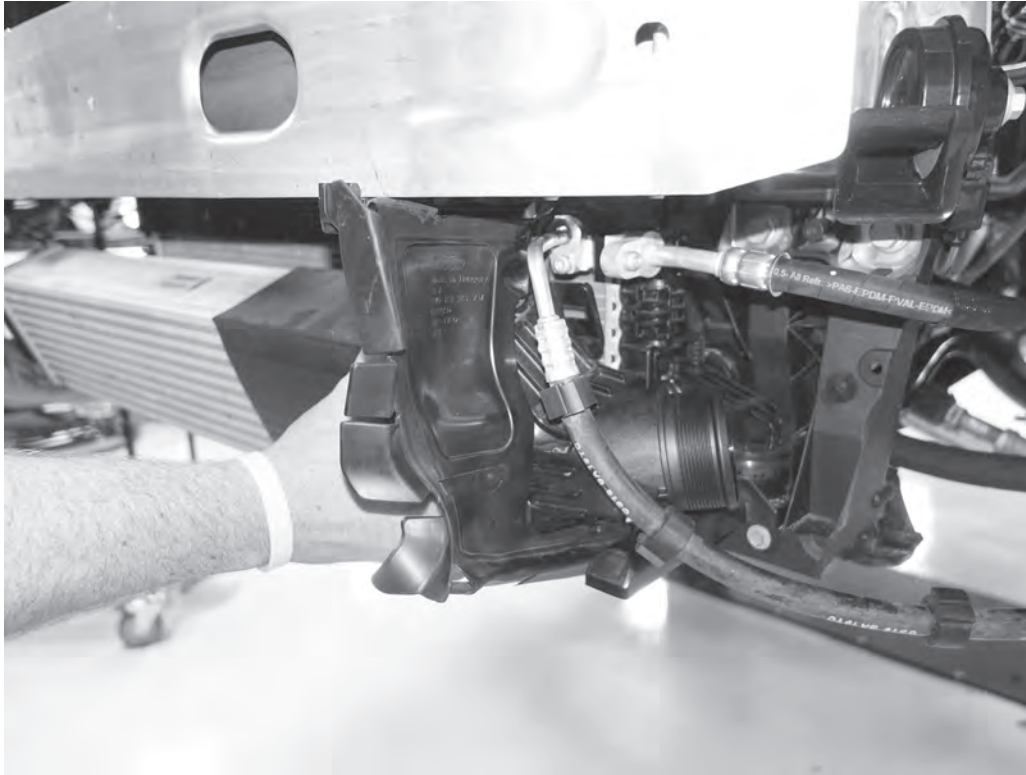

29) Carefully swing the top of the stock intercooler away from the core support. Lift up to separate the intercooler from the core support. Remove the stock intercooler from the car, maneuvering out of the left air guide.



30) Using one the longer of the four supplied 13mm bolts with a washer, loosely mount the right APR inter-cooler bracket to the lower mounting point of the right side of the APR intercooler.

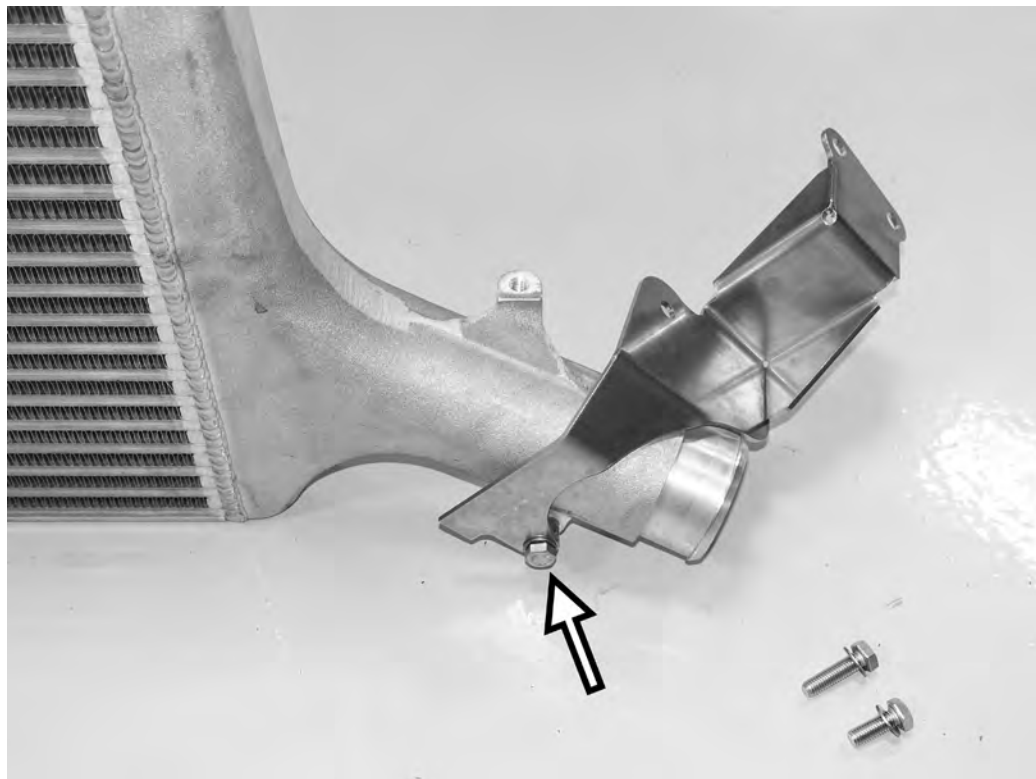

**TL100089**

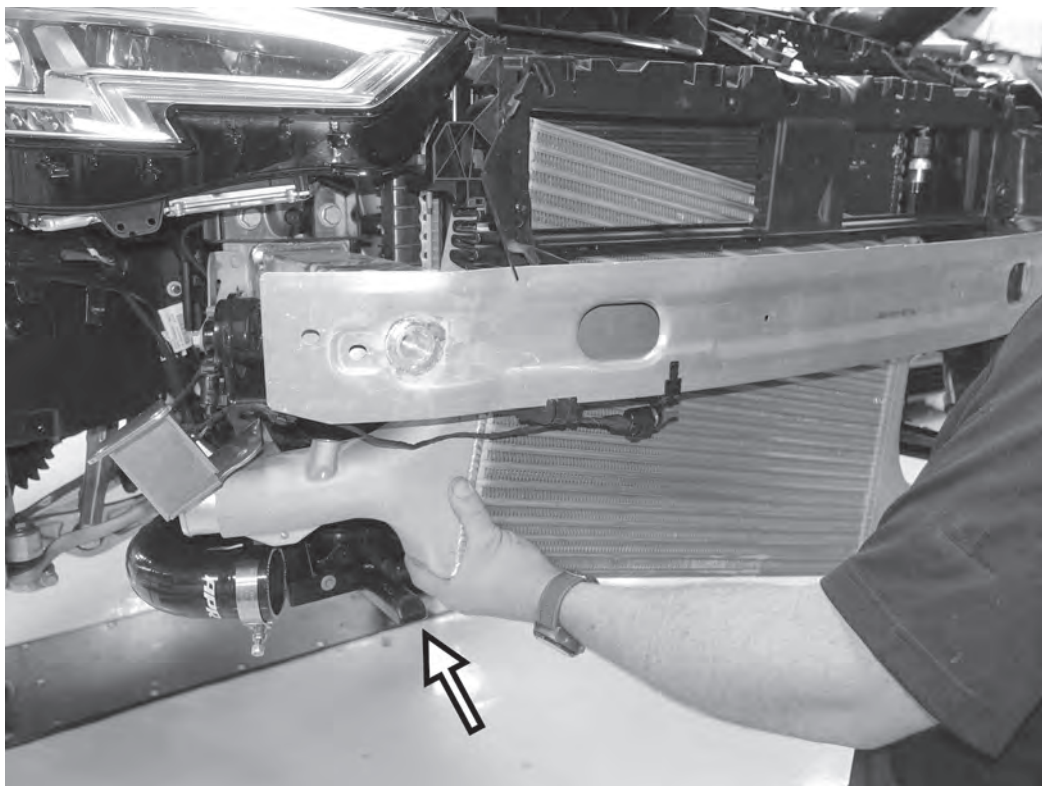

31) Carefully maneuver the APR intercooler up behind the front crash beam. Make sure the left side of the intercooler goes through the hole in the left air guide that the factory intercooler went through. Once in place, it is OK to temporarily “rest” the intercooler on the two lower bumper supports.

**APR**

32) Remove the four (two on each side) 13mm nuts and bolts holding the bumper crash beam to the front frame rail extensions.

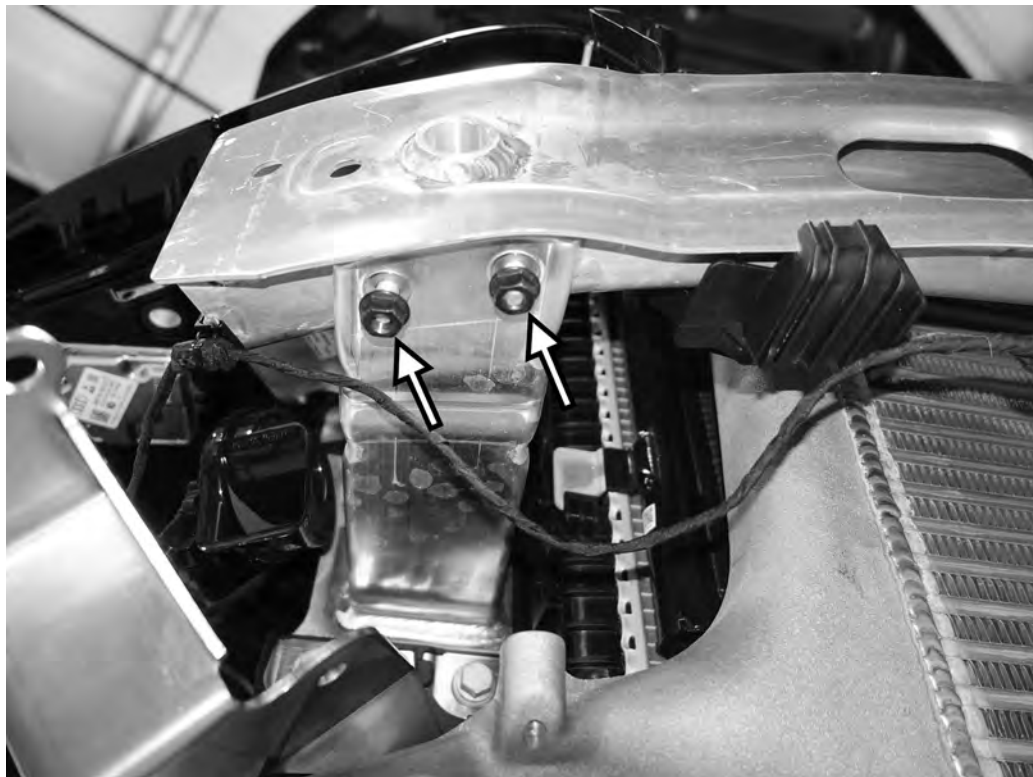

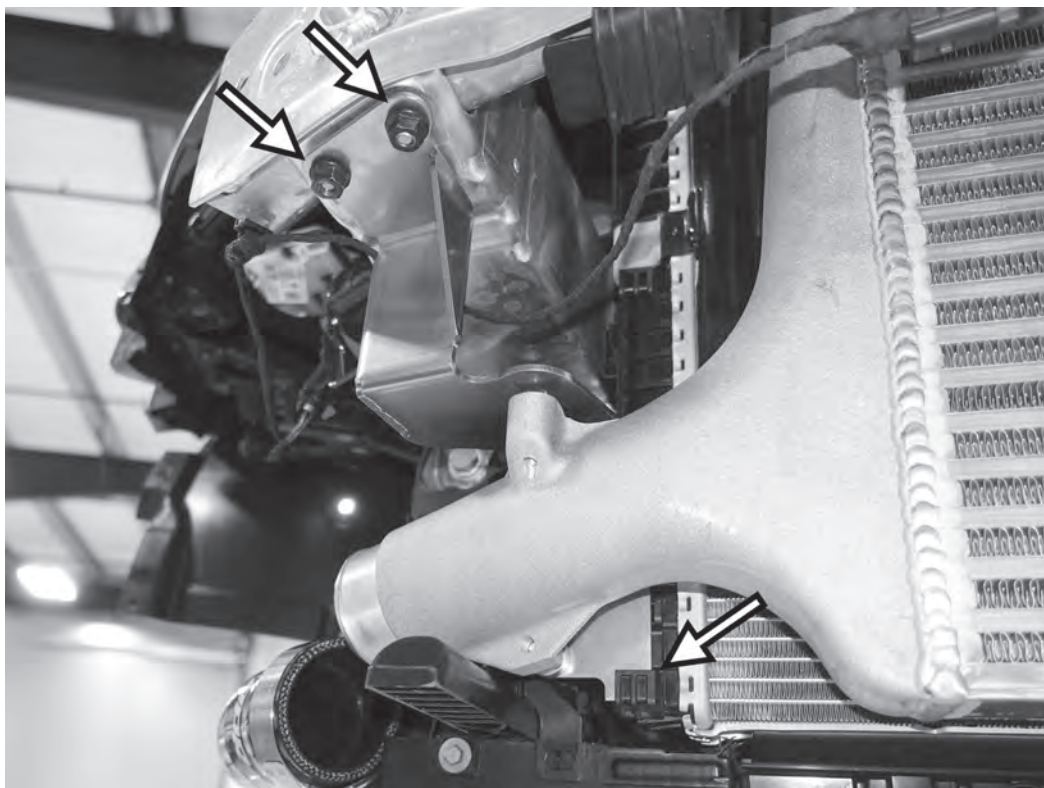

33) Swing the right APR intercooler up to its correct mounting place. Make sure the lower tab of the APR bracket sits in the slot of the stock radiator, as the stock intercooler did. Very loosely reinstall the two factory right side 13mm nuts and bolts through the crash beam, through the front frame rail extensions, and through the APR intercooler mounting brackets.

**APR**

34) Loosely install one of the shorter supplied 13mm bolts with a washer to the right APR bracket to the upper mounting point on the right side of the APR intercooler.



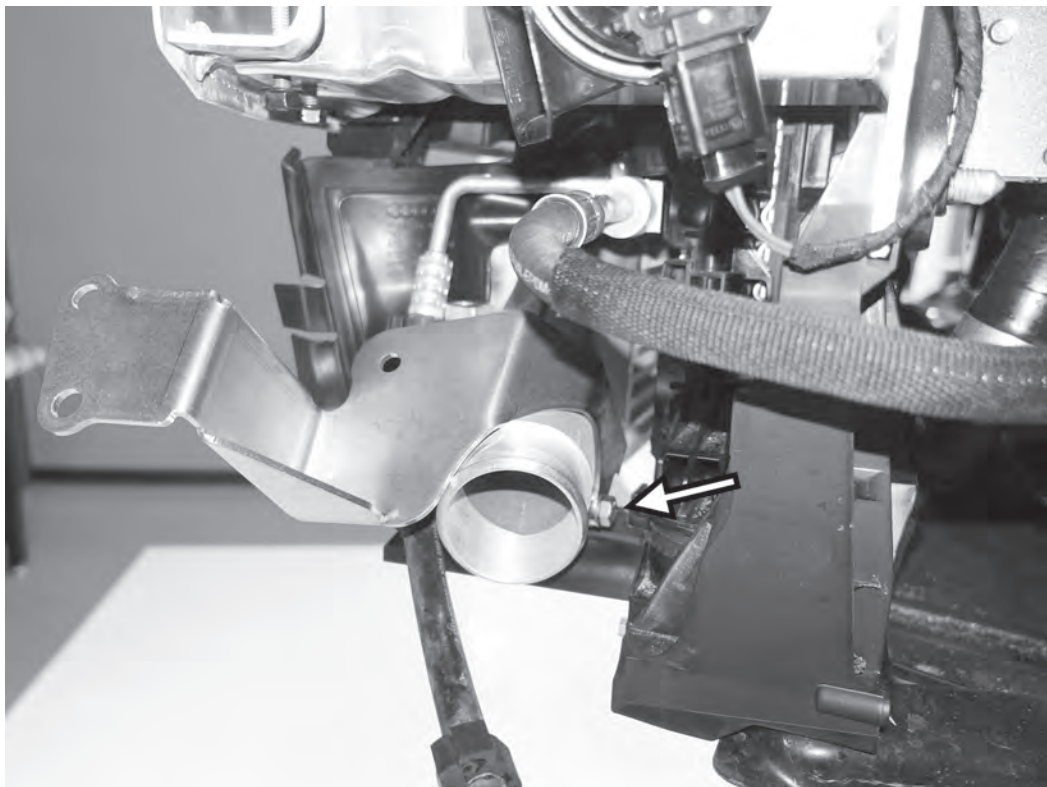

35) Install the left APR intercooler mounting bracket to the lower mounting point with the last of the supplied, longer 13mm bolts and a washer.

***APR***

36) Swing the left APR intercooler up to its correct mounting place. Make sure the lower tab of the APR bracket sits in the slot of the stock radiator, as the stock intercooler did. Loosely reinstall the two factory left side 13mm nuts and bolts through the crash beam, through the front frame rail extensions, and through the APR intercooler mounting brackets.

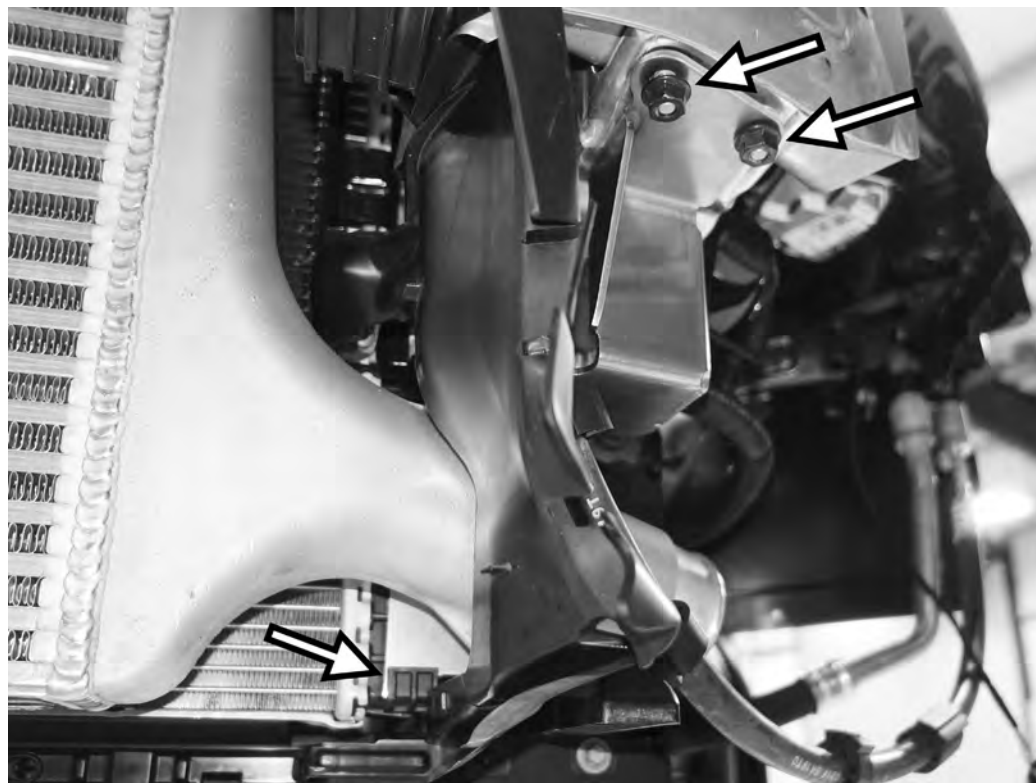

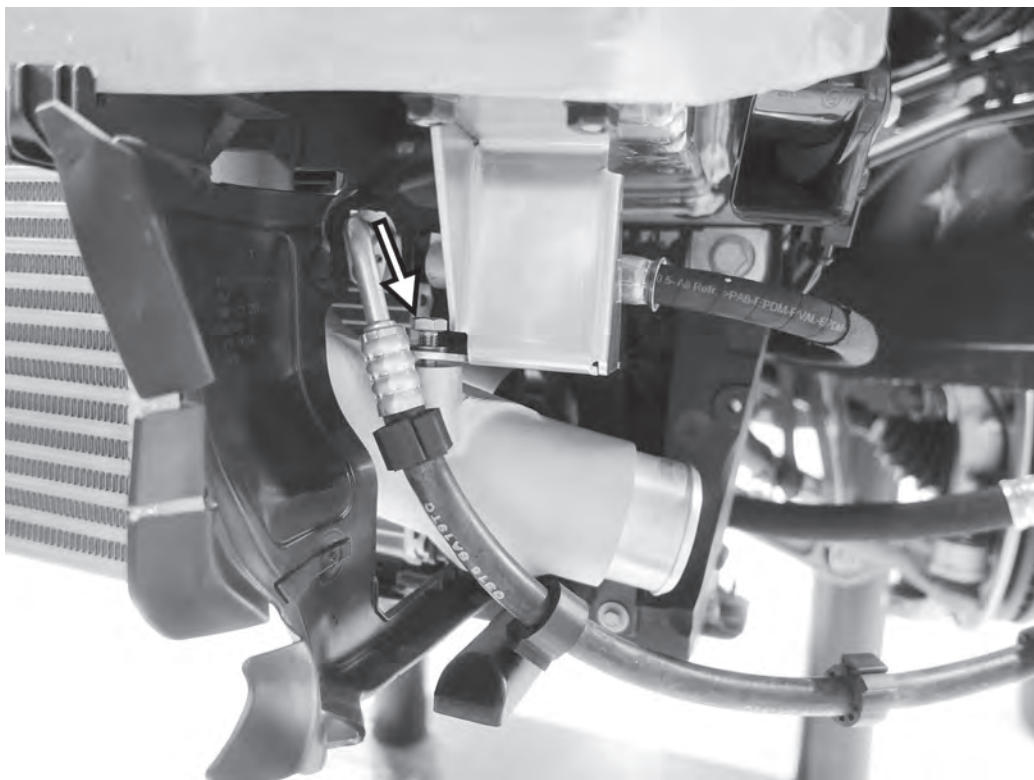

37) Loosely install the last of the shorter supplied 13mm bolts with a washer to the left APR bracket to the upper mounting point on the left side of the APR intercooler.

**APR**



38) Reinstall the right radiator air guide similar to how it was removed. Be sure to snap the air guide into the two factory mounting points on the radiator support.



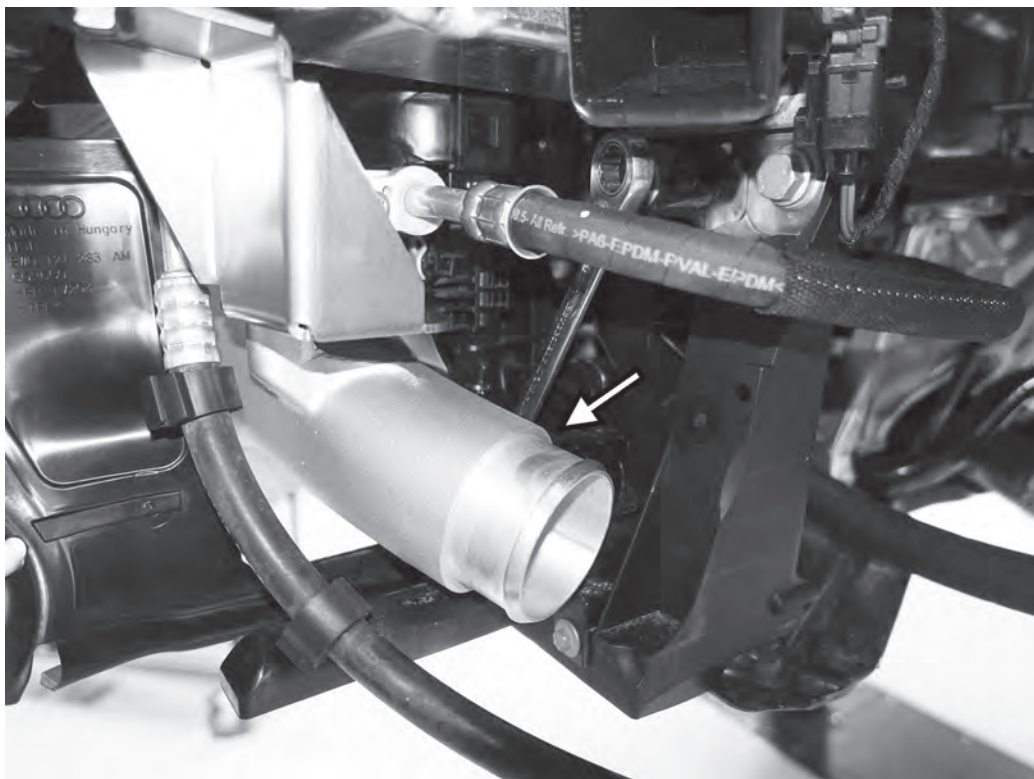

39) Tighten the two lower 13mm bolts holding the APR mounting brackets to the APR intercooler. Once the lower are tight, tighten the two upper 13mm bolts on the mounting brackets.

**APR**

40) Torque the four factory 13mm nuts and bolts on the bumper crash beam to 17 lb-ft (23Nm).

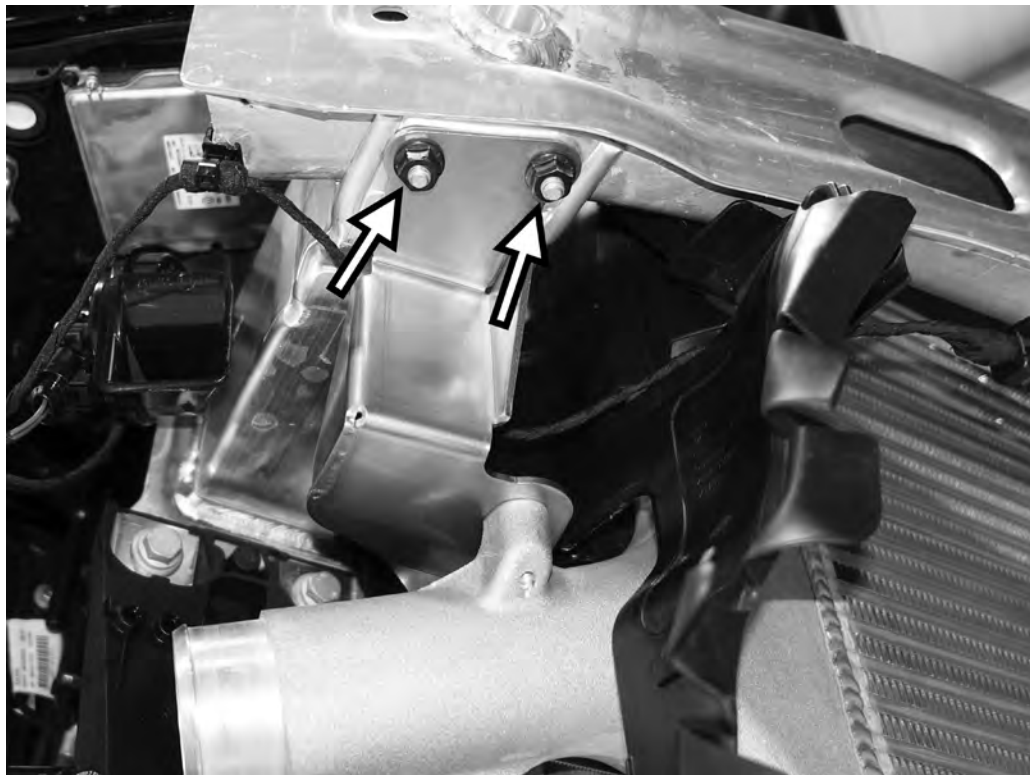

**TL100089**

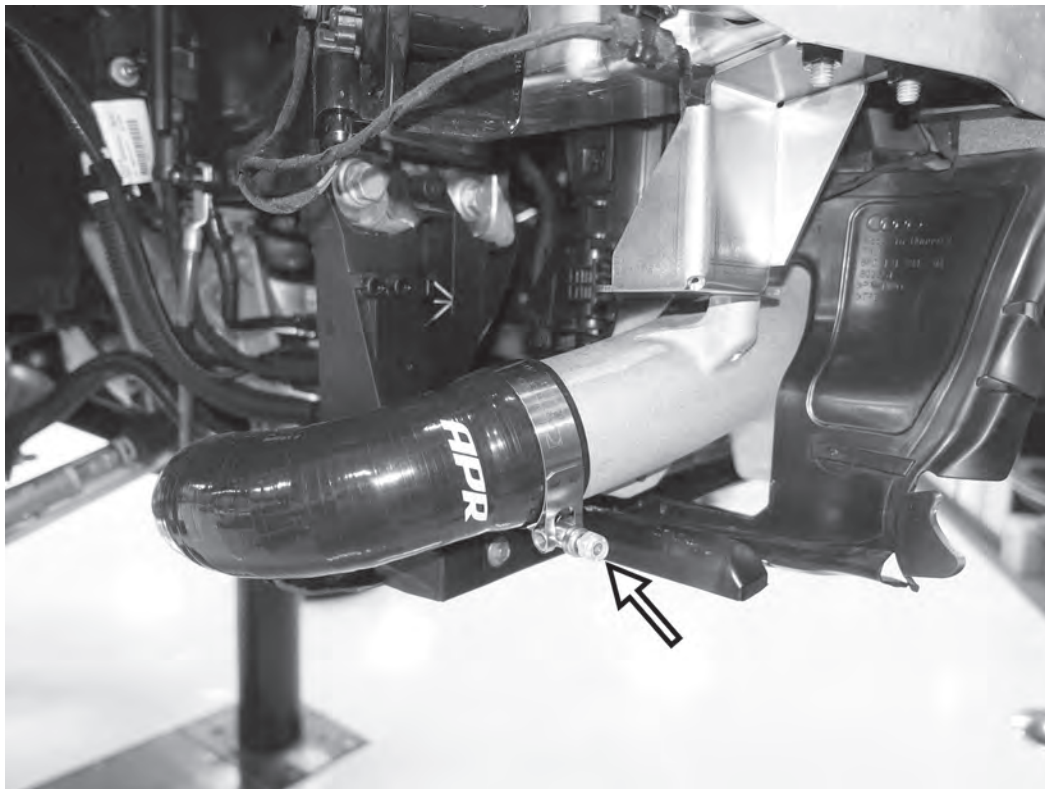

41) Install the APR hose that runs from the turbo outlet to the intercooler inlet. Secure the turbo end with a 2 1/4" (-0225) clamp. Secure the intercooler end with a 2 5/8" (-0262) clamp. Tighten the two T-bolt clamps to a maximum of 50 in-lbs (5.7Nm).

**APR**

42) Connect the previously installed APR hose to the intercooler outlet, and secure with the 2 5/8" (-0262) hose clamp. Tighten the hose clamp to a maximum of 50 in-lbs (5.7Nm).



**TL100089**

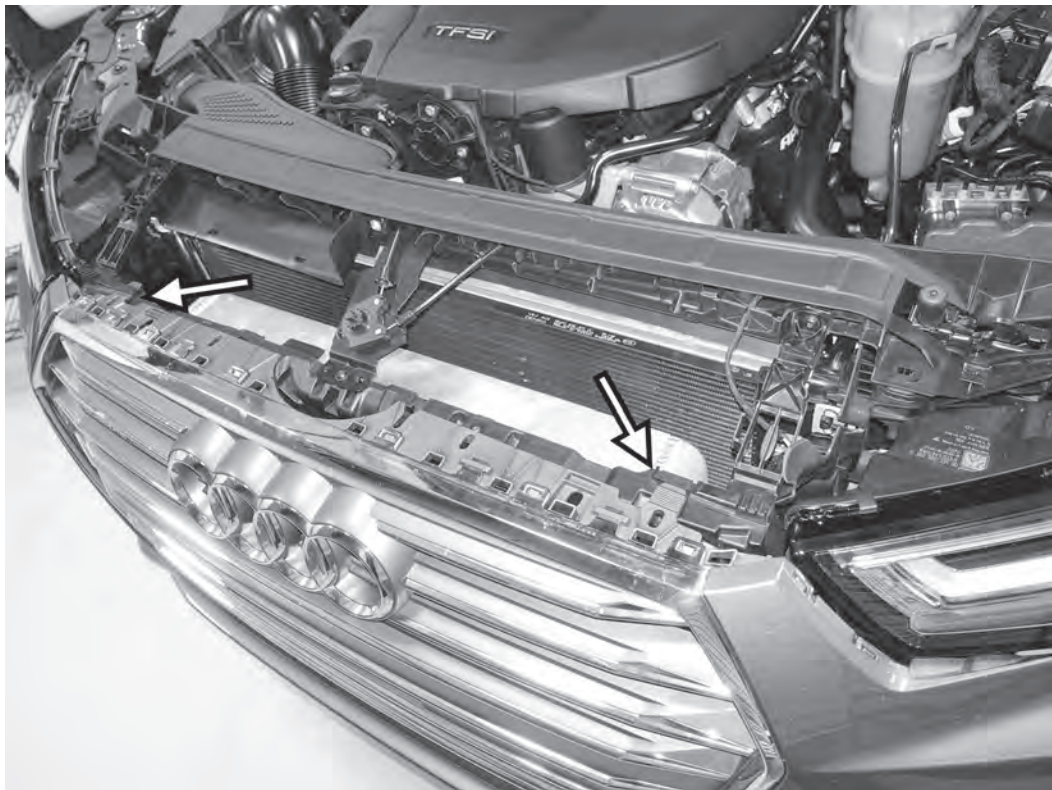

43) With an assistant, bring the bumper cover back to the front of the car. Reconnect the electrical connector on the left side of the bumper cover, and then place the bumper cover back on the car. Make sure the tabs on the top of the bumper go into the slots on the top of the bumper support.

44) Snap both sides of the bumper cover to the mounting brackets on the side of both front fenders.



**TL100089**

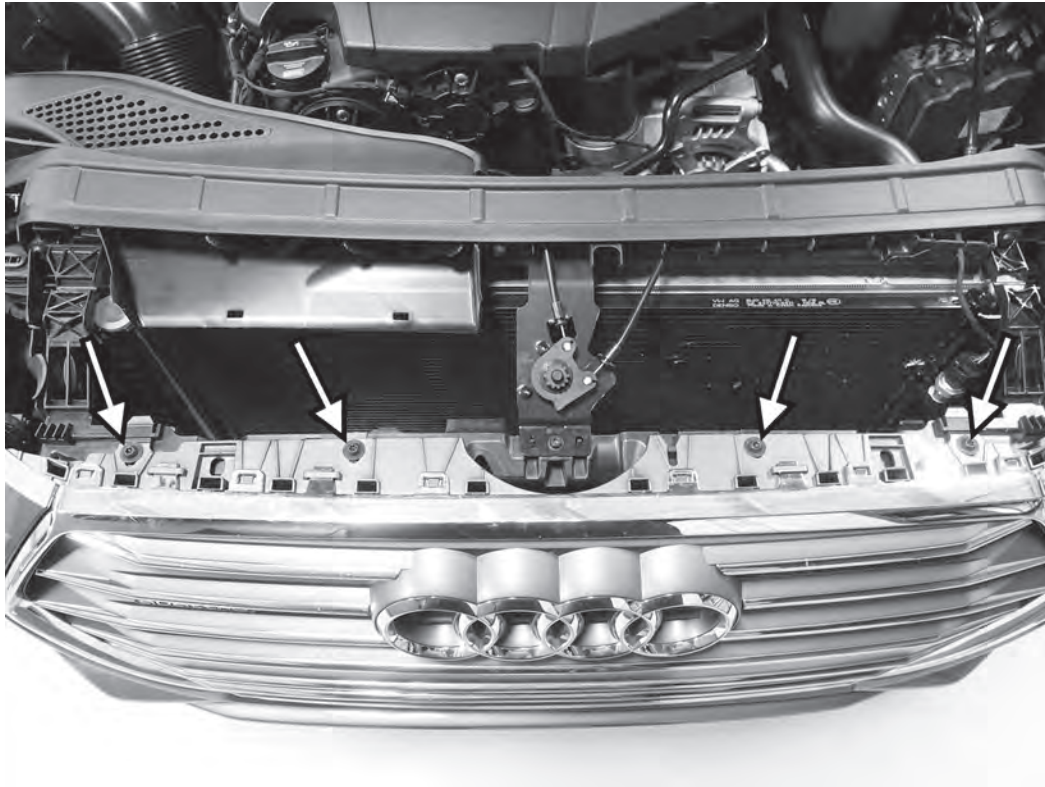

45) Install the four T30 screws holding the top of the bumper cover to the bumper latch support.



46) Slide the upper bumper cover back into the slot on the front side of the radiator core support. Lower the upper bumper cover down, snapping into place along the top of the front bumper cover.



**TL100089**



47) Reinstall the hood latch by simply pushing the keyed latch down on the keyed post for the hood latch assembly.

48) On both sides of the car, fold back the front wheel well liner again, and reinstall the one T30 screw holding the front of the fender to the back of the bumper cover. Install the one plastic push pin clip between the fender and bumper cover.



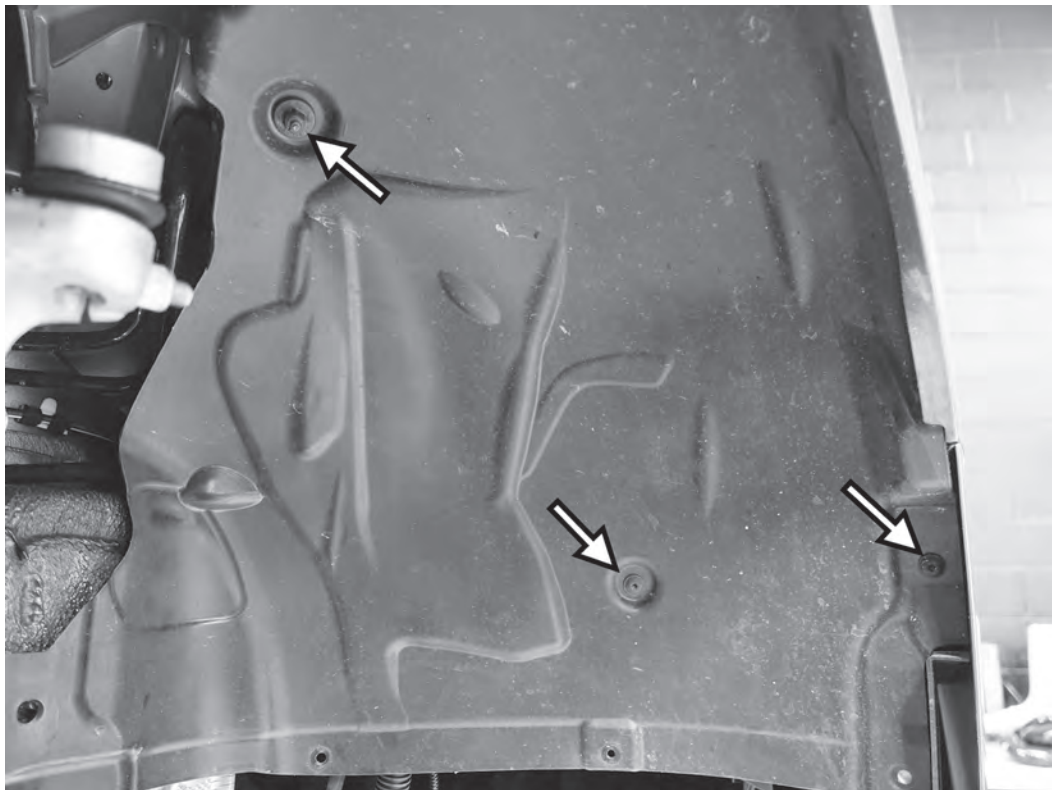

49) On both sides of the car, install the two T25 screws and one 10mm nut holding the front of the wheel well liner in place.

**APR**

50) Reinstall the drain line to the lower wheel well liner on both sides of the car.

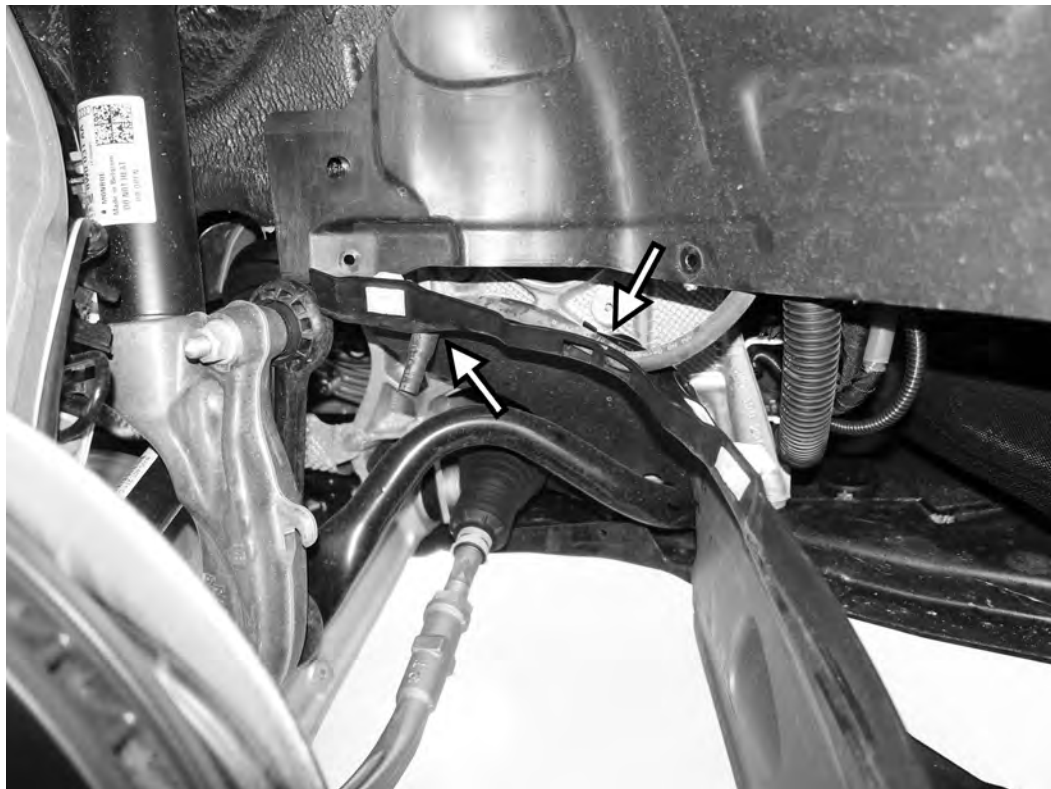

**TL100089**

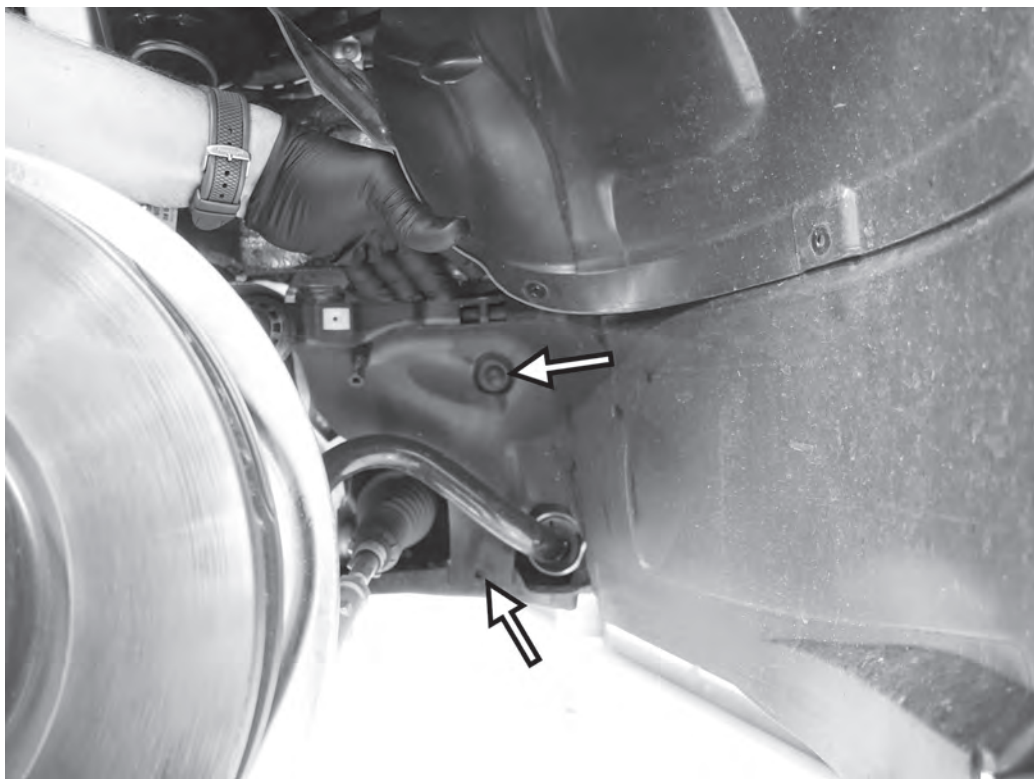

51) On both sides of the car, reinstall the plastic push pin barbed fitting from the upper, inner side of the wheel well liner. Also install the T30 plastic screw from the lower wheel well liner.

52) Reinstal the five T30 screws that run between the bottom of the front bumper cover and the underbelly pan.

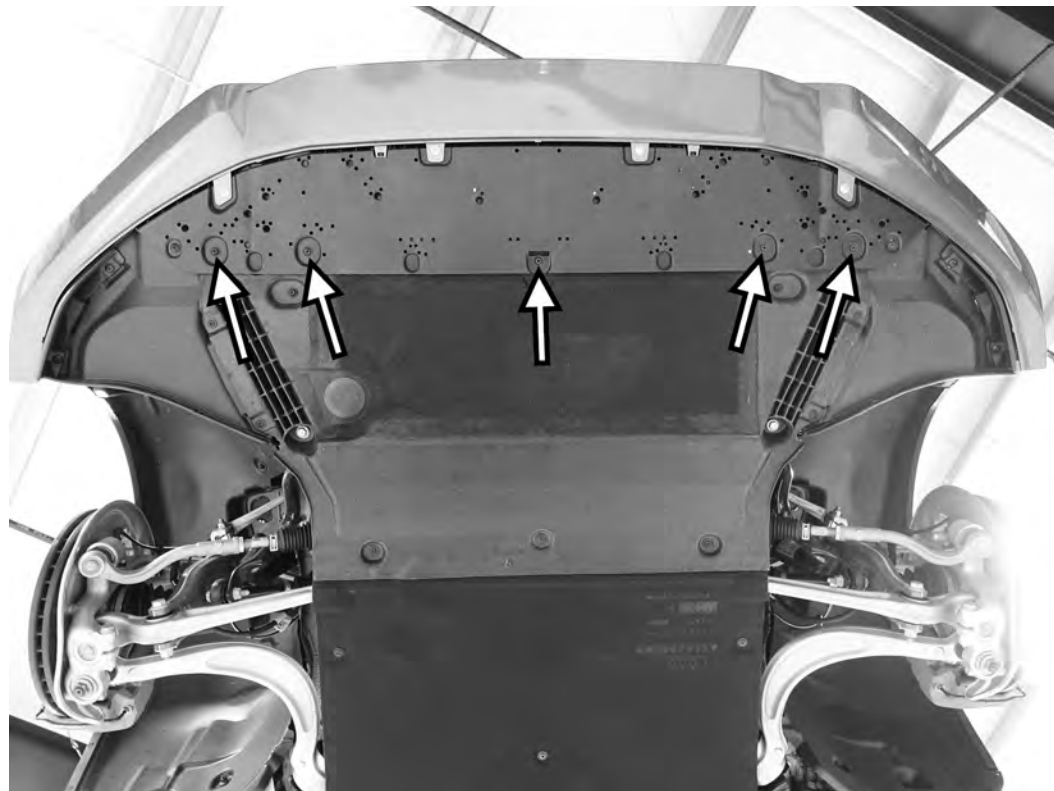

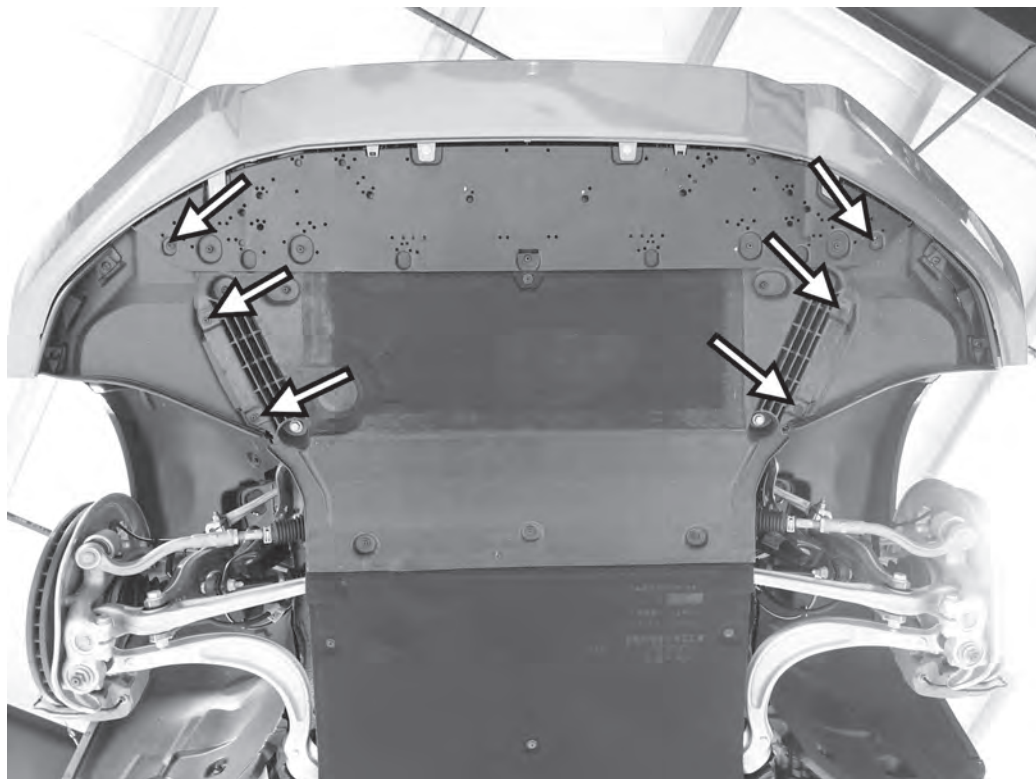

53) Reinstall the four quarter turn T25 screws and the two T25 screws holding the lower wheel well liners to the engine belly pan.



54) On both sides of the car, install the five T25 screws holding the lower wheel well liners to the front wheel well liners.

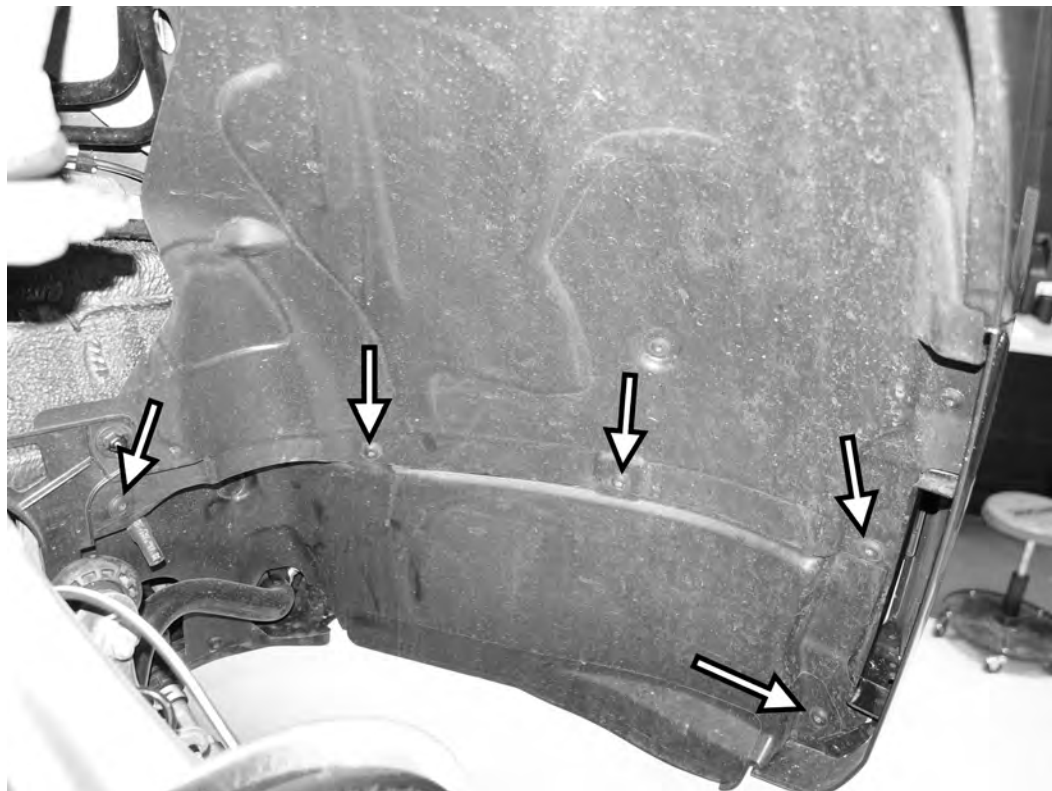

**TL100089**

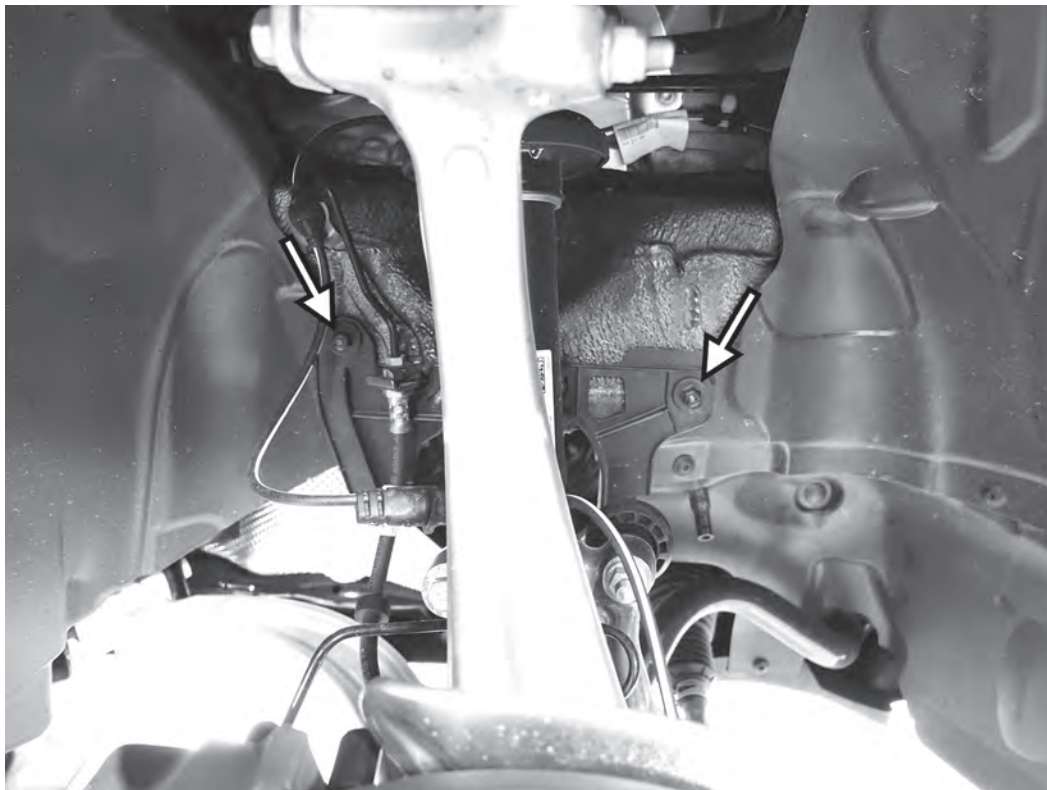

55) Reinstall the plastic axle shield to both sides of the car, and secure with the two 10mm plastic nuts.

56) Reinstall the front wheels and torque to 88 lb-ft (120Nm). Remove vehicle from lift or jackstands.



**TL100089**

---

---

***APR***

---



#LT10089



**APR**

INSTALLATION INSTRUCTIONS  
B9 A4 INTERCOOLER SYSTEM