

#TL100036



B8/B8.5 A4/A5 INTERCOOLER SYSTEM/
INSTALLATION INSTRUCTIONS

APR

Notes:

These instructions were written for an Audi A4, but other models (Audi Q5, etc.) are similar.

When disassembling the car, be sure to keep and mark all fasteners so they can be reused. It is recommended that you get some kind of compartmented tray to organize the fasteners, such as a fishing tackle box or several large ice cube trays. Fasteners that are not reused for reinstallation are noted in the instructions.

These instructions assume that you have basic mechanical skills and a variety of the tools listed in order to install the kit. If you have any questions about the install, feel free to contact your APR representative.



1) Securely lift vehicle. If a vehicle lift is not used, secure the vehicle with jack stands. Remove both front wheels.

2) Disconnect the three T25 Torx screws and two push tabs that hold the front half of left front fender liner to the car. Carefully bend the liner back behind the brake rotor so that it is out of the way. The B8.5 cars only have one push tab. Perform this step on the right front fender liner as well.

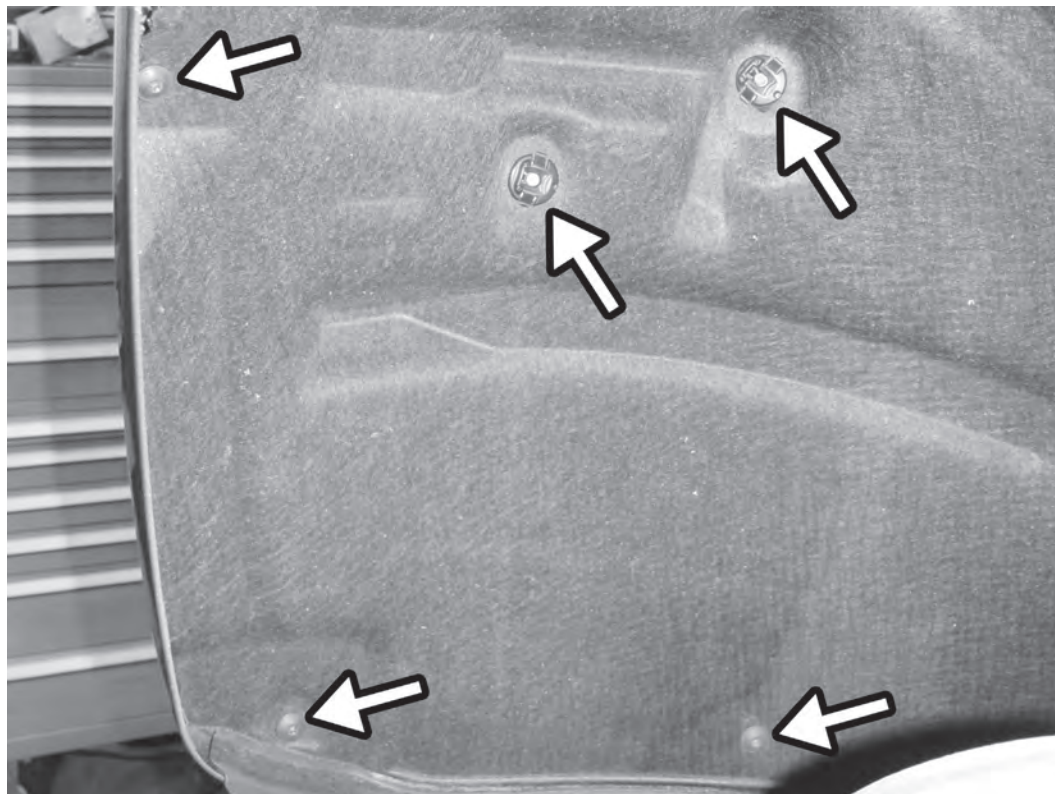

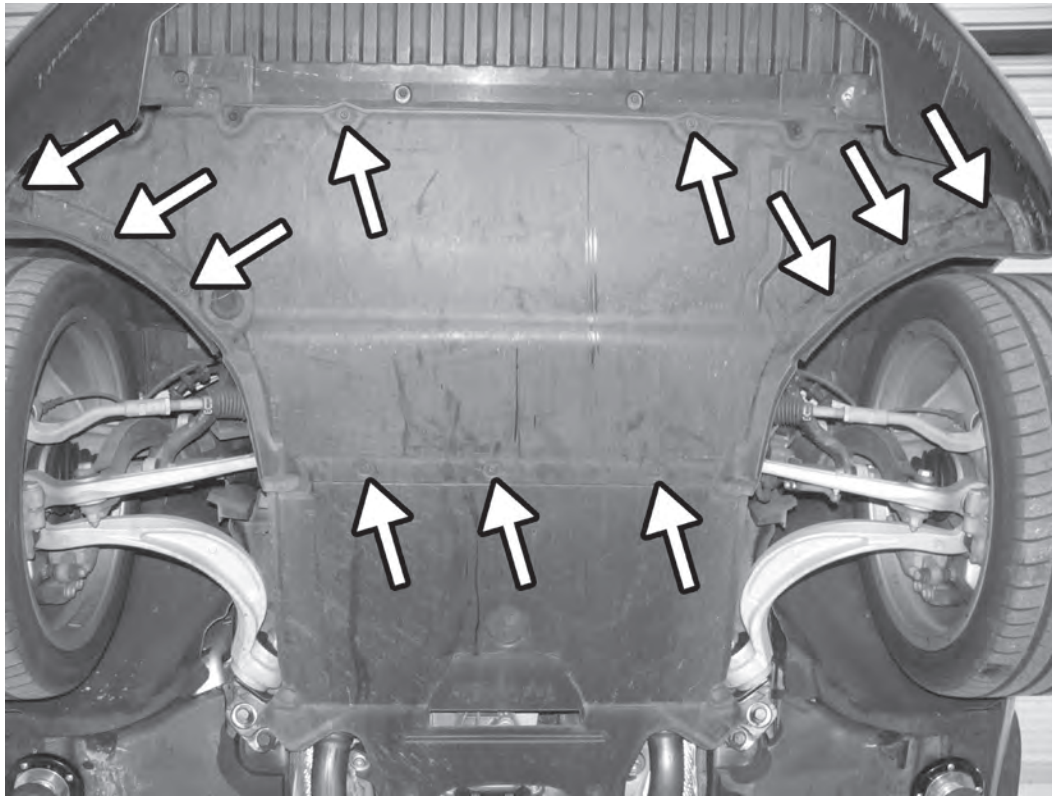

3) Remove the 11 quarter turn fasteners from belly pan with a screwdriver and remove the belly pan.

4) Remove the 4 T30 Torx screws from bottom of bumper cover.

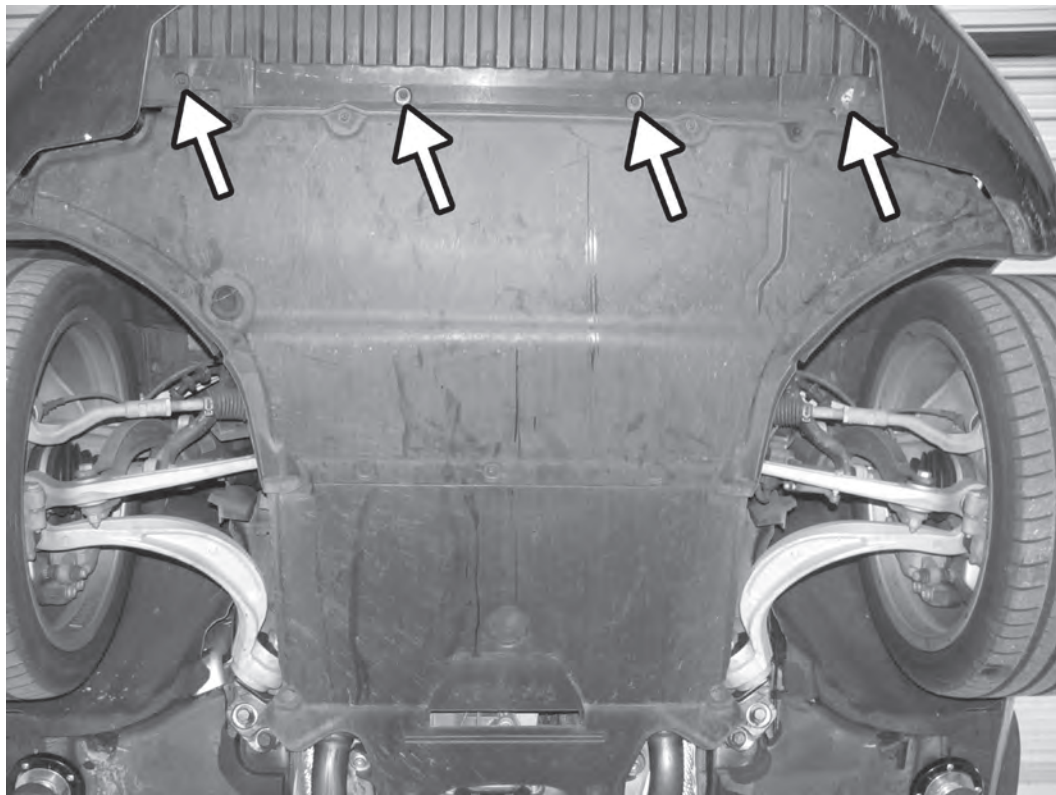

APR, LLC

4800 US HWY 280 West Opelika, AL 36801

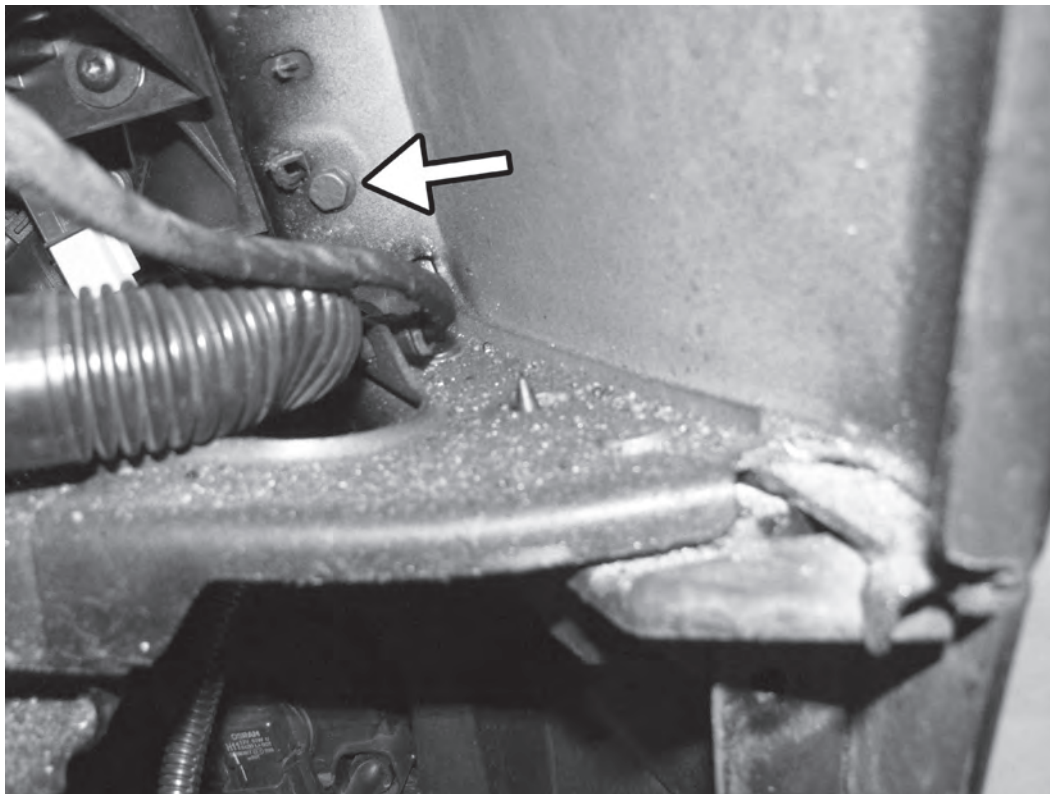

5) Pull back fender liner and remove the 10mm bolt from bumper cover. Repeat on both sides.

6) Remove 4 T30 Torx screws from upper bumper trim cover and remove the cover.

The B8.5 cars use a push pin type fastener. Push the center of the fastener in, and then lift out the fastener from the outer ring.

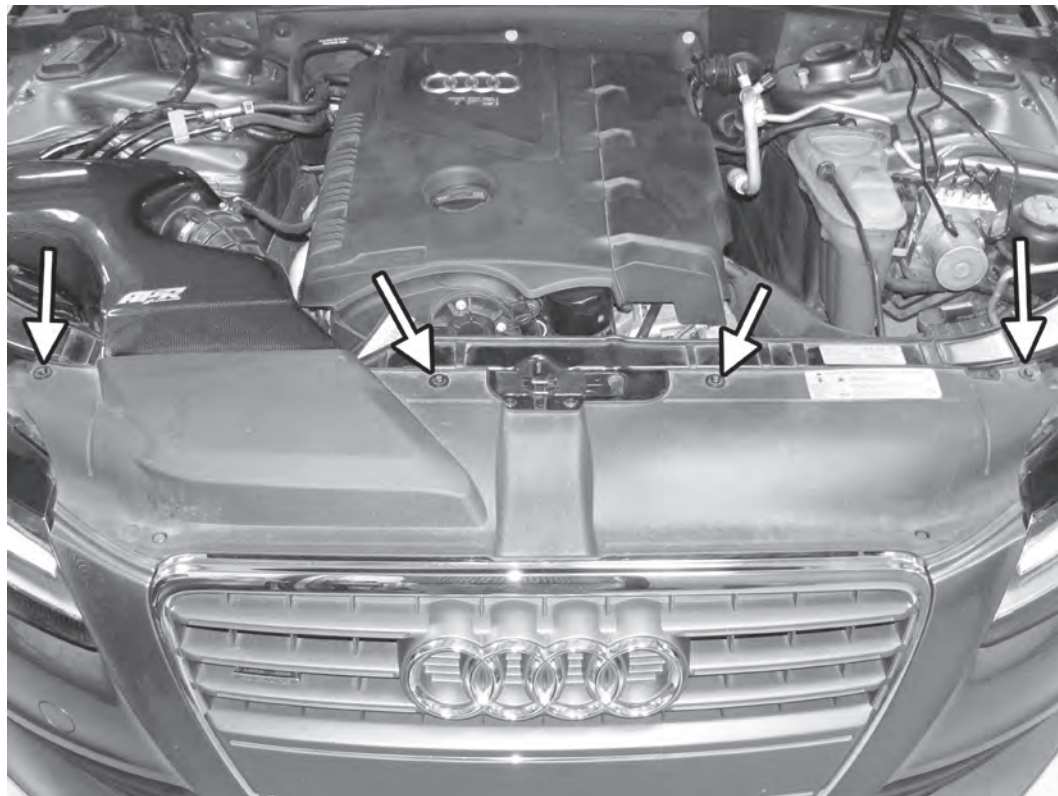



7) Remove 2 T25 Torx screws from top of bumper cover.

8) Carefully pop the upper corner of bumper cover out. Repeat on opposite side.



APR, LLC

4800 US HWY 280 West Opelika, AL 36801

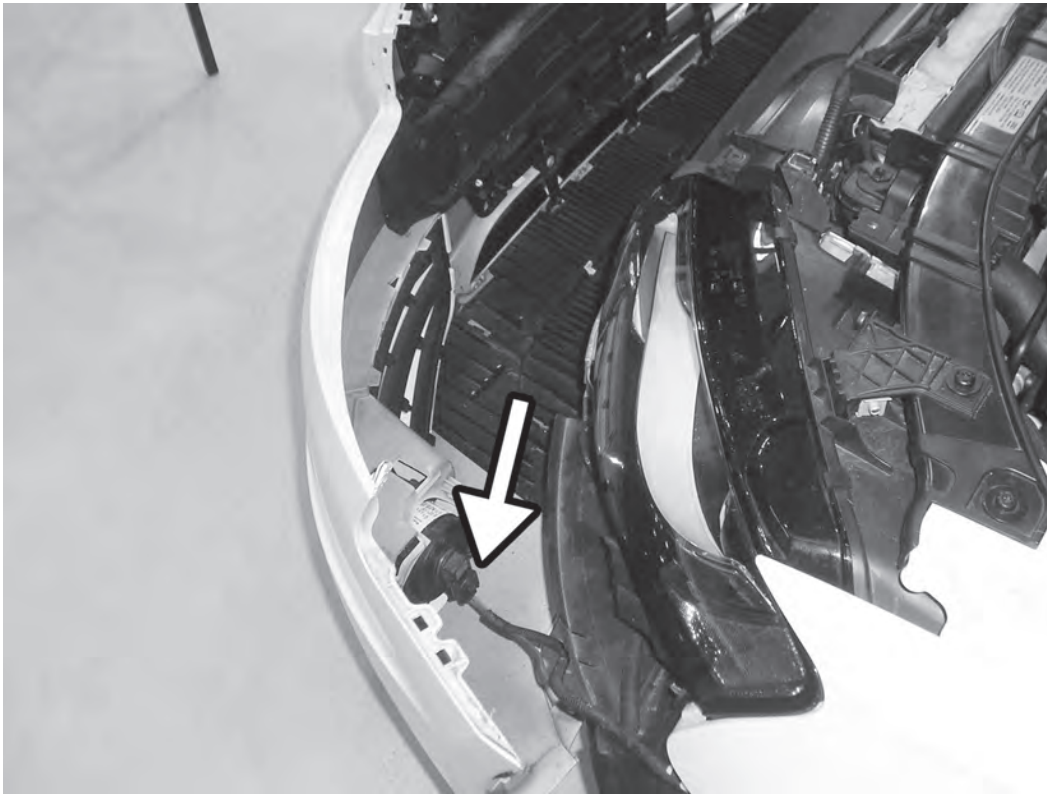

9) Carefully pull bumper cover forward and disconnect left and right fog light harness. Remove the HomeLink module from behind the center grille. Remove the bumper cover.

10) Disconnect the electrical connectors to both horns on either side of the bumper beam. Disconnect the electrical connector to the outside air temperature sensor. Remove all clips that hold the wiring harnesses for these connectors to the bumper beam.

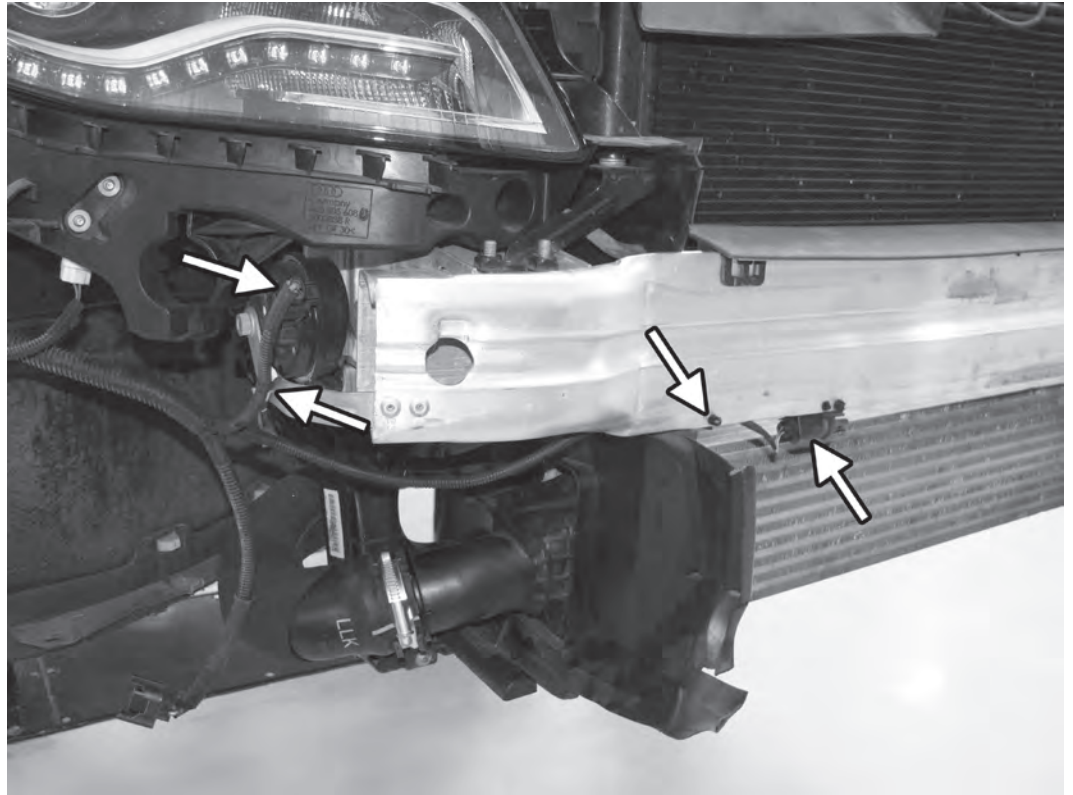

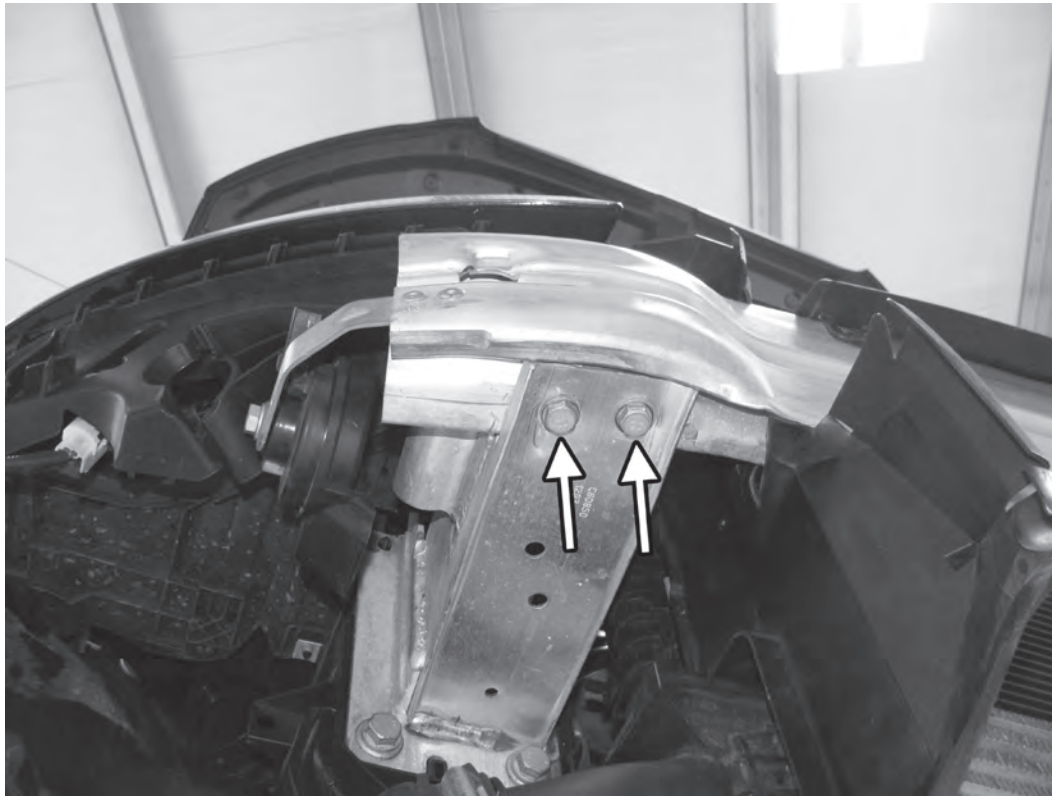

11) Remove the four 13mm bolts that hold the bumper beam to the bumper beam supports.

12) Use a large flat screwdriver or pry bar to separate the top of the bumper beam supports from the bumper beam. Rock the bumper beam forward and remove it from the car.



APR, LLC

4800 US HWY 280 West Opelika, AL 36801

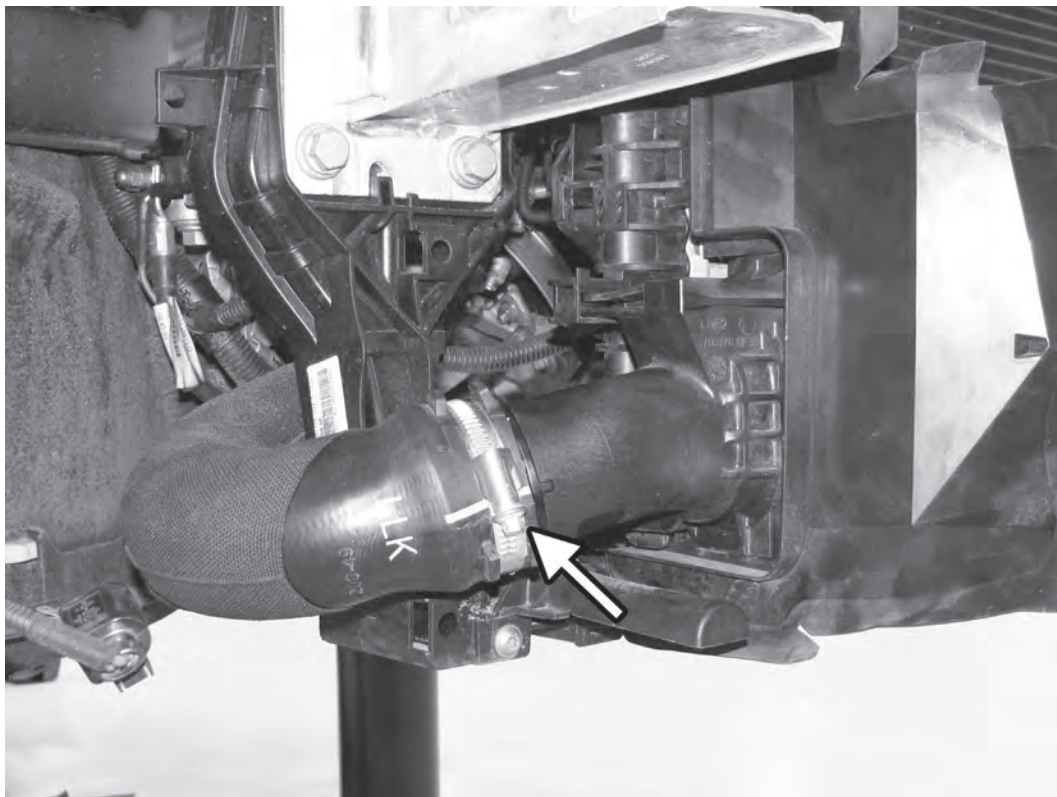

13) Using a large flat screwdriver or 7mm socket, loosen the hose clamps from the intercooler hoses at the intercooler. Disconnect the hoses from the stock intercooler.

14) Remove the one T30 screw that holds the left side of the stock intercooler to the factory core support.

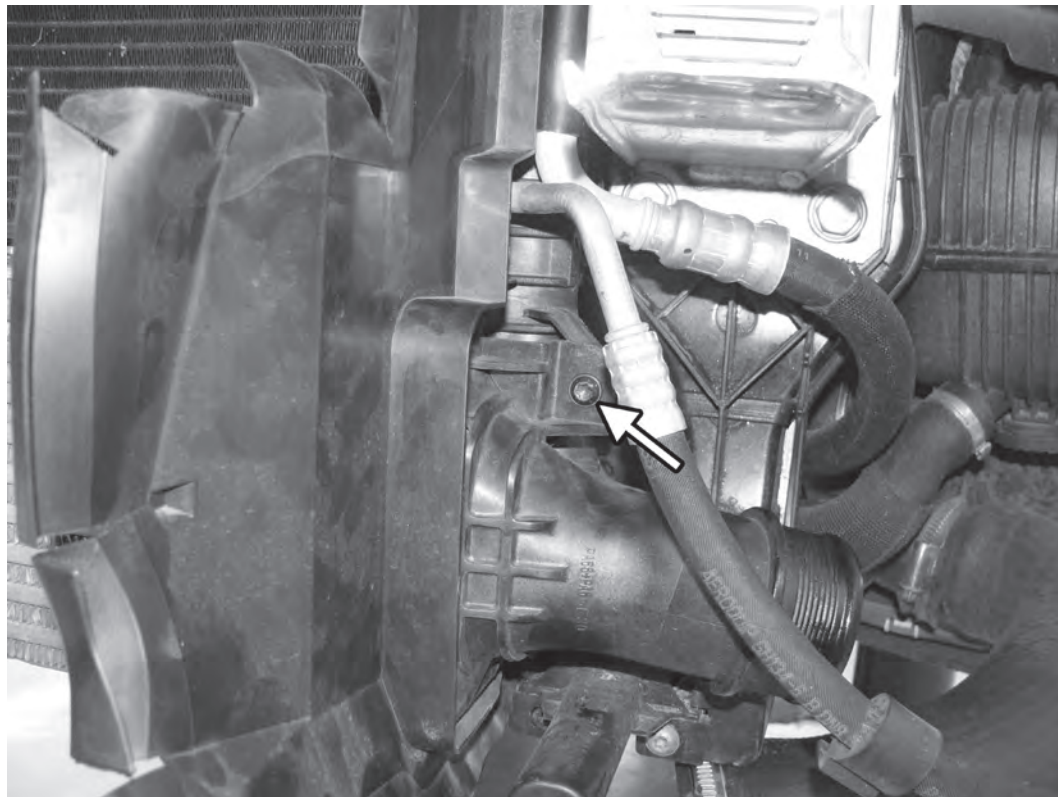

APR, LLC

4800 US HWY 280 West Opelika, AL 36801

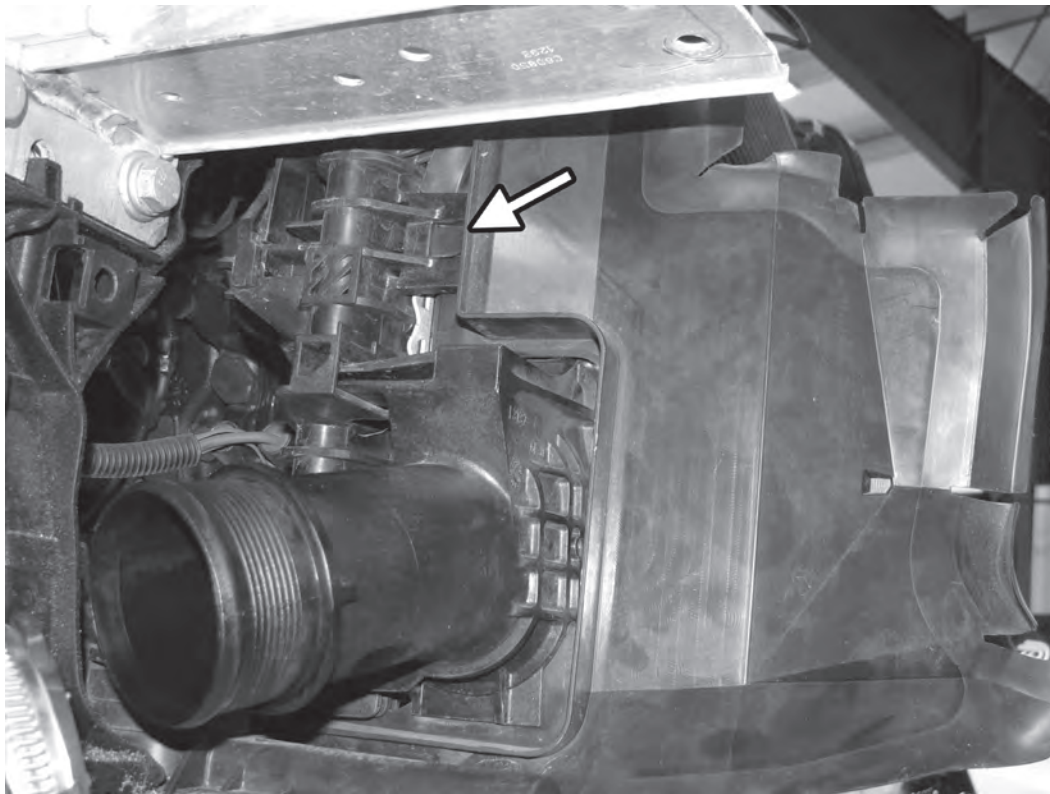

15) Press the tab on the right radiator air guide and pull the lower part of the guide off the stock intercooler and away from the front of the car.

16) Press down on the tab on the right side of the intercooler that holds it to the stock radiator, and then pull the intercooler towards the front of the car.

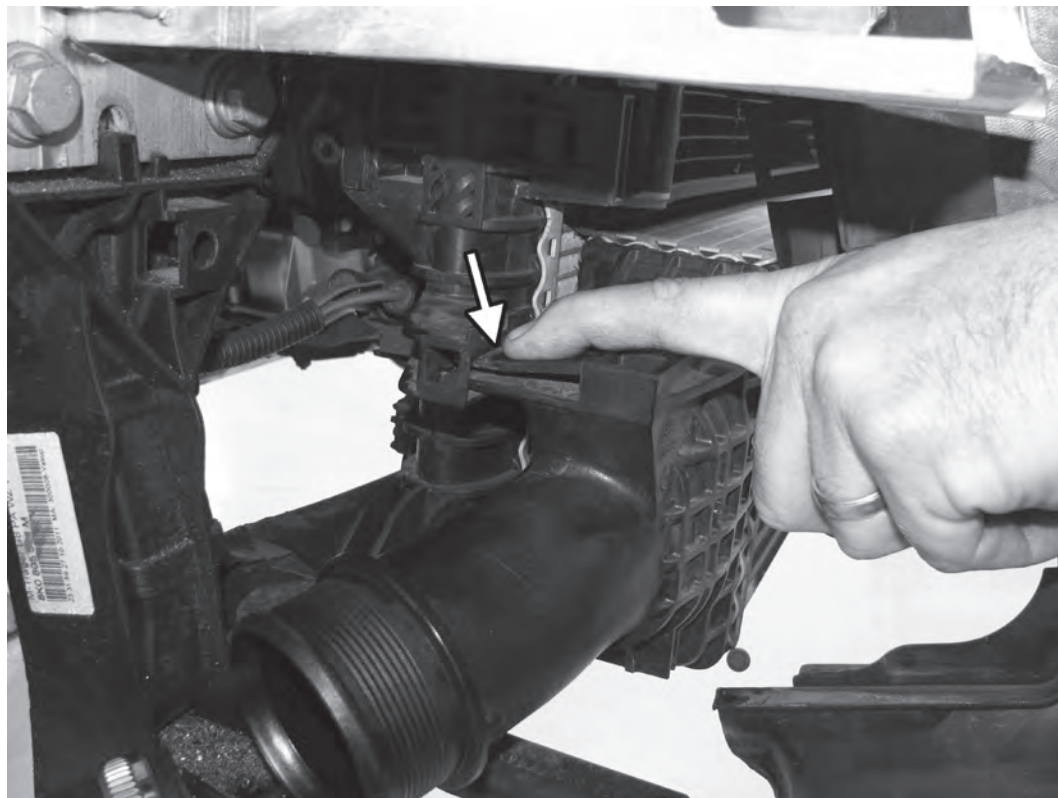

APR, LLC

4800 US HWY 280 West Opelika, AL 36801

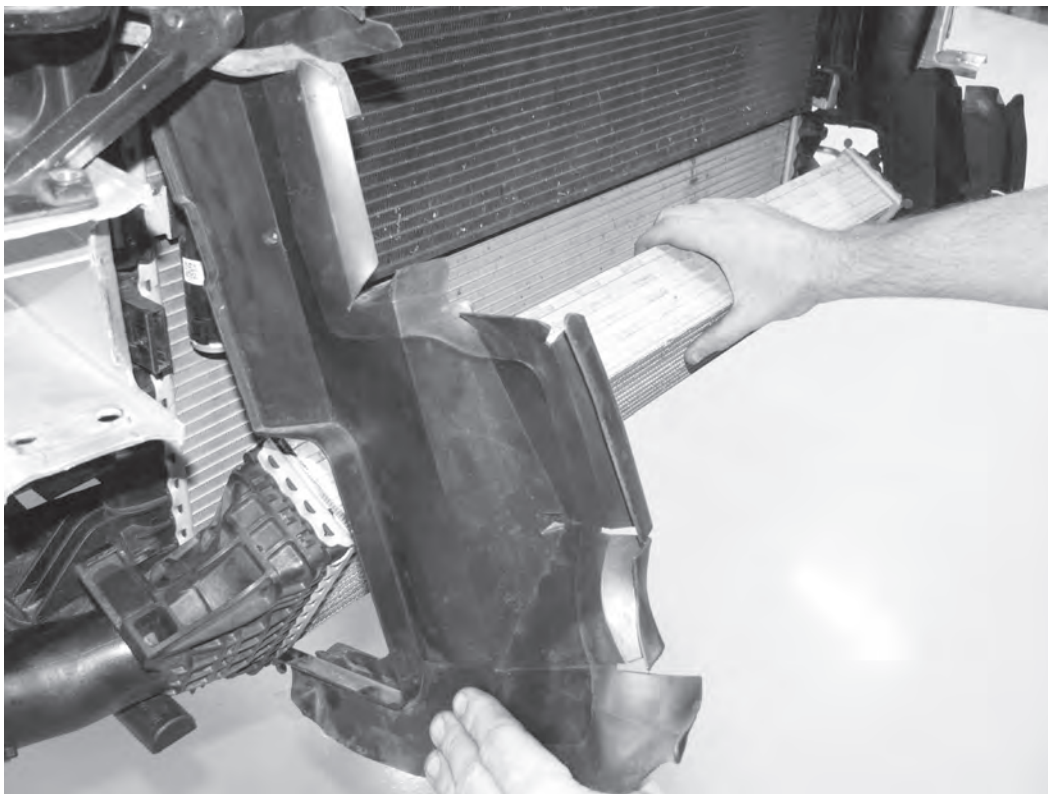

17) Pulling the right air guide out of the way, rotate the top of the intercooler away from the car, and then pull the intercooler away from the car, beginning with the right side. Maneuver the left side of the intercooler through the left air guide, and remove the intercooler from the car.

If the vehicle is equipped with ADS and has a steering cooler, refer to the APR ADS Cooler Installation Manual.

18) Install the two supplied brackets to the APR intercooler using the four supplied 13mm bolts. Be sure the four unused mounting holes on the top of the brackets are facing the front of the intercooler.

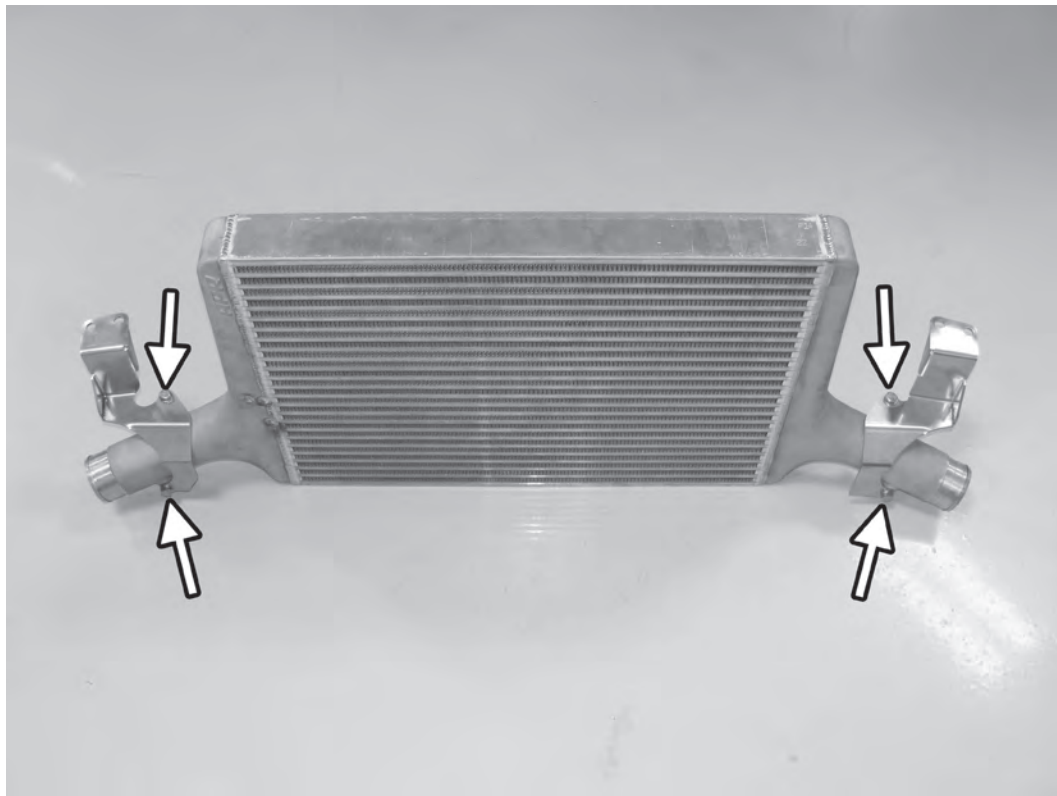

APR, LLC

4800 US HWY 280 West Opelika, AL 36801

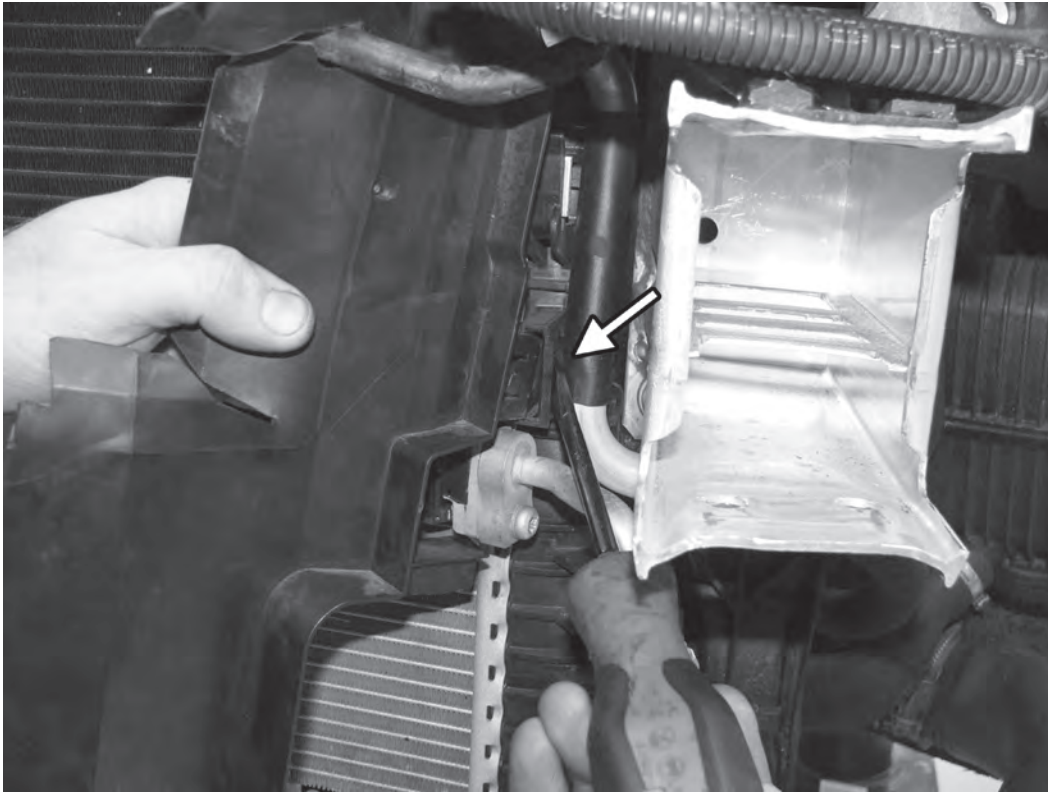

19) Using a large flat screwdriver, press the tab on the left radiator air guide and pull the lower part of the guide away from the front of the car.

20) With an assistant, maneuver the APR intercooler onto the car. Place the left side first, being sure the intercooler goes behind the left air guide, and that the air conditioning hose on the left side sits in the notch on the front side of the left APR intercooler bracket.

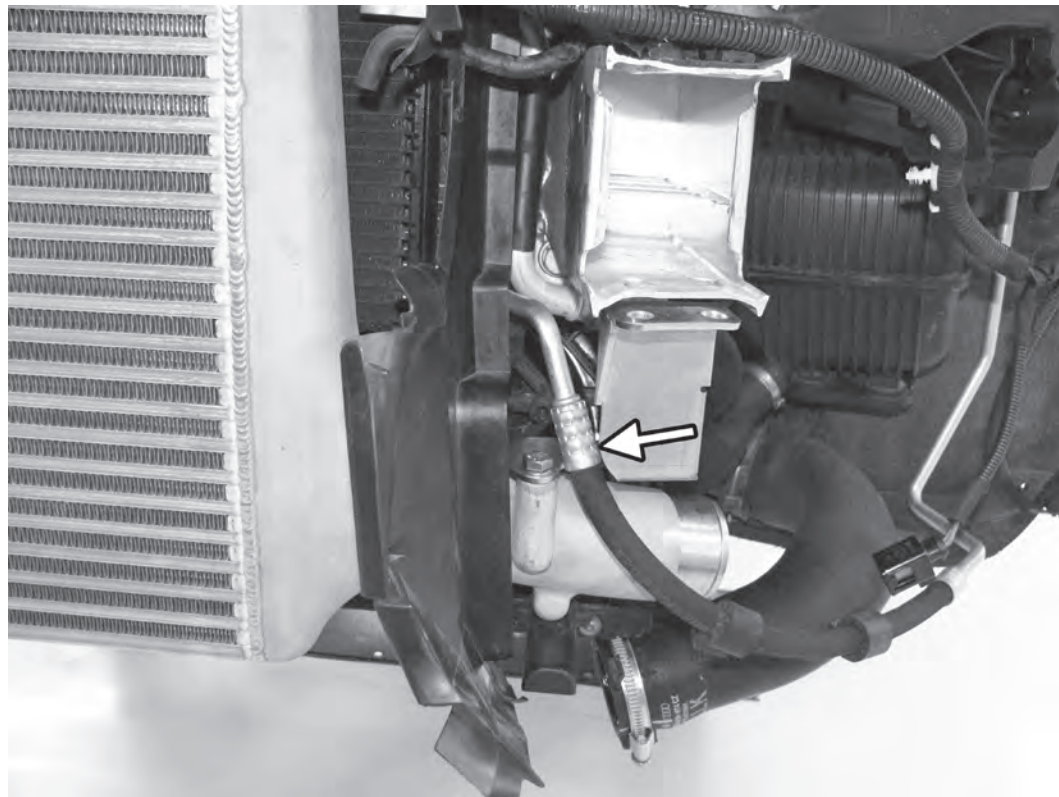

APR, LLC

4800 US HWY 280 West Opelika, AL 36801

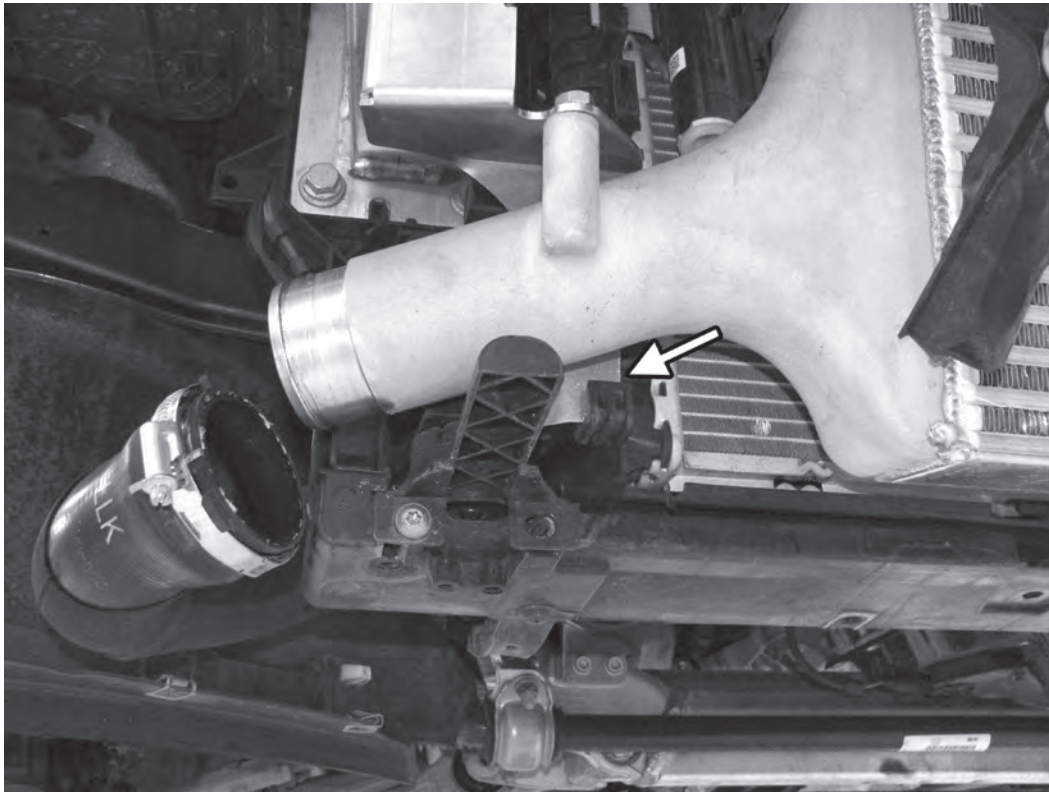

21) Bring the right side of the APR intercooler back towards the factory mounting points. Be sure to lower the bottom of both APR brackets into the slots on the bottom of the factory radiator, where the stock intercooler used to sit.

22) While holding the intercooler in place, have the assistant place the stock bumper beam back on the car.

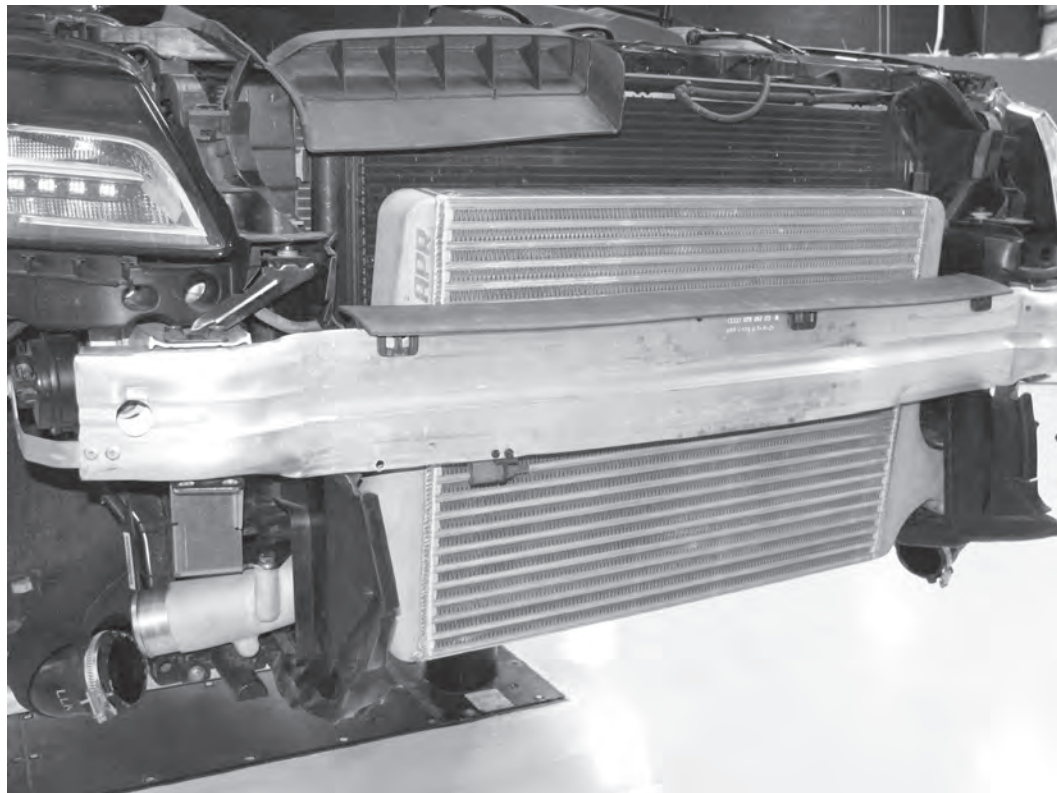

APR, LLC

4800 US HWY 280 West Opelika, AL 36801

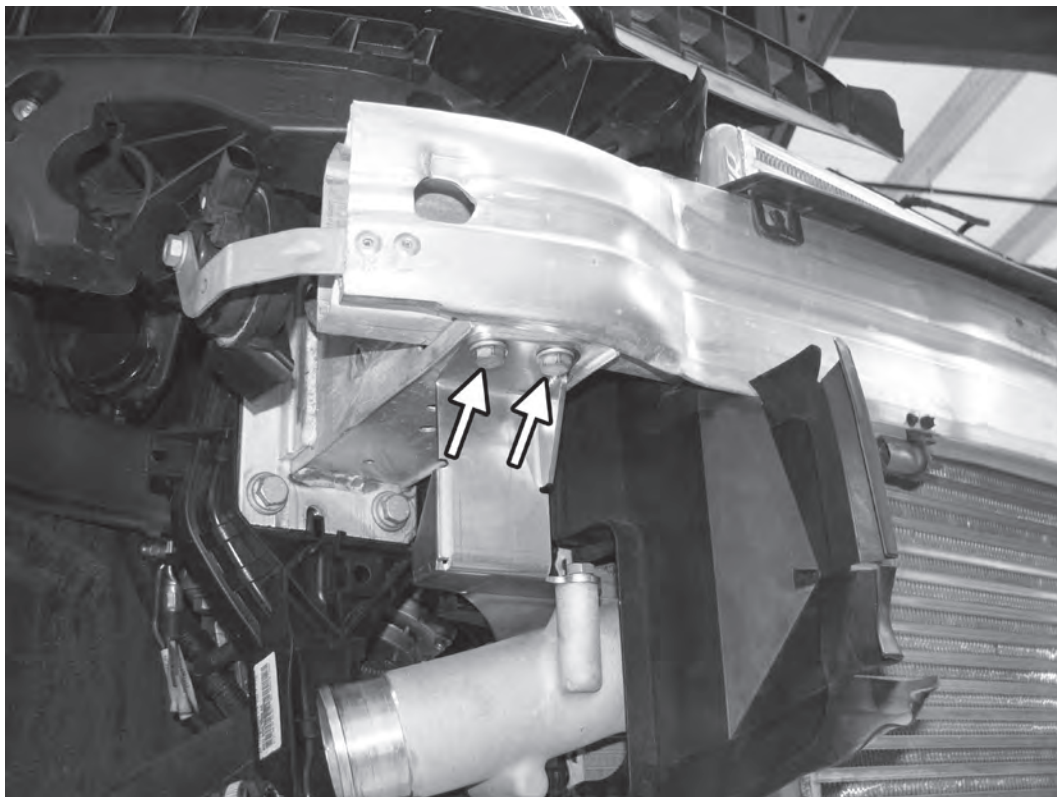

23) Reinstall the four 13mm factory bumper beam bolts, running the bolts first through the APR intercooler brackets and then through the bumper beam.

Make sure the air conditioner hose on the left side of the car is not touching the APR bracket.

24) Reinstall the factory intercooler hoses, and secure them with the factory hose clamps with either a large flat screwdriver or a 7mm socket.

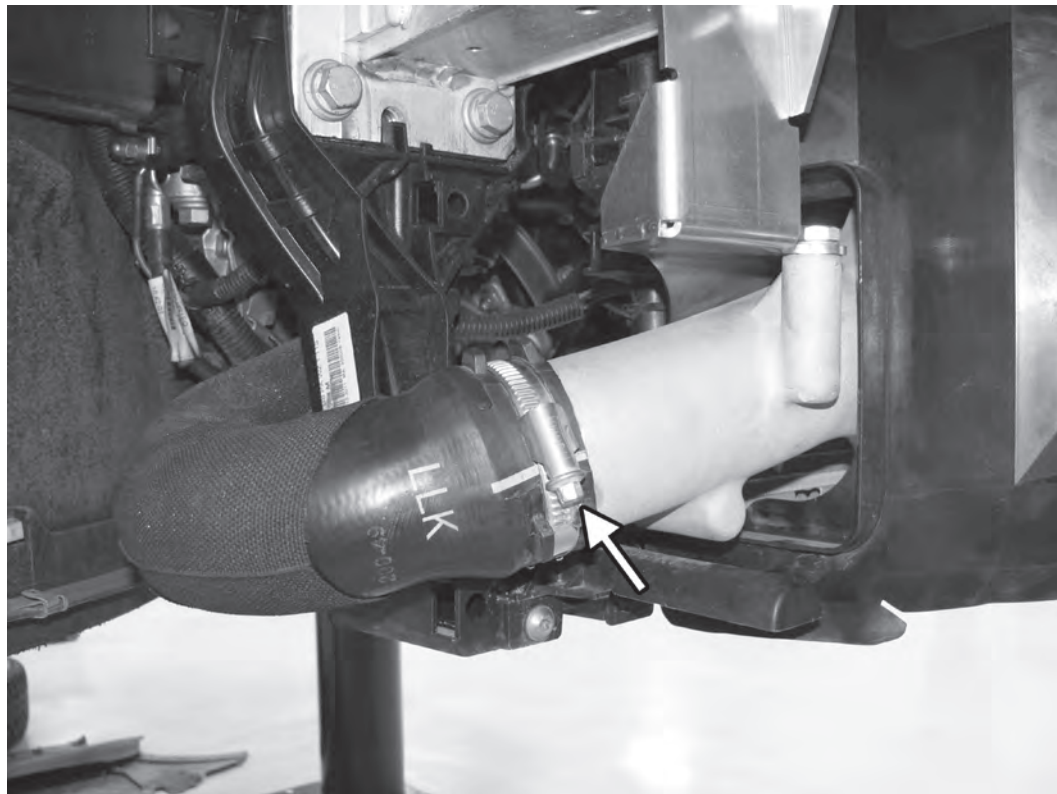

APR, LLC

4800 US HWY 280 West Opelika, AL 36801

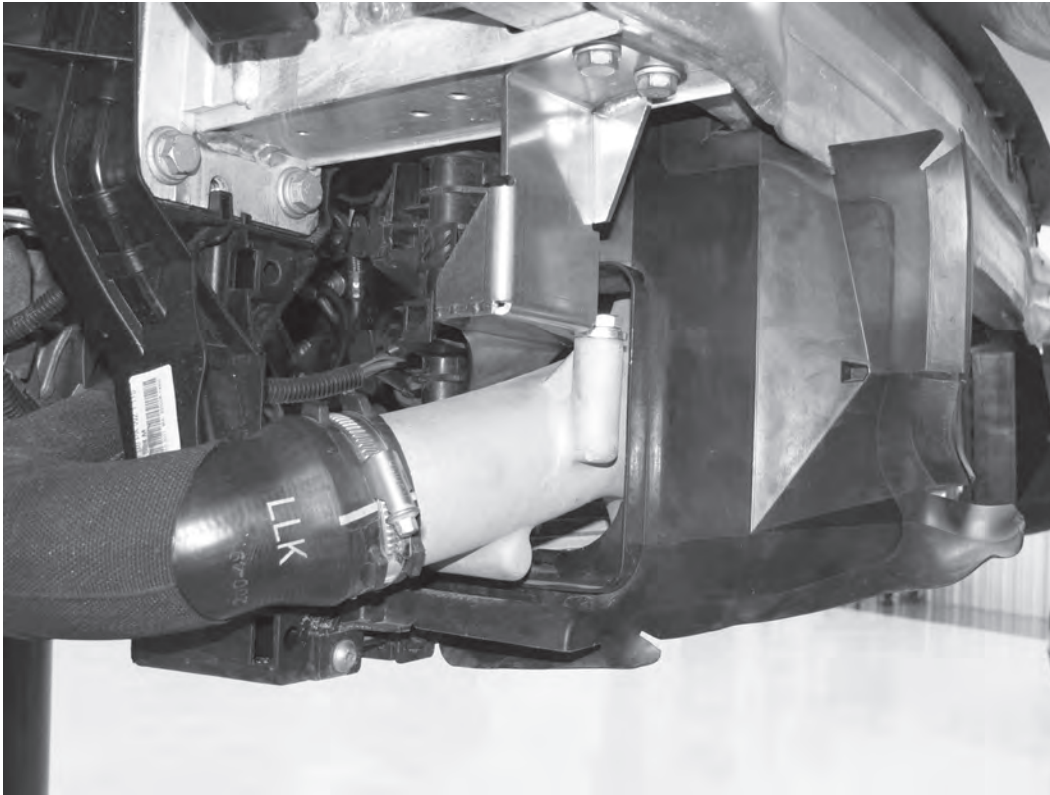

25) Push both the left and right air guides back to their original location, making sure they snap into their mounting points.

26) Reconnect the electrical connectors to both horns and the outside air temperature sensor. Be sure to remount the clips that held the wiring harness to the bumper beam.

If the vehicle is equipped with ADS and has a steering cooler, refer to the APR ADS Cooler Installation Manual.

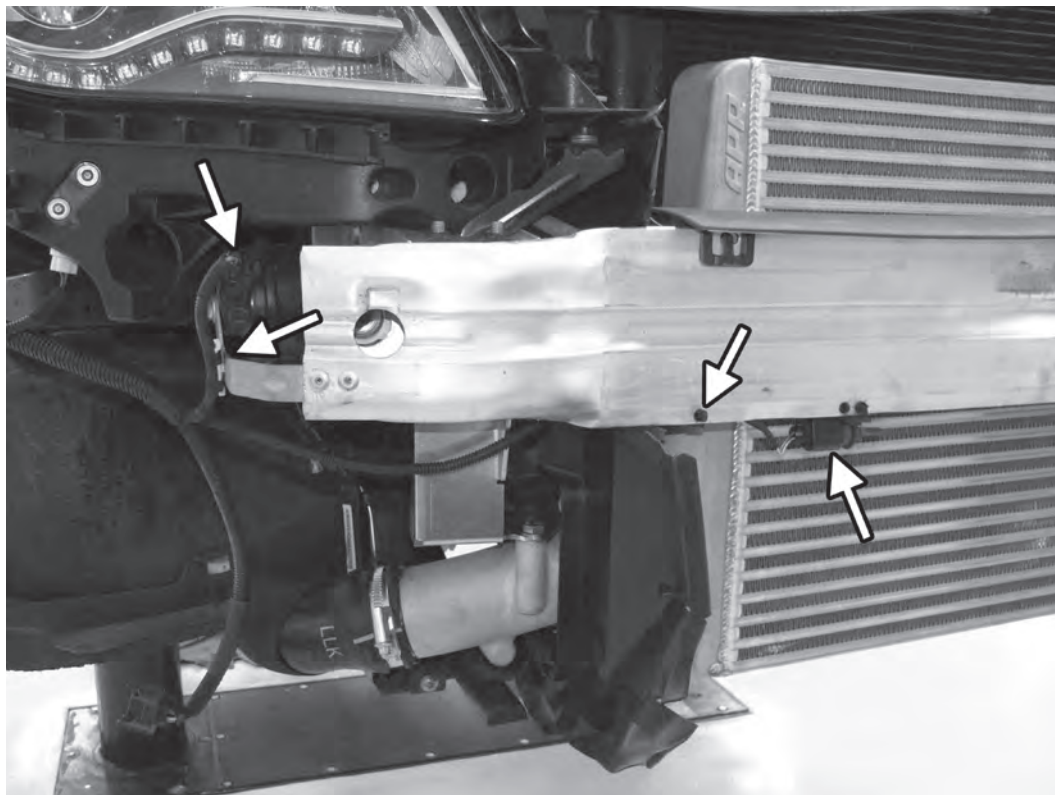

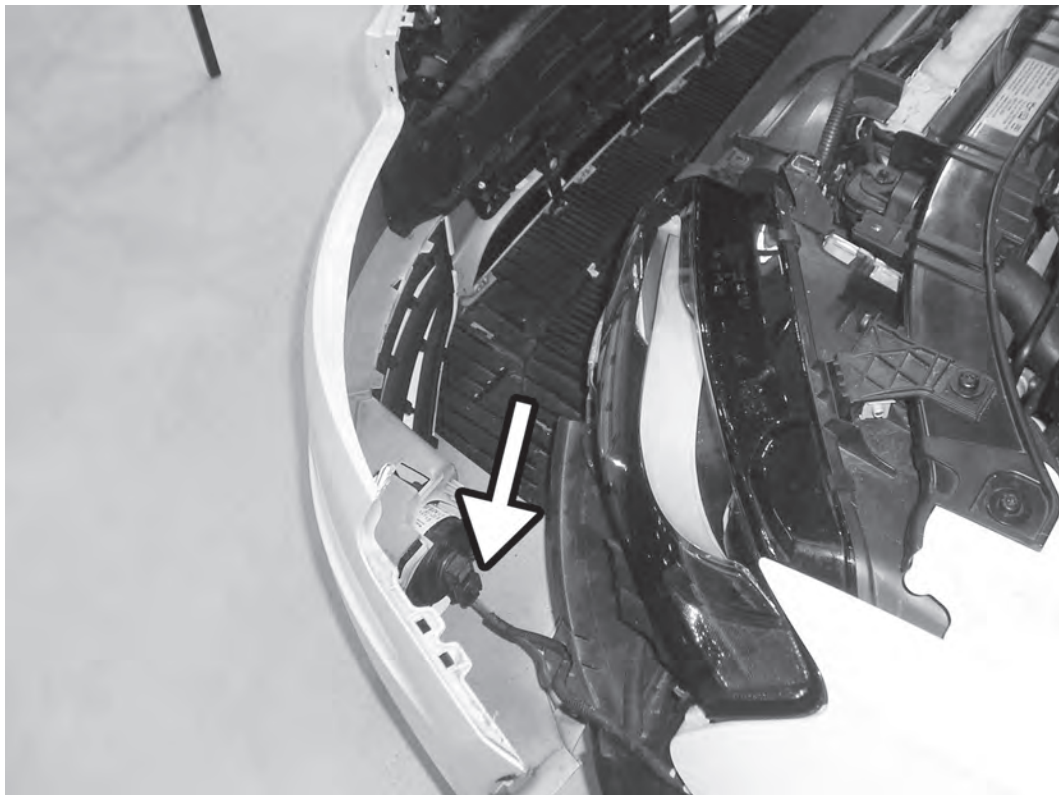

27) Reinstall bumper cover, being sure to reconnect the left and right fog light harnesses and reinstall the HomeLink module.

28) Reinstall 2 T25 Torx screws from top of bumper cover.



APR, LLC

4800 US HWY 280 West Opelika, AL 36801

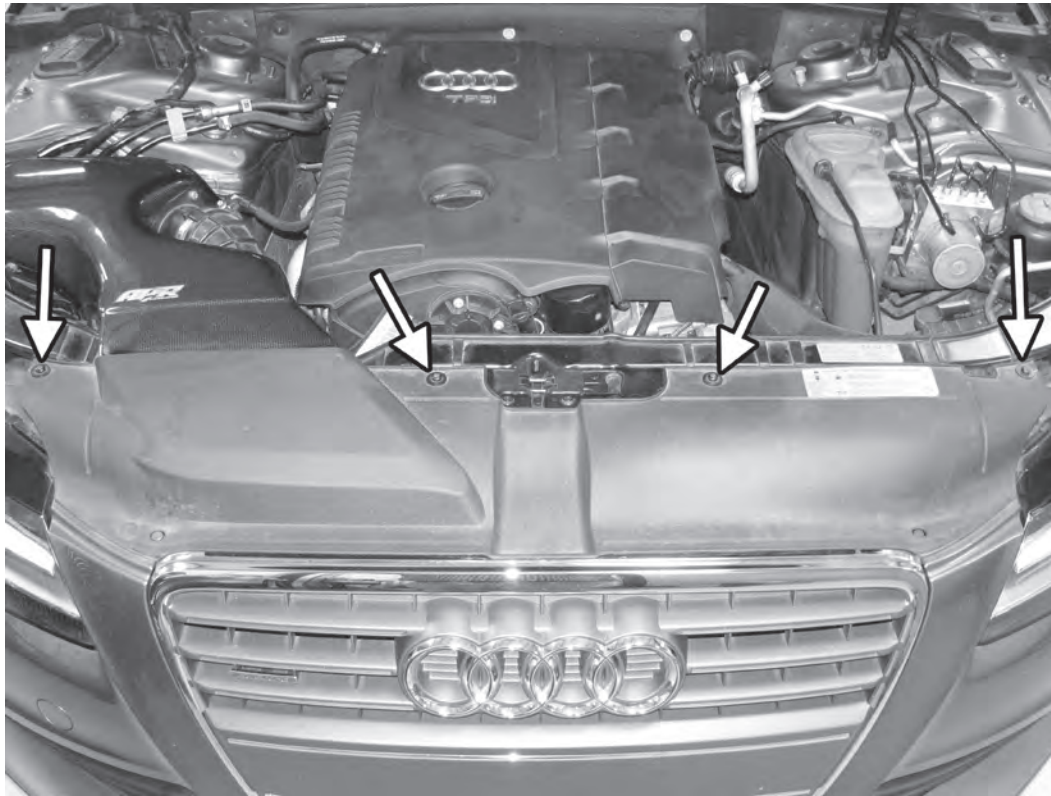

29) Reinstall upper bumper trim and then fasten with the 4 T30 Torx screws on the B8. On the B8.5 cars, reinstall the four push pin type fasteners. With the center pin removed, install the outer ring. Then press the center pin in place.

30) Pull back fender liners and re-install bolt the 10mm bolts to bumper cover.

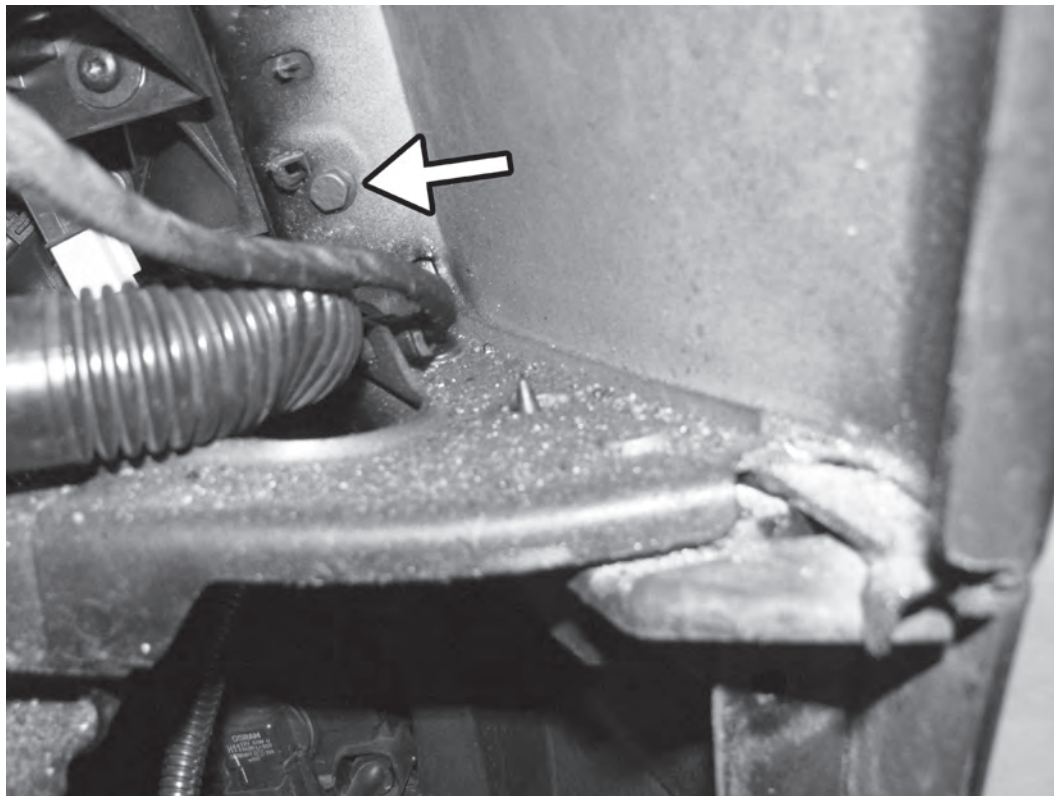

APR, LLC

4800 US HWY 280 West Opelika, AL 36801

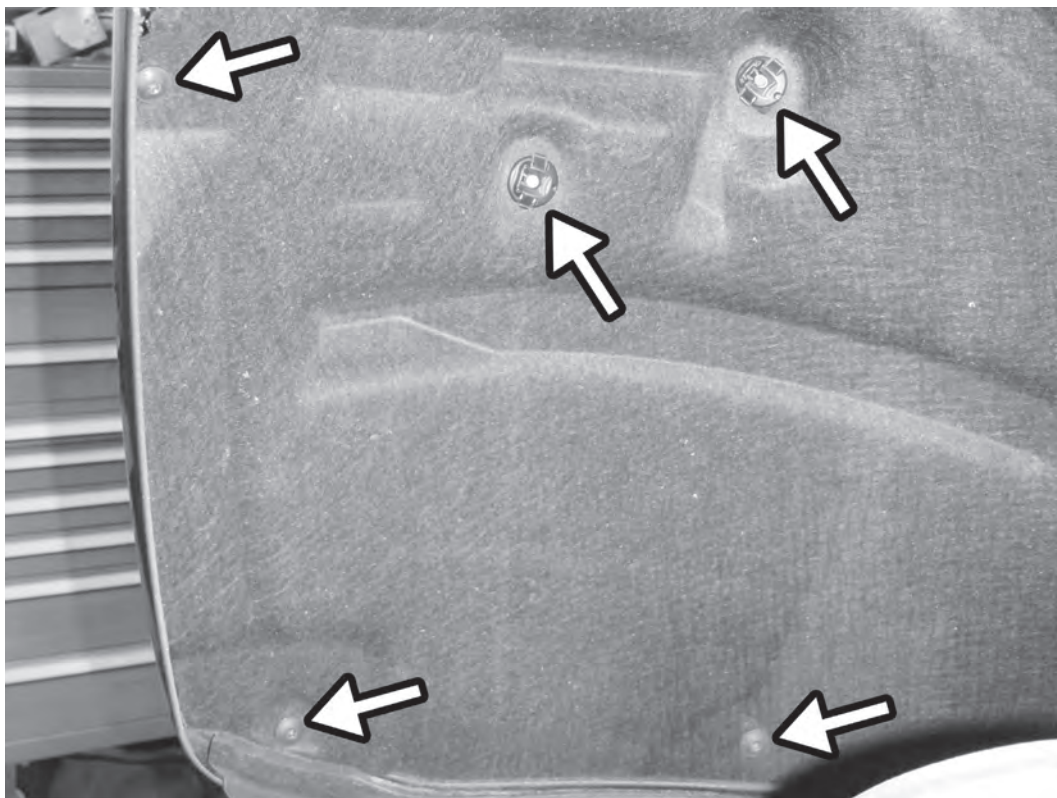

31) Reinstall 3 T25 Torx screws from fender well liner and reinstall the plastic clips.

32) Reinstall 4 T30 screws from bottom of bumper cover.

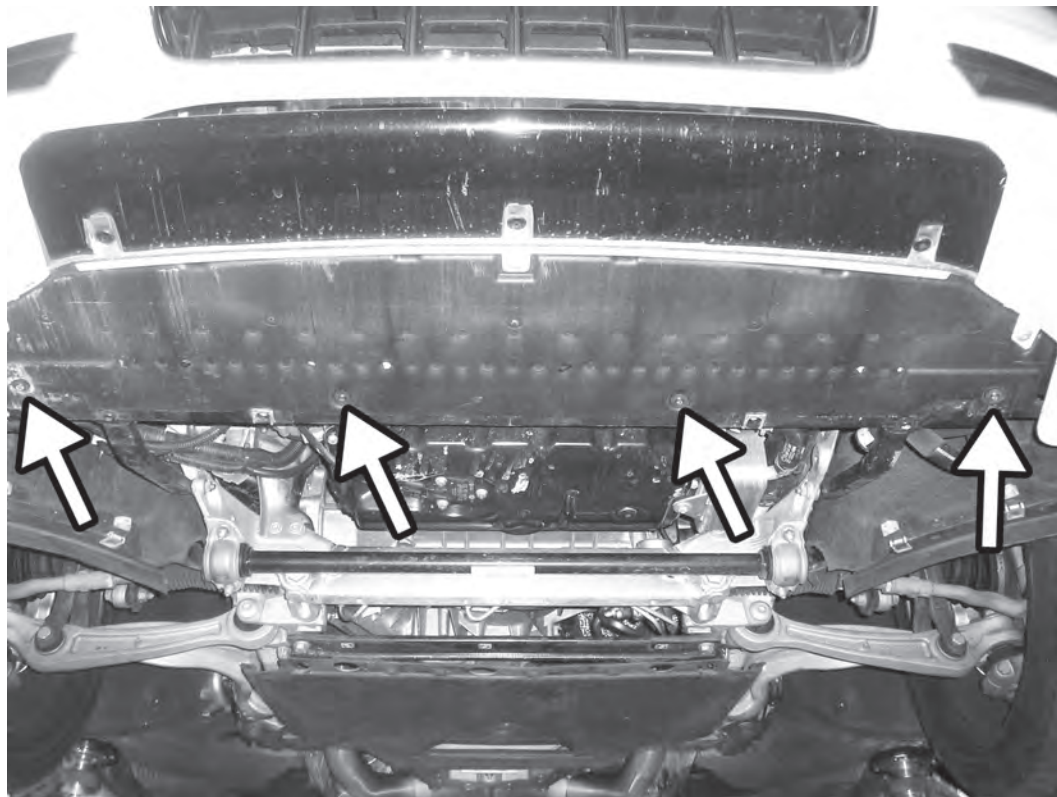

APR, LLC

4800 US HWY 280 West Opelika, AL 36801

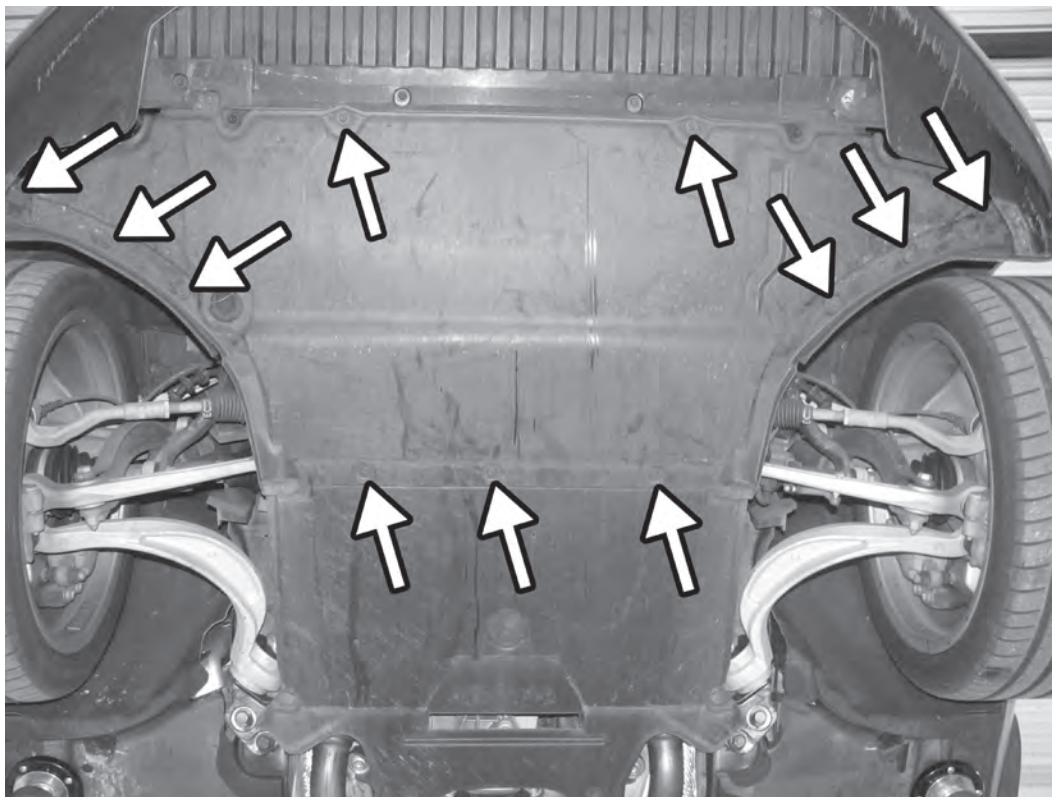

33) Reinstall the belly pan and the 11 quarter turn fasteners with a screwdriver.

34) Reinstall both front wheels. Remove vehicle from lift (or jack stands). Torque the wheel bolts to 120NM (90lb-ft). Enjoy!.



APR, LLC

4800 US HWY 280 West Opelika, AL 36801

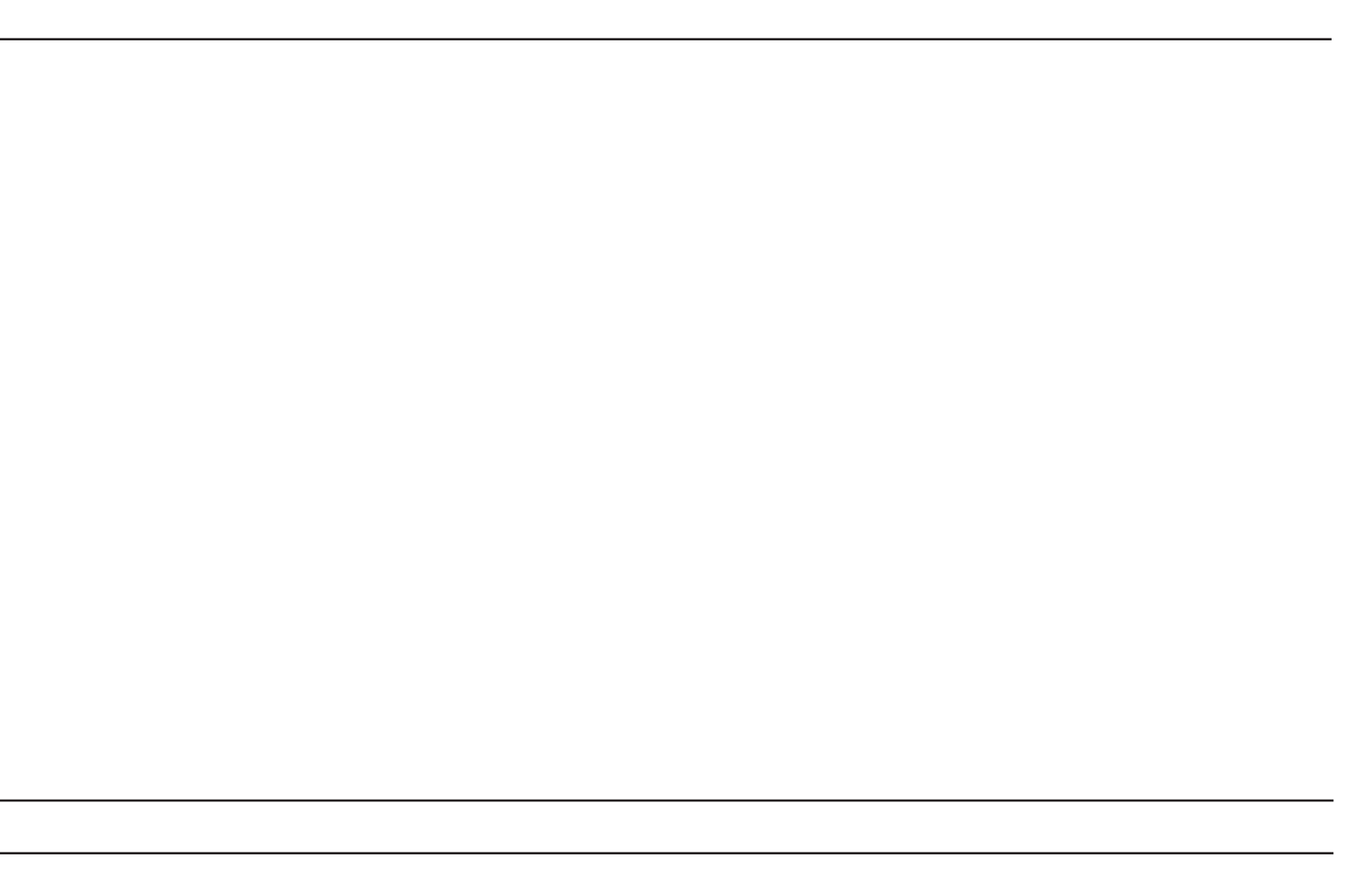

#TL10039



B8/B8.2 AA/2 INTERCOOLER SYSTEM
INSTALLATION INSTRUCTIONS

APR