

Installation Instructions

1935 to 1940 Ford Crossmember Kit

Please read these instructions completely **BEFORE** starting your installation.
Remember the basic rule for a successful installation:
Measure Twice, Weld Once.

1. Start by supporting the car on 4 jack stands. The car should be sitting on approximately the same angle as it does on the ground, or slightly lower in front.

2. Remove all the old front suspension components. Note that on the underside of the frame are the two rubber axle snubbers (or the holes for them, if they are missing) directly above the axle. Mark them for later reference.

3. We would recommend that at this point, you tack weld or clamp a temporary brace across the frame rails in front of the old crossmember as shown in Figure 1. This helps to maintain the rail dimension after the old crossmember is removed.

4. Remove the old crossmember. The front gussets, which are also the radiator mounts, may be trimmed in the frame, or removed to be cut and then reinstalled. Also, remove the old steering box mount.

5. Now it's time to recondition your frame rails. Your frame is two layers thick in the front area. During the past 60 some years, rust forms between the layers of the frame rail flanges and swells, causing them to separate. This causes the rail flanges to actually open up, as in Figure 2A. Your rails will probably look similar to this. It is necessary to squeeze the two layers back together, using a vice-grips or hammer and block. Then, using a large C-clamp, bend both flanges back together so the rail is square again. (See Figure 2B.) It does not need to be perfect for the entire length, but it should be close in the areas where the new crossmember and spring towers mount. The better you can make the rails in this step, the easier it will be to weld in the new components. Also, grind off and weld in the rivets on the top of the frame rails.

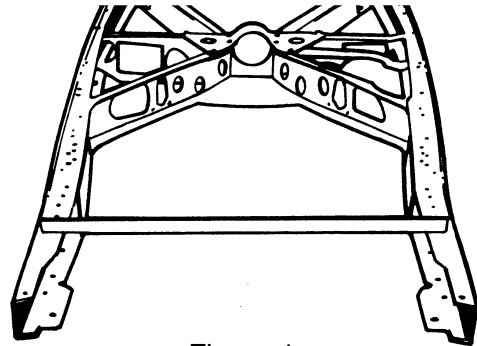

Figure 1

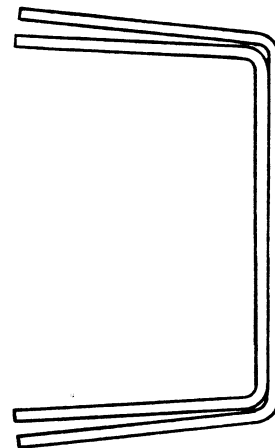

Figure 2A

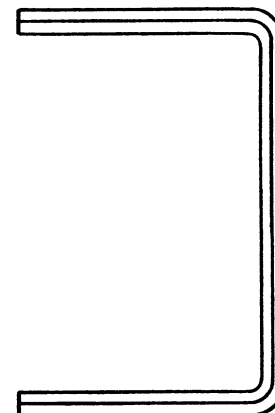

Figure 2B

Installation Instructions

1935 to 1940 Ford Crossmember Kit

6. The next step is to box the rails. The edges of two layers of metal probably don't line up very well on the frame flanges. Grind them down so they are flush and straight, and the boxing plates fit tight against them. (If the boxing plates fall into the frame rails, the rails are still too wide. Repeat step 5.) Caution: Do not grind too much material off the flanges. The finished boxed rails should end up being 2-5/8 inches wide in the new crossmember area. The rest of the rail is not as critical. See Figure 3.

7. Remember that rubber snubber hole from Step 2? Use the center of that hole to scribe a line around the frame rails. This is the axle centerline. Note that on some models, especially '37 to '40 Fords, that the axle was actually back from the snubbers up to 1". Check that your wheelbase (the scribed axle centerline) is 112 inches. If not, move the scribed line accordingly. Many times, the snubbers were too far forward. As a final check, just to be safe, you could temporarily place a fender on the frame and stand a tire & wheel in place in the fender, centering the wheel in the fender opening. Slide a bar or broom handle through the wheel center hole. It should fall on your correct axle centerline. Remember the basic rule – measure twice, weld once.

8. If you are using stock components, skip over this step. If you purchased a complete I.F.S. Package from *HEIDTS*, it was supplied with Full Lower A-Arms. Begin here by installing the Spacers onto the crossmember. The holes where the lower control arms attach to the Crossmember must be enlarged to 5/8". Mount the Crossmember Spacers and the Rear Spacers which were supplied with the Lower Control Arms as shown in Figure 5 onto the Crossmember using the supplied Inner Bushing Bolts, Nuts and a temporary spacer under the Nuts. DO NOT use the A-Arms for this operation as the welding heat will melt the rubber bushings. Tighten the Bolts and Nuts tight. Weld the Rear Spacers to the Crossmember all around. Weld the Crossmember Spacers as far as possible inside the crossmember on both ends. Position the Gussets horizontally, not vertically, against the Rear Spacers and the back of the Crossmember. Weld Gussets to Spacers and Crossmember. When it cools, remove the bolt.

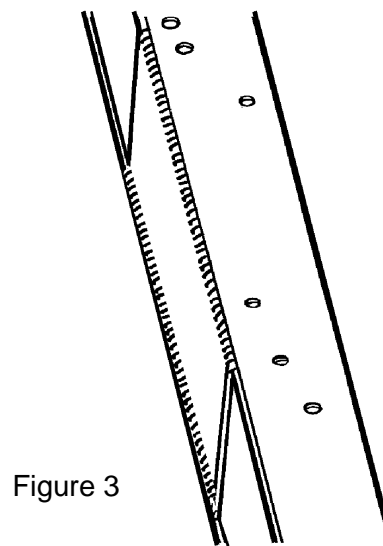

Figure 3

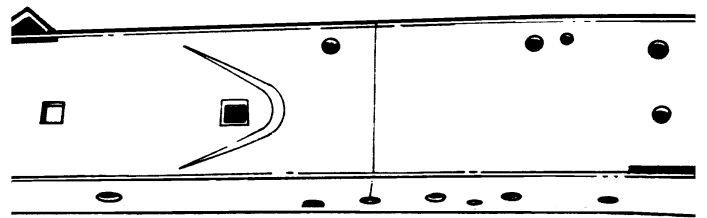

Figure 4

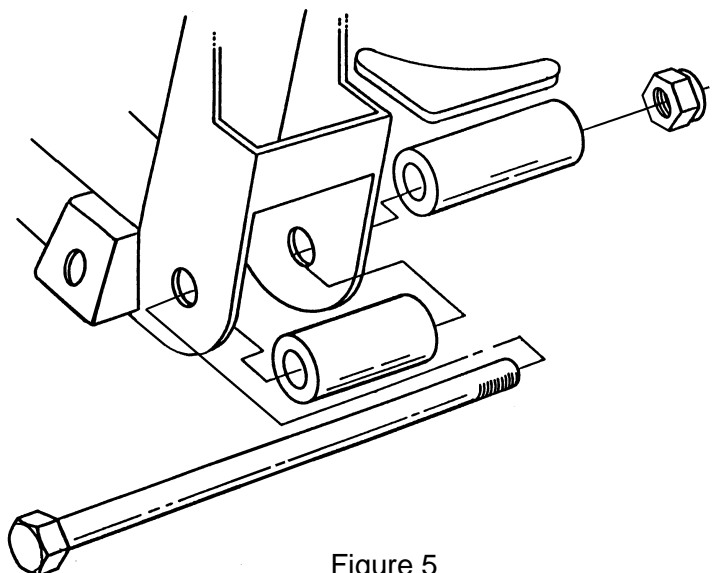

Figure 5

Installation Instructions

1935 to 1940 Ford Crossmember Kit

9. Now it is time to start fitting and installing the new crossmember in the frame. Slip the crossmember up into the frame, center it on the scribed axle center line (Figure 6). If it does not fit, check that your frame is the correct width. It should be 30-5/16" wide at the axle center line (scribed line). If it is that dimension, then grind the sides of the crossmember until you can get the crossmember in place, as shown. Tack weld in place, check location, then weld in place, welding all around both ends, top, sides, and bottom. If you installed a temporary brace across the rails, you can now remove it.

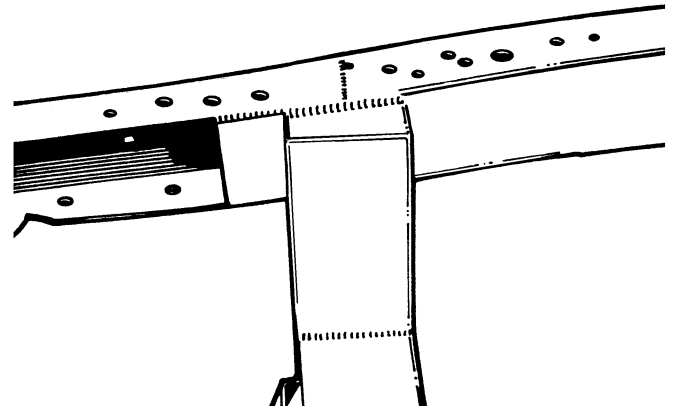
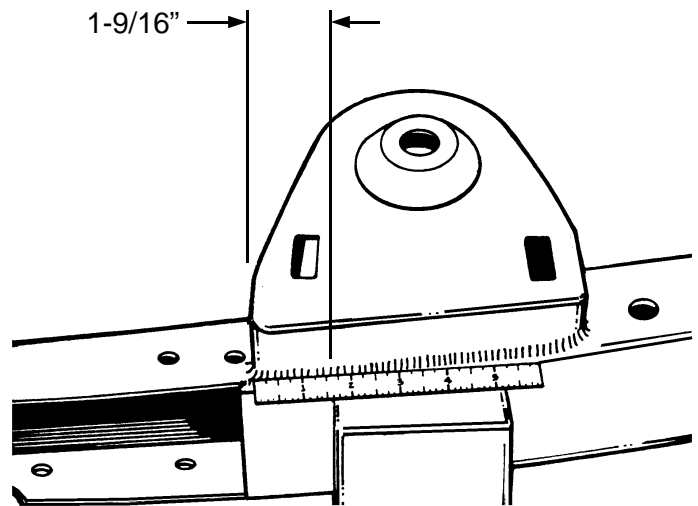

Figure 6

10. Next are the spring towers. They sit on top of the frame rails, and are located as shown in Figure 7, (1-9/16" forward of the crossmember measuring from the front of the crossmember to the front of the spring tower). Clamp in place, double check your dimensions, then weld all around, including the gusset flanges on the sides of the rails. For added strength, you can also weld the inside of the gusset flanges



Front of Frame

Figure 7

If you are using stock components, you will need to install strut rod brackets, purchased separately part no. MP-003. Continue on to Step 11. If not, then you are finished and proceed on to the assembly and alignment of your suspension.

Installation Instructions

1935 to 1940 Ford Crossmember Kit

OPTIONAL STOCK STRUT ROD INSTALLATION

11. If you are using factory lower control arms and strut rods you will continue here. Use the lower control arm and strut rod for locating the rear strut rod supports and gussets. Using a 2 x 4 and a C-clamp, install the control arm as shown in Figure 8.

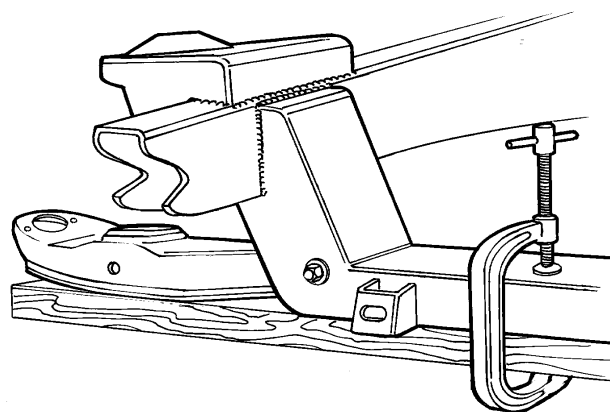
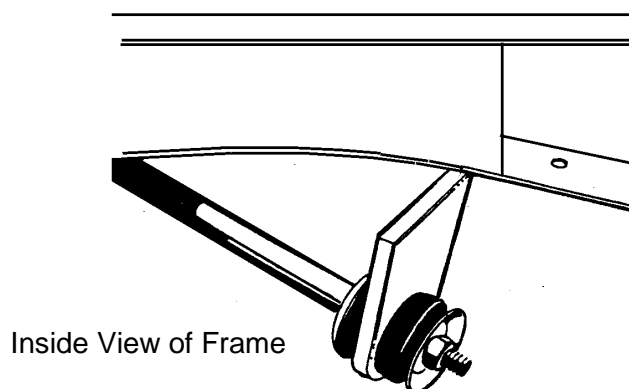

Figure 8

12. Install the strut rod onto the control arm. Now, assemble onto the strut rod the large rubber bushings, including the cupped washers, and the strut mount plate. Be certain to fully tighten the nut on the strut rod to its fully seated position. (See Figure 9) There are two rubber bushing sets available; the standard replacement and the improved set. We recommend the improved set, as it provides more stability to the front suspension. The Pinto and Mustang strut rods are different lengths. We recommend the use of Pinto strut rods, as they are bent less than the Mustang strut rods. You will find that with either strut rod the strut rod plate does not line up with the bottom of the frame rail. The strut rod must be heated in the elbow area and bent outward. The rod is bent outward until the strut mounting plate lines up to the frame rail. You will find that because the Pinto strut rod is initially bent less and requires much less bending. The strut rod will act as an alignment fixture while you tack weld the mount plate in place, then tack weld the gusset in place. Remove the strut rod, bushings, and arm, and finish welding to the frame and each other.



Inside View of Frame

Figure 9

That's all there is to it. Go ahead and finish the assembly of the rest of the suspension components. After the rest of the car is assembled and back on the ground, do your front end alignment as follows:

Caster 1° positive
Camber 1/2° positive
Toe-In 1/8" ± 1/8"

Check the installation after 100 to 200 miles, including the alignment. The springs should have settled down by now, so the lower control arms are parallel to the ground. If the car still sits too high, you may need to change to softer springs, or you can cut up to one coil off the bottom of the springs to get the lower arms horizontal. If it sits too low, stiffer springs or HEIDTS new Spring Spacers are available. If you have any questions during or after the installation, feel free to call us for technical assistance.

