

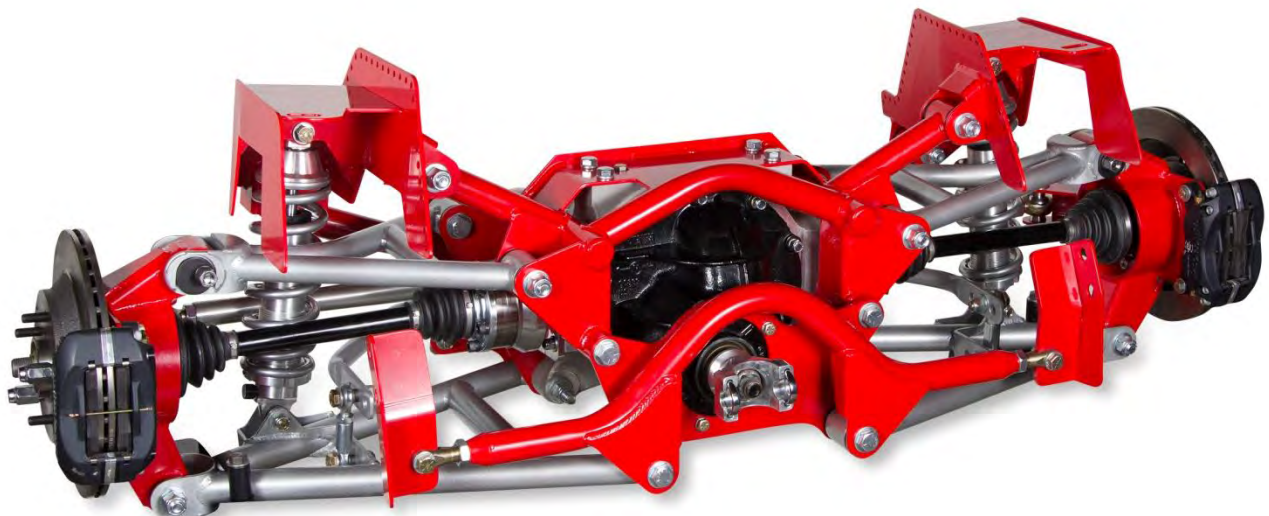

IRC-301 PRO-G IRS, 82-92 CAMARO INSTALLATION INSTRUCTIONS



Please read these instructions completely before starting your installation.

Remember the basic rule for a successful installation:

****** Measure Twice, Drill Once. ******

******Do Not Paint or Powder Coat any suspension components before trial fitting all items ******

For questions on installations please call 800-841-8188 In Illinois (847) 487-0150



Hardware Kit**Main Cradle Assembly**

5/8"-11 x 4" Hex Bolt	(4)
5/8" Washer	(8)
5/8"-11 Nylock Nut	(4)
1.38 Inch OD Bushings	(8)
1/2"-13 x 1.5" Hex Bolt	(2)
1/2" Washer	(4)
1/2"-13 Nylock Nut	(2)

Front Pinion Support Tube

5/8"-11 x 2.5" Hex Bolt	(2)
5/8" Split Washer	(2)
3/4"-16 Clevis End, RH	(2)
3/4"-16 Jam Nut, RH	(2)

Front Pinion Support Brackets

M10-1.5x35mm Flange Bolt	(4)
1/2"-20x1.25" Hex Bolt	(2)
1/2"-20 Nylock Nut	(2)

Upper & Lower Control Arm Hardware

5/8"-11 x 4" Hex Bolt	(6)
5/8"-11 x 6" Hex Bolt	(2)
5/8"-11 Nylock Nut	(8)
5/8" Washers	(16)
5/16"-24 x 1" Hex Bolt	(4)
5/16" AN Washers	(4)

Steering Arm Hardware

5/8"-11x4" Hex Bolt	(2)
5/8"-11x3.25" Hex Bolt	(2)
5/8" Washer	(8)
5/8"x1/2" High Misalignment Rod End Bushings	(8)
5/8"-11 Nylock Nuts	(4)
3/4-16 Jam Nut, RH	(2)
3/4-16 Jam Nut, LH	(2)
Rod End, 3/4" Spherical Bearing 3/4-16 RH Thread	(2)
Rod End, 3/4" Spherical Bearing 3/4-16 LH Thread	(2)

Uprights, Left & Right

1/2" Cam Bolt Adjuster Assembly	(2)
5/8"-11 x 4" Hex Bolt	(2)
5/8" Washers	(2)
5/8"-11 Nylock Nuts	(2)

For questions on installations please call 800-841-8188 In Illinois (847) 487-0150



Hardware Kit (Continued)**Sway Bar, Rear**

1/2"-20 RH Male Rod End W/ Stud	(2)
1/2"-20 LH Female Rod End W/ Stud	(2)
1/2" Jam Nut	(2)
1/2"-20 x 2" Hex Bolt	(2)
1/2"-20 Nylock Nut	(4)
7/8" Diameter Anti-Roll Bar, Rear	(1)
Sway Bar Bushing Bracket & Bushings, Rear	(2)
3/8"-16 x 1.25" Hex Bolt	(4)
3/8" AN Washer	(8)

Brake Bracket Adapter

3/8"-16 x 1.25" Button Head Bolt	(6)
3/8" AN Washers	(12)
3/8"-16 Nylock Nuts	(6)

C-4 Corvette Brake Option #1:

C-4 Brake Caliper w/ integral parking Brake	(2)
C-4 Brake Caliper Bracket	(2)
Brake Bracket Adapter, C-4 Caliper to Upright	(2)

Wilwood Brake Caliper Option #2:

Wilwood Forged Dynalite Brake Kit	(2)
Brake Bracket Adapter, Single Caliper	(2)

Wilwood Brake Caliper and Mechanical Parking Brake Option #3:

Wilwood Forged Dynalite Brake Kit	(2)
MC4 Mechanical Parking Brake Calipers	(2)
Brake Bracket Adapter, Dual Caliper	(2)

Rotor Options:

C-4 Plain Rotors, Steel	(2)
Dimple Drilled & Slotted, Coated, Black	
Wilwood, Plain Rotors	
Wilwood, Drilled & Slotted Rotors	

Low or High HP CV Shafts

Low HP CV-Shafts w/ 27 Spline Hubs	(2)
High HP CV-Shafts w/ 22 Spline Hubs	

Coil Over Shocks

Single Adjustable Billet Coil-Over Shocks	(2)
Double Adjustable Billet Coil-Over Shocks	

For questions on installations please call 800-841-8188 In Illinois (847) 487-0150



Rear springs, 10 inch (2)

Components

Saddle Support, Left (1)
 Saddle Support, Right (1)
 Main Cradle Assembly (1)
 Front Pinion Support Tube (1)
 Lower Control Arm, Left (1)
 Upper Control Arm, Left (1)
 Upper Control Arm, Right (1)
 Pinion Support Bracket, Left (1)
 Pinion Support Bracket, Right (1)
 Upright, Left (1)
 Upright, Right (1)
 Pinion Support Plate (1)
 Rear Hubs (2)

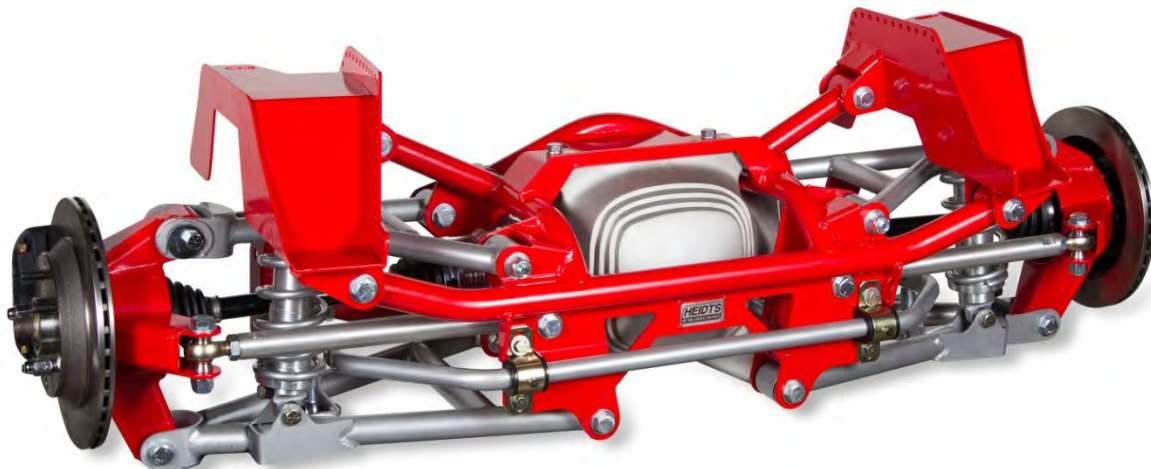

Rear View 3rd Gen IRS

Directions:

Place the vehicle on a 4 or 2 post lift, make sure vehicle weight is on the lift locks. Next remove the stock rear axle, torque arm assembly, lower rear control arms, and drive shaft. The underbody should look like the photo in Figure 1, after everything is removed. Then drain gas from tank, and disconnect and plug all fuel lines. Support the fuel tank and remove the two fuel tank straps. Carefully remove the tank from the car and put in a safe location away from flames, sparks or heat.

For questions on installations please call 800-841-8188 In Illinois (847) 487-0150



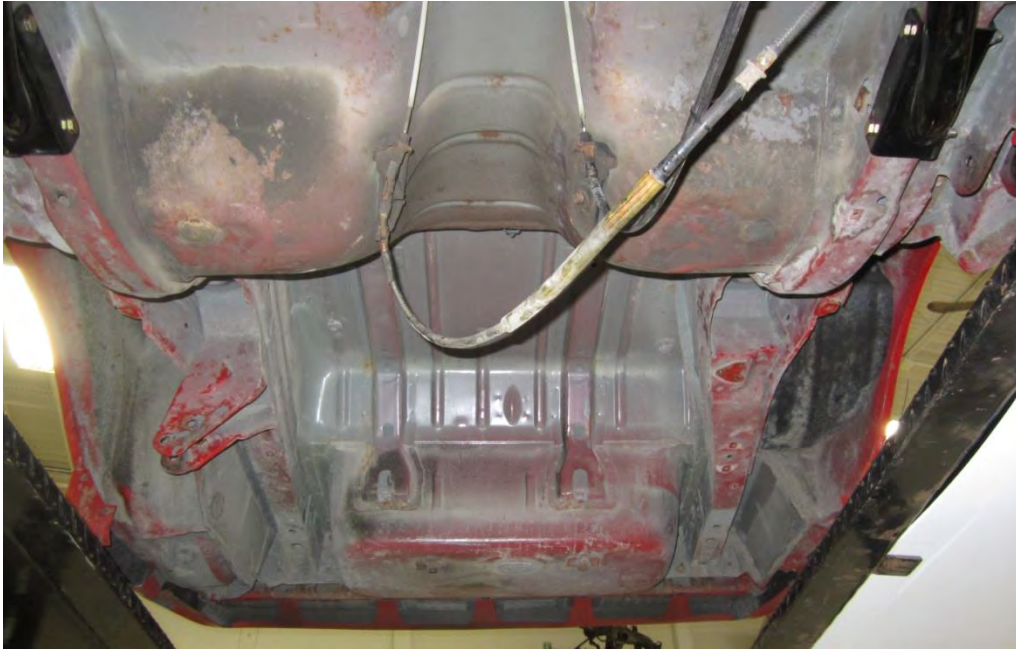

Figure 1

Prep the frame rails by removing the inner sheet metal panels. A “Rotary Spot Weld Cutter” bit will come in handy, you can buy this from “**Drill Master**” p/n **95343**, see **figure 2**.



Figure 2

Mark all the spot welds shown in the photos by circling them with permanent marker on both the drivers and passenger side rear frame rails, as shown in **Figure 3 and 4** below.

For questions on installations please call 800-841-8188 In Illinois (847) 487-0150





Drivers Side Inner Frame Rails, Mark Spot Welds, Figure 3



Passenger Side Inner Frame Rails, Mark Spot Welds, Figure 4

For questions on installations please call 800-841-8188 In Illinois (847) 487-0150





Inner Rail Panel, Removed, Figure 5



Figure 6

Next circle the four spot welds on both sides of the panhard bar mount.

For questions on installations please call 800-841-8188 In Illinois (847) 487-0150





Panhard Bar Mount, Back Side, Figure 7



Panhard Bar Bracket, Front Side, Figure 8

For questions on installations please call 800-841-8188 In Illinois (847) 487-0150



Scribe lines inside Panhard Bar mount to mark cut off locations, **Figure 9**.

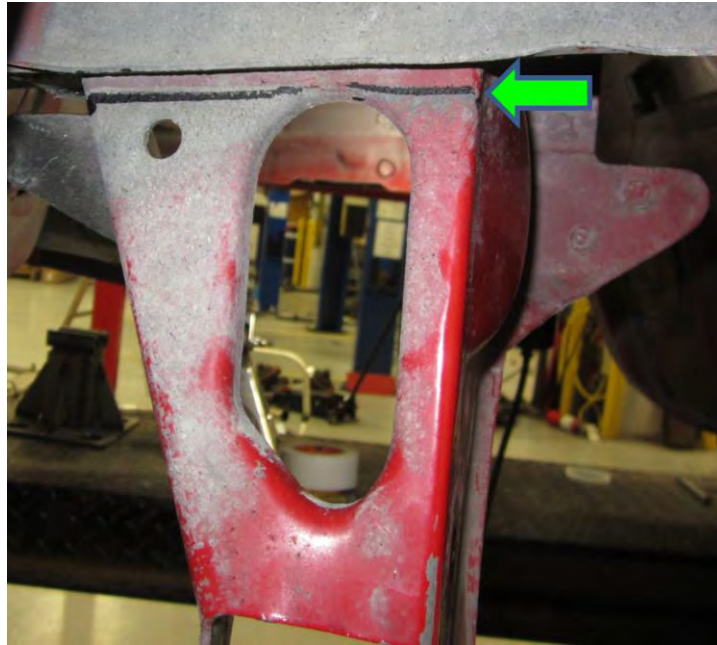

Mark cut off locations, Figure 9

Double check the area to the photos below before you start the trimming process. Then, use a die grinders to cut off and remove the pan hard bar mount, this is no longer needed, Figure 10.

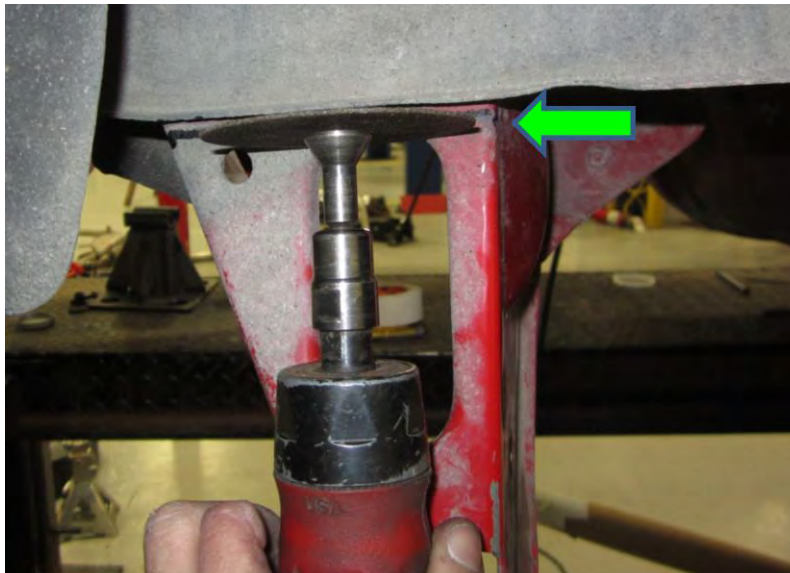

Cut Off Tool, Location, Figure 10

For questions on installations please call 800-841-8188 In Illinois (847) 487-0150



Remove the inner sheet metal support ribbing. When you are finished the drivers side should look like **figure 11** below. Note don't removed the outer frame rail sheet metal ribbing.



Drivers Side, Inner Panel Ribbing Removed, Figure 11

Next weld up all the remaining spot welds, then grind them down flush with the frame rails. Do this for both the drivers and passenger side frame rails. See **figures 12 and 13** below.



Drivers Side Frame Rail, Spot Weld Holes Filled Figure 12

For questions on installations please call 800-841-8188 In Illinois (847) 487-0150





Passenger Side Frame Rail, Spot Hole Welds Filled, Figure 13

Pictured below are the driver and passenger side spring perches, see **figure 14 and 15**.



Passenger Side, Spring Perch Figure 14

For questions on installations please call 800-841-8188 In Illinois (847) 487-0150



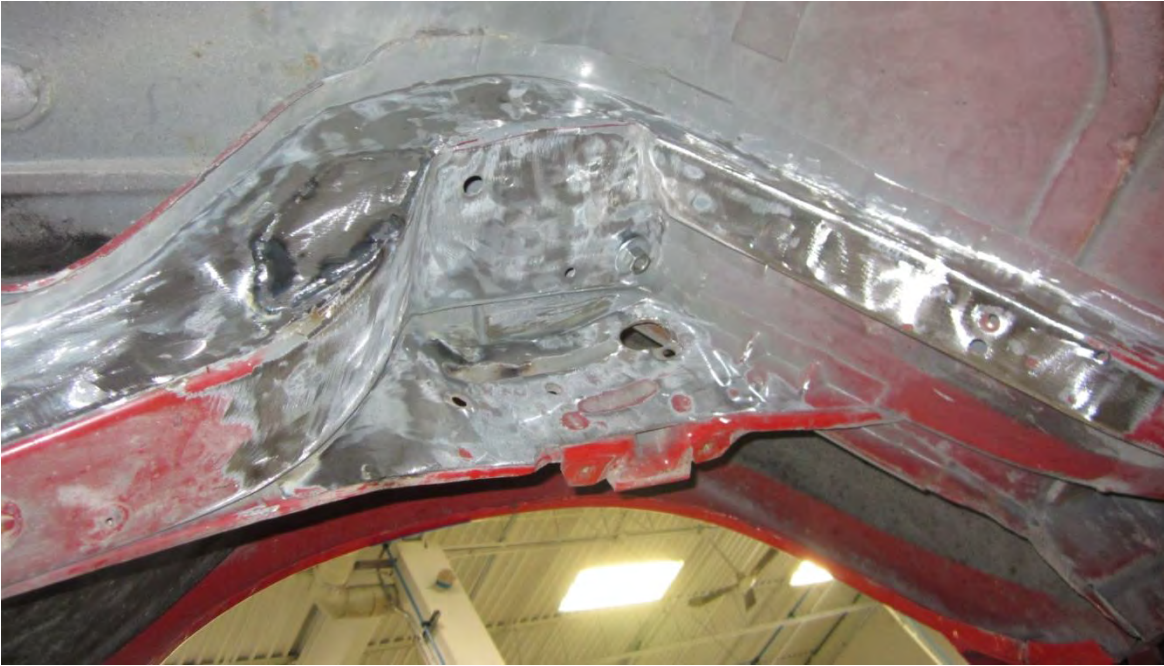

Drivers Side Spring Perch, Figure 15

Neatly trim a 5.25" wide by 3.5" high square cut-out on the outer chassis rail panels, this is needed for clearance for the upper control arms. First find the center of the upper control arm and trim as needed as you run the upper control arm through its travel range. Note other holes located to the left of the square cut out, are not needed. Notice the entire inner sheet metal support ribbing has been removed down to the main frame rail. After you are finished, the left and right frame rails should look like figures 16, 17, 18 and 19.

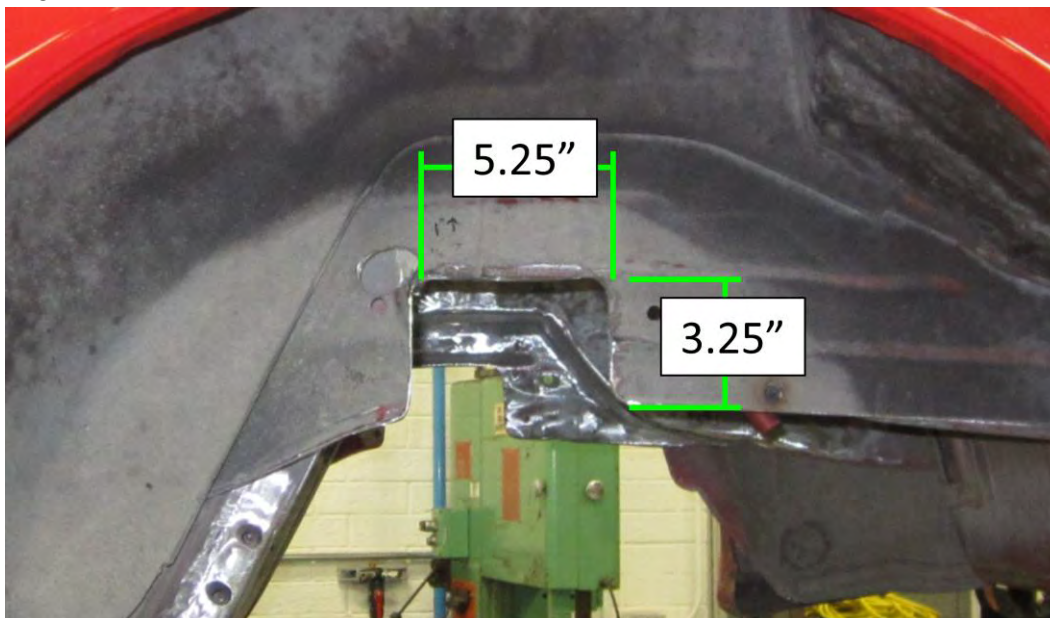

Drivers Side View, Upper Control Arm, Cut-Out, Figure 16

For questions on installations please call 800-841-8188 In Illinois (847) 487-0150



Passenger Side, Upper Control Arm, (5.25' x 3.5') Cut-Out, Figure 17



Inside View, Drivers Side, Upper Control Arm Cut-Out, Figure 18

For questions on installations please call 800-841-8188 In Illinois (847) 487-0150





Inside View, Passenger Side Frame Rail, Figure 18

Remove the rear carpet interior, so you have access to the rear shock tower holes as shown below, **figure 19**. Insert the 1/2"-13 x 1.5" long hex bolts and washers supplied in the kit into each hole.



OEM Rear Shock Mounting Holes, Figure 19

For questions on installations please call 800-841-8188 In Illinois (847) 487-0150



Install the saddles, use the ½"-13 nylock nut, and ½" washers to hold the saddles in place, but don't fully tighten down the bolts yet.

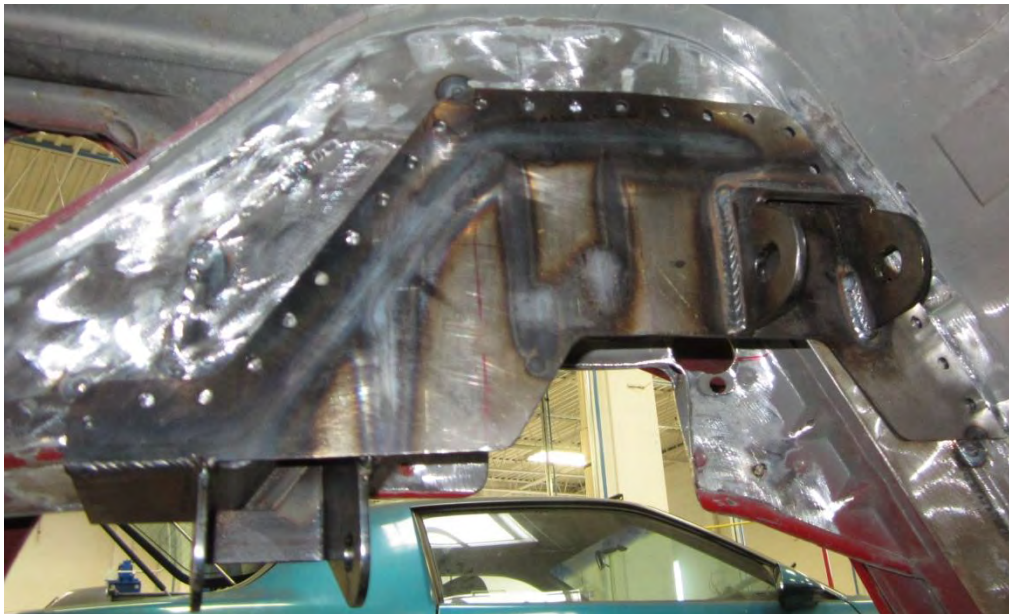

Install Drivers Side Saddle, Figure 20

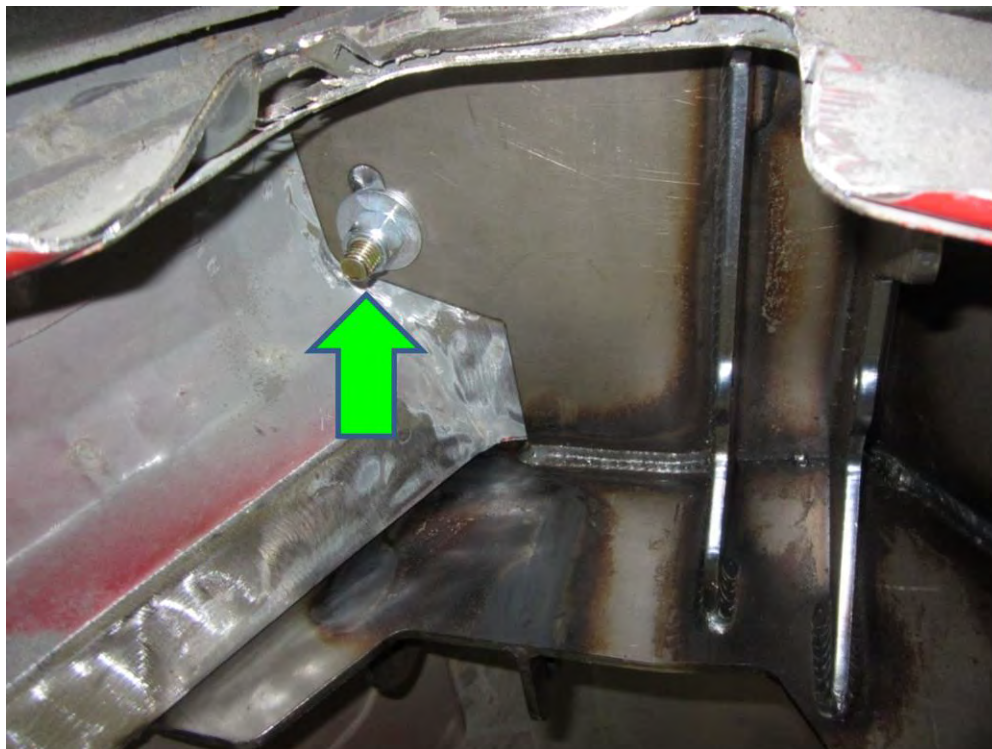

Install ½" bolt and nut to Position Saddle in place, Figure 21

For questions on installations please call 800-841-8188 In Illinois (847) 487-0150





Install Passenger Side Saddle, Figure 22



Install 1/2" Bolt to position Saddle in place, Figure 23

For questions on installations please call 800-841-8188 In Illinois (847) 487-0150



Next find the main cradle assembly, make sure all 8 poly-bushings and 4 steel bushing sleeves have been installed. Use some grease on the out diameter of the bushing to help ease installation. Then raise the main cradle assembly so that it fits into the brackets on saddle supports. Install the 5/8"-11 x 4" long bolts, washers and Nylock nuts from the rear side, as show in the picture below.



Main Cradle Assembly, Front View Figure 24



Main Cradle Assembly, Drivers Side View Figure 24

For questions on installations please call 800-841-8188 In Illinois (847) 487-0150



Main Cradle Assembly, Rear View Figure 25

Go back and tighten the two 1/2"x1.5" bolts that are supporting the left and right saddles. Also tighten the four 5/8" x 4" long bolts that hold the cradle to the left and right saddles.

Now it's time to weld up the saddles to the frame rails. With the main cradle assembly still installed, weld as much of the saddles in place as possible. We recommend starting with the 24 spot weld holes, then weld around the perimeter of the saddles as shown below. Weld the spot welds first let the frame rails cool down then work around the perimeter of each saddle to minimize distortion. Remove the main cradle assembly and finish welding the spots you weren't able to reach with the cradle installed.

For questions on installations please call 800-841-8188 In Illinois (847) 487-0150





Welded Drivers Side Saddle, Figure 26a

Next install the gas tank and the gas tank straps, after the welds have cooled down.



Figure 26b

For questions on installations please call 800-841-8188 In Illinois (847) 487-0150



At this point the rear end housing can be assembled. Install the stub axle seals into the housing ends, one per side. Insert one seal into each side of the housing ends, with lips of the seal pointing inward, use a mallet to slowly tap the seals in until they bottom out on the shoulder of the bore. A seal installation tool will ensure that the seals are installed square. Do not tap on the seal directly, as the mallet could deform the seal, and cause an axle leak **See Figures 27-29.**



Center Section, Figure 27



Axle Seal Installed, Figure 28

For questions on installations please call 800-841-8188 In Illinois (847) 487-0150



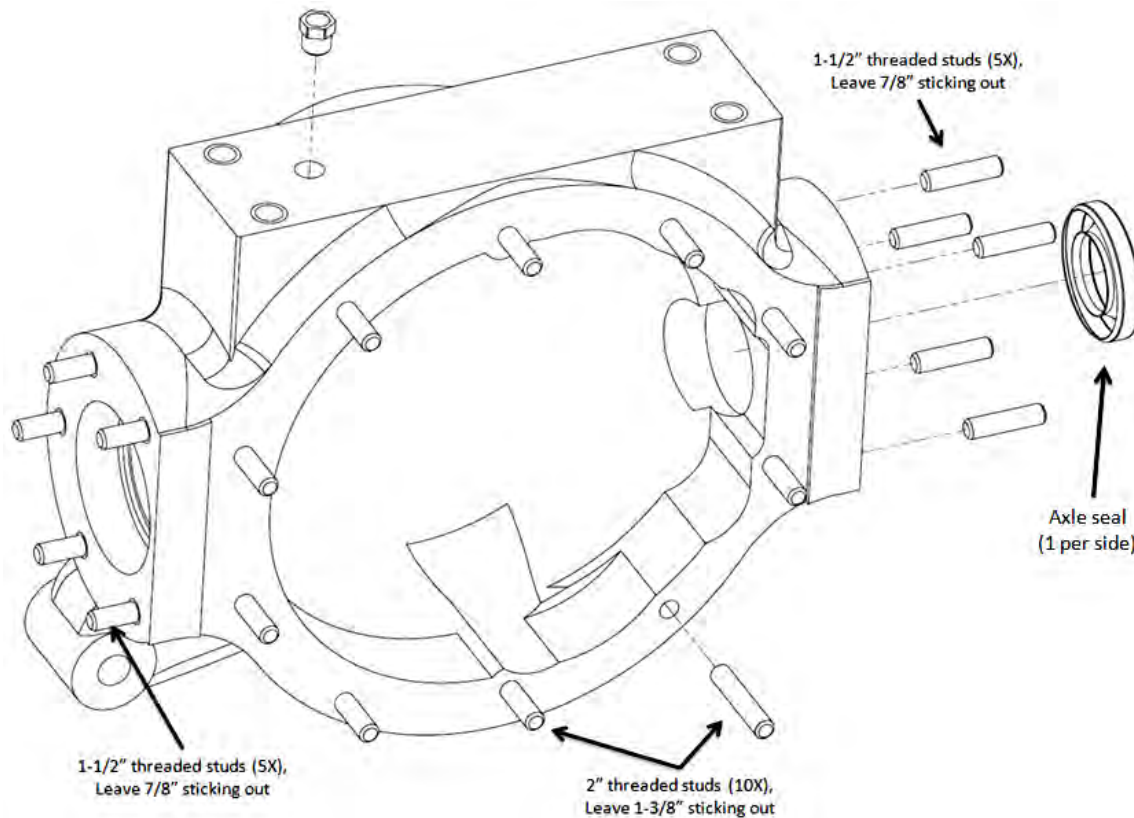

Center Section Diagram, Figure 29

The studs can be installed next. The 1 ½" double threaded studs will be installed in the axle flanges and the 2" studs will be used for the 3rd member. Place the studs in a vice with a pair of soft jaws, to prevent damage to the threads when clamping. Using a wrench, thread on the 3/8" nylock nut until the nylock ring breaks past the threads. For the 2" studs the nylock nut is installed on the shorter threaded end of the stud. **See Figures 29, 30 and 31.**

For questions on installations please call 800-841-8188 In Illinois (847) 487-0150





Figure 30



Figure 31

Install the 3RD member using the 3/8 x 2" long double threaded studs, nylock nuts and AN washers. Install using the Ford 9" third member gasket and or gasket sealer. If installing your own 3rd member you will need a 31 or 33 spline axle shafts. Use thread locker on the studs. **Torque studs to 40 ft-lbs.**

The front pinion plate can be installed after the 3rd member is installed. Uninstall the five front bolts from the pinion retainer cover. Install the pinion mounting plate on the pinion carrier as shown in **Figure 33**. Use the 3/8-16 x 1 1/4" grade 8 bolts and washers that were just removed. Use thread locker on the bolts. **Torque the 3/8 bolts 35-40 ft-lbs.** See **Figures 32 and 33.**



Figure 32

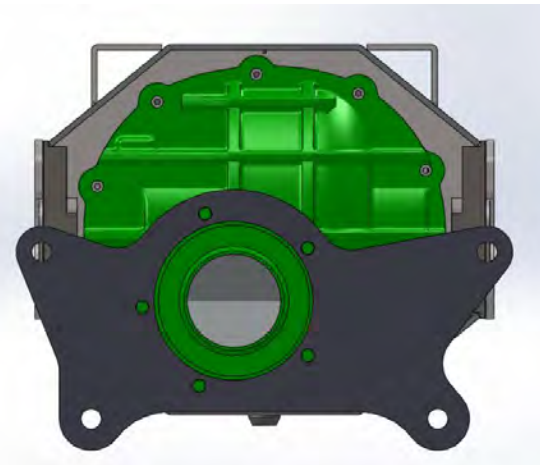

Figure 33

For questions on installations please call 800-841-8188 In Illinois (847) 487-0150



Install the stub axle into the housing using white grease on the splines for ease of installation. The longer stub axle goes into the passenger side. Slide the stub axle into the housing until the bearing bottoms out in the housing bore. Install the bearing retainer plates using the 1 3/4" double threaded studs with the previously installed nylock nuts and washers. The machined sides of the bearing retainer plates face the center housing. **Torque the 3/8" studs to 50 ft-lbs. See Figures 34, 35a and 35b.**



Figure 34

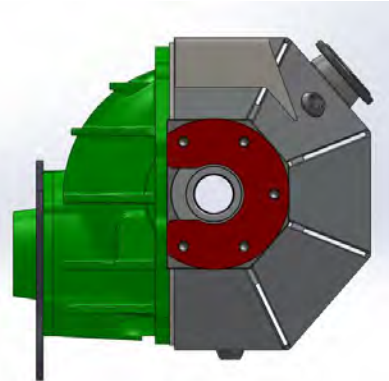

Bearing Retainer Plate, Figure 35a

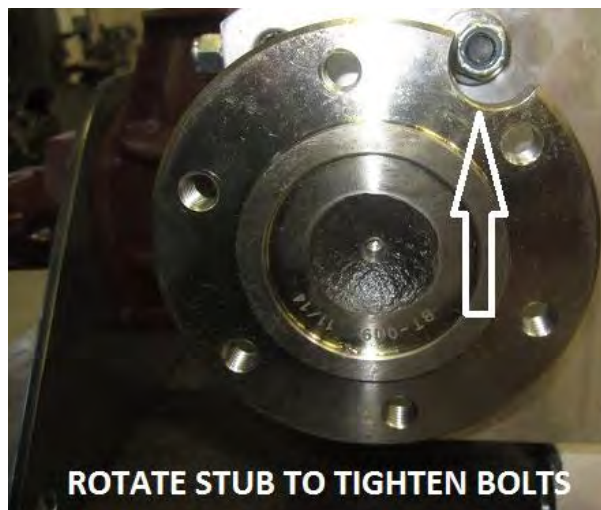

Figure 35b

For questions on installations please call 800-841-8188 In Illinois (847) 487-0150



Install the drain plug on the bottom of the housing and the breather vent into the top. Use anti seize on the plug and vent. **See Figures 36-39.**



Figures 36-39

Install the cradle assembly onto the rear end housing using four ½-13 x 1" hex bolts and 1/2" washers. **Torque bolts to 70 ft-lbs, See Figure 40.**

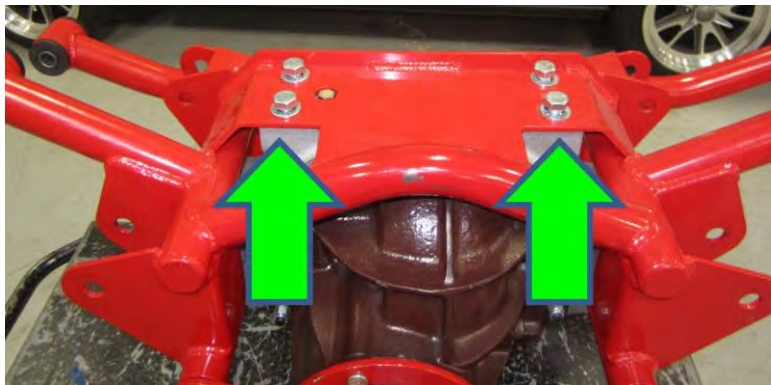

Main Cradle Bolted to Rear End Housing, Figure 40

For questions on installations please call 800-841-8188 In Illinois (847) 487-0150



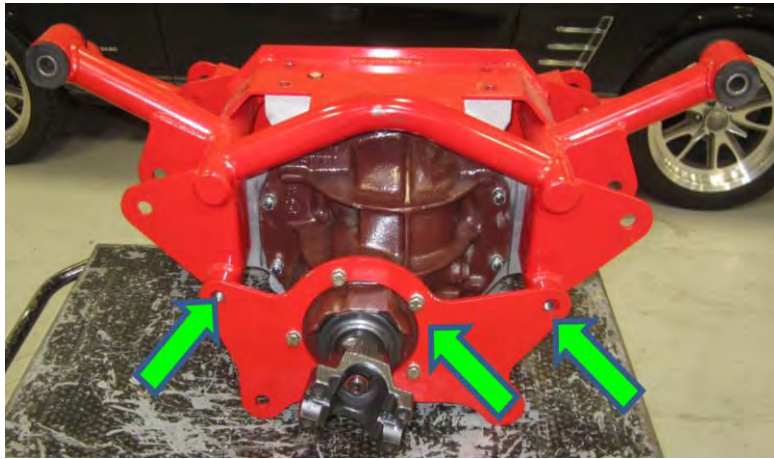

Front View, Figure 41



Rear View, Figure 42

Attach the front pinion mounting plate to the cradle assembly with the two 5/8"-16 x 2.5" bolts and 5/8" washers. **Torque bolts to 75 ft-lbs, see Figure 41, 43, 44.**



Figure 43



Figure 44

For questions on installations please call 800-841-8188 In Illinois (847) 487-0150



Reinstall the main cradle assembly back into the saddle supports using the four 5/8-11x4" hex bolts, washers and Nylock nuts. **Torque bolts to 75 ft-lbs as shown in figure 45, 46.**



Front Pinion Plate, Figure 45

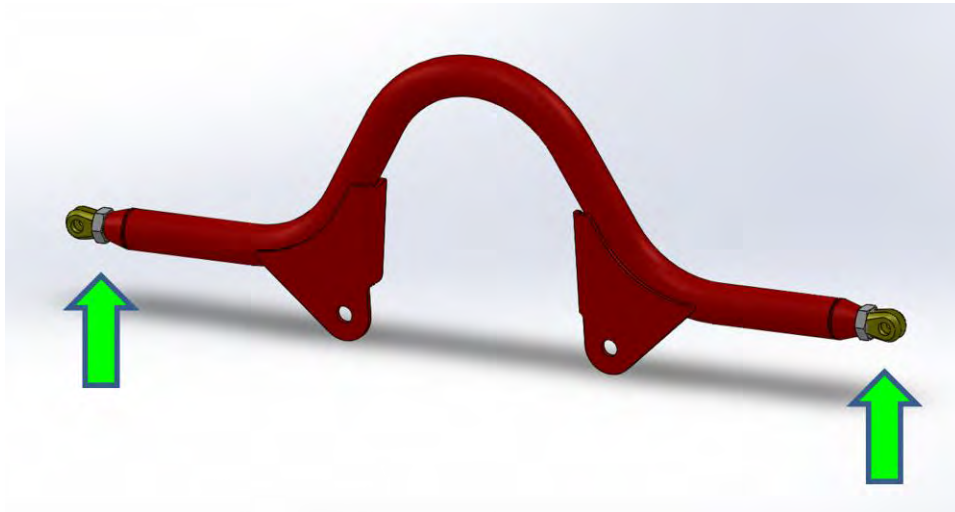

Figure 46

Now it's time to install the front pinion support tube. Assemble the two 3/4"-16 RH clevis ends and 3/4-16 jam nuts in to the ends of the front pinion support tube as shown in **figure 47a**. You can leave the clevis ends loose for now, they will need to be adjusted later. Position the front pinion support assembly on the front side of the cradle and insert two 5/8"x 4" bolts through each of the 5/8" holes to hold up the pinion support tube. Next install the left and right lower control arms by remove one of the 5/8"x 4" bolts you just installed. Install the lower control arm, then reinsert the 5/8"x 4 bolt though the front control arm bushing. Use the the two 5/8"x 6" bolts, washers and nylock nuts to mount the rear control arm, refer to **Fig 47c cross section view** for the hardware assembly. Make sure the lower control arms are mounted correctly, note the shock brackets will face upwards and also be located toward the rear, see **Figures 47b, 47c, 48**.

For questions on installations please call 800-841-8188 In Illinois (847) 487-0150





Front Pinion Support Tube w/ Clevis Ends, Figure 47a

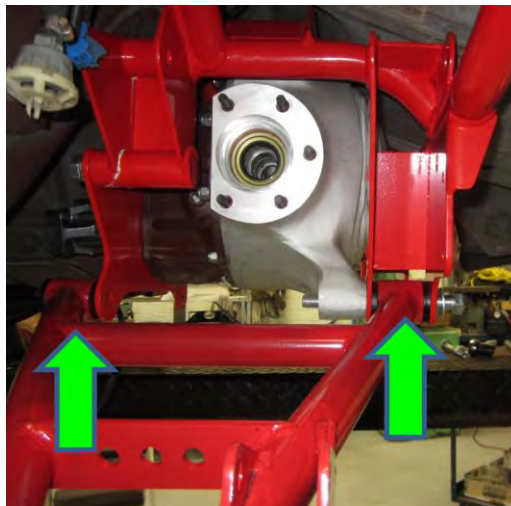

Lower Control Arm, Drivers Side, Figure 47b

For questions on installations please call 800-841-8188 In Illinois (847) 487-0150



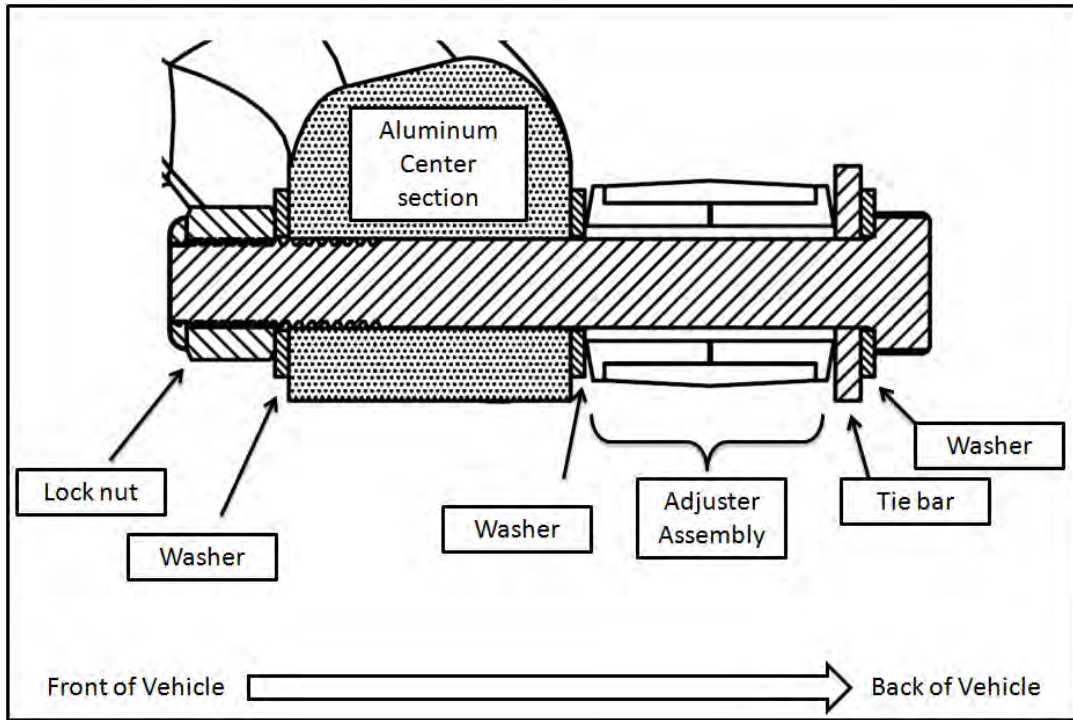

Rear Lower Control Arm Assembly, Cross Section View, Figure 47c

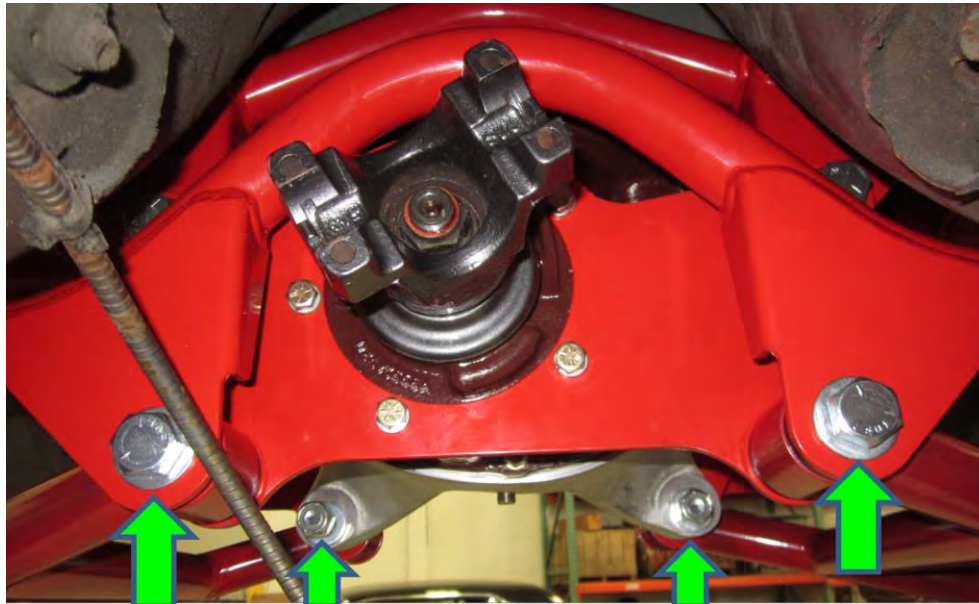

Front Pinion Support w/ Lower Control Arms, Figure 48

For questions on installations please call 800-841-8188 In Illinois (847) 487-0150



Install the upper control arms using the four 5/8" x 4" long bolts, washers and Nylock nuts, see **figure 49a, 50c**. The bowed sides of the upper control arms should face the rear of the car. **Torque to the 5/8" bolts to 75 ft-lbs.**

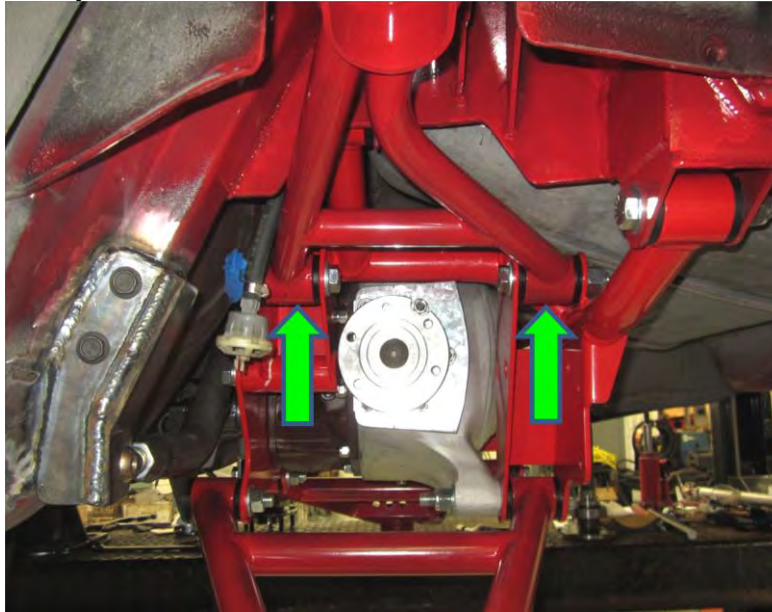

Upper Control Arms, Drivers Side Figure 49a



Left Pinion Support Bracket, Figure 50a

Next mount the left and right pinion support brackets **figures 50a, 50b, 50c**. Use the four M10-35mm long flange bolts to mount the brackets to the chassis. Use the two 1/2 x 1.25" long bolts and nuts, to attach the clevis, you will need to adjust the clevis 1/2 turn at a time so that the 1/2 bolt sides through the bracket hole.

For questions on installations please call 800-841-8188 In Illinois (847) 487-0150



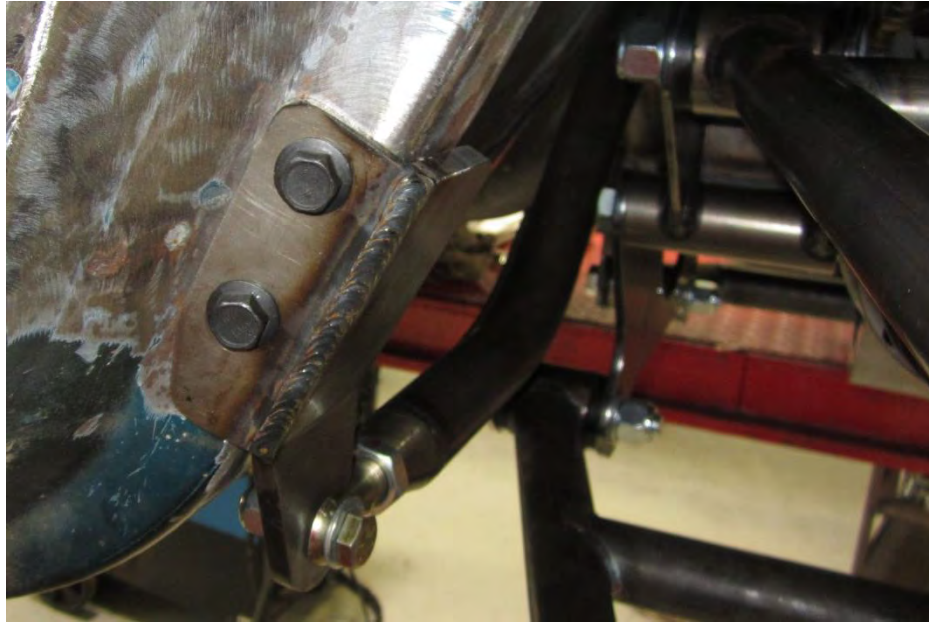

Left Pinion Support Bracket, Figure 50b

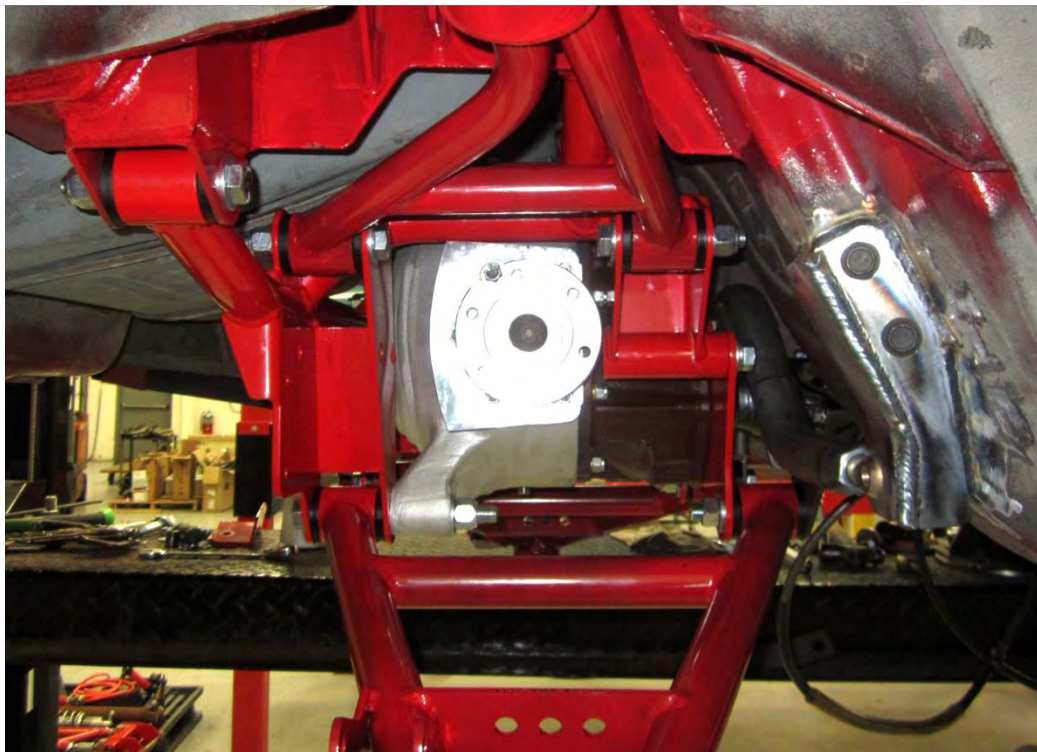

Right Pinion Support Bracket, Figure 50c

For questions on installations please call 800-841-8188 In Illinois (847) 487-0150



Next install the aluminum CV adapter spacer, to the end of the half shafts and use the twelve M10 x 80mm long bolts and split lock washer to fully install the CV joint axles to the axle stubs. Use thread locker on the bolt and **Torque to 51-57 ft-lbs. See Figures 51-54.**



Apply Thread Locker, Figure 51



CV Adapter Flange, Figure 52

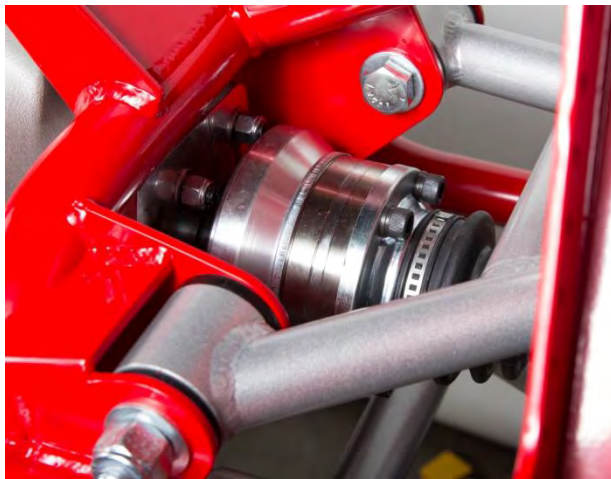

Figure 53



Figure 54

Install the outer bearing assemblies using the six M12 x 60mm long bolts and washers. If bearing assembly does not seat without applying pressure, carefully open the hole using a barrel sander. Use thread locker on the M12 bolts. Insert the eight polyurethane bushings in to the left and right uprights. Then insert the four bushing sleeves. **Torque bolts to 65 ft-lbs. See Figures 52-55.**

For questions on installations please call 800-841-8188 In Illinois (847) 487-0150





Figure 52



Figure 53



Figure 54



Figure 55

Apply grease to the splines of the CV joint axles. Install the stub axles into the bearing assemblies until the CV joint axle bottoms out against the hubs. Place the nut back onto the threads and **DO NOT** tighten. Raise the lower control arm and outer upright until the CV joint axle holes align with the holes of the brake rotor and the stub axles. Use the twelve M10 x 80mm long bolts and split lock washers to fully install the CV joint axle and rear brake rotor to the axle stub. Use thread locker on the M12 bolts. **Torque M12 bolts to 70 ft-lbs. See Figures 56-61.**

For questions on installations please call 800-841-8188 In Illinois (847) 487-0150





Figure 56



Figure 57

Next use the Cam bolts to attach the upper control arms to the uprights. Make sure the Cam bolt washers fit into the “C” shaped grooves welded on each side of the uprights.



Cam Bolts, Figure 58



Cam Bolt installed, Figure 59

Then install the steering arms, use the spacer, and the two misalignment spacers or the poly bushings on each end of the rod ends. Attach the steering arms to the main cradle and the up rights. **See figures 60, 61, 62.**

For questions on installations please call 800-841-8188 In Illinois (847) 487-0150





Figure 60

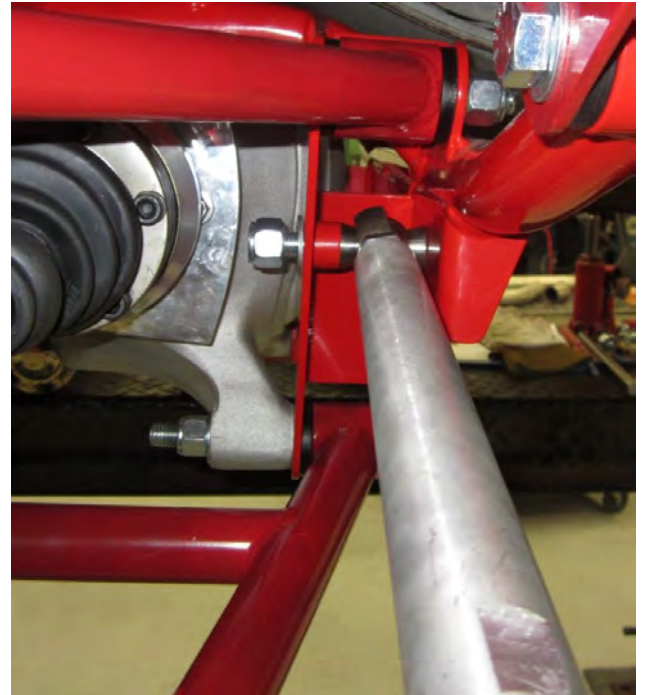

Figure 61



Figure 62

Next assemble the rear coil over shocks. The assembled shock spacers should look like **Fig 63a, 63b**. Install the rear shocks using the $\frac{1}{2}$ " x 2.75" long bolts, washers and nuts.

For questions on installations please call 800-841-8188 In Illinois (847) 487-0150



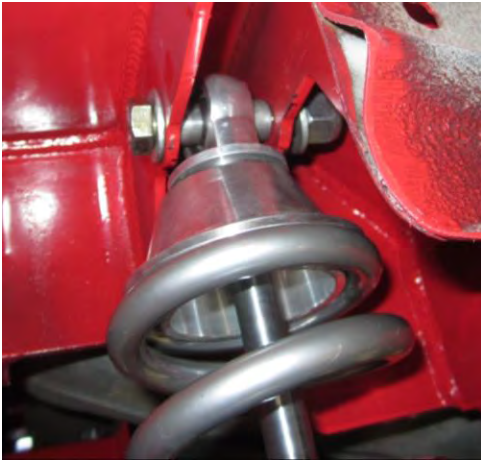

Figure 63a

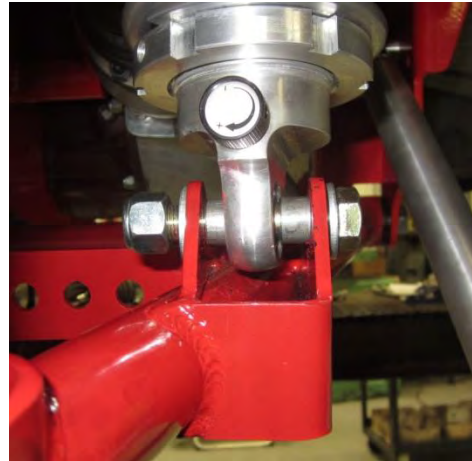
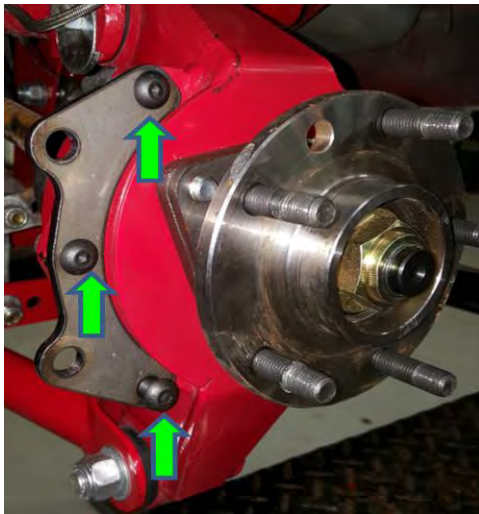

Figure 63b

There are three different brake options that are available for the IRS. The first option includes: the C-4 Corvette calipers with integrated parking brake. The second option includes the Wilwood calipers, no parking brake. The third is option is the Wilwood brake calipers with mechanical parking brake caliper. Each option has its own brake caliper mount, make sure your kit has the correct mount.

Brake Option 1: The following are instructions to install the C-4 calipers. Use the six 3/8"-16 x 1.25" button head screws, washers and nylock nuts. Fasten the brake caliper adapter to the outside side mount located on the front side of the uprights. **Torque the 3/8" bolts to 20 ft-lbs, see figure 64a.** Next slide the rear rotors on over the wheel studs, then install the C-4 brake caliper brackets. Note the rear rotor are fastened through the clamping force of the lug nuts after you install the rear wheels. Use the four supplied M12x20mm Flange bolts to fasten the C-4 Caliper mount brackets to the adapter. **Torque bolts to 131 ft-lbs see figure 64b.**



Brake Caliper Adapter, Fig. 64a

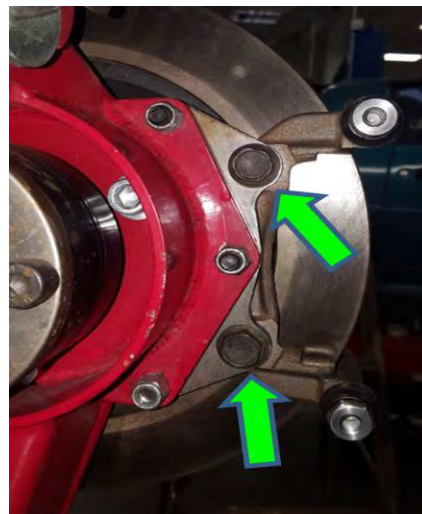

C-4 Brake Caliper Mount, Fig. 64b

For questions on installations please call 800-841-8188 In Illinois (847) 487-0150



Install the brake pads as shown in **figure 64c**, note the pad with the anti-rattle clip goes on the inside of the rotor. Next install the brake caliper, make sure that the two torsional springs on the pads are preloaded evenly against the underside of the brake caliper. Note the torsional springs hold the pads down into the caliper bracket and are necessary so the pads don't get knocked out of place and wear unevenly. Use the two M8x20mm long bolts to attach the brake caliper to the caliper pin sliders. We recommend you use thread locker on these bolts or safety wire the bolts so they don't come loose. **See figure 64d.**



Figure 64c



Figure 64d

Brake Option 2

The following instructions are for mounting Wilwood brake calipers. We recommend reading through the instructions that come with the Wilwood brake kit. First use the six supplied 3/8"-16 x 1.25" long button head screws, washers and nylock nuts to mount the caliper adapter to the outside side mount located on the uprights. **Torque these 3/8" bolts to 20 ft-lbs, see figure 64a, pictured above.**

Then slide the rear rotors on over the wheel studs. Next install the brake calipers, use the four 3/8"-24 x 1.25" long hex bolts, .063" thick washers and .032" shim washers to mount the calipers, to the caliper adapter bracket. Use the .032" shim washers to space the caliper it is positioned on center with the brake rotor. Use thread locker on the caliper bolts. Thread the bolts into the caliper brackets. Spread the end of the cotter pin in. **Torque bolts to 20 ft-lbs. See Figures 65a, 65b, 66, 67.**

For questions on installations please call 800-841-8188 In Illinois (847) 487-0150



Reference the Wilwood instructions for correct caliper spacing diagram and verify the alignment is correct. Note each caliper adapter bracket should have two clinch nuts that are pressed into it. Make sure the clinch nuts are facing away from the center of the car. See the Wilwood instruction diagrams for more details. These instructions can also be found online if they are missing from your kit. Don't forget to slide in the brake pads and cotter pin and spread the cotter pin ends.



Figure 65a



Figure 65b



Figure 66

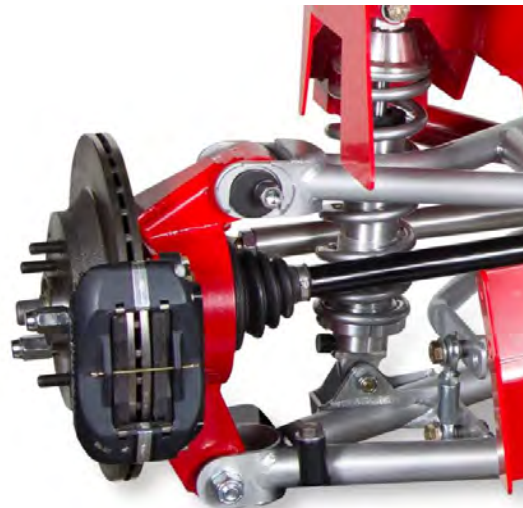

Figure 67

For questions on installations please call 800-841-8188 In Illinois (847) 487-0150



Option 3:

The third option uses both the Wilwood brake caliper and MC4 Mechanical parking brake. Both calipers mount on the same adapter bracket. Follow the instructions listed above in Option 2 for mounting the brake calipers. Then refer to the Wilwood instructions for mounting MC4 parking brake calipers, see **figure 64d**, pictures below.



MC4 Mechanical Parking Brake, Figure 64d

2nd Brake Rotor Options

If you have the dimple drilled and slotted rotors, pay close attention to the arrow on the rotors. See **figure 64e** below. The wide aperture slots on these brakes are designed to draw cool air under the brake pad and rotor interface and help cool the temperature of the brake pad during heavy braking.



Dimple Drilled & Slotted Rotor, Fig. 64e

For questions on installations please call 800-841-8188 In Illinois (847) 487-0150



If you have the Spec 37 Rotors look for the small directional arrow located on the inside of the rotor and mount accordingly, **see figure 64f**. When attaching the C-4 brake hat to the rotor use removable thread locker on the 5/16-18 button head Torx head screws. Follow the recommended break in procedure provided in Wilwood instructions.

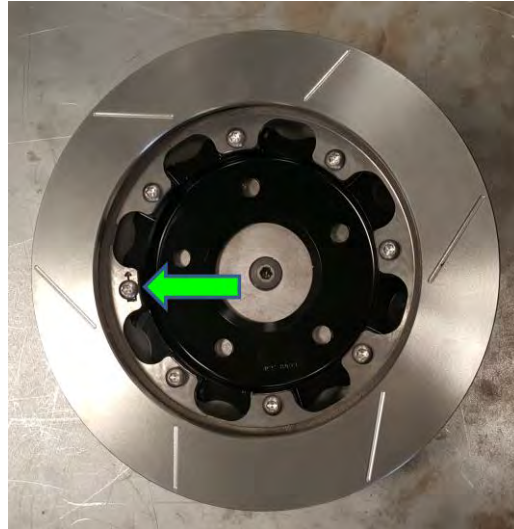

Wilwood GT 36 Curved Vane Spec-37 Rotors, Figure 64f

Warning

Note if your `82-`92 Camaro is outfitted with drum brakes on the rear axle, you will need to purchase a combination valve. If you intend on using the stock master cylinder, you will need the combo-valve to reduce the rear line pressure on the calipers so the rear brake pads don't drag, and wear out prematurely. The "combination valve" acts like a proportioning valve and allows you to reduce the rear pressure coming from the OEM master cylinder. Please note some of the `91 Camaro GTA 4-disk brakes, actually came with drums in the rear because of supply shortages. Please double check which master cylinder your car is equipped with so this isn't a problem on your car.

Another option instead of adding combination valve it the replace the OEM master cylinder with Wilwood 4-disk brake version, p/n XXX.XXX. This master cylinder has the correct line pressures for to run 4-disk brakes.

Now on to the rear sway bar, mount the sway bar bushing and brackets on the sway. Use the two rectangular sway bar spacers in between the cradle and the sway bar mounts. Use the four 3/8"-16 x 1.25" long hex bolts, 3/8" AN washers and 3/8" Nylock nuts to attach the sway bar mounts to the rear of the main cradle. **Torque the four 3/8" bolts to 20 ft-lbs. See figure 70.**

For questions on installations please call 800-841-8188 In Illinois (847) 487-0150





Rear Sway Bar, Figure 70

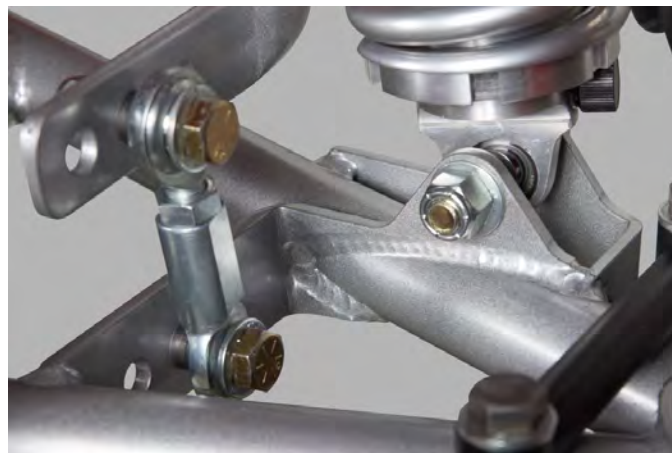

Sway Bar, Spherical Bearing Rod End links, Figure 71

Assemble the spherical bearing rod end links as shown in **figure 71**. There are three pairs of holes that can be used to change the rear sway bar rate. Move the link toward the front of the car softens the sway bar rate. Moving the rod end rearward stiffens the sway bar rate. Note you can vary the left and right side to get in between rates for a total of six different bar rates, one being the disconnected, i.e. no rate.

Next install rear drive shaft. We suggest at this point you snug down any bolts or nuts that may have been left loose in the prior steps.

You are coming into the final home stretch. Next you want to route the brake lines, install the combo valve and bleed the brakes with a high quality brake fluid. Then install the parking brake cable to the mechanical parking brakes. Verify the brake lines and

For questions on installations please call 800-841-8188 In Illinois (847) 487-0150



cables are secured down and away from any heat sources, rub/ wear points or pinch points in the suspension.

Finally, you are ready to set the alignment of your vehicle. Be sure to do so with the arms and shocks set at ride height (the lower control arms should be 1 to 2 degree going downhill towards the wheels). You may want to take you car to an alignment shop for an alignment. If you have a digital angle finder and toe plate and want to align it yourself it's pretty easy. Start by loosen the cam bolt adjuster nut located in the top upright adjuster to set camber. The cam bolts are on eccentric cams, so when the bolts are rotated about the center, the cams will tilt the upright and very your camber. When you achieve your desired camber setting; tighten the cam nut assembly down to lock the setting in place. Just be sure that both sides have equal camber settings, or the car will tend to pull to one side and have uneven tire wear.

To set the vehicle toe, loosen up the jam nut on each side of the steering arm, then turn the steering arm to set the toe to the specification below. Use the machined flats on steering arms to lengthen or shorten the link. When you achieve your desired Toe setting, lock both jam nuts down while holding the steering arm across the machined flats.

Here are the recommended alignment specifications:

Alignment Specifications:

Camber: 0° - .5° Negative

Toe: 0 - 1/16 Toe-In

Since you are now to the point where you have a finished, running car (we hope!) it is time to test drive it. After a few hundred miles, double check the ride height and the alignment. The springs may have settled, which would change the ride height and the camber setting. Readjust the ride height before changing the alignment. After this initial setting period, the springs and bushings should have pretty much taken their final set, so you should be on your way to many miles of cruising in style.

For questions on installations please call 800-841-8188 In Illinois (847) 487-0150

