

HEIDTS

SUPERIDE II

INSTALLATION INSTRUCTIONS 1941-1948 FORD INDEPENDENT FRONT SUSPENSION

Please read these instructions *completely*
before starting your installation.
Remember the basic rule for a successful installation:
Measure Twice, Weld Once.



You are about to install your *HEIDTS* suspension system. You are probably wondering how complicated installing a complete I.F.S. system really is, with all those pieces, all the angles, anti-dive, geometry...Don't worry. The *HEIDTS* I.F.S. kits are designed so all that is taken care of for you. Just follow the instructions step by step, reading each step completely, and in a very short time your car will be sitting on the nicest riding I.F.S. kit available.

Your car may be using stock frame rails or you may be using new reproduction boxed rails. If you are using new boxed rails, you may skip to Step 4. If you are using stock rails start at Step 1.

1. First, remove all stock components. Any suspension brackets, steering or shock brackets that are welded to the frame should be taken off and ground smooth.
2. The stock crossmember will need to be removed next. To hold the rails in place, a temporary brace can be clamped or tack welded across the rails. Drill out the rivets and remove the crossmember. The rivet holes can then be welded up and ground smooth.
3. Prepare the frame for installation. Trim the lower flange off the frame section to the 1-1/2" dimension shown. The large hole in the stock boxing plate just behind the axle C/L should be plugged and welded to provide weld surface for the new crossmember.
4. Note that on the underside of the frame rails are the rubber axle snubbers (or the holes for them) above the axle. Using the center of those holes, scribe a line around the rails. See Figure 1. This will be the axle center line. The wheelbase should be 114". As a final check, just to be safe, you could temporarily place a fender on the frame and stand a wheel in place in the opening, centering the wheel in the fender opening. Slide a bar or broom handle through the wheel center hole. It should fall on your correct axle centerline. If the crossmember is installed in the wrong place now, it can not be compensated for later. REMEMBER THE BASIC RULE-MEASURE TWICE, WELD ONCE.
5. Trial fit the new crossmember onto the rails. It should be located with its centerline on the marked axle centerline. See Figure 2. The frame is approximately 31-1/4" wide at the axle centerline. Pull the rails in to fit the crossmember. There may be a gap between the crossmember uprights and the frame rails at the 31-1/4" dimension. Reproduction frame rails are sometimes thinner than stock. If this is the case, a spacer of filler may be required. If the crossmember is too wide, grind it to fit snug. It should be seated flat against the bottom of the frame rails. Clamp in place, double check your measurements, making sure crossmember is squared on the frame, then weld in place. Weld all around, top, sides and bottom. This crossmember keeps the front frame rails from twisting and flexing, so good strong welds are required.
6. The upper control arm mounts are next. See Figure 3. They are positioned with the anti-dive angle of the upper arms higher in front, as shown. The upper mount should line up with the main crossmember and should contact the entire top ends of the crossmember. If the upper mounts do not fit up to the crossmember, grind the edges of the upper mounts where they sit on the frame. If there is a gap between the frame and the upper mounts, grind the edge where the upper mounts contact the crossmember. Care must be taken, however, to grind an equal amount off the entire edge so the angle of the upper mounts is not changed. Now check the dimension across the upper arm cross tubes. That dimension should be 28-1/8" \pm 1/8". It is more important that the tubes are parallel and square as viewed from the top than exactly that dimension. See Figure 4. Again, cross measuring, squareness and accuracy cannot be overstressed at this stage, as the closer the installation is at this point, the easier your final wheel alignment will be. Good, strong welds are also required here, as the weight of the car hangs on the upper coil-over mounts.
7. Now assemble all the suspension components. Note: the shim washers supplied may be needed to center the calipers on the rotors. Do not install the coil-over assemblies just yet. Position the car at approximately the ride angle or rake that the car will sit at when finished. Prop up the lower control arms so they are level. This is the designed midpoint of the suspension system. Now set the caster, camber and toe in. The settings are as follows:
 - CASTER 1° positive
 - CAMBER 1/4° positive
 - TOE-IN 1/8" + 1/8"
8. The caster and camber settings are done with the adjusters in the upper control arms. Both adjusters are screwed in or out an equal amount to change the camber, and they are adjusted opposite each other to change caster. Approximately 1° of caster is built into the crossmember already, so not much change is required there. The interesting thing about the caster setting is that you can experiment with different settings and actually "tune" the characteristics of the handling of your car to your driving style. 1° of caster will give a nice road feel and good low speed drivability. 2° or 3° will yield better high speed stability and tracking, putting a better self-centering characteristic in the steering wheel, but will tend to start to make parking slightly more difficult. Have fun with this one, as it truly makes your car your own car. Just be sure that both sides have equal caster settings, or the car will tend to pull to one side.
9. Next relax the suspension and install the coil-overs. The spring seat rings should be at the bottom position, providing the least amount of preload. The car should now be placed on the ground. The spring seat rings should be adjusted to position the ride height of the suspension so the lower control arms are level. Make sure that at this point you are working with a finished, fully weighted car, not just a frame, or a frame and body. At this point do a quick double check of your alignment.
10. Since you are now to the point where you have a finished, running car (we hope!) it is finally time to test drive it. After a few hundred miles, double check the ride height and alignment. The springs may have settled, which would change the camber setting. Re-adjust the ride height before changing the alignment. After this initial settling period, the springs and bushings should have pretty much taken their final set, so you should be on your way to many miles of cruising in style, independently.

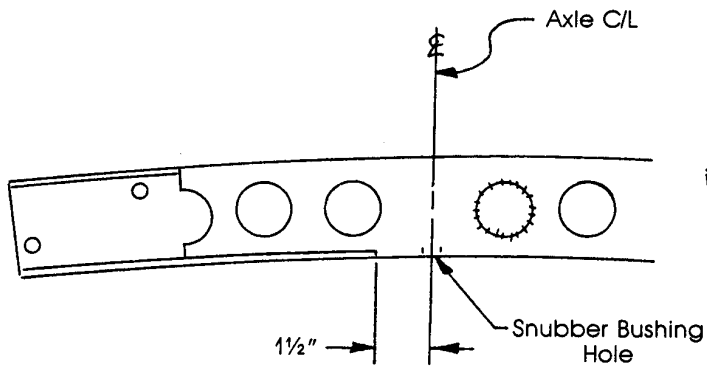

Figure 1

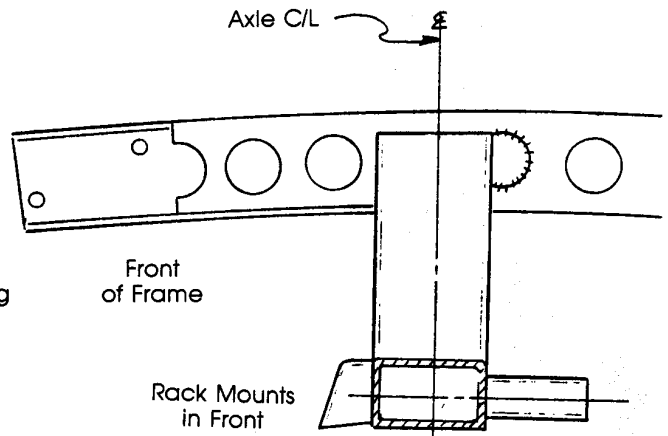

Figure 2

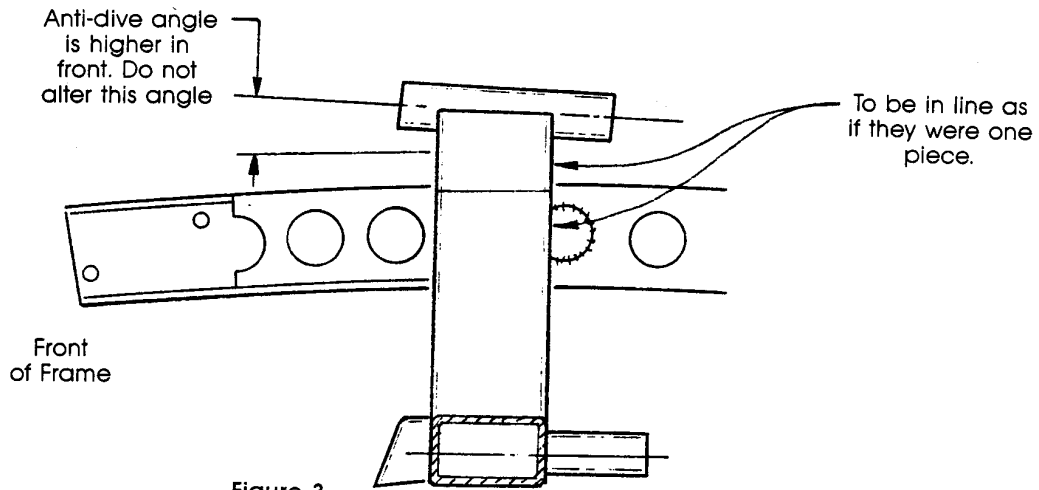

Figure 3

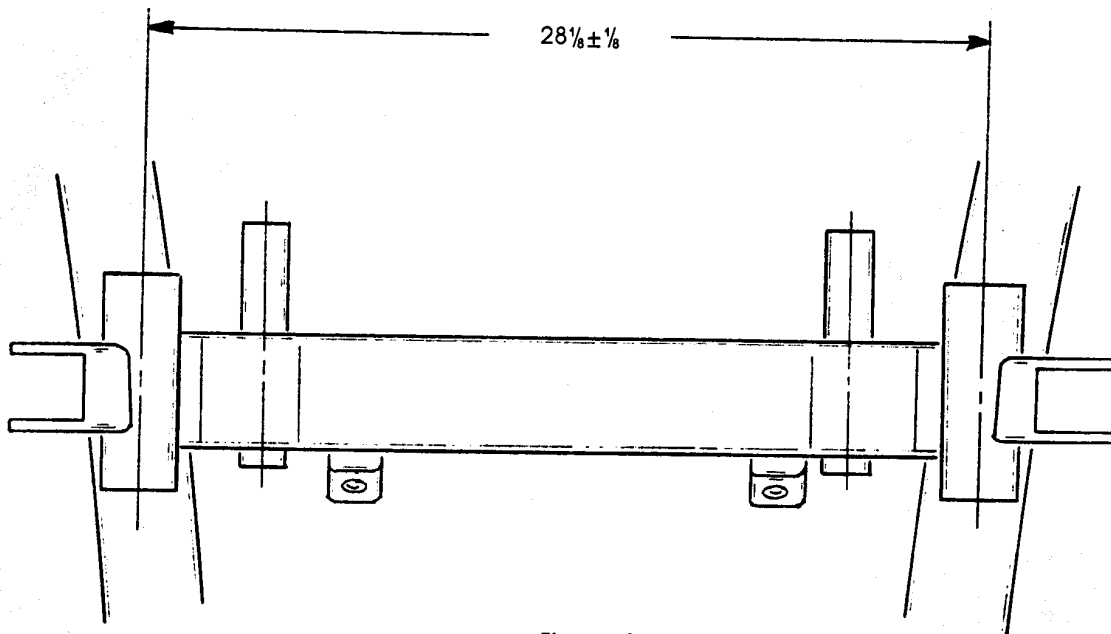

Figure 4



1-800-841-8188 Illinois (847) 487-0150

© HEIDTS Hot Rod Shop
IN-028