

## Installation for BMW M5 & M6 4-Door Sedans PN's-140511, 140566, 140582



**These instructions have been written to help you with the installation of your Borla Performance Exhaust System. Please read this document completely before beginning the installation of your system.**

**Please compare the parts in the box with the bill of materials provided to assure that you have all the parts necessary for this installation.**

**To ensure this part number fits your specific model year, please visit our website for the latest model year listings at [www.BORLA.com](http://www.BORLA.com).**

**Thank you for purchasing a Borla Performance Exhaust System.**

**Borla Performance Cat-Back™ Exhaust Systems (PN-140511, 140566, 140582) are designed for the BMW M5 & M6 4-Door Sedans, 4.4L V8 twin-turbocharged engine, automatic transmission.**

Borla Performance Industries recommends that an exhaust shop or professional after market parts installer perform the installation of this system. However, if you decide to perform the installation on your own it is recommended that two people are used. This installation should not be performed by one person due to the risk of injury. Ensure the installers use all under car safety precautions including eye protection.

***Please take time to read and understand the following...***

By installing your Borla Performance Exhaust System, you indicate that you have read this document and you agree with the terms stated below.

It is the responsibility of the purchaser to follow all installation instruction guidelines and safety procedures supplied with your Borla Performance Exhaust System.

Borla Performance Industries assumes no responsibility for damages occurring from misuse, abuse, improper installation, improper operation, lack of responsible care, or all previously stated reasons resulting from incompatibility with other manufacturer's products and/or systems.

Included with your Borla Performance Exhaust System is a warranty card. Please read it carefully before you begin any work on your vehicle. If you should have any questions regarding our warranty policy, installation, or any other matter pertaining to your new Borla Performance Exhaust System, please give us a call at the number provided on the warranty card.

**Minimum Required Tool List:**

**TOOLS:**

1. 3/8" Drive Ratchet
2. 3/8" Drive Extension 3"
3. 13mm, 14mm sockets
4. 15mm Deep Well Socket
5. Pry Bar

**SHOP SUPPLIES:**

- 1 Spray Lubricant

**Borla Performance - Bill of Materials**

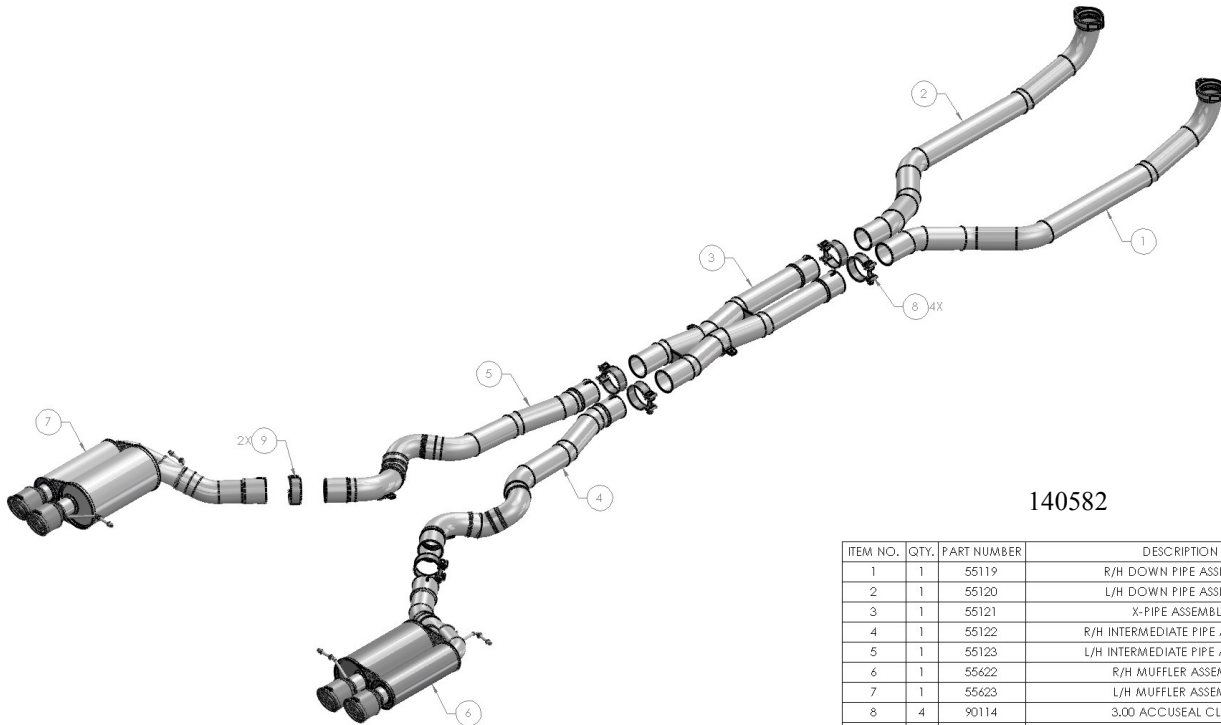

140582

ITEM NO.	QTY.	PART NUMBER	DESCRIPTION
1	1	55119	R/H DOWN PIPE ASSEMBLY
2	1	55120	L/H DOWN PIPE ASSEMBLY
3	1	55121	X-PIPE ASSEMBLY
4	1	55122	R/H INTERMEDIATE PIPE ASSEMBLY
5	1	55123	L/H INTERMEDIATE PIPE ASSEMBLY
6	1	55622	R/H MUFFLER ASSEMBLY
7	1	55623	L/H MUFFLER ASSEMBLY
8	4	90114	3.00 ACCUSEAL CLAMP
9	2	90179	S/S ACCUSEAL CLAMP Ø3.28 (MADE FROM 90114)

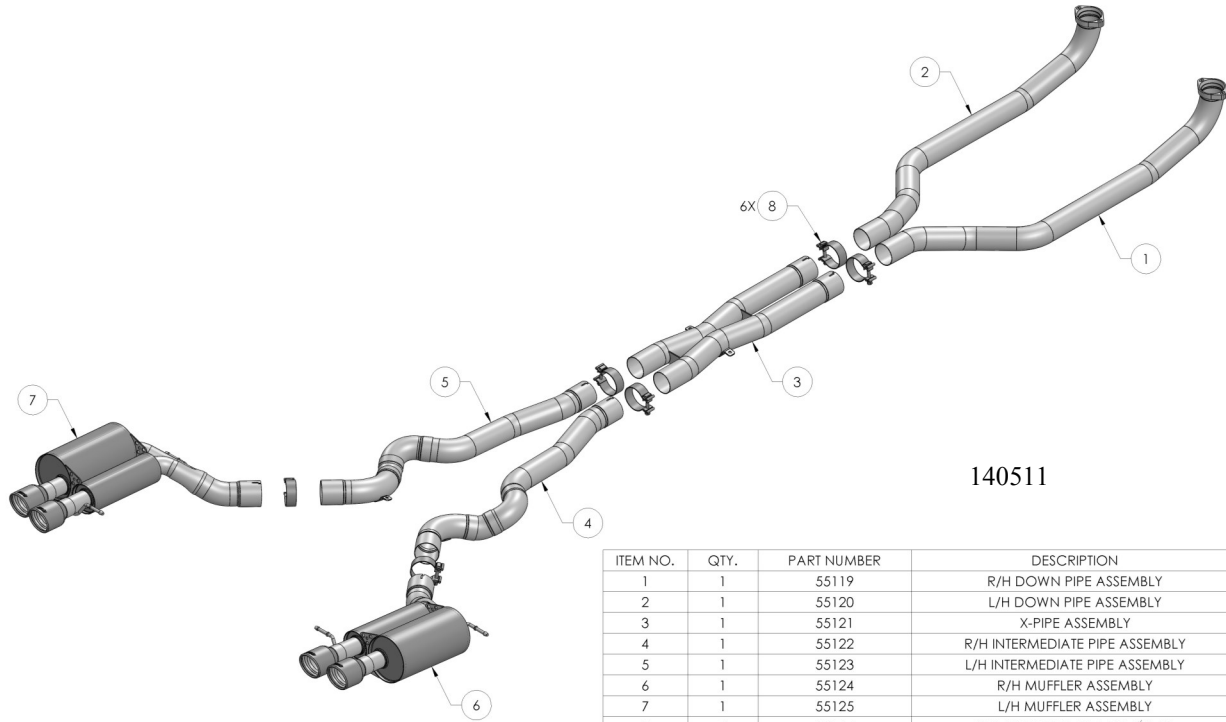

140511

ITEM NO.	QTY.	PART NUMBER	DESCRIPTION
1	1	55119	R/H DOWN PIPE ASSEMBLY
2	1	55120	L/H DOWN PIPE ASSEMBLY
3	1	55121	X-PIPE ASSEMBLY
4	1	55122	R/H INTERMEDIATE PIPE ASSEMBLY
5	1	55123	L/H INTERMEDIATE PIPE ASSEMBLY
6	1	55124	R/H MUFFLER ASSEMBLY
7	1	55125	L/H MUFFLER ASSEMBLY
8	6	90114	S/S ACCUSEAL CLAMP $\varnothing$ 3.00

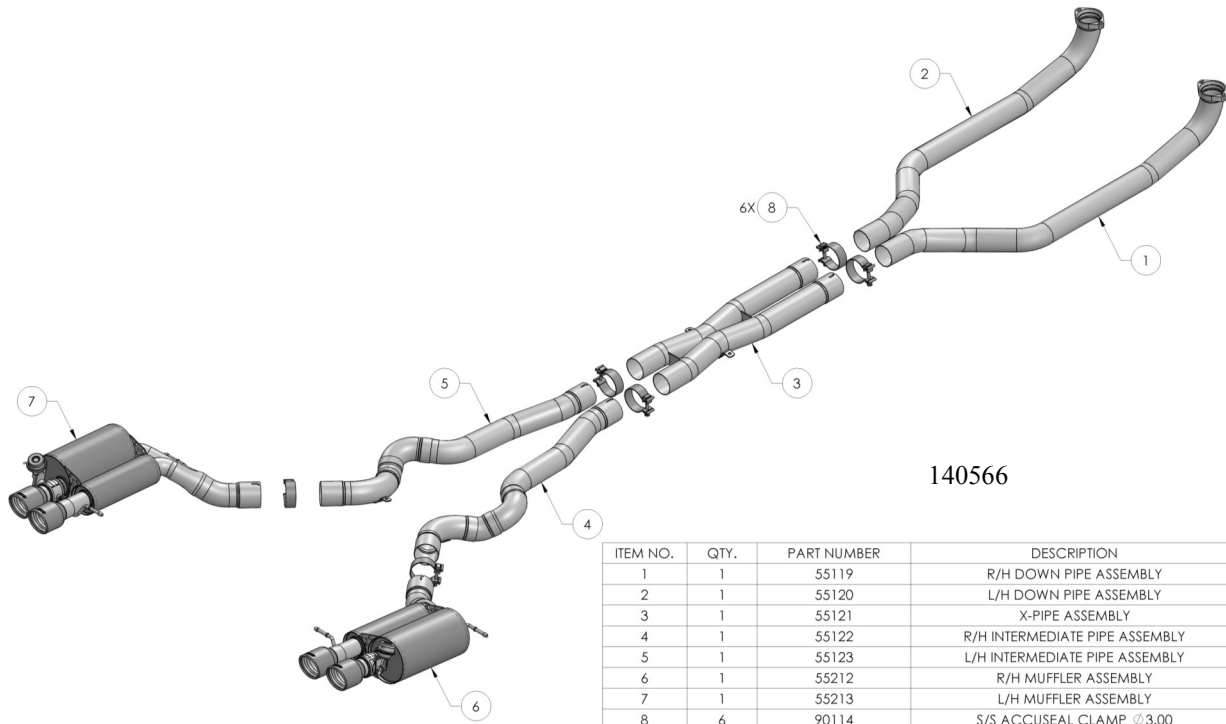

140566

ITEM NO.	QTY.	PART NUMBER	DESCRIPTION
1	1	55119	R/H DOWN PIPE ASSEMBLY
2	1	55120	L/H DOWN PIPE ASSEMBLY
3	1	55121	X-PIPE ASSEMBLY
4	1	55122	R/H INTERMEDIATE PIPE ASSEMBLY
5	1	55123	L/H INTERMEDIATE PIPE ASSEMBLY
6	1	55212	R/H MUFFLER ASSEMBLY
7	1	55213	L/H MUFFLER ASSEMBLY
8	6	90114	S/S ACCUSEAL CLAMP $\varnothing$ 3.00

**Caution!!!** *Never work on a hot exhaust system. Serious injury in the form of burns can result* If the vehicle has been in use and the exhaust system is hot, allow vehicle to cool for at least 1 hour. Always wear eye protection when working under any vehicle.

*Note: It is our recommendation that you use a hoist or hydraulic lift to facilitate the installation of your new Borla Performance Cat-Back™ Exhaust System.*

Taking all under car safety precautions, lift the vehicle using a hoist or hydraulic lift. Once this has been done, you may begin the removal of your old exhaust system from your vehicle.

*Note: Before removing the original exhaust system from your vehicle, please compare the parts you have received with the bill of materials provided on the previous page to assure that you have all the parts necessary for the installation of your new Borla Performance Cat-Back™ Exhaust System.*

## Original Exhaust System Removal

*Note: With a used vehicle, we suggest a penetrating spray lubricant to be applied liberally to all exhaust fasteners and allowing a significant period of time for the chemical to lubricate the threads before attempting to disassemble.*

1. Lubricate all the hangers and rubber isolators.
2. Loosen and remove (6) bolts and remove rear bracket as shown. **Keep factory hardware for reinstallation.** (See Figs. 1 & 2)
3. Loosen and remove center support as shown. **Keep factory hardware for reinstallation.** (See Fig. 3)
4. Loosen and remove single bolt of panel as shown. This allows cross-bracket to remain on exhaust for removal. **Keep factory hardware for reinstallation.** (See Fig. 4)
5. Remove left-side exhaust from vehicle. Remove band-clamp and tip assembly. Remove right-side exhaust from vehicle.

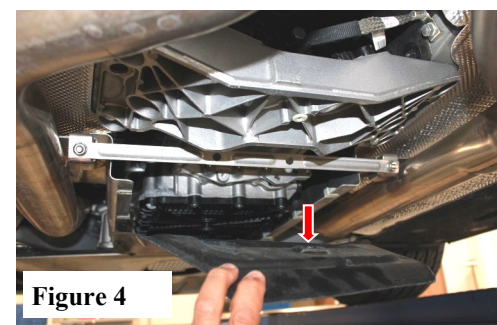
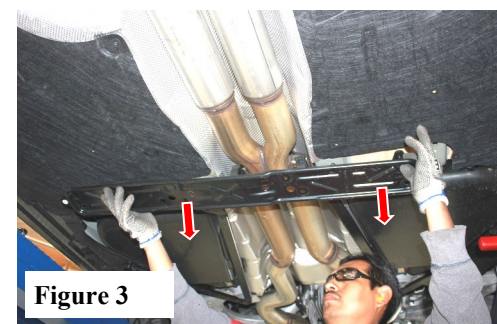
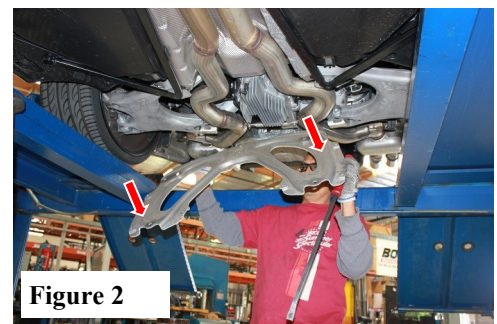
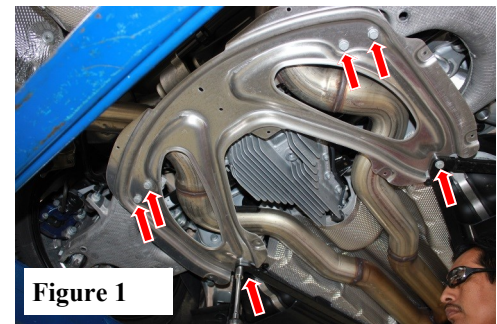

**Caution!!!** *Never work on a hot exhaust system. Serious injury in the form of burns can result* If the vehicle has been in use and the exhaust system is hot, allow vehicle to cool for at least 1 hour. Always wear eye protection when working under any vehicle.

*Note: It is our recommendation that you use a hoist or hydraulic lift to facilitate the installation of your new Borla Performance Cat-Back™ Exhaust System.*

Taking all under car safety precautions, lift the vehicle using a hoist or hydraulic lift. Once this has been done, you may begin the removal of your old exhaust system from your vehicle.

*Note: Before removing the original exhaust system from your vehicle, please compare the parts you have received with the bill of materials provided on the previous page to assure that you have all the parts necessary for the installation of your new Borla Performance Cat-Back™ Exhaust System.*

## Original Exhaust System Removal

*Note: With a used vehicle, we suggest a penetrating spray lubricant to be applied liberally to all exhaust fasteners and allowing a significant period of time for the chemical to lubricate the threads before attempting to disassemble.*

6. Remove exhaust flange bolts on front exhaust system. (See Fig. 5)
7. Support exhaust system with muffler stands before disconnecting exhaust from vehicle. (See Fig. 6)
8. Loosen and remove ground wire nut. **Keep factory hardware for reinstallation.** (See Fig. 7)

**140566 only: Disconnect Leftside & Rightside vacuum hoses to rear valves.**

9. Remove rear cross-brace. **Keep factory hardware for reinstallation.** (See Fig. 8)

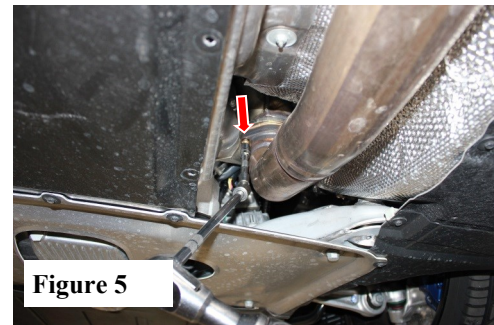

Figure 5



Figure 6

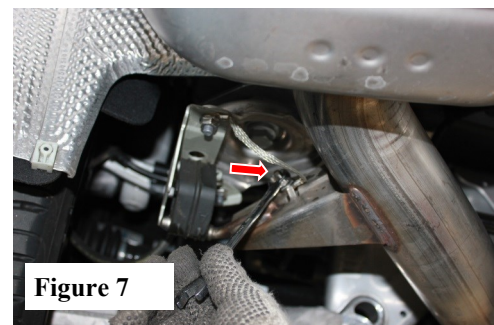

Figure 7

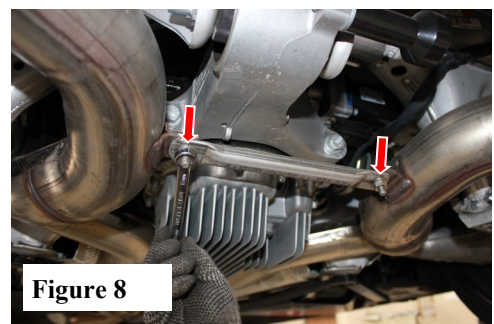

Figure 8

**Caution!!!** *Never work on a hot exhaust system. Serious injury in the form of burns can result* If the vehicle has been in use and the exhaust system is hot, allow vehicle to cool for at least 1 hour. Always wear eye protection when working under any vehicle.

*Note: It is our recommendation that you use a hoist or hydraulic lift to facilitate the installation of your new Borla Performance Cat-Back™ Exhaust System.*

Taking all under car safety precautions, lift the vehicle using a hoist or hydraulic lift. Once this has been done, you may begin the removal of your old exhaust system from your vehicle.

*Note: Before removing the original exhaust system from your vehicle, please compare the parts you have received with the bill of materials provided on the previous page to assure that you have all the parts necessary for the installation of your new Borla Performance Cat-Back™ Exhaust System.*

## Original Exhaust System Removal

*Note: With a used vehicle, we suggest a penetrating spray lubricant to be applied liberally to all exhaust fasteners and allowing a significant period of time for the chemical to lubricate the threads before attempting to disassemble.*

9. Remove all hangers from rubber isolators. (See Fig. 9)
10. 2-people are needed to remove exhaust from vehicle. Carefully drop and slide exhaust system as shown. (See Figs 10 & 11)
11. Factory exhaust removed from vehicle. (See Fig. 12)
12. Loosen and remove factory X-pipe mounting hardware. This will be re-used in your new Borla cat-back.

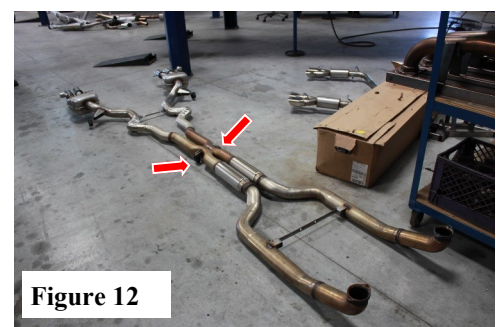
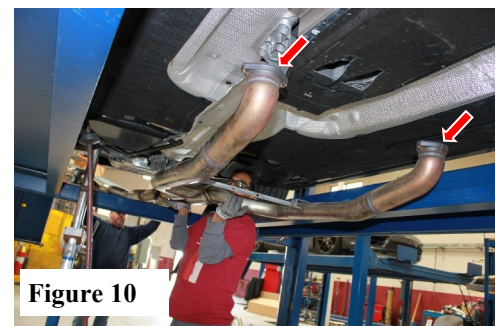
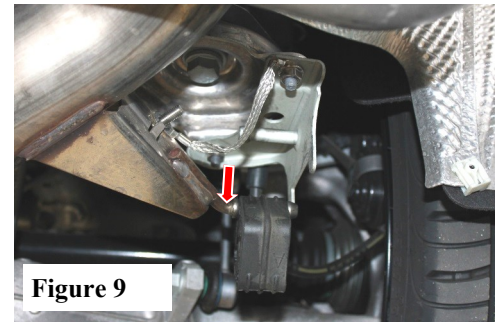

**Caution!!!** *Never work on a hot exhaust system. Serious injury in the form of burns can result* If the vehicle has been in use and the exhaust system is hot, allow vehicle to cool for at least 1 hour. Always wear eye protection when working under any vehicle.

*Note: It is our recommendation that you use a hoist or hydraulic lift to facilitate the installation of your new Borla Performance Cat-Back™ Exhaust System.*

Taking all under car safety precautions, lift the vehicle using a hoist or hydraulic lift. Once this has been done, you may begin the removal of your old exhaust system from your vehicle.

*Note: Before removing the original exhaust system from your vehicle, please compare the parts you have received with the bill of materials provided on the previous page to assure that you have all the parts necessary for the installation of your new Borla Performance Cat-Back™ Exhaust System.*

## Borla Performance Exhaust System Installation

1. Refer to page 2 drawing for orientation of components.
2. Position LH Downpipe Assembly and insert flange into bolts. Replace hardware on flanges. (See Fig. 13)
3. Repeat step 13 to RH Downpipe Assembly.
4. Insert removed OE hardware to X-Pipe Assembly as shown (reference page 5, step 12).
5. Place X-Pipe Assembly over installed DP Assemblies as shown. **DO NOT TIGHTEN.** (See Figs. 14 & 15)
6. Reinstall center support using factory hardware. (See Fig. 16)

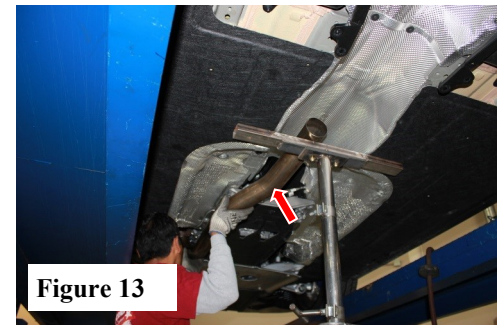

Figure 13

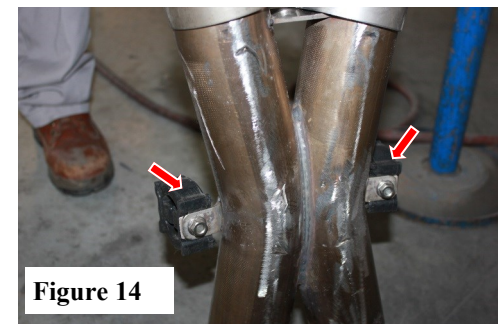

Figure 14

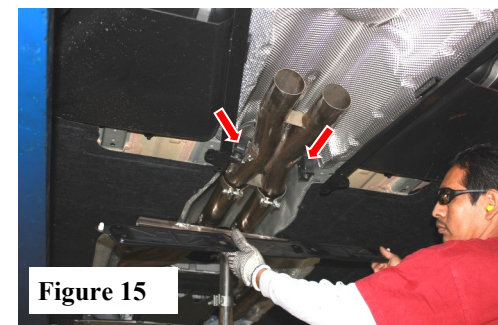

Figure 15

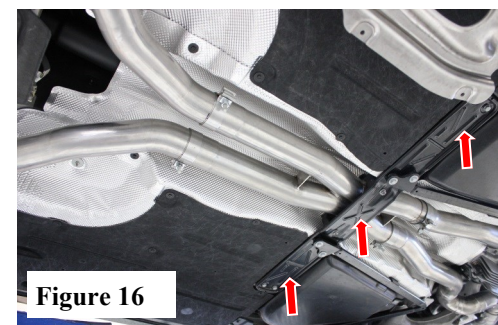

Figure 16

**\*\*\*\*\* Please refer to factory-recommended bolt torque specifications when tightening original hardware \*\*\*\*\***

**NOTE:** *When you first start your vehicle after the installation of your new Borla Performance Exhaust System, there may be some smoke and fumes coming from the system. This is a protective oil based coating used in the manufacturing of mandrel bent performance exhaust tubing. This is not a problem and will disappear within a very short period of time after the exhaust has reached normal operating temperatures.*

**Caution!!!** *Never work on a hot exhaust system. Serious injury in the form of burns can result* If the vehicle has been in use and the exhaust system is hot, allow vehicle to cool for at least 1 hour. Always wear eye protection when working under any vehicle.

*Note: It is our recommendation that you use a hoist or hydraulic lift to facilitate the installation of your new Borla Performance Cat-Back™ Exhaust System.*

Taking all under car safety precautions, lift the vehicle using a hoist or hydraulic lift. Once this has been done, you may begin the removal of your old exhaust system from your vehicle.

*Note: Before removing the original exhaust system from your vehicle, please compare the parts you have received with the bill of materials provided on the previous page to assure that you have all the parts necessary for the installation of your new Borla Performance Cat-Back™ Exhaust System.*

## Borla Performance Exhaust System Installation

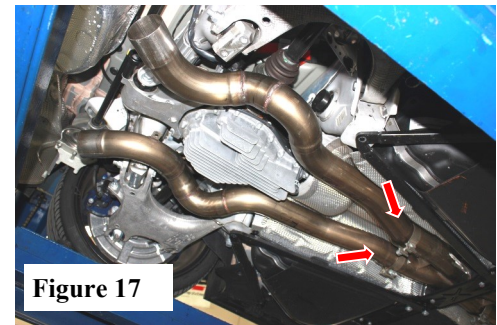

Figure 17

6. Place a clamp on front of L/H Intermediate Pipe Assembly and insert pipe into X-Pipe Assembly. Repeat for R/H Intermediate Pipe. (See Fig. 17)

7. Install factory rear cross-brace using factory hardware. (See Fig. 18)

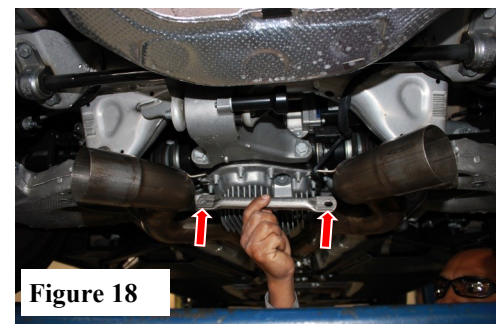

Figure 18

8. Place a clamp on front of L/H Muffler Assembly. Carefully insert hangars into rubber isolators. DO NOT TIGHTEN CLAMP. (See Fig. 19 & 20)

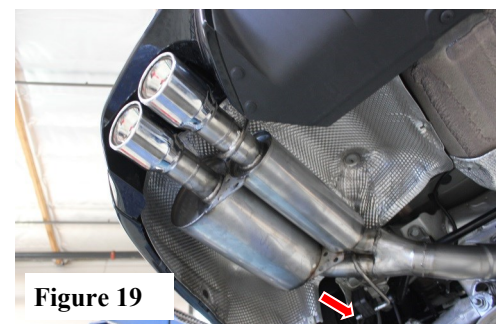

Figure 19

**\*\*\*\*\* Please refer to factory-recommended bolt torque specifications when tightening original hardware \*\*\*\*\***

**NOTE:** *When you first start your vehicle after the installation of your new Borla Performance Exhaust System, there may be some smoke and fumes coming from the system. This is a protective oil based coating used in the manufacturing of mandrel bent performance exhaust tubing. This is not a problem and will disappear within a very short period of time after the exhaust has reached normal operating temperatures.*

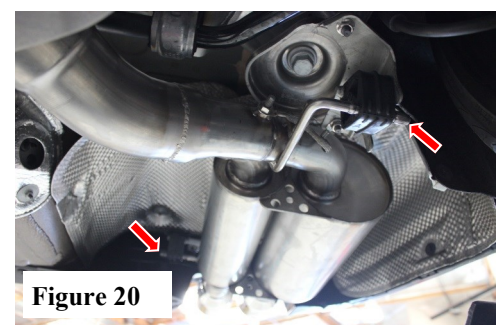

Figure 20



**Caution!!!** *Never work on a hot exhaust system. Serious injury in the form of burns can result* If the vehicle has been in use and the exhaust system is hot, allow vehicle to cool for at least 1 hour. Always wear eye protection when working under any vehicle.

*Note: It is our recommendation that you use a hoist or hydraulic lift to facilitate the installation of your new Borla Performance Cat-Back™ Exhaust System.*

Taking all under car safety precautions, lift the vehicle using a hoist or hydraulic lift. Once this has been done, you may begin the removal of your old exhaust system from your vehicle.

*Note: Before removing the original exhaust system from your vehicle, please compare the parts you have received with the bill of materials provided on the previous page to assure that you have all the parts necessary for the installation of your new Borla Performance Cat-Back™ Exhaust System.*

## Borla Performance Exhaust System Installation

9. Place a clamp on front of R/H Muffler Assembly. Carefully insert hangars into rubber isolators. DO NOT TIGHTEN CLAMP. (See Fig. 21 & 22)
10. Install rear bracket using factory hardware. (See Fig. 23)
11. Re-connect ground wire to exhaust (reference page 4, step 7).
12. **PN-140566 only: Re-connect vacuum hose to L & R valves.**
13. Start tightening exhaust hardware at the front flanges to X-Pipe clamps to Intermediate Pipe clamps to Rear Muffler clamps. Check alignment of tips and tighten clamp hardware 35 ft. lbs. torque.

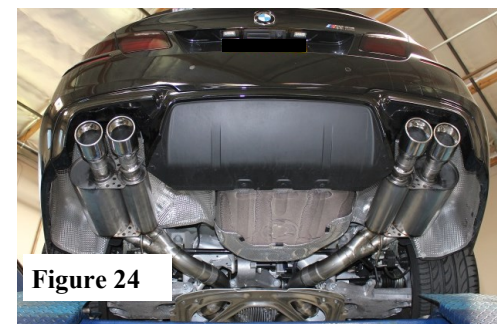
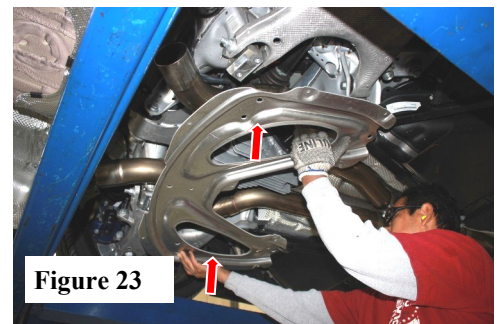
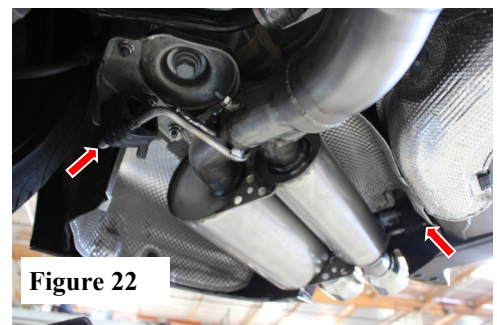

**\*\*\*\*\* Please refer to factory-recommended bolt torque specifications when tightening original hardware \*\*\*\*\***

**NOTE: When you first start your vehicle after the installation of your new Borla Performance Exhaust System, there may be some smoke and fumes coming from the system. This is a protective oil based coating used in the manufacturing of mandrel bent performance exhaust tubing. This is not a problem and will disappear within a very short period of time after the exhaust has reached normal operating temperatures.**