





1998.5-2002 5.9 Dodge Cummins **Positive Air Shutoff**







P/N#	1036719
P/N#	1036719-M

PLEASE READ ALL INSTRUCTIONS BEFORE INSTALLATION

KIT CONTENTS:

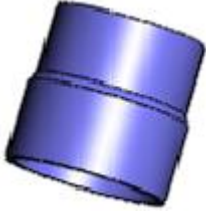
Please check to make sure that you have all the parts listed in this kit **before** you start the disassembly of your truck.

1036719 Kit Contents		
1302300	1302240	1405404
		
<i>Air Shutoff Valve</i>	<i>Wiring Harness</i>	<i>3-3.25" Silicone Boot</i>
Qty: 1	Qty: 1	Qty: 2
1302261P	1405211	1407030
		
<i>Intake Pipe</i>	<i>0325 Clamps</i>	<i>0350 Clamps</i>
Qty: 1	Qty: 2	Qty: 2
1800060	1306719	1302285
		
<i>Velcro strips</i>	<i>5.9 Electronic Module</i>	<i>Solder</i>
Qty: 2 x 4"	Qty: 1	Qty: 5"

1036719-M Kit Contents		
1302300	1302249	1405404
		
<i>Air Shutoff Valve</i>	<i>Wiring Harness</i>	<i>3-3.25" Silicone Boot</i>
Qty: 1	Qty: 1	Qty: 2
1302261P	1405211	1407030
		
<i>Intake Pipe</i>	<i>0325 Clamps</i>	<i>0350 Clamps</i>
Qty: 1	Qty: 2	Qty: 2

WELCOME

Thank you for purchasing a BD positive air shutoff. This manual is divided into different areas to assist you with your installation and operation of your positive Air shutoff.

This product is a safety product and should be tested often.

Installation should occur on a vehicle properly secured to prevent rolling.

TABLE OF CONTENTS

1036719 Kit Contents	2
1036719-M Kit Contents	3
REQUIRED TOOLS.....	4
MAINTENANCE.....	5
INSTALLATION with OVER SPEED ELECTRONICS (1036719).....	5
INSTALLATION without OVER SPEED ELECTRONICS (1036719-M).....	14
WIRING DIAGRAM with OVER SPEED ELECTRONICS (1036719)	20
WIRING DIAGRAM without OVER SPEED ELECTRONICS (1036719-M)	21
RESETTING THE VALVE.....	22
SETUP, TESTING AND VERIFICATION with OVERSPEED ELECTRONICS.....	23
Automatic Mode (Pre Configured RPM)	23
Manual Mode (User Configured RPM)	25
TESTING FLOW CHART with OVER SPEED ELECTRONICS	28
TESTING FLOW CHART without OVER SPEED ELECTRONICS	29
LED OPERATION.....	30

REQUIRED TOOLS

- Frequency/Voltmeter (Optional)
- Drill
- 1/8" Drill Bit
- 1/2" Unibit
- Electrical Tape
- Soldering Iron
- Air or Manual Ratchet
- 7/16", 1/2" Sockets
- Wire Strippers
- Wire Cutters

BD Engine Brake Inc.

Plant Address: 33541 MacLure Rd. Abbotsford, BC, Canada V2S 7W2

U.S. Shipping Address: 88-446 Harrison St, Sumas, WA 98295 U.S. Mailing Address: P.O. Box 231, Sumas, WA 98295

Phone: 604-853-6096 | Fax: 604-853-8749 | Internet: www.bd-power.com

MAINTENANCE

No maintenance is needed other than check to make sure the valve is acting correctly. Please see the testing section later in the manual for the correct procedure.

INSTALLATION with OVER SPEED ELECTRONICS (1036719)

VEHICLE SHOULD BE SAFELY SECURED BEFORE INSTALLATION.

1. Block the wheels of the vehicle to prevent the vehicle from rolling.

Open the hood.

2. Remove driver's side charge air cooler (CAC) pipe and upper silicone boot using a 7/16" socket and ratchet.

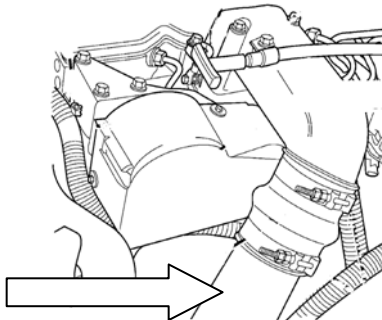
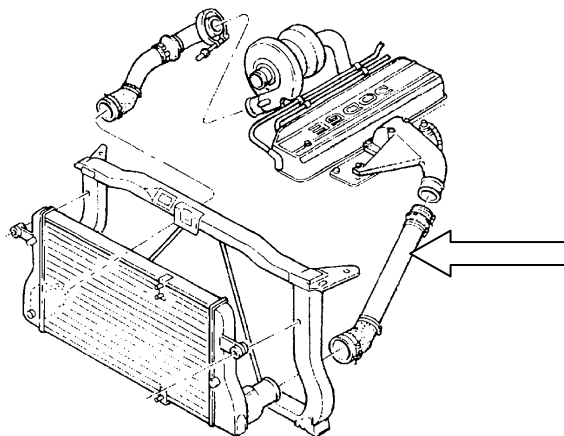

BD Engine Brake Inc.

Plant Address: 33541 MacLure Rd. Abbotsford, BC, Canada V2S 7W2

U.S. Shipping Address: 88-446 Harrison St, Sumas, WA 98295 U.S. Mailing Address: P.O. Box 231, Sumas, WA 98295

Phone: 604-853-6096 | Fax: 604-853-8749 | Internet: www.bd-power.com

- 3. Install the new CAC pipe (#1302261P) first, then install air shutoff valve assembly.

To ease installation, have the two provided boots pre-installed on the air shutoff valve prior to installation.

Use the 0350 clamps (#1407030) to secure the connection closest to the shutoff valve. While using the 0325 clamps (#1405211) to secure the boot to pipe connection.

Torque the clamps with a 1/2" socket unit the spring bottoms out.

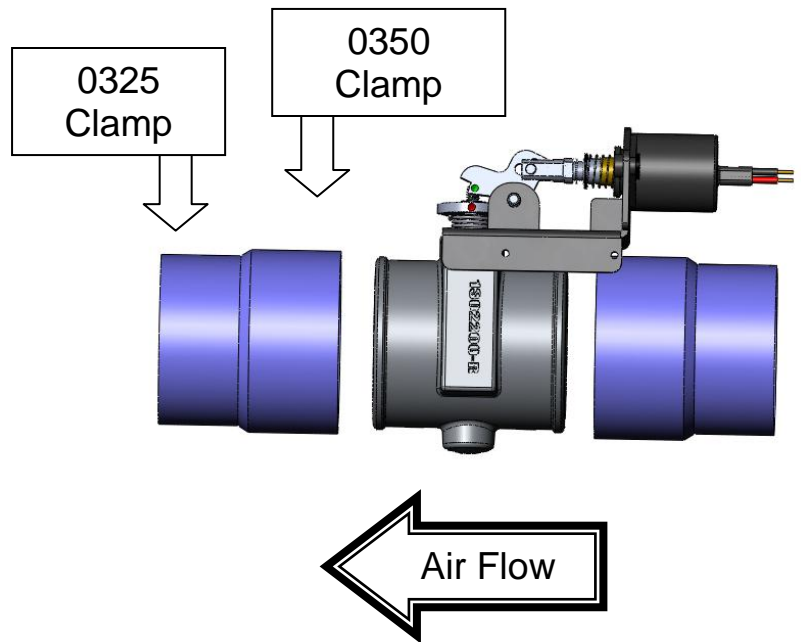
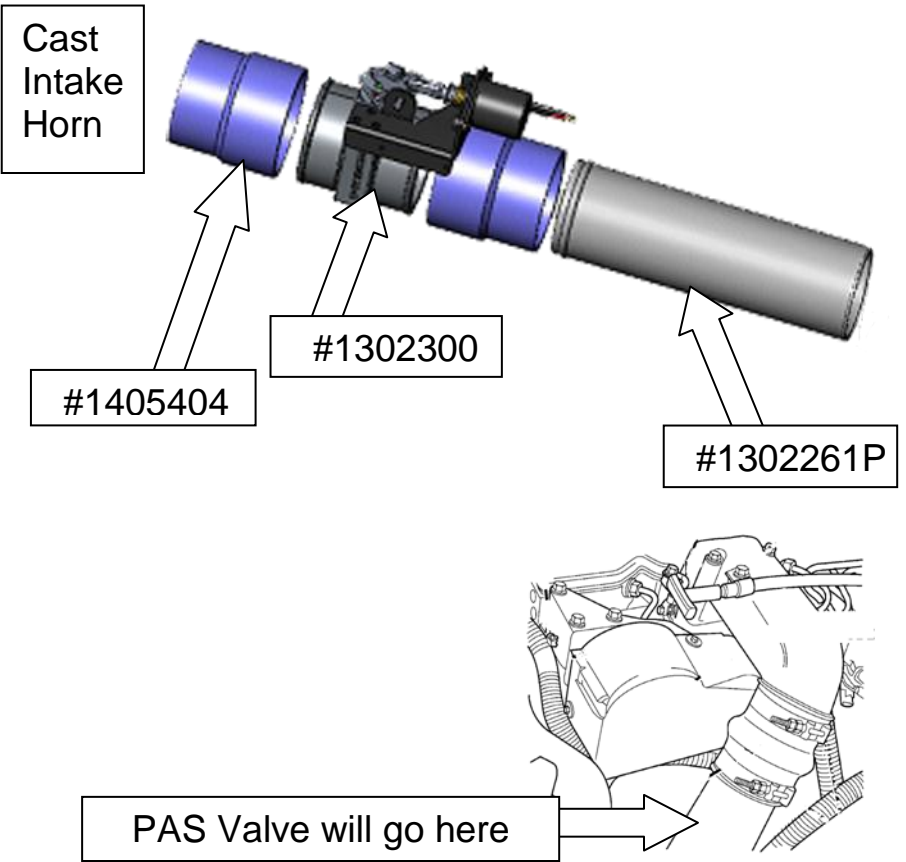

4. Lay out supplied harness over top of the driver's side of the engine.

You will then need to route the switch wires through the firewall (note you will need to remove the switch from the harness to accomplish this).

Choose a highly visible location for the switch and mount it to the dash.

Using a 1/8" drill, drill a pilot hole in the location you have selected for the switch to be mounted.

Finally using a 1/2" UNIBIT drill bit, drill an exact 1/2" round hole.

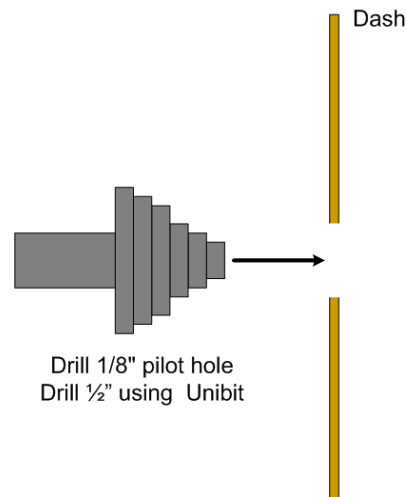
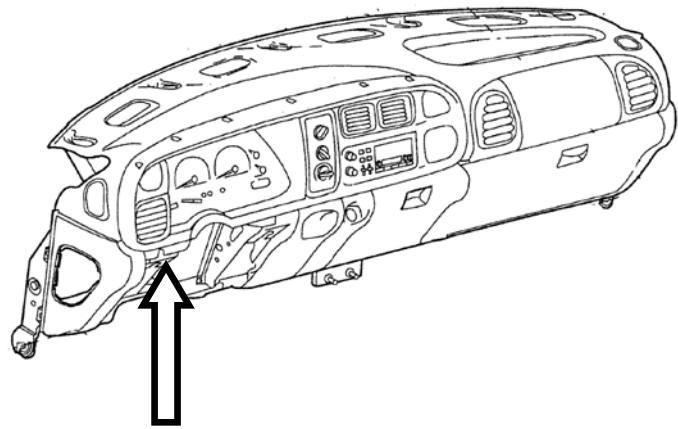

5. Once you have the mounting hole drilled, insert the switch from the backside.

Reinstall the correct wires to the correct switch terminals.

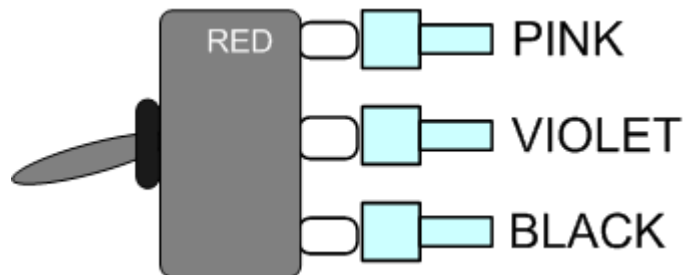

6. Mount the switch so that the groove on thread boss is facing down.

Adjust the HEX washer/nut so that the switch threads do not protrude an unsightly amount.

Then apply the supplied sticker and finally install the round plastic nut.

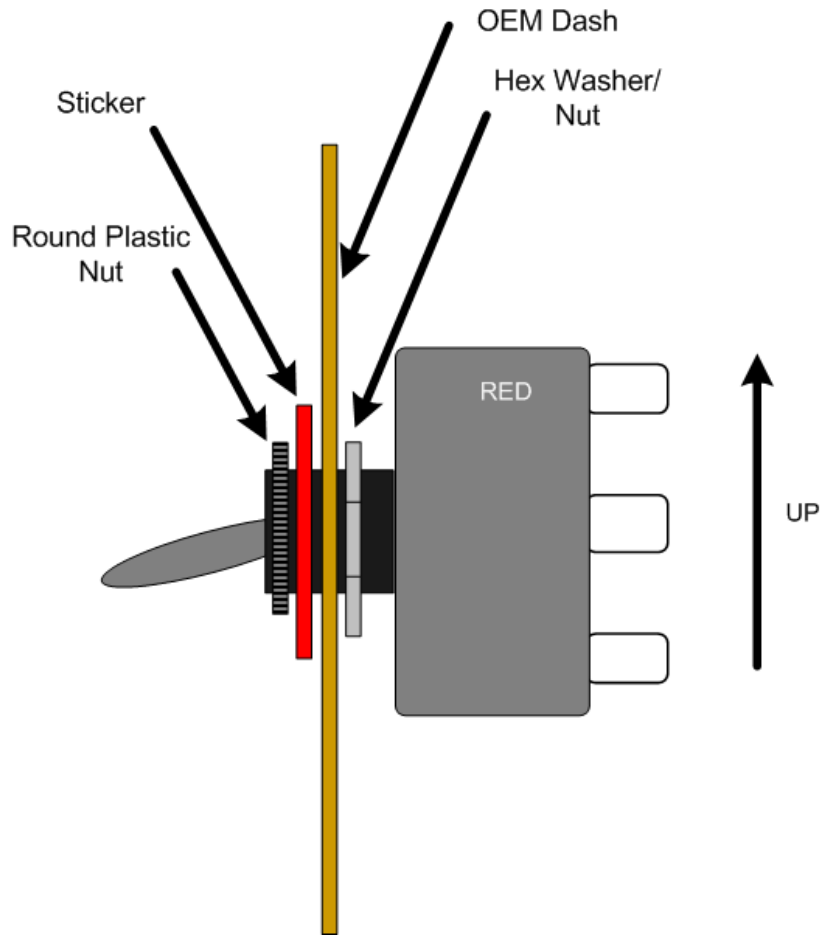

7. Locate and connect the weather pack connector on the wiring harness to the solenoid on the PAS valve.

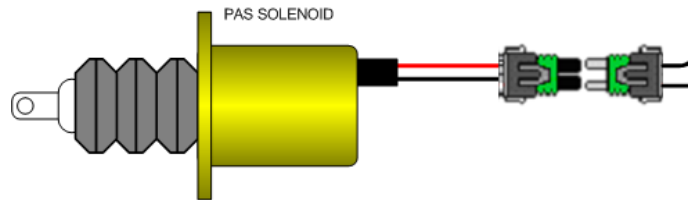

- 8. On the driver's side of the engine near the VP44 injection pump locate the CAM position sensor.

Once you have found the sensor locate the **GREY** wire in the wiring harness.

This **GREY** wire is routed down to the ECM on the side of the engine to pin 17.

**CMP Grey Wire (Pin
Sensor 17 ECM)**

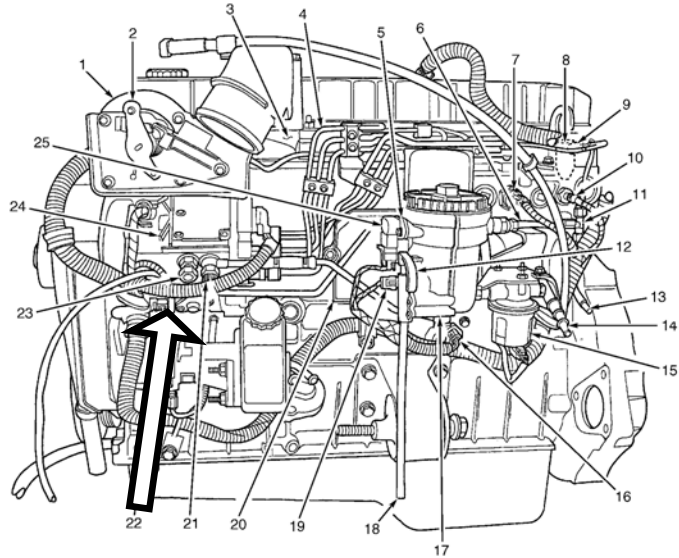

20. Engine Control Module (ECM)
22. Camshaft Position (CMP) Sensor
24. Fuel Injection Pump

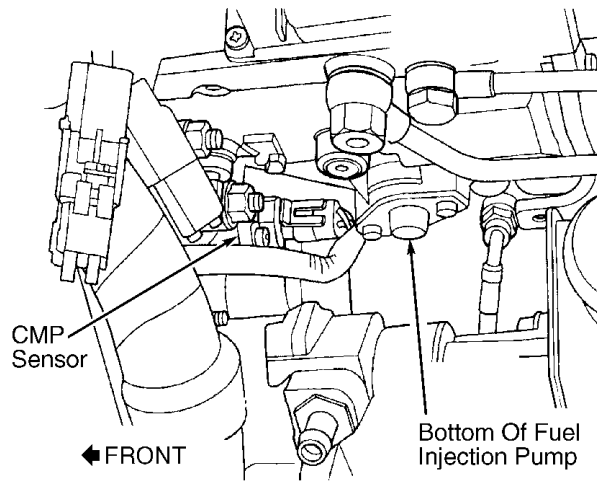

9. Being that the RPM signal is critical you will need to solder the connection.

Using wire strippers create a 1" window/gap in insulation of the wire.

Then strip about 1" of insulation of the RPM signal wire of the BLUE wire from the PAS wiring harness.

Wrap the copper wire around the factory RPM signal wire and solder this connection.

Then use electrical tape to wrap this connection so that it is water tight.

You can also cut the factory crank signal wire and use heat shrink tubing if you would like.

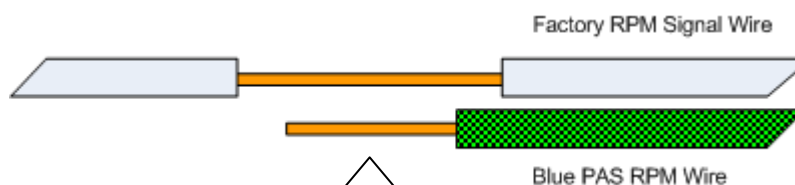

Solder the connection and then wrap and seal with electrical tape

10. Next on the wiring harness connection the BLACK and RED wires to the respective battery connections (Driver's Side Battery).

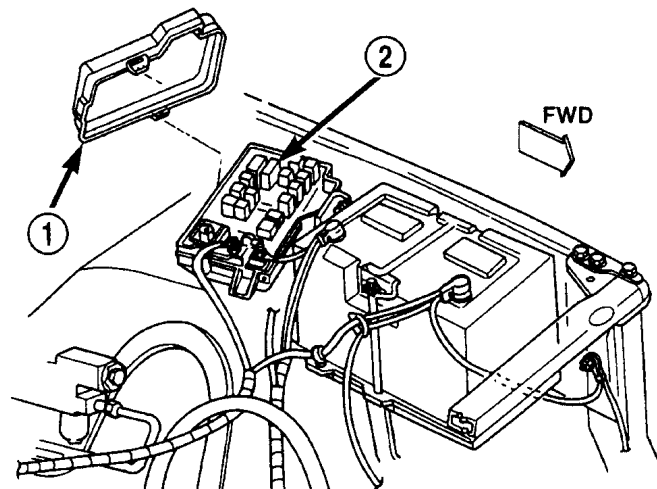
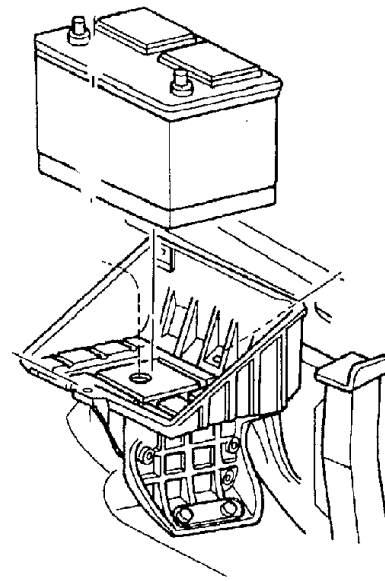

- 1 - COVER
- 2 - POWER DISTRIBUTION CENTER

G00330742

11. For the last connection you will need to locate ignition power. This will control power the automatic over speed control box LED switch. Note that they unit can still be activated manually with the switch at any time.

Locate the junction box located inside the cab on the driver's side.

Locate appropriate fused ignition power circuit (see table below). Install fuse tapper on to fuse, reinstall fuse. Connect yellow lead wire with flag connector to this new connection. Route wire out of fuse box and close lid.

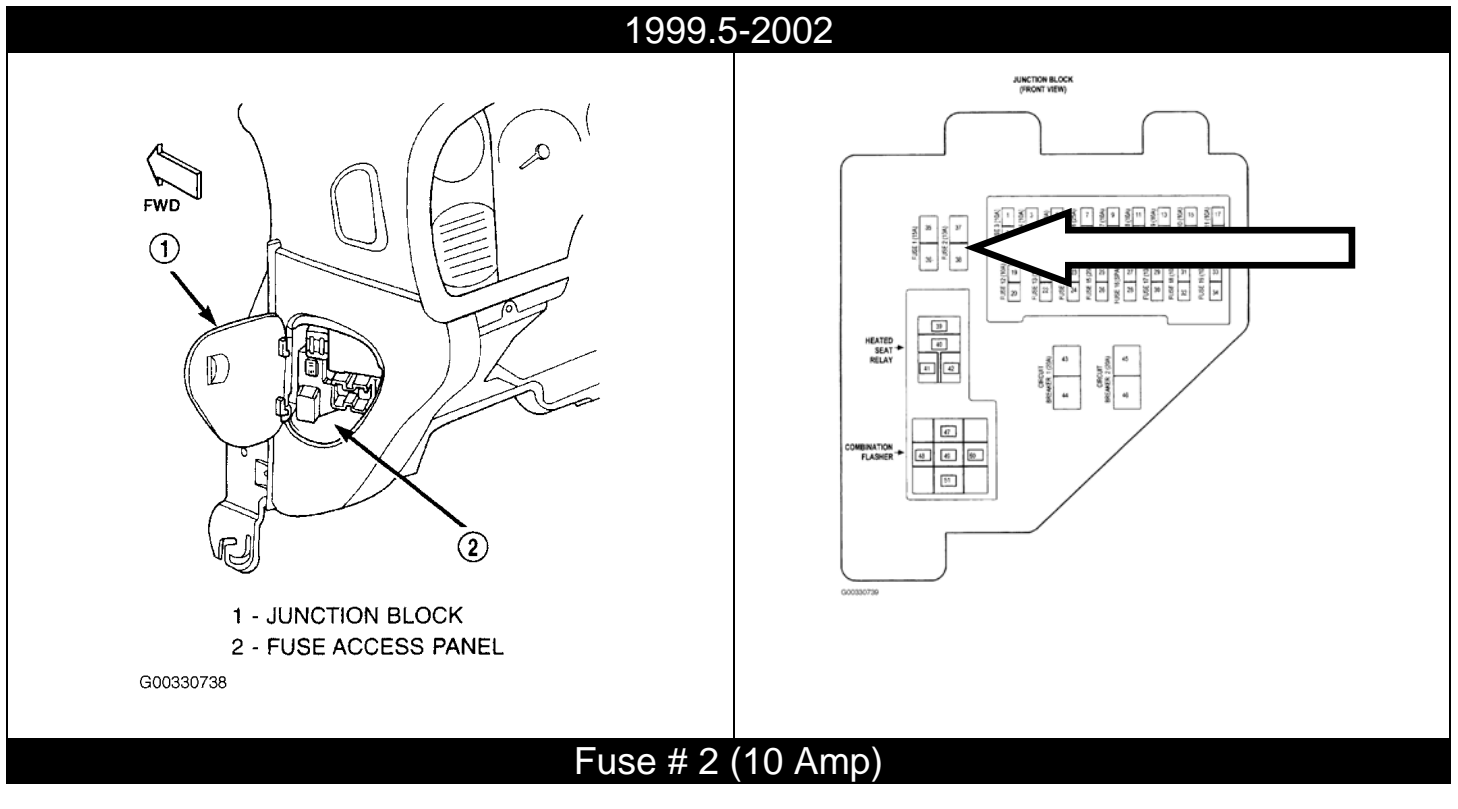

12. With the fuse box (PDC) closed, mount the electronic control module on top of it using the supplied Velcro. Connect harness to electronic control module.

Be sure to clean both surfaces with rubbing alcohol before apply velcro.

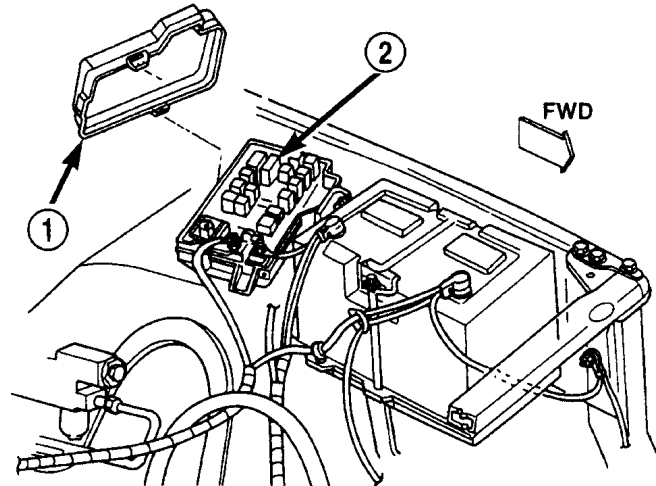

1 - COVER
2 - POWER DISTRIBUTION CENTER

G00330742

13. Double check all wiring connections and ensure wires are routed away from any heat sources and moving parts.

INSTALLATION without OVER SPEED ELECTRONICS (1036719-M)



VEHICLE SHOULD BE SAFELY SECURED BEFORE INSTALLATION.

1. Block the wheels of the vehicle to prevent the vehicle from rolling.

Open the hood.

2. Remove driver's side charge air cooler (CAC) pipe and upper silicone boot using a 7/16" socket and ratchet.

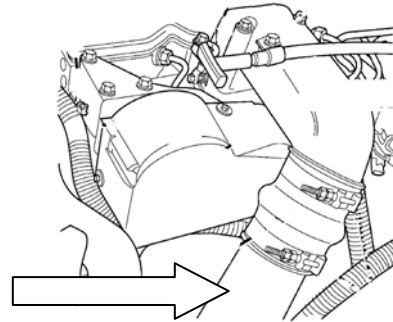
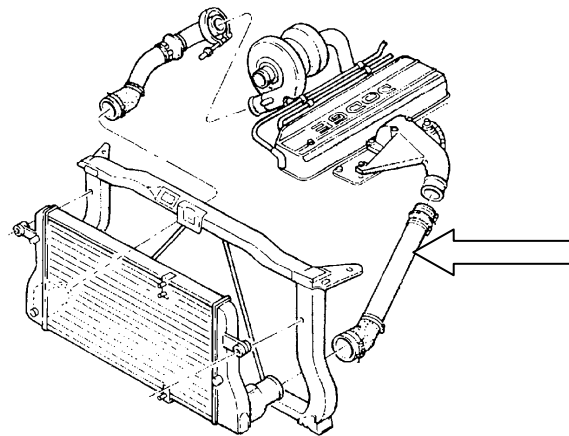

INSTALLATION without OVER SPEED ELECTRONICS

- 3. Install the new CAC pipe (#1302261P) first, and then install air shutoff valve assembly.

To ease installation, have the two provided boots pre-installed on the air shutoff valve prior to installation.

Use the 0350 clamps (#1407030) to secure the connection closest to the shutoff valve. While using the 0325 clamps (#1405211) to secure the boot to pipe connection.

Torque the clamps with a 1/2" socket unit the spring bottoms out.

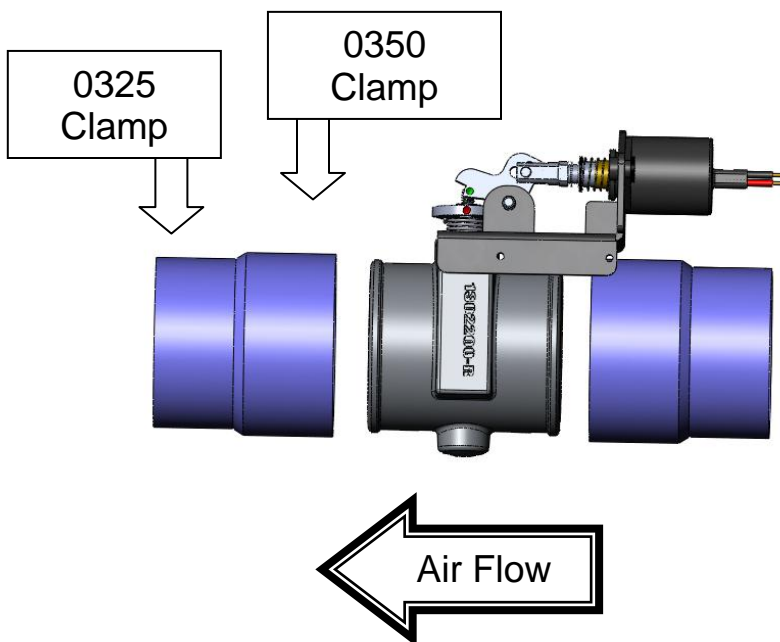
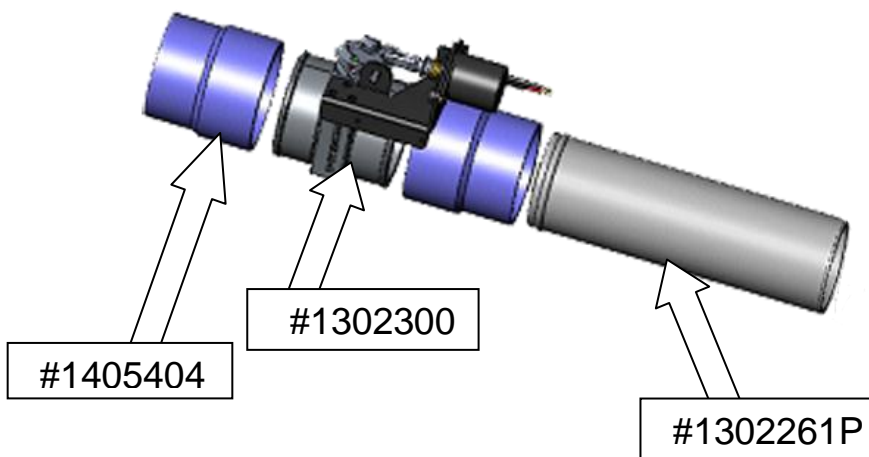

4. Lay out supplied harness over top of the driver's side of the engine.

Locate and connect the weather pack connector on the wiring harness to the solenoid on the PAS valve.

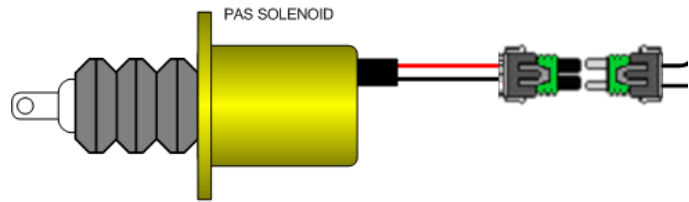

5. You will then need to route the switch wires through the firewall choosing a highly visible location for the switch and mount it to the dash.

NOTE: you may need to trim the switch wires to length once you have located where the switch is to be mounted.

Using a 1/8" drill, drill a pilot hole in the location you have selected for the switch to be mounted.

Finally using a 1/2" UNIBIT drill bit, drill an exact 1/2" round hole.

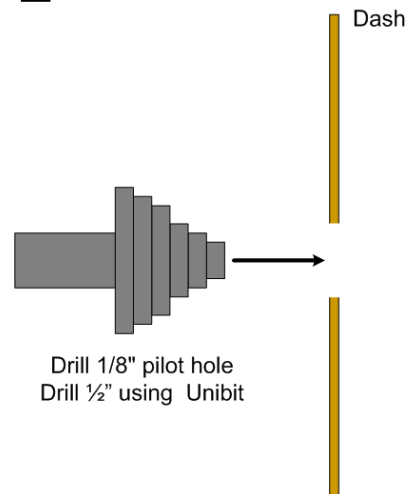
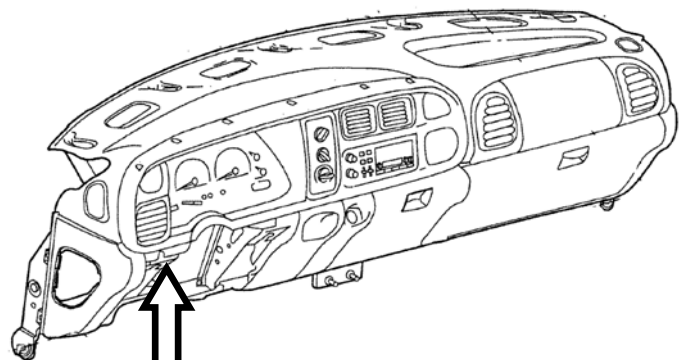

6. Once you have the mounting hole drilled, crimp the switch connectors to the switch wires and install the correct wires to the correct switch terminals then insert the switch into the dash from the backside.

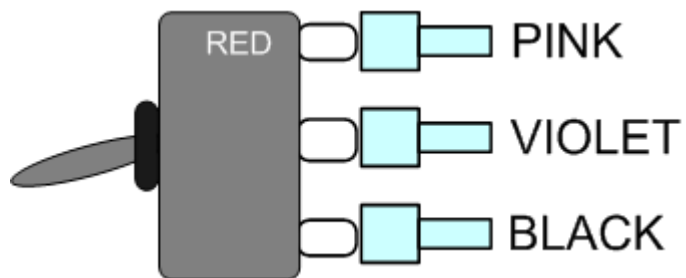

7. Mount the switch so that the groove on thread boss is facing down.

Adjust the HEX washer/nut so that the switch threads do not protrude an unsightly amount.

Then apply the supplied sticker and finally install the round plastic nut.

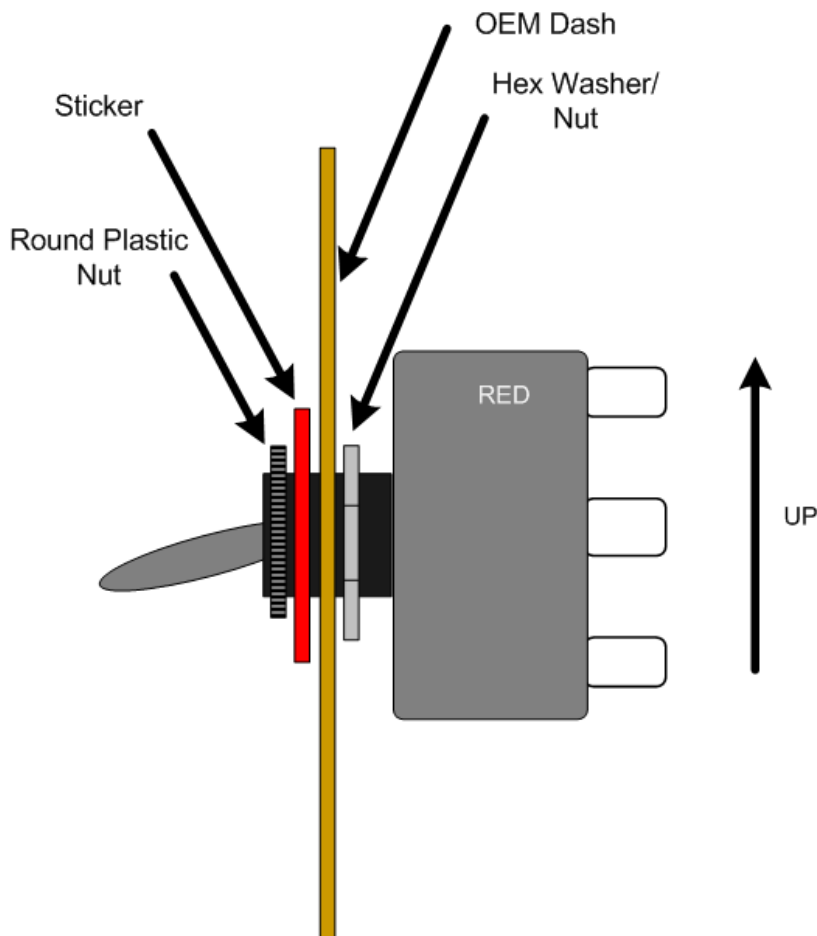

INSTALLATION without OVER SPEED ELECTRONICS

- 8. Next trim the wires to length and crimp the ring terminals to the BLACK and RED wires to connect to the respective battery connections. (Drivers side only).

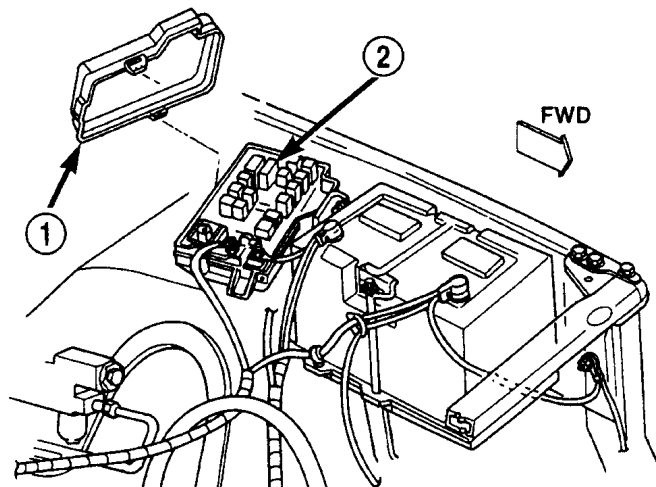
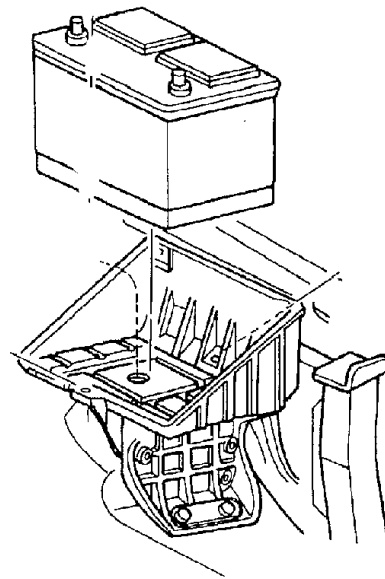

1 - COVER
2 - POWER DISTRIBUTION CENTER

G00330742

9. For the last connection you will need to locate ignition power.

Locate the junction box located inside the cab on the driver's side.

Locate appropriate fused ignition power circuit (see table below). Install fuse taper on to fuse, reinstall fuse. Trim the pink wire to length and crimp the flag connector to the wire and connect the pink lead wire with flag connector to this new connection. Route wire out of fuse box and close lid.

1999.5-2002

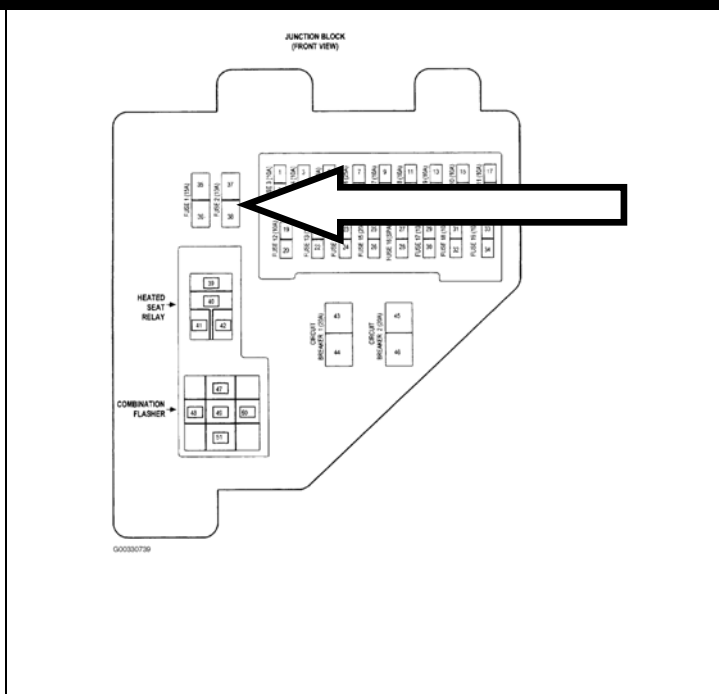
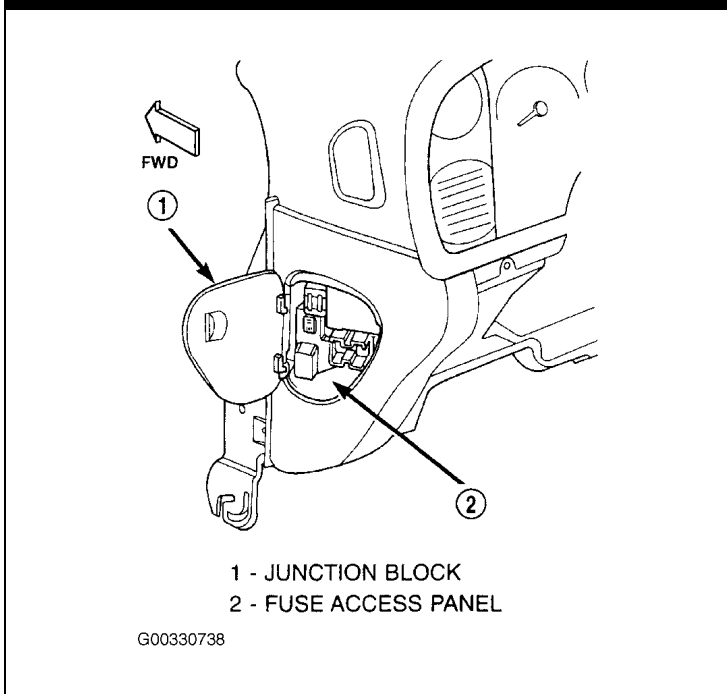

Fuse # 2 (10 Amp)

10. Double check all wiring connections and ensure wires are routed away from any heat sources and moving parts. Then install the loom with the supplied tee connector and clips for the loom ends and continue to the testing flow chart without over speed electronics in this manual.

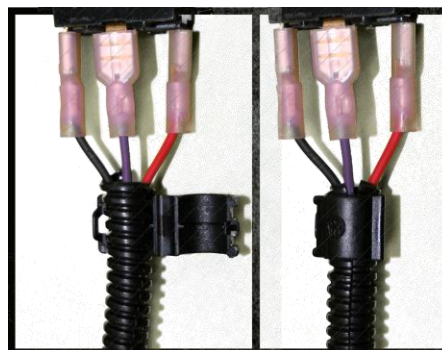
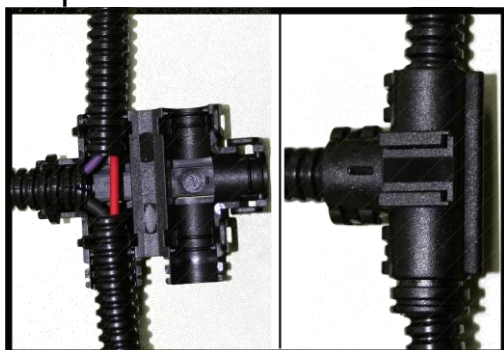

INSTALLATION without OVER SPEED ELECTRONICS

WIRING DIAGRAM with OVER SPEED ELECTRONICS (1036719)

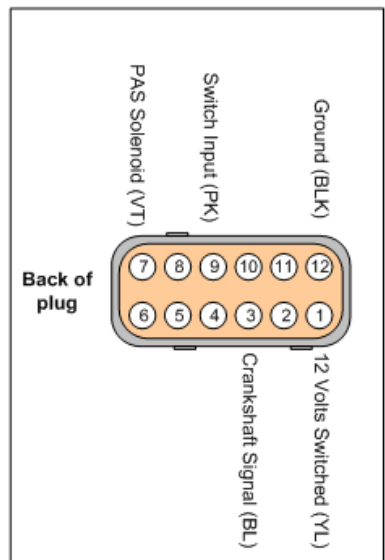
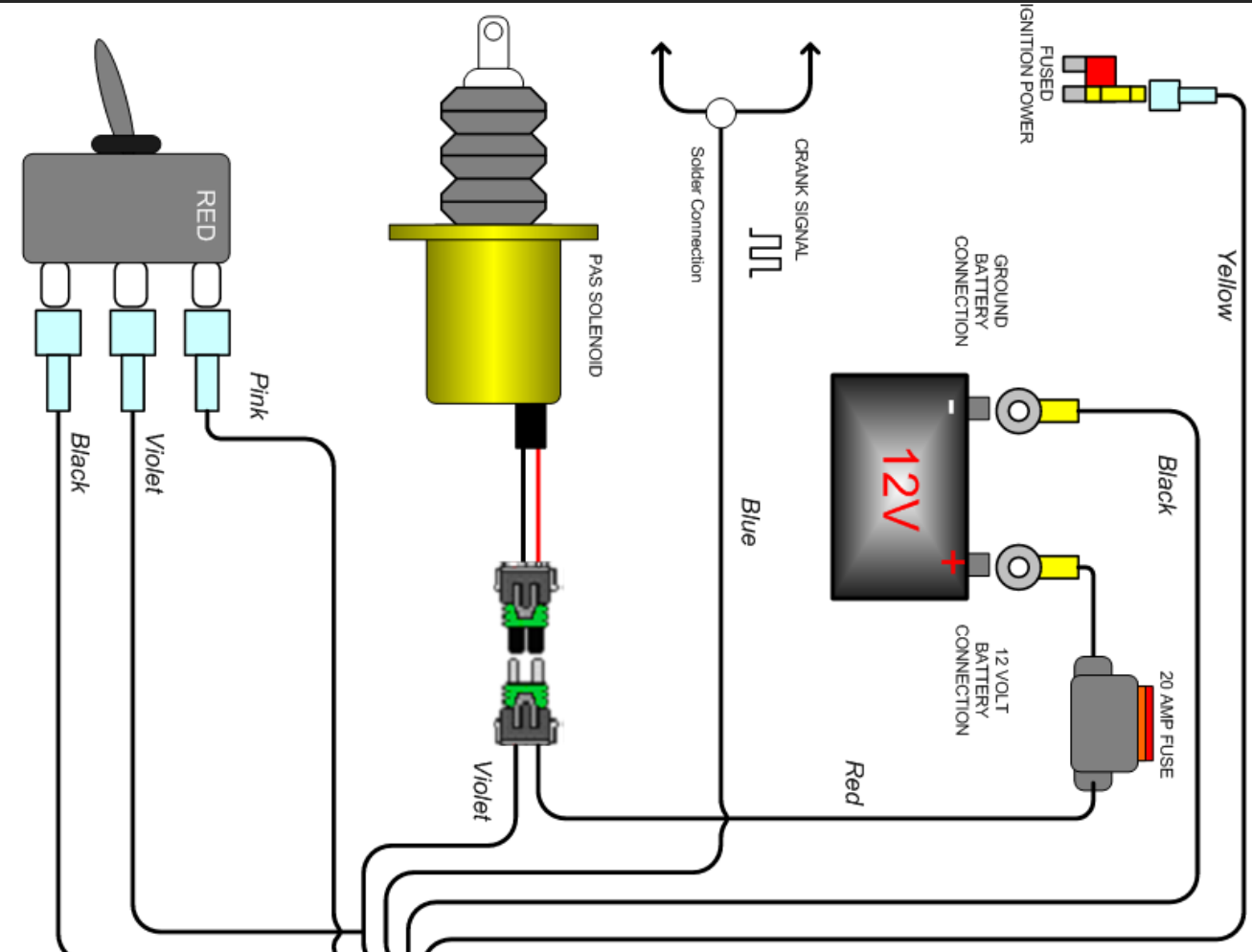

- POSITION 1 = Pre-Programmed Automatic Mode (Vehicle Specific)
- POSITION 2 = Pre-Programmed Test Mode
- POSITION 3 = Full Manual Mode (User must set)

The control unit features a 'Set' button, a gauge, and three indicator lights: Power (red), RPM Set (green), and RPM Signal (blue). Below the unit is a table of application settings:

Application	Cutout RPM	Freq. Hz
Dodge Cummins 2003-09	4200	4200
Dodge Cummins 1998.5-02	4200	2100
Ford 6L Powerstroke	5000	5000
Ford 7.3L Powerstroke	4900	4900
GMI Duramax	4600	4600

WIRING DIAGRAM without OVER SPEED ELECTRONICS (1036719-M)

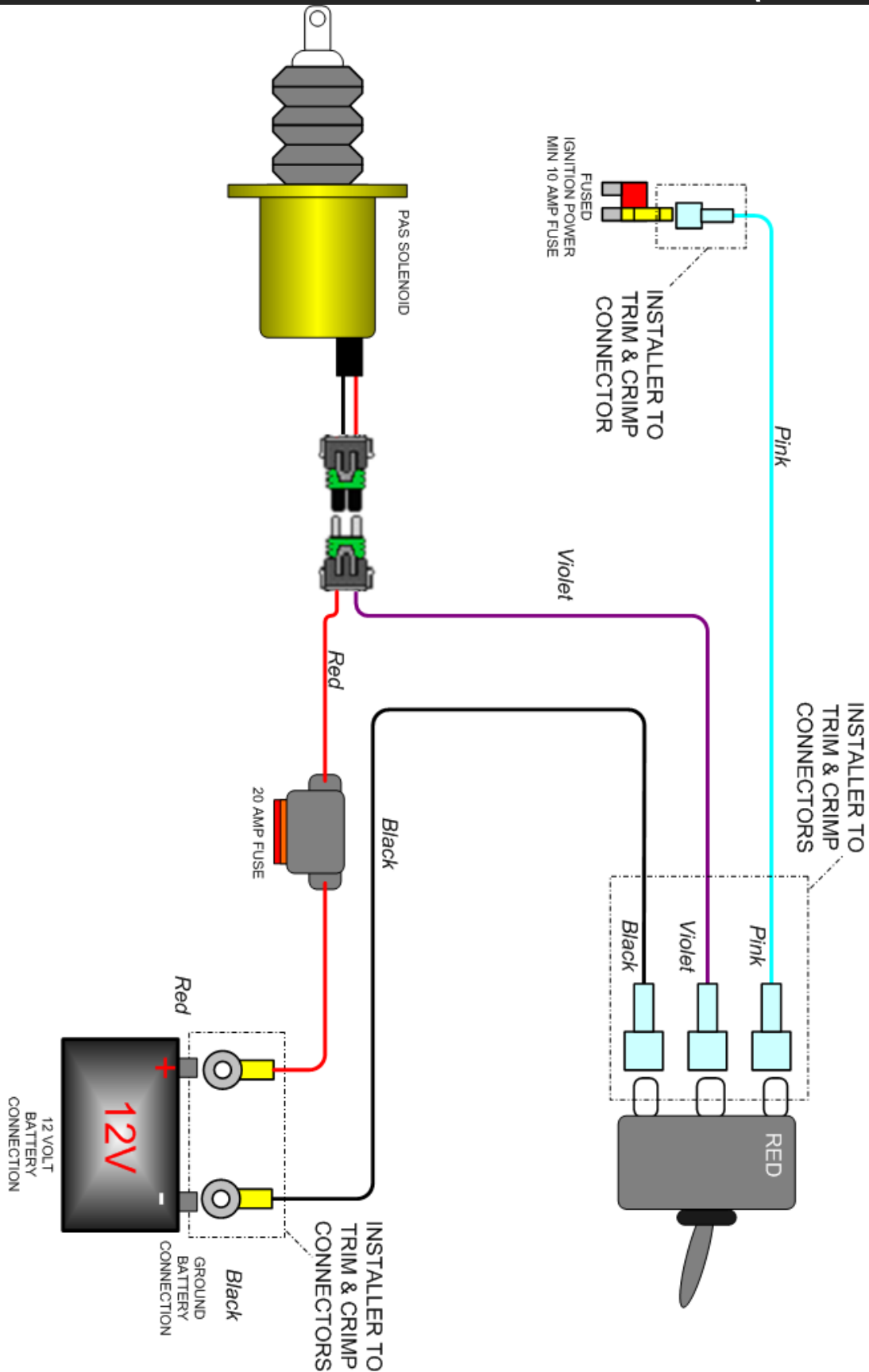

RESETTING THE VALVE

Valve Activated (Closed)

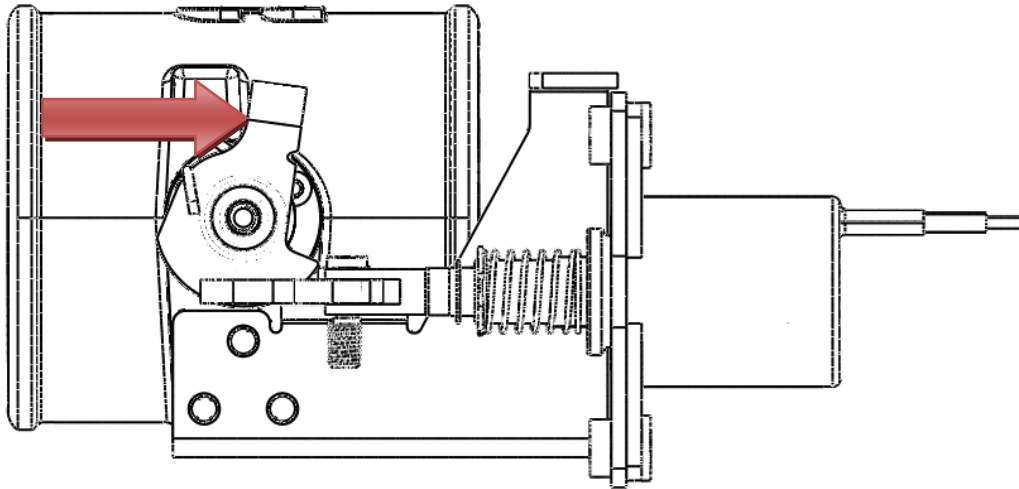

Valve Reset (Open)

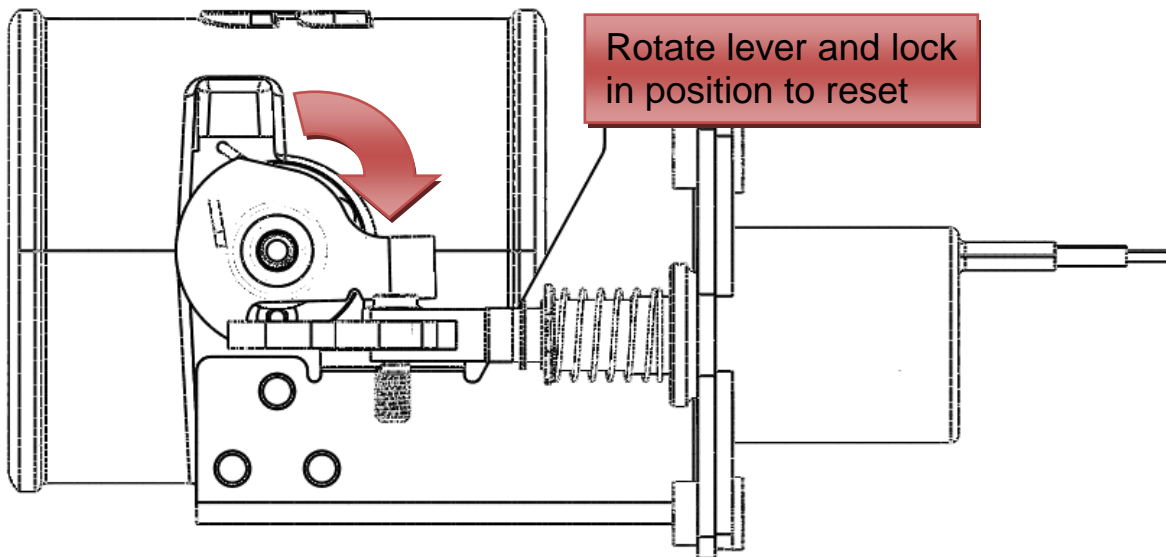

SETUP, TESTING AND VERIFICATION with OVERSPEED ELECTRONICS

Each unit is specifically configured for each model of truck. As in the case of different model years and makes the engine RPM frequency is different.	Engine Idle Speed Frequency
	98.5-02 Dodge Cummins 300-400 Hz (1:2) ratio

2003-2009 Dodge Cummins	Activation RPM	Activation Freq. (Hz)
PAS Switch Position #1 (Automatic Mode)	4200	2100
PAS Switch Position #2 (Test Mode)	1200	600
PAS Switch Position #3 (Manual Mode)	User Configured	User Configured

Automatic Mode (Pre Configured RPM)	
Action	Failure/Fix/Notes
1. Turn the ignition key to the on position. You should see the RED light illuminate on the toggle switch.	If the LED does not illuminate, check the wiring to the back of the switch first. Then check entire circuit.
2. Next, start the engine. 3. With the engine idling, activate the toggle switch. You should hear the solenoid activate and the valve close. The engine should die. Once the engine dies the switch should flicker ON and OFF indicating a trip condition.	If the engine does not die, check to make sure the valve actuated. If the valve did not actuate check switch and ground wiring. If valve did actuate but the engine is still running, ensure nothing has contacted the valve mechanism
4. You can now reset the valve, by rotating the upper lever and engaging the solenoid stop.	

5. With the valve reset, remove the outer enclosure from the control module. There are two locking tabs on the sides of the enclosure.

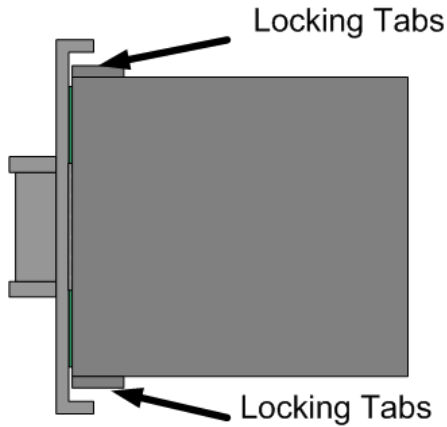

6. Change the position selection switch to position #2 (Auto Test). Slide enclosure cover over circuit board.

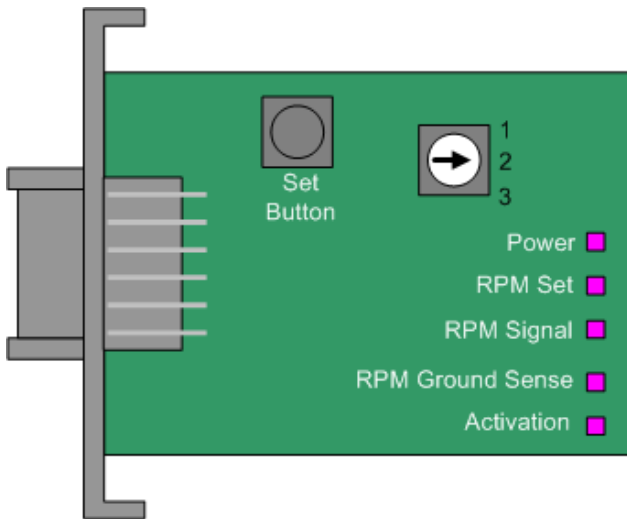

7. Start the vehicle, with the vehicle in park step on the throttle increasing the engine RPM. At 1200RPM the PAS should engage itself automatically, and the engine should stall. Like with all activations the

If the engine did not stall, check to make sure the valve actuated. If the valve did not actuated, double check the engine RPM electrical connection. Check the RPM Signal LED on the circuit

toggle switch should flash.	board, it should flash proportionally to the engine RPM.
<p>8. Reset the valve and reset the mode position switch to position #1</p>	
<p>You are now complete and the unit should function correctly. This test cycle should be completed once a year.</p>	

Manual Mode (User Configured RPM)

Setup

With the control unit, the user/installer has the ability to set their own activation RPM. It is necessary that you chose a low activation RPM first to test the units is operating correctly. Once it has, you will need to set the high limit RPM activation.

Note: When you press the Set button the module will add 25% to the set speed.

1. Open electronic enclosure, by releasing the two locking tabs on the side of the unit.

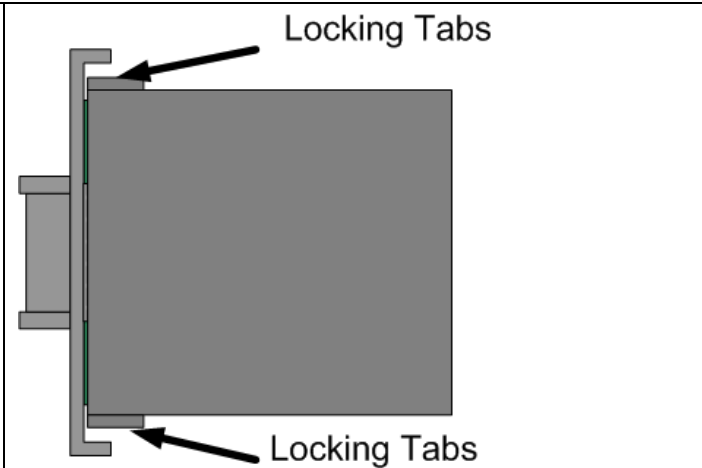

2. Adjust the position switch to Position #3.

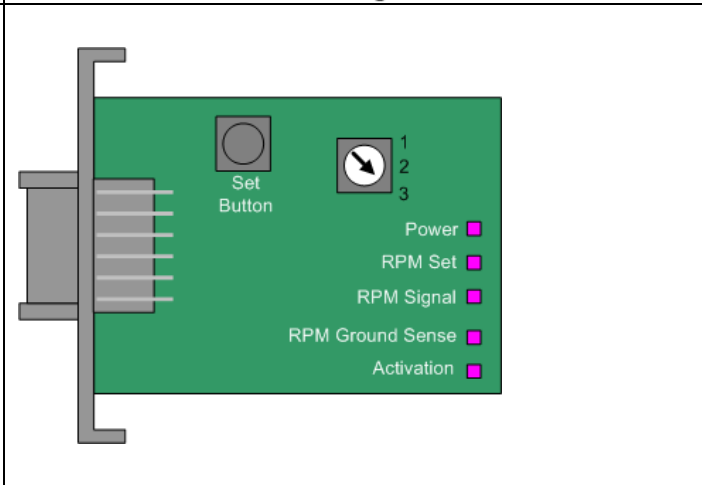
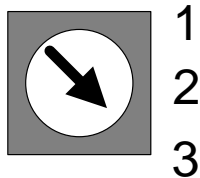

3. Start the engine.

4. Press and hold the RPM SET button.

When you push the SET RPM button will see the "RPM Set" LED illuminate.

5. With another person helping you, have them step on the accelerator with the vehicle in park. Raise the engine RPM to 1200 RPM.

6. Release the SET RPM button.

Upon releasing the button the unit will store the RPM + 25%. So for this example the unit has stored 1200RPM + 25% = 1500RPM.

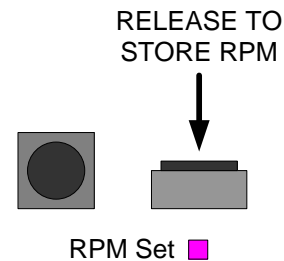
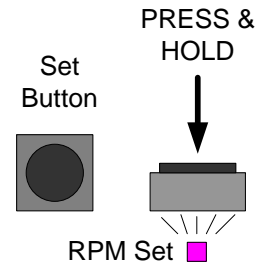

You should see the RPM signal flash proportionally to engine RPM.

7. Now increase the RPM of the engine to test the activation circuit is working correctly. As in this example the valve should activate at 1500RPM.

You should see the ACTIVATION LED flash ON/OFF on activation.

If the valve does not activate check the wiring.

If the valve activates but the engine does not stall, ensure nothing has contacted the valve linkage.

8. With the valve activated the engine should die. Reset the valve and restart the engine.

9. Press and hold the RPM SET button.

When you push the SET RPM button will see the "RPM Set" LED illuminate.

10. With another person helping you, have

BD Engine Brake Inc.

Plant Address: 33541 MacLure Rd. Abbotsford, BC, Canada V2S 7W2

U.S. Shipping Address: 88-446 Harrison St, Sumas, WA 98295 U.S. Mailing Address: P.O. Box 231, Sumas, WA 98295

Phone: 604-853-6096 | Fax: 604-853-8749 | Internet: www.bd-power.com

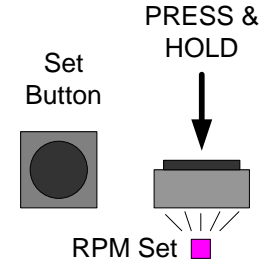
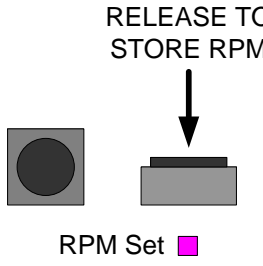
<p>them step on the accelerator with the vehicle in park. Raise the engine RPM to MAXIMUM engine RPM.</p> <p>11. Release the SET RPM button.</p> <p>Upon releasing the button the unit will store the RPM + 25%. So for this example the unit has stored MAXIMUM engine RPM + 25%.</p>	 
<p>12. You can now put the electronic enclosure back together and secure it to the fuse box.</p>	
<p>13. With the engine running you will need to test to make sure the manual activation switch is functioning correctly.</p> <p>14. With the engine running, lift the activation switch and the engine should die.</p> <p>15. Reset the valve and you are now complete.</p>	<p>If valve does not activate check the wiring.</p> <p>If the valve activates and the engine does not die ensure nothing has contacted the linkage.</p>
<p>You are now complete the installation, please be sure to complete the test once a year to make sure the unit is functioning correctly.</p>	

TESTING FLOW CHART with OVER SPEED ELECTRONICS

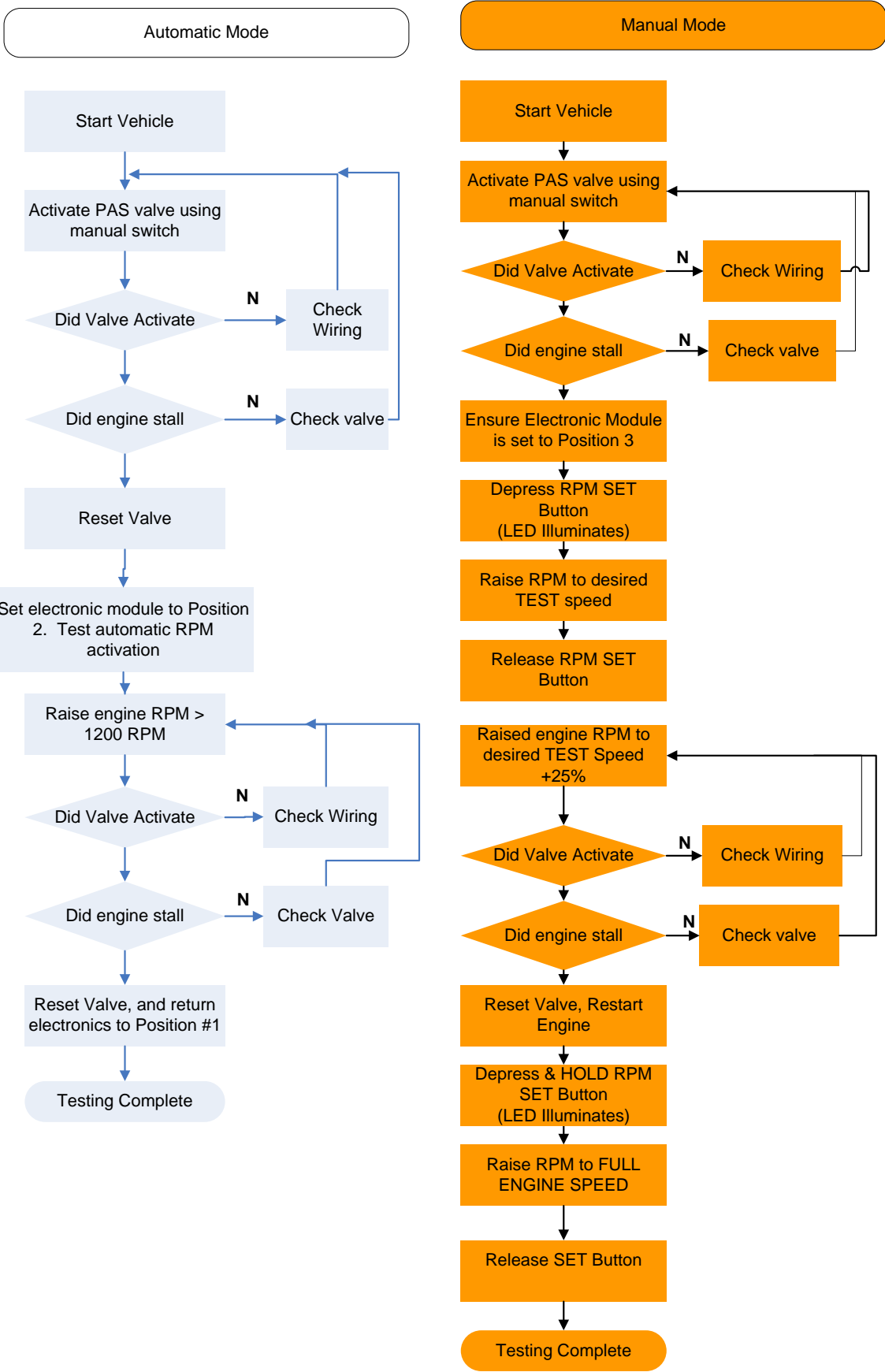

BD Engine Brake Inc.

Plant Address: 33541 MacLure Rd. Abbotsford, BC, Canada V2S 7W2

U.S. Shipping Address: 88-446 Harrison St, Sumas, WA 98295 U.S. Mailing Address: P.O. Box 231, Sumas, WA 98295

Phone: 604-853-6096 | Fax: 604-853-8749 | Internet: www.bd-power.com

TESTING FLOW CHART *without OVER SPEED ELECTRONICS*

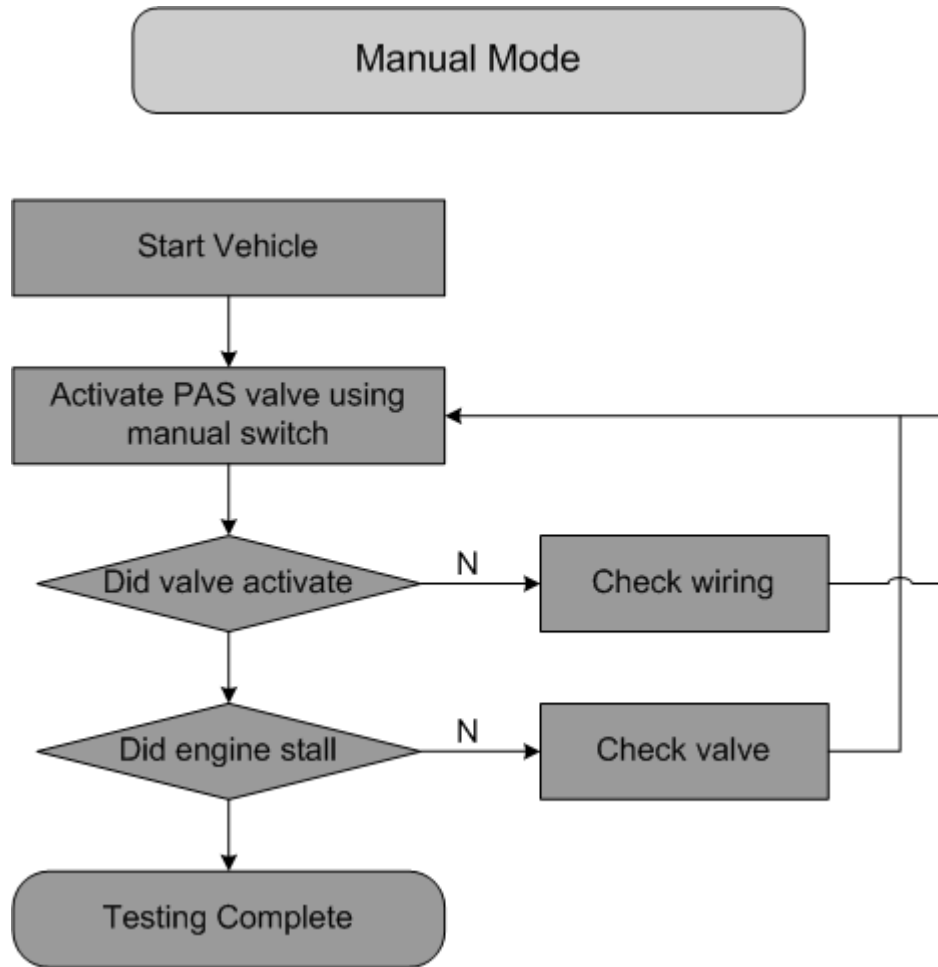

LED OPERATION

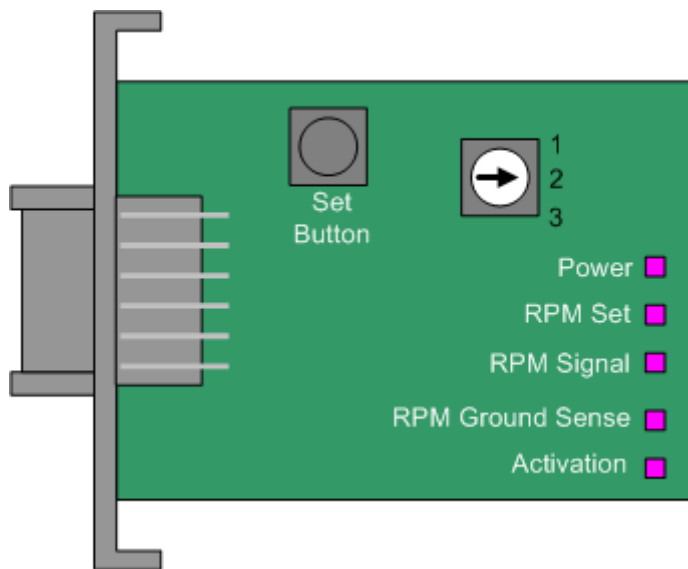

LED	Description
POWER	Illuminates when unit is POWERED
RPM SET	Illuminates when SET Button is Pressed
RPM Signal	Flashes proportional to Engine RPM
Ground Sense	Illuminates when a GROUND signal is sensed on the activation line
Activation	Flashes when a valve activation is command manually (switch) or automatically
Toggle Switch LED	The LED will flash indicating either a problem with the system (Loss of RPM or Power) or an activate valve activation.



Visit our Internet forums at <http://www.dieselperformance.com> and share your comments or technical support questions with some of the industry's leading experts in the diesel field.

If you have any technical difficulties, concerns, comments, or complaints, please phone our Technical Support hotline at (800) 887-5030 between 8:30am-5:00pm PST (Pacific Standard Time) Monday to Friday, or post a message on the BD Discussion Forums located at:

<http://forum.bd-power.com/>