

Ford Ranger / Bronco II

Set Part # 21008

Rev B 5-04



Step 1: Prior to Installation:

- A) **Fit:** Verify the fit of the flares to vehicle. (Some filing, sanding, or cutting may be necessary to ensure proper fit).
- B) **Painting:** (Optional) if paint is desired it must be done prior to installing flares on the vehicle clean outer surface with a good grade degreaser. **DO NOT USE LACQUER THINNER OR ENAMEL REDUCER AS A DEGREASER.** Wipe outer surface thoroughly with a tack rag prior to paint.
Paint flares using a high quality enamel, or polyurethane automotive paint. (Application of a primer coat is optional)
If painting edge trim (not recommended), use a flex additive.
- C) **Performance:** Using larger Tires may increase the area required to turn the vehicle. Some Tire/Rim combinations may require lowering bump stops and or installing steering stops to prevent tire from contacting flare.
- D) **Exhaust System:** Modifications may be necessary to maintain a minimum 4" clearance between flares and exhaust pipes. (Exhaust gases should not vent directly onto flares)
- E) **Metal Protection:** All exposed fasteners and bare metal should be treated with red oxide primer BEFORE installing flares.

TOOLS FOR EASY INSTALLATION

- 3/8" Drill
- 3/16" Drill Bit
- 5/16" Drill Bit
- Pop Rivet Gun
- Sheet metal Cutting Tool (Hacksaw, Sabersaw, Air Chisel, Metal Nibbler, or Air Saw)
- Crescent Wrench
- Grease Pencil or Marking Pen
- Jack and Jack Stands (2)
- Right and Left Hand Aviation Tin Snips
- C-Clamps (2) or Vise Grips (2)
- Tube of Silicone

FLARE INSTALLATION PROCEDURES

Step 2: Disassembly (Front)

- A) Jack up vehicle and use jack stand.
- B) Remove wheel and wheel well trim (if so equipped).
- C) Remove body side moldings on fender only (if so equipped).
- D) From inside of engine compartment, remove wire clips, coil, or vacuum canister from wheel well liner.
- E) Remove screws that attach wheel well liner to fender lip, inner sheet metal, and front sheet metal flange.
- F) Remove entire wheel well liner.

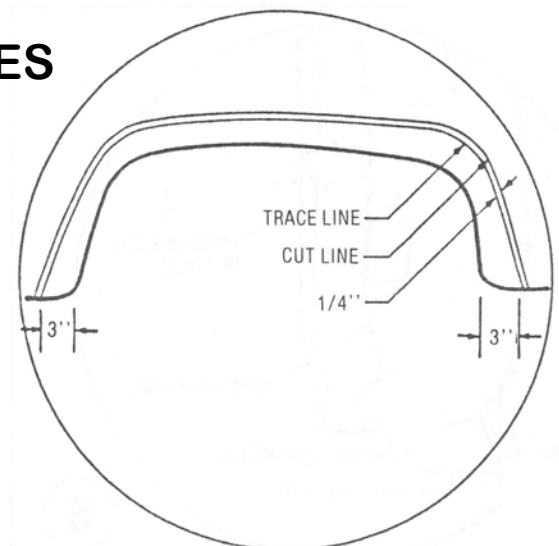

Illustration #1

Step 3: Cutting Sheet Metal (Front)
(See Illustrations #1 - 4)

- A) Mark a line 3" out from existing wheel well opening (both ends). **Illustration #1**
- B) Place appropriate flare on fender, and line up with marks. Make sure bottom returns on flare are against sheet metal at front and rear. Using inner edge of flare as a guide, mark a line all the way around.
- C) Remove flare and mark a line 1/4" above line drawn in Step 3B. This will be the cut line.
- D) Cut along line drawn in Step 3C and remove sheet metal but don't discard.
- E) Draw a line 1-1/8" up from the original opening on sheet metal cut off in Step 3D. Cut on line drawn all the way around. **See Illustration #2.**
- F) On flange trimmed in Step 3E, mark a line at center of opening. From center mark, measure back 7" and 2", mark. From center mark, measure forward 6-3/4" and 5-1/2", mark. Cut at five marked lines on outside face only. Cut off radius at each end of flange (back approximately 3/4"). Bend flange at cut marks to fit contour of fender cut out.
- G) Mark a line 1" up and around fender cut out. Place flange behind fender cut out and up 1/8". Center flange mark to center of fender cut out. Drill and pop rivet (use steel rivet with backup washer) slightly to front side center. Continue riveting sequence to one side of center. Adjust bend in flange to maintain 1/8" up. Repeat operation for other side of center. There will be four rivets to the front of center and four rivets to the rear of center, for a total of nine rivets including center rivet. **See Illustrations #3 and #4.**

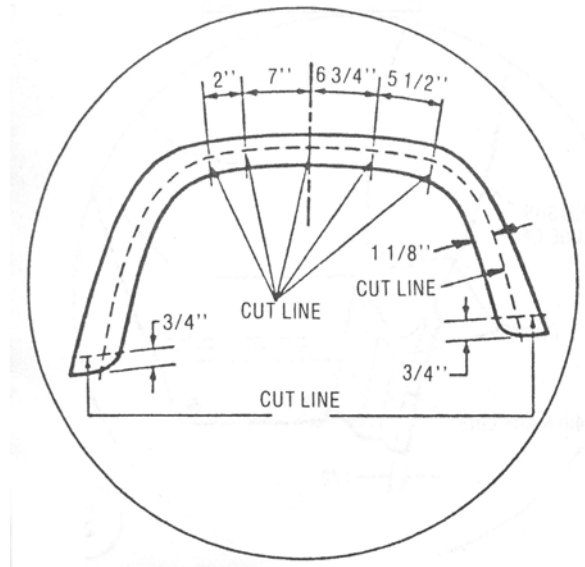

Illustration #2

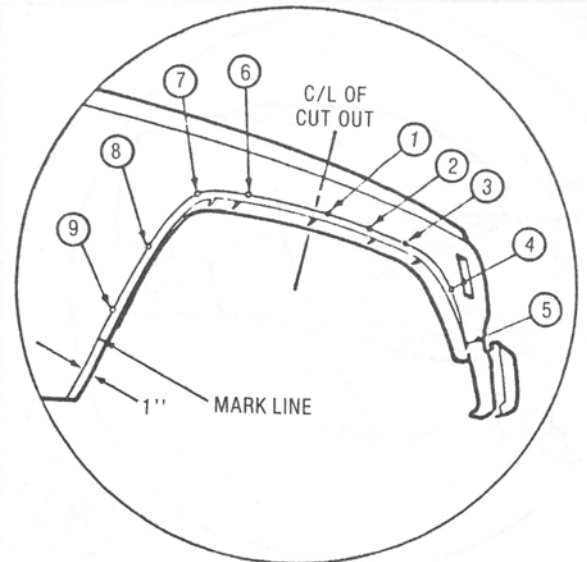

Illustration #3

Step 4: Trimming and Attaching Wheel Well Liner
(See Illustrations #5 - 12 and #19)

- A) Mark the first line 2-1/4" back from front edge of front mounting flat. This line will continue down the side. **See Illustration #5.** Mark the second line starting at and in line with the rear flat of the wheel well liner. **See Illustration #6.** As this line progresses up the radius, maintain 4" in from edge and continue around to a point 5-1/2" up from the bottom at front. At this point radius out 90° to the edge of liner (will be in line where front mounting flat contacts wheel well radius). **See Illustration #7.** The third mark is 5-1/2" up from front mounting flat and continues around to a point 2-1/2" up from front mounting flat. **See Illustration #8.** The fourth and final mark will be at lower outside front. Mark a line starting at and in line with outside edge of liner. This line will continue to the front edge of liner. **See Illustration #9.** Cut

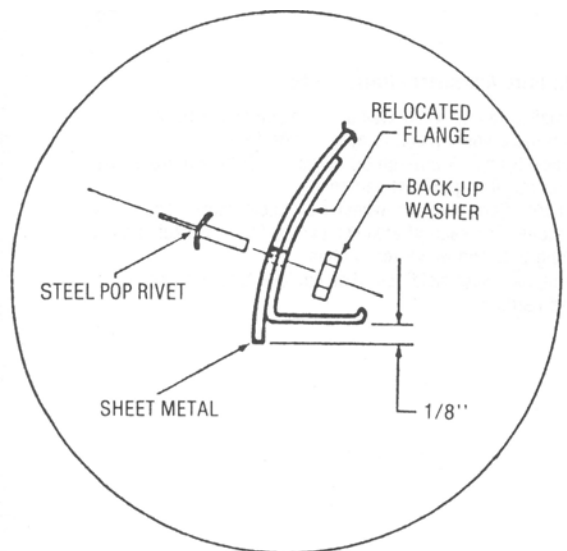

Illustration #4

wheel well liner in same sequence as marks were laid out.

- B)** Clamp filler strip (provided) to lower rear outside of wheel well liner. Use outside rib in flat as the stop. There should be 1/2" approximate overlap. Working towards the front, filler strip should locate next to first screw boss on wheel well liner. Clamp to wheel well liner if you have long C-clamp vise grips. Continue to work forward, filler strip will not locate next to second screw boss. **See Illustration #10.** As the filler strip runs off the end of wheel well liner, there should be approximately 1" overlap at this point. Clamp filler strip at this end. Using steel rivets and back-up washers, start drilling and pop riveting a total of six rivets equally spaced from rear to front. Rivet from underside and use back-up washer on top side. Reinstall wheel well liner into wheel well opening and attach, using two original screws at top. Attach filler strip to flange radius (front and rear), using sheet metal screws supplied. Filler strip should protrude beyond wheel well opening. Measure up 3-1/2" from lower front sheet metal and mark a horizontal line onto filler strip. Mark a trace line (starting at 3-1/2" line) where the fender sheet metal intersects the protruding filler strip. **See Illustration #11.** Remove all fasteners and wheel well liner. From trace line draw another line 1/8" inward; this will be the cut line. Start at 3-1/2" line, cut from inside out to outer cut line and stop. Cut from rear around to 3-1/2" cut point. Retain excess trimmed material, this will be used later. Reinstall wheel well liner into fender opening. Attach with two original screws at top and two sheet metal screws at both radii. Check fit at sheet metal to be sure filler strip is behind and flush with it. Position front portion of wheel well liner (cut off in Step 4A) over flange at lower front of wheel well opening. Note: The clip nuts will be attached to the wheel well liner, instead of sheet metal flange. Also, wheel well liner will be on top of the flange instead of underneath. Holding front liner, move fender side portion against sheet metal. Drill one pop rivet hole at upper corner where liner overlaps the filler strip. Place a rivet into drilled hole as a locator (do not cinch together). Drill another pop rivet hole at lower outside corner where liner overlaps the filler strip. Place another pop rivet into drilled hole as a locator (do not cinch together). Using existing two holes in front sheet metal flange, mark location onto liner from underside. Remove front liner portion and complete wheel well liner. Drill through front liner portion where marked with a 5/16" drill. Place front liner portion over filler strip and align two pop rivet holes. Pop rivet together using back-up washers on opposite side. Reinstall into fender opening and attach two sheet metal screws in radius. From trimmed filler strip scrap, cut a piece 3" wide x 14" long. **See Illustration #12.** This will bridge the gap between the two wheel well liner

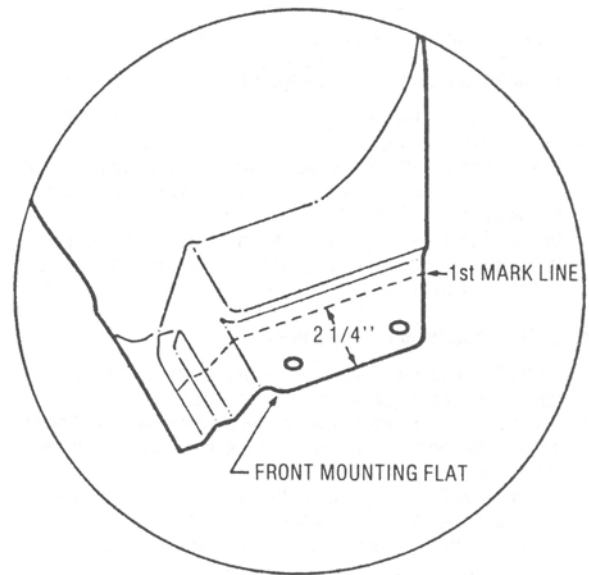

Illustration #5

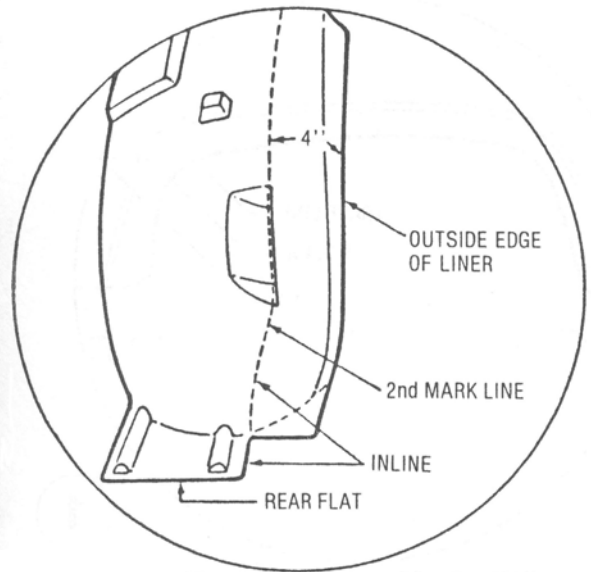

Illustration #6

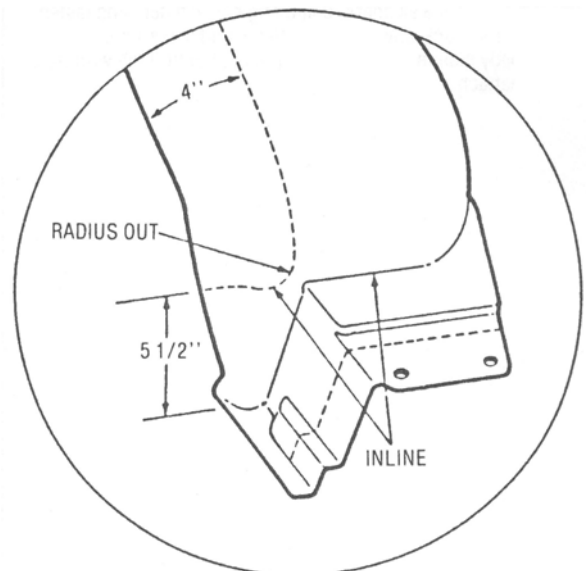

Illustration #7

pieces. Place the end of the strip at inside edge of two liner parts. Center strip over gap and hold in place. Drill one pop rivet hole on each side of strip and through liner. Pop rivet together using back-up washers on opposite side. Remove six fasteners holding wheel well liner in place and remove entire wheel well liner. At center of strip, 3/8" in from each side, drill and pop rivet together using back-up washers on opposite side. Trim outer edge of strip in line with liner pieces. At outside edge of strip, back 3/8" and on center, drill and pop rivet through strip and filler strip. Use back-up washer on opposite side. The wheel well liner assembly is now (finally) ready for final attachment. Install into wheel well opening and loosely attach two top screws and two front flange screws. Make sure outer filler strip is tucked behind sheet metal. Beginning at center of wheel well opening, push filler strip against flange and drill pop rivet together. Alternate back and forth from center until filler strip is completely fastened. Use holes in radii that were used for sheet metal screws as pop rivet locations. Use a total of eleven pop rivets equally spaced for this attachment. Secure two top screws and two front flange screws.

- C) Cut a rectangular strap (1-1/2" wide by 6" long) from filler strip scrap. Drill and pop rivet (steel pop rivet) one end of strap to rear flat of wheel well liner. Pull wheel well liner rearward. Drill through strap and body mount flange. Secure with a steel pop rivet. **See Illustration #19.** This operation will provide tire to wheel well liner clearance when steering is in full lock position. Note: on driver side, it will be necessary to cut a slot in wheel well liner for emergency brake cable.

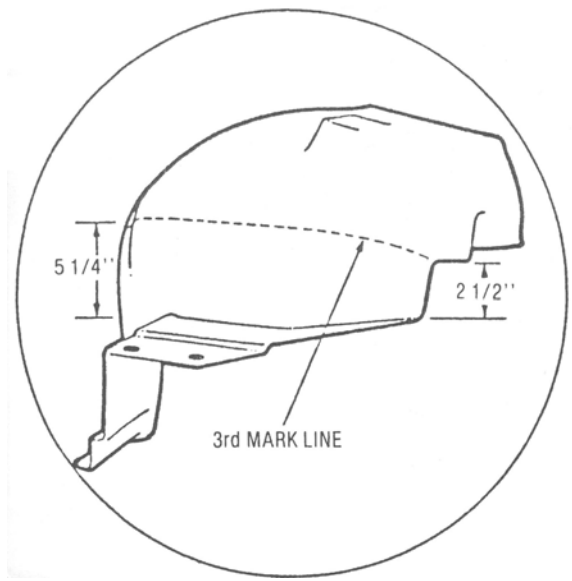

Illustration #8

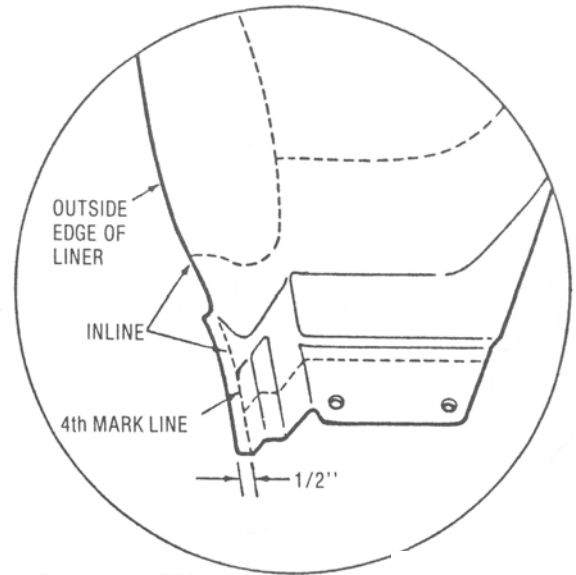

Illustration #9

Step 5: Flare Attachment (Front)
(See Illustrations #13 - 16)

- A) With flare off the truck: Pre-drill all of the pop rivet locating indents with either a 5/32" or 3/16" drill bit. Be careful to avoid damaging the flare with drill motor chuck when drilling. A tape wrapped depth stop on drill bit will serve as a safety stop. **See Illustration #13.**
- B) Fit flare tightly into fender well opening, making sure flare contour matches sheet metal contour. Use pre-drilled holes in flare to serve as drill guides to drill 9/64" holes in fender sheet metal. Again the wrapped tape depth stop will prevent damage to flare by drill chuck when drilling through sheet metal.
- C) With everything ready: Pop rivet (use the aluminum rivets) the outer flare, attaching points first, using riveting sequence shown in **Illustration #14.** Don't forget the cup washers under rivet head. Note: Cup washers are applied to outer pop rivet pockets only. Continue riveting sequence while maintaining tight

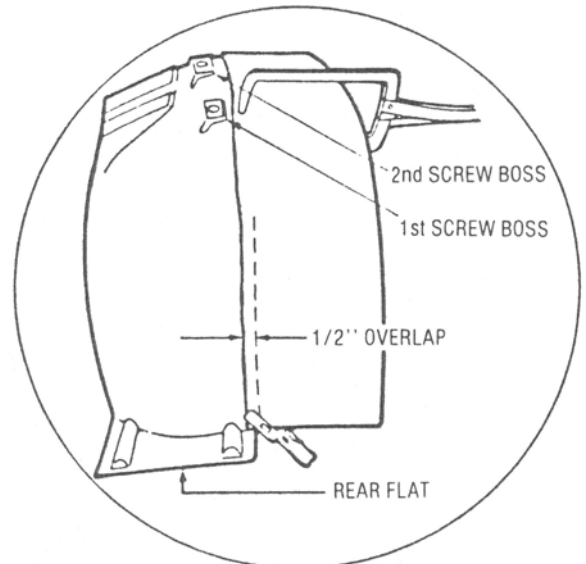

Illustration #10

contact between flare and sheet metal. Finish riveting with two front and two rear underside rivets. On two front rivets, the rivet nearest tire should pass through flare, sheet metal and wheel well liner.

- D) Press trim caps onto outer flare rivet washers. **See Illustration #15.**
- E) Reinstall all wire clips, coil, or vacuum canister on wheel well liner.
- F) Trim body side molding (if so equipped) to fit flush with flare and reattach.
- G) Trim front spoiler in line with inside edge of flare. **See Illustration #16.**

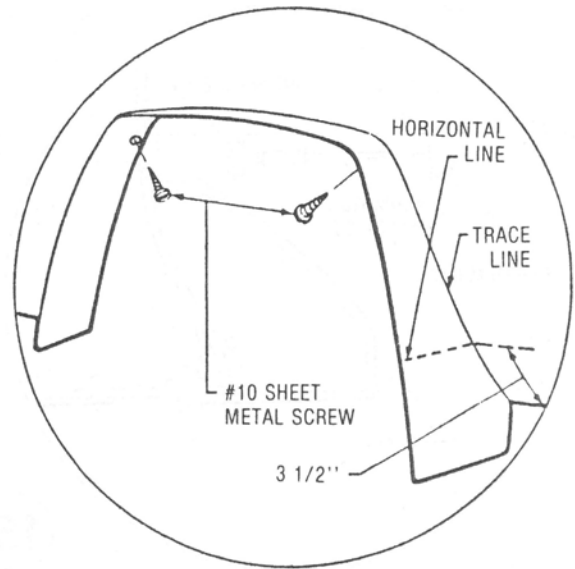

Illustration #11

Step 6: Disassemble (Rear)

- A) Jack up vehicle and remove tire. Don't forget to use a jack stand.
- B) Remove wheel well trim and side moldings (if so equipped).
- C) Remove lower support bracket fasteners at front and rear of opening.
- D) Remove both wheel well liners.

**Step 7: Cutting Sheet Metal (Rear 21008)
(See Illustration #17)**

- A) Mark a line 2-1/4" back (front and rear) at lower legs of wheel well opening. When installing 21008 on 1989 model, mark line is 1-1/2" instead of 2-1/4". Place flare over sheet metal. Align lower inside edges with reference lines on sheet metal. Be sure bottom edges (front and rear) are snug with turn under of sheet metal. Hold in place, using inner edge as a guide, and mark a line on sheet metal all the way around. Remove flare and mark a line 1/4" above line just drawn. This will be the cut line.
- B) Cut out sheet metal all the way around cut line. Bend sheet metal down slightly. This will reveal an inner panel at the top. Cut this panel in line with outer panel. Remove cut-away sheet metal. You will note that the inner panel is no longer attached to the outer sheet metal. To reattach, locate triangular shaped flat area at each end of inner panel. Drill from inside of wheel well out through both panels in these two areas. Use steel pop rivets to secure panels together. **See Illustration #17.**

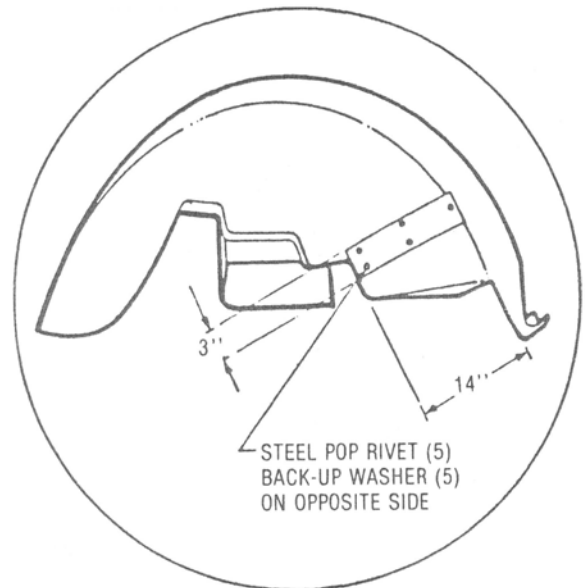

Illustration #12

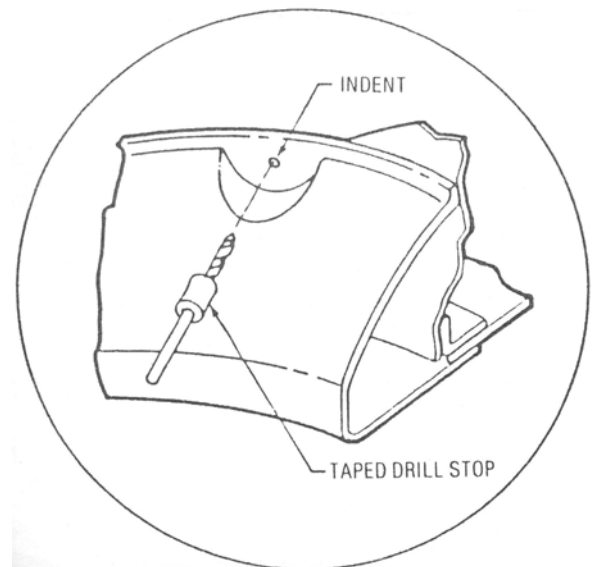
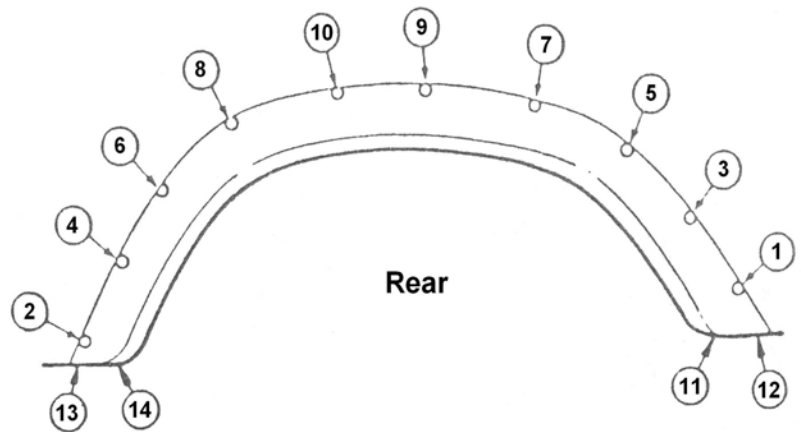
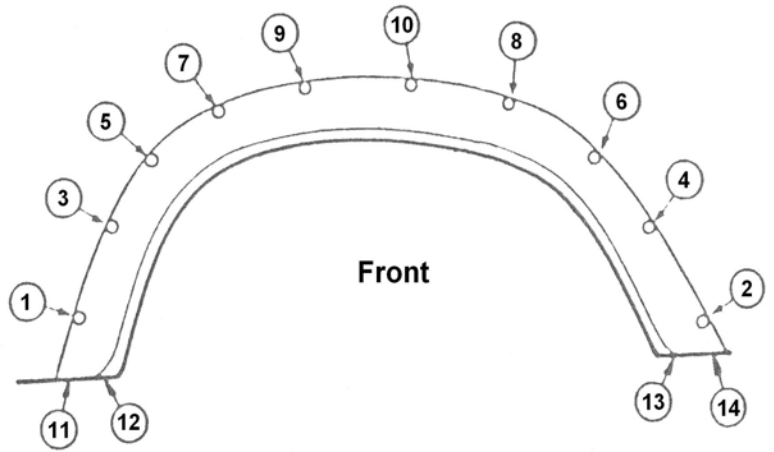

Illustration #13

**Step 8: Cutting Sheet Metal (Rear 21010)
(See Illustration #18)**

- A) Mark a line 2-1/4" back (front and rear) at lower legs of wheel well opening. When installing 21010 on 1989 model, mark line is 1-1/2" instead of 2-1/4". Place flare over sheet metal. Align lower inside edges with reference lines on sheet metal. Be sure bottom edges (front and rear) are snug with turn under of sheet metal. Hold in place, using inner edge as a guide, and mark a line on sheet metal all the way around. Remove flare and mark a line 1/4" above line just drawn. This will be the cut line.
- B) Cut out sheet metal all the way around cut line. Note: Part of cut (front and top area) will be two panel construction. Remove cut away sheet metal.
- C) Using silicone to fill gap between outer and inner panels at front, drill and pop rivet (steel pop rivets and back-up washers) at front. See Illustration #18.



**Step 9: Flare Attachment (Rear 21008)
(See Illustrations #13 - 15)**

- A) Install flare into wheel well opening and check fit. If necessary, trim more sheet metal to accommodate flare.
- B) Hold flare in place. From inside wheel well, mark location of support rod holes onto flare. Remove flare and drill 5/16" holes at marked locations.
- C) With flare off the truck: Pre-drill all of the pop rivet locating indents with either a 5/32" or 3/16" drill bit. Be careful to avoid damaging the flare with drill motor chuck when drilling. A tape wrapped depth stop on drill bit will serve as a safety stop. See Illustration #13.
- D) Fit flare tightly into fender well opening, making sure flare contour matches sheet metal contour. Use pre-drilled holes in flare to serve as drill guides to drill 9/64" holes in fender sheet metal. Again the wrapped tape depth stop will prevent damage to flare by drill chuck when drilling through sheet metal.
- E) With everything ready: Pop rivet (use the aluminum rivets) the outer flare, attaching points first, using riveting sequence shown in Illustration #14. Don't forget the cup washers under rivet head. Note: Cup washers are applied to outer pop rivet pockets only. Continue riveting sequence while maintaining tight contact between flare and sheet metal. Finish riveting with two front and two rear underside rivets.
- F) Press trim caps onto outer flare rivet washers. See Illustration #15.
- G) Swing support brackets into position and reattach, using original fasteners.

Illustration #14

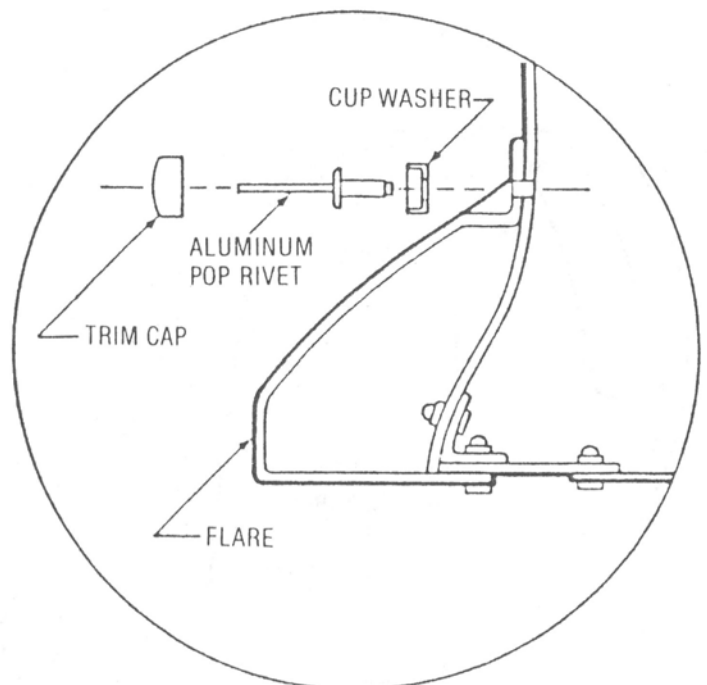

Illustration #15

- H) Reinstall wheel well liners, using original fasteners and fastening points. Tuck any protruding liner under the flare.
- I) Trim Body side moldings (if so equipped) to fit flush with flare and reattach.

Step 10: Flare Attachment (Rear 21010)

- A) Install flare into wheel well opening and check fit. If necessary, trim more sheet metal to accommodate flare.
- B) With flare off the truck: Pre-drill all of the pop rivet locating indents with either a 5/32" or 3/16" drill bit. Be careful to avoid damaging the flare with drill motor chuck when drilling. A tape wrapped depth stop on drill bit will serve as a safety stop. **See Illustration #13.**
- C) Fit flare tightly into fender well opening, making sure flare contour matches sheet metal contour. Use pre-drilled holes in flare to serve as drill guides to drill 9/64" holes in fender sheet metal. Again the wrapped tape depth stop will prevent damage to flare by drill chuck when drilling through sheet metal.
- D) With everything ready: Pop rivet (use the aluminum rivets) the outer flare, attaching points first, using riveting sequence shown in **Illustration #14**. Don't forget the cup washers under rivet head. Note: Cup washers are applied to outer pop rivet pockets only. Continue riveting sequence while maintaining tight contact between flare and sheet metal. Finish riveting with two front and two rear underside rivets.
- E) Press trim caps onto outer flare rivet washers. **See Illustration #15.**
- F) Where flare overlaps wheel well sheet metal, seal off with silicone. The seal-off area will extend from the radius at front, along top, and down rear radius.
- G) Trim Body side moldings (if so equipped) to fit flush with flare and reattach.

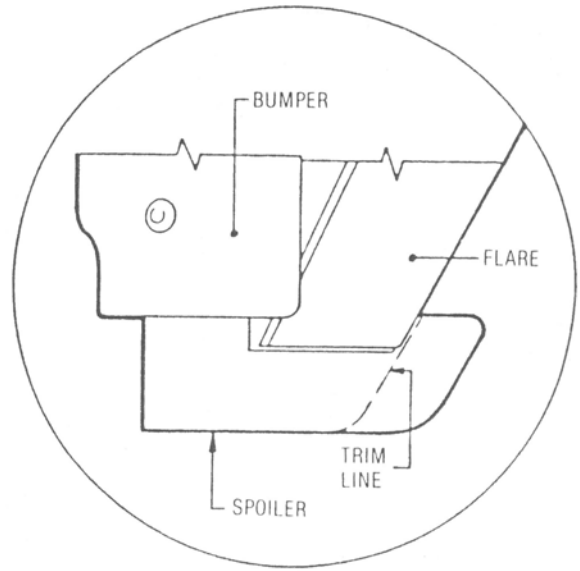

Illustration #16

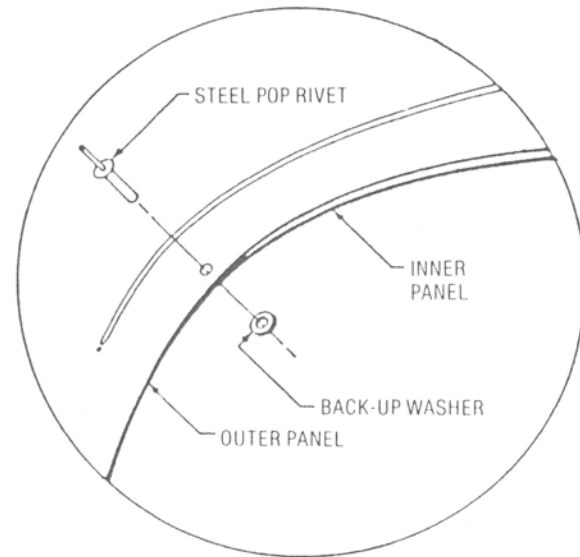

Illustration #17

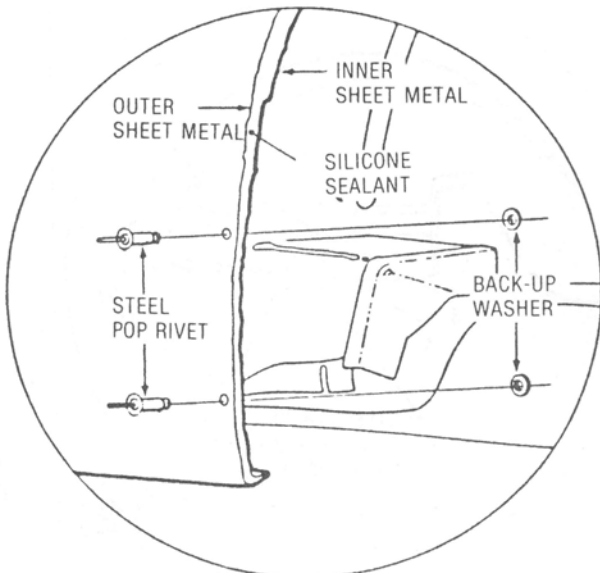

Illustration #18

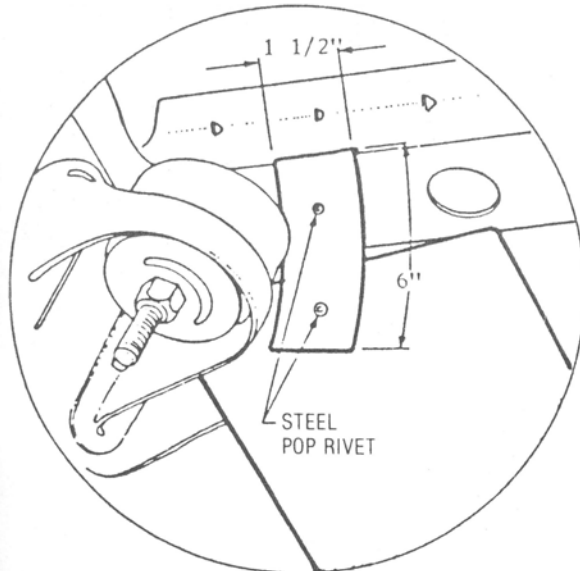

Illustration #19



INSTALLATION INSTRUCTIONS FOR **CUT-OUT FLARE GIMP**

Tools Required for Installation:

A. Nail or Awl

STEP 1: APPLICATION:

Follow flare installation instructions to the point of drilling first hole through sheet metal with the supplied bit. Sandwich gimp between flare and sheet metal; pierce a hole through gimp using pre-drilled hole in flare as a guide. Secure and continue as flare installation instructions direct. NOTE: make sure bulb of gimp is tight against top of flare when securing.

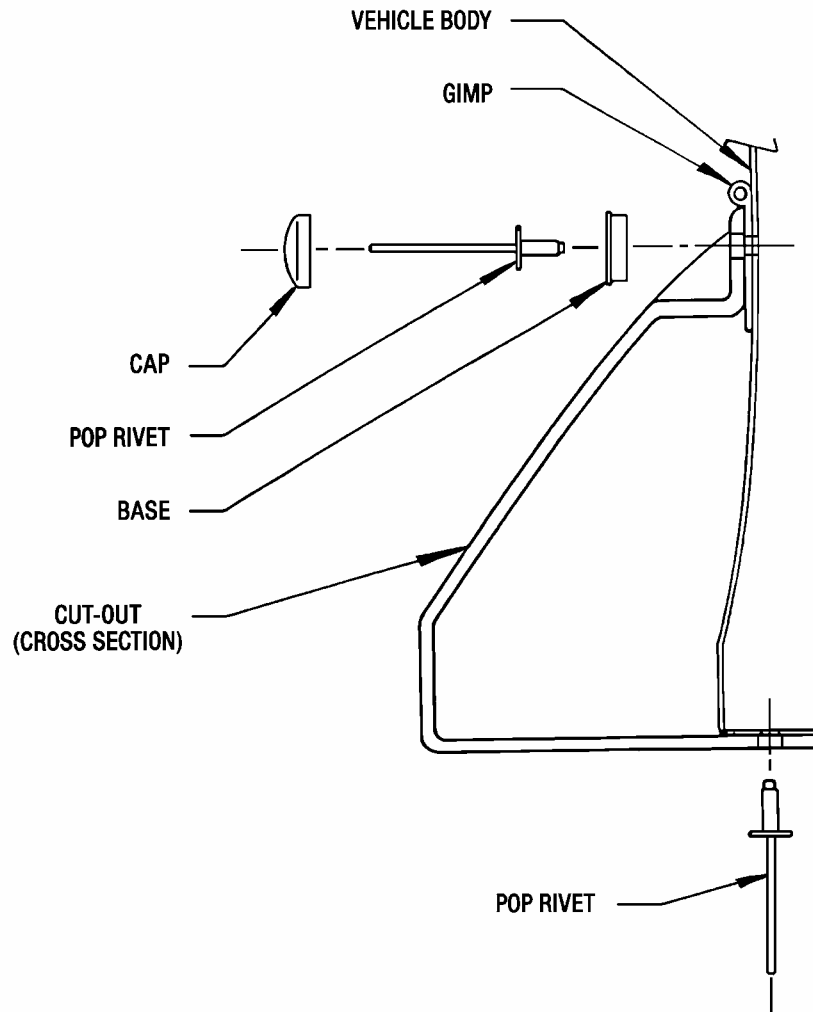



IN1-S001

ATTENTION:

To help benefit the consumer, Bushwacker fender flares are now supplied with drill tip screws in place of aluminum rivets. If you receive the fastener kit including drill tip screws, use the instructions provided with the following exceptions:

Fender flare attachment

1. Hold flare in place on fender.
2. Applying moderate pressure to outside surface of flare, fasten with kit supplied drill tip screws using indents in flare as a guide. Drill through the plastic into the sheet metal. Take care not to strip out the sheet metal.