



INSTALLATION INSTRUCTIONS

MSD Pro-Billet Small Diameter Ford V8 Distributor

PN 8577; 351C-460, PN 8578; 351W
PN 8579; 302

Important: Read these Instructions before attempting the installation.

Contents

Timing Functions
Choosing an Advance Curve
Setting or Locking Out the Centrifugal Advance
Installing the Distributor
Wiring the Distributor

Parts Included:

1 - Pro-Billet Distributor
1 - Rotor, PN 8467
1 - Distributor Cap, PN 8431
1 - Advance Kit
1 - O-ring Seal
1 - Tube of Gear Lubricant
1 - Parts Bag

Note: An MSD Pro-Billet Distributor must be used with an MSD Ignition Control.

Note: The spark plug wire terminals of the Small Diameter Distributors are HEI style terminals. You may need to change the terminals and boots of your wires. MSD offers a kit, PN 8879, that comes with nine boots and terminals.

TIMING FUNCTIONS

Before continuing with the installation, here are a few definitions you should be aware of:

Initial Timing: This is the base timing (also referred to as idle timing) of the engine before the centrifugal advance begins.

Centrifugal Advance: The centrifugal (or mechanical) advance mechanism is made up of weights, springs, advance cam, and an advance stop bushing. The amount and rate of advance that your distributor is capable of is determined by the centrifugal timing. If you ever wish to lock out the centrifugal advance, refer to the centrifugal advance section.

Total Timing: This is the total of the initial timing plus the centrifugal advance added together. Example: 10° Initial + 25° centrifugal = 35° Total Timing.

CHOOSING AN ADVANCE CURVE

The function of the advance curve is to match the ignition timing to the burning rate of the fuel and speed (rpm) of the engine. Any factor that changes the burning rate of the fuel or the engine speed can cause a need for an ignition timing change. Figure 1 shows some of the factors that will affect engine timing.

FACTOR	Advance Timing For	Retard Timing For
Cylinder Pressure	Low	High
RPM	Low	High
Vacuum	High	Low
Energy of Ignition	Low	High
Fuel Octane	High	Low
Mixture (Air/Fuel)	Rich	Lean
Temperature	Cool	Hot
Combustion Chamber Shape	Open	Compact
Spark Plug Location	Offset	Center
Combustion Turbulence	Low	High
Load	Light	Heavy

Figure 1 Ignition Timing Factors.

As you can see from the chart, most factors will change throughout the range of the engine operation. The timing mechanism of the distributor must make timing changes based on these factors.

Example: A Ford V8 has 11:1 compression, a high energy ignition and turns 5,500 rpm. With the specifications given, you will have to retard the timing for the high compression, low rpm and high energy ignition. By comparing the engine's specifications against the chart, a usable timing guideline can be found. Engines with a combination of items from both columns will require a timing that is set in the mid range.

Obviously a full technical explanation of correct ignition timing would be very complicated. The best way to arrive at a suitable ignition curve for your engine is to use the Ignition Timing Factors Chart as a guide and compare it to the Advance Graphs in Figure 2 until a suitable curve is found. When selecting your advance curve, use detonation (engine ping) as an indicator of too much advance, and a decrease in power as an indicator of too little advance.

TIPS ON SELECTING AN ADVANCE CURVE

- Use as much initial advance as possible without encountering excessive starter load or engine kick-back.
- Start the centrifugal advance just above the idle rpm.
- The starting point of the centrifugal advance curve is controlled by the installed length and tension of the spring.
- How quickly the centrifugal advance (slope) comes in is controlled by the spring stiffness. The stiffer the spring, the slower the advance curve.
- The amount of advance is controlled by the advance bushing. The bigger the bushing, the smaller the amount of advance.

CENTRIFUGAL ADVANCE CURVE

The centrifugal advance mechanism is made up of weights, springs, an advance cam and the advance stop bushing. The distributor can be used in a wide selection of applications by changing only the springs and the advance stop bushing. There is no need to change the weights or advance cam.

SELECTING THE ADVANCE SPRINGS

The rate, or how quick the advance comes in is determined by the type of springs which are installed on the distributor. The MSD distributors are equipped with two Heavy Silver springs installed. These will give you the slowest advance curve possible. The parts kit contains two additional sets of springs which can be used to match the advance curve to your particular application. Refer to the Spring Combination Chart (Figure 2) for combinations that can be achieved.

SPRING COMBINATION	RATE OF ADVANCE	FIGURE 3 (Page 4)
2- Heavy Silver	SLOWEST	A
1- Heavy Silver		B
1- Light Blue		
1-Heavy Silver		C
1-Light Silver		
2- Light Blue		D
1- Light Silver		E
1- Light Blue		
2- Light Silver	FASTEST	F

Figure 2 Spring Combination Chart.

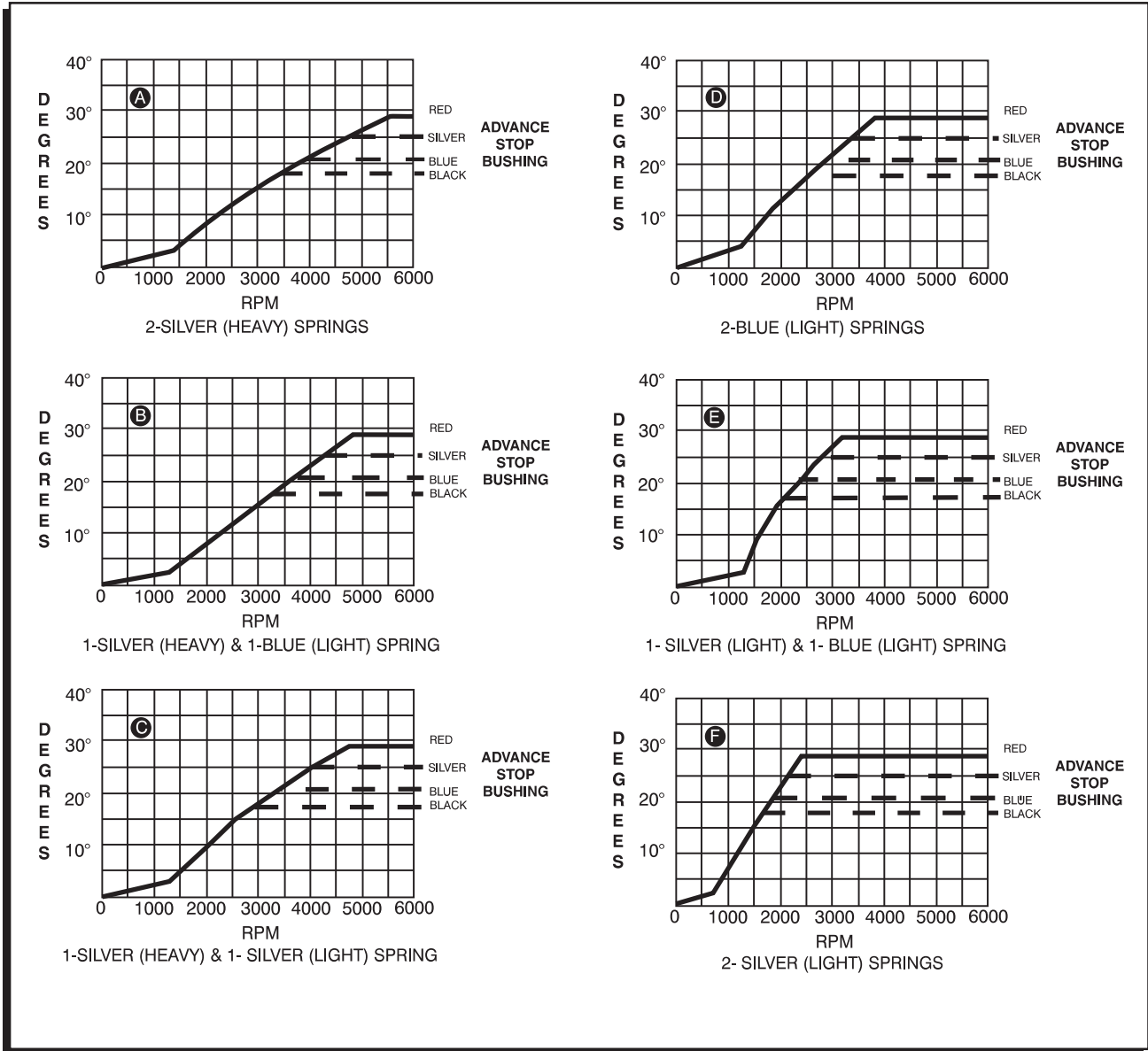

Figure 3 Advance Curves.

INSTALLING THE ADVANCE SPRINGS

1. Remove the distributor cap and rotor.
2. Using long needle nose pliers, remove the springs from the spring posts.
3. Install the new springs using the pliers and install the rotor and cap.

SELECTING THE ADVANCE STOP BUSHING

Three different advance stop bushings are supplied in the distributor kit. The distributor comes with a Blue (21°) bushing already installed. If a different amount of centrifugal advance is desired, follow the next procedure to change the bushings. The chart in Figure 4 gives the size and approximate degrees for the corresponding bushings.

BUSHING SIZE	APPROXIMATE CRANKSHAFT DEGREES
Red-Smallest	28
Silver	25
Blue	21
Black-Largest	18

Figure 4 Advance Stop Bushing Chart.

CHANGING THE ADVANCE STOP BUSHINGS

1. Remove the distributor cap and rotor.
2. Remove the locknut and washer on the bottom of the advance assembly (Figure 5).
3. Remove the bushing and install the new one. Install the washer and locknut.

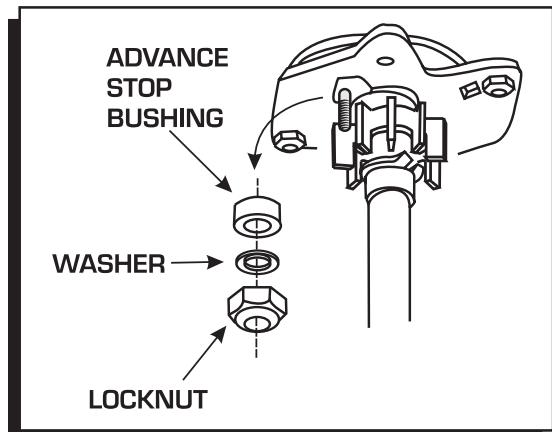

Figure 5 Changing the Advance Stop Bushing.

LOCKING OUT THE CENTRIFUGAL ADVANCE

1. Remove the cap and rotor.
2. Remove the advance springs, weights and the advance stop bushing from the advance assembly.
3. Remove the roll-pin from the shaft and slide the retaining sleeve down. It should not be necessary to remove the gear (Figure 6).
4. Slide the shaft two inches out of the housing.
5. Rotate the shaft 180° and insert the advance stop bushing pin into the small hole on the advance plate (Figure 7).

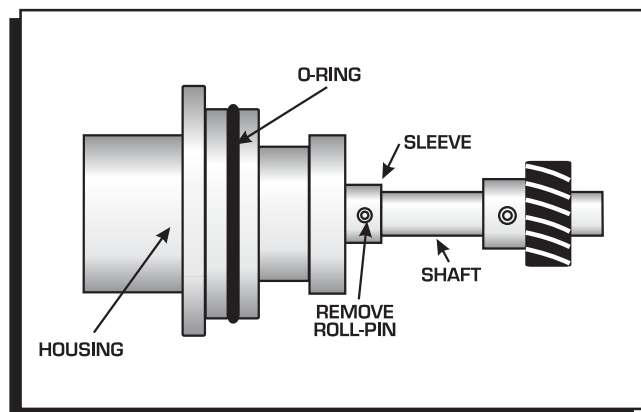

Figure 6 Removing the Retaining Sleeve.

6. Install the locknut and washer to the advance stop bushing pin.
7. Install the retaining sleeve and roll-pin.

INSTALLING THE DISTRIBUTOR

1. Remove the existing distributor cap without disconnecting any of the spark plug wires.
2. With the cap off, crank the engine until the rotor is aimed at a fixed point on the engine or firewall. Note this position by making a mark (Figure 8).
3. Place the distributor cap back on and note which plug wire the rotor is pointing to. **MARK THE SPARK PLUG WIRES** and remove the distributor cap.
4. Disconnect the wiring from the distributor.
5. Loosen the distributor hold-down clamp and slide the clamp out of the way and lift the distributor out of the engine.
6. Install the supplied O-ring seal in the groove on the distributor land. Apply a thin layer of oil to the housing O-ring.
7. Install the distributor making sure that the rotor comes to rest pointing at the fixed mark. If the distributor will not fully seat with the rotor pointing to the marked position, you may need to rotate the oil pump shaft until the rotor lines up and the distributor fully seats.
8. Position and tighten the hold-down clamp onto the distributor.
9. Install the rotor and distributor cap. It is recommended to use a drop of Blue Loctite to the distributor cap hold down bolts.
10. Install the spark plug wires from the old cap one at a time to ensure correct location.

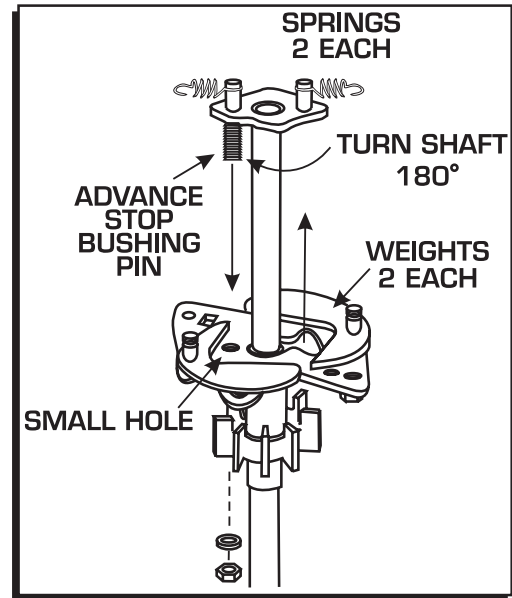

Figure 7 Locking Out the Centrifugal Advance.

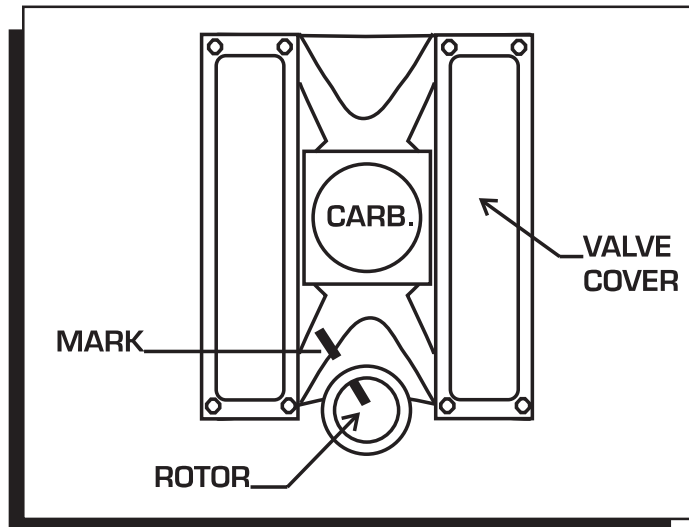

Figure 8 Marking the Rotor Location.

WIRING THE DISTRIBUTOR

The MSD Pro-Billet Distributor must be used with an MSD Ignition Control. Figure 9 shows the wiring for the MSD distributor with an MSD 6 and 7 Series Ignition Control. After wiring the distributor, check the timing.

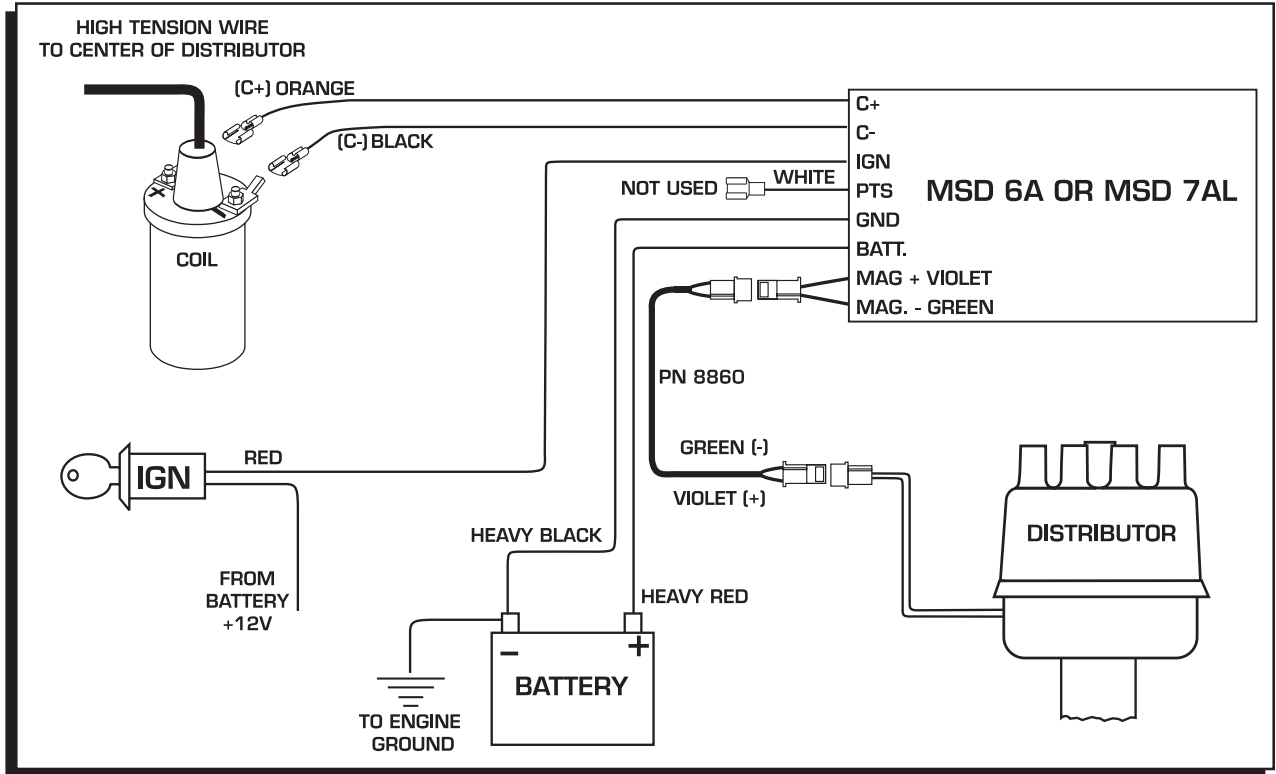

Figure 9 Wiring the Distributor.

TECH NOTES
