



# INSTALLATION INSTRUCTIONS

## MSD Super HEI Kit PN 8400, with MSD 6A Ignition Control PN 8500, with MSD 6AL Ignition Control

### Parts Included:

- |                              |   |
|------------------------------|---|
| 1 - MSD 6 Series Ignition    | 1 - Modified HEI Dust Cover, PN 8401          |
| 1 - Harness, PN 8860         | 1 - Pink Wire (not used)                      |
| 1 - Parts Bag                | 1 - Brown Wire (not used)                     |
| 1 - MSD 6 Series Ignition    | 1 - Coil Bracket                              |
| 1 - Harness, PN 8860         | 1 - Diode Terminal, for 5-Pin HEI Module only |
| 1 - Parts Bag                |   |
| 1 - Blaster 2 Coil, PN 8202  |   |
| 2 - Brass Nuts & Lockwashers |   |
| 1 - Heli-Core Wire, PN 8403  |   |
| 1 - Power Tower              |   |

### 6AL Only:

- 4 - RPM Modules, 3,000, 6,000, 7,000, 8,000
- 4 - Vibration Mounts and Hardware

**WARNING:** During installation, disconnect the battery cables. When disconnecting the battery always remove the Negative cable first and install it last.

**WARNING:** Very high voltages are present at the coil when the engine is running. Never connect any test equipment or touch the coil while the engine is cranking or running.

**Note:** Solid Core spark plug wires **cannot** be used with an MSD Ignition.

**Note:** An MSD 6 Series **cannot** be used with distributorless ignition systems (DIS).

## THEORY OF 6 SERIES IGNITION

### CAPACITIVE DISCHARGE

The MSD 6 Series Ignitions feature a capacitive discharge ignition design. The majority of stock ignition systems are inductive ignitions. In an inductive ignition, the coil must store and step up the voltage to maximum strength in between each firing. At higher rpm, since there is less time to charge the coil to full capacity, the voltage falls short of reaching maximum energy which results in a loss of power or top end miss.

The MSD Ignition features a capacitor which is quickly charged (within one millisecond) with 460 - 480 volts and stores it until the ignition is triggered. With the CD design, the voltage sent to the coil is always at full power, even at high rpm.

### MULTIPLE SPARKS

The MSD 6 Series produces full power multiple sparks for each firing of a plug. The number of multiple sparks that occur decreases as rpm increases, however the spark series always lasts for 20° of crankshaft rotation. Above 3,000 rpm there is simply not enough "time" to fire the spark plug more than once, so there is only one powerful spark.

### REV LIMITER

6AL Only: This ignition is equipped with built-in Adjustable Soft Touch Rev Controls. MSD Rev Limiters are adjustable with plug-in modules which are available in 100 rpm increments. The Soft Touch circuitry provides a smooth and accurate rev limit by dropping the spark to individual cylinders. The Soft Touch produces a load-free rev limit that is within 1% of the selected rpm.

## GENERAL INFORMATION

### BATTERY

An MSD 6 Series Ignition Control will operate on any negative ground, 12 volt electrical system with a distributor. The MSD can be used with 16 volt batteries and can withstand a momentary 24 volts in case of jump starts. The Ignitions will deliver full voltage with a supply of 9 - 18 volts and will operate with a supply voltage as low as five volts.

If your application does not use an alternator, allow at least 15 amp/hour for every half hour of operation. If the engine is cranked with the same battery or other accessories such as an electric fuel or water pump are used, the amp/hour rating should be higher.

### COILS

The MSD 6 Series Ignitions can be used with most stock coils and aftermarket coils designed to replace the stock coils. There are some "race only" coils such as the MSD Pro Power Coil, PN 8201, that **cannot** be used with a 6 Series MSD Ignition Control. For more information on recommended coils, consult the supplied Coil Application Chart or check with the manufacturer of your coil. If you have any questions concerning coils, contact our Customer Service Department at (915) 855-7123.

### TACHOMETERS

The MSD Ignition features a Tach Output Terminal on the side of the unit. This terminal provides a trigger signal for tachometers, a shift light or other add-on rpm activated devices. The Tach Output Terminal produces a 12 volt square wave signal with a 20% duty cycle.

Some vehicles with factory tachometers may require a Tach Adapter to operate with the MSD. For more information on Tachometers and MSD Tach Adapters, see the Tachometer Section on page 9.

If your GM vehicle has an inline filter it may cause the tach to drop to zero on acceleration. If this occurs, bypass the filter

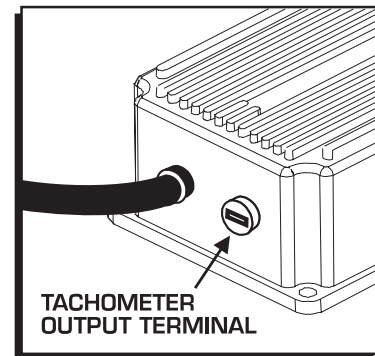

Figure 1 Tach Terminal

### SPARK PLUGS AND WIRES

Spark plug wires are very important to the operation of your ignition system. A good quality, helically wound wire and proper routing are required to get the best performance from your ignition, such as the MSD Heli-Core or 8.5mm Super Conductor Wire.

**Note:** Solid Core spark plug wires cannot be used with an MSD Ignition.

A helically, or spiral wound wire must be used. This style wire provides a good path for the spark to follow while keeping Electro Magnetic Interference (EMI) to a minimum. Excessive EMI, such as the amount that solid core wires produce, will interfere with the operation of the MSD.

**Routing:** Correct routing of the plug wires is also important to performance. Wires should be routed away from sharp edges and engine heat sources. If there are two wires that are next to each other in the engine's firing order, the wires should be routed away from each other to avoid inducing a spark into the other wire. For example, in a Chevy V8, the firing order is 1-8-4-3-6-5-7-2. The #5 and #7 cylinders are next to each other in the engine and in the firing order. If the voltage from the #5 wire is induced into #7 detonation could occur and cause engine damage. To add more heat protection to your plug wires, MSD offers Pro-Heat Guard, PN 3411. This is a glass woven and silicone coated protective sleeve that you slide over your plug wires. For extra protection of the spark plug boots, MSD offers Pro-Heat Boot Guard, PN 3412.

**Spark Plugs:** Choosing the correct spark plug design and heat range is important when trying to get the best performance possible. Since there are so many engine combinations and manufacturers, MSD does not recommend which plug or gap is exactly right for your application. It is recommended to follow the engine builder or manufacturer's specification for spark plugs. With that, you can then experiment with the plug gap to obtain the best performance. The gap of the plugs can be opened in 0.005" increments, then tested until the best performance is obtained. MSD judges the plug gap by compression and components:

These examples are just starting points to get you going in the right direction. Every application is different and should be tested and tuned.

Compression	Spark Plug Gap
Up to 10.5:1:	0.050" - 0.060"
10.5:1 - 13.0:1:	0.040" - 0.050"
Above 13.0:1:	0.035" - 0.045"

**MISCELLANEOUS INFORMATION**

**Sealing:** Do not attempt to seal the MSD. All of the circuits of an MSD receive a thick conformal coating of Humi-Seal. This sealant protects the electronics from moisture. If you were to seal the unit, any moisture or water that may seep in through the wiring grommets will not be able to drain and may result in corrosion.

**Welding:** If you are welding on your vehicle, to avoid the chance of damage, always disconnect both Heavy Power cables of the MSD. (You should also disconnect the tach ground wire too).

**Distributor Cap and Rotor:** It is recommended to install a new distributor cap and rotor when installing the MSD Ignition Control. The cap should be clean inside and out especially the terminals and rotor tip. Also, inspect the Rotor Bushing. MSD offers a new HEI Cap, PN 8411, which is supplied with a new Rotor Bushing. A rotor is available as PN 8410.

**Initial Spark:** It is normal, yet not very common, for the MSD to produce a spark when the ignition key is turned On. This is due to the capacitor being charged and if the pickup is in the right position, it could trigger the ignition momentarily. This could also occur when installing the positive battery cable.

**CYLINDER SELECT**

**Note:** The 6A does not require any modifications to run on 4 or 6-cylinder even-fire engines.

The Soft Touch Rev Limiter that is built into the MSD 6AL is programmed for operation on an 8-cylinder engine. If you are installing one of these units on a 4 or 6-cylinder even-fire engine, the ignition must be modified. This is easily achieved through the cylinder select device on the side of the ignition. To program the unit:

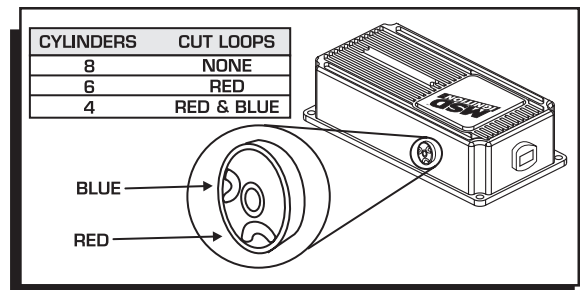

**Figure 2 Selecting the number of Cylinders.**

1. Locate and remove the round black cover with a single Phillips screw.
2. There are two wire loops, a Red and Blue loop. Refer to the chart in Figure 2 to determine which loop to cut for your application.
3. After cutting the loop(s), turn the wire ends away from each other so they cannot come into contact. Install the cover and screw.

## MOUNTING

The MSD Ignition can be mounted in most positions, except directly upside down (if upside down, moisture or water cannot escape). It can be mounted in the engine compartment as long as it is away from direct engine heat sources. It is not recommended to mount the unit in an enclosed area such as the glovebox.

When you find a suitable location to mount the unit, make sure the wires of the ignition reach their connections. Hold the Ignition in place and mark the location of the mounting holes.

- If you have a 6A Ignition, use an 1/8" drill bit to drill the holes. Use the supplied self tapping screws to mount the box.
- If you have a 6AL use a 3/16" drill bit and drill the holes for the supplied vibration mounts. Install the vibration mounts, then mount the Ignition.

## COIL AND BRACKET

It is recommended to mount the coil so it is in an upright position to achieve proper cooling of the windings. Find a suitable location that is away from direct engine heat sources and make sure the MSD wiring and the Coil Wire reach their connections.

## MODIFIED DUST COVER

1. The cap needs to be removed to connect the MSD so disconnect the wiring connectors from the distributor cap and lift it off the distributor.
2. Remove the screws holding the dust cover in position and lift the cover off.
3. Remove the four screws retaining the coil and remove the coil and its wiring.
4. Inspect the rotor bushing for wear and replace if necessary. Make sure the rubber bushing remains in place and install the Modified Dust Cover using the original hardware. Note that the brass terminal must make contact with the rotor bushing (Figure 3).

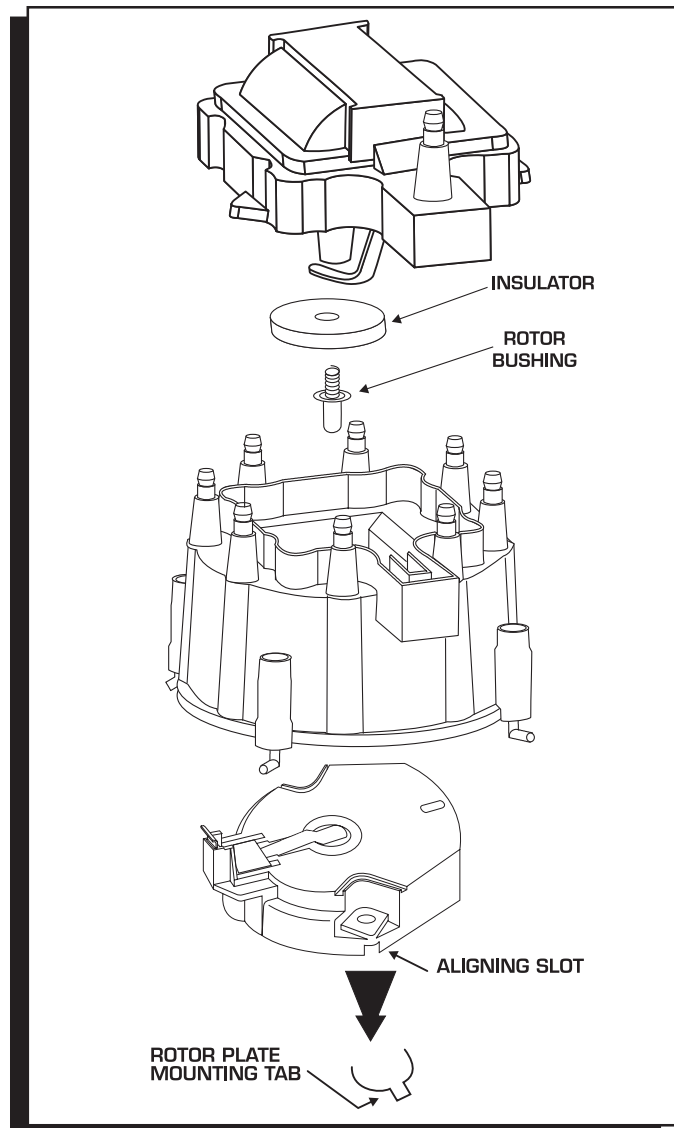

Figure 3 Installing the Modified Dust Cover.

## IDENTIFYING THE HEI MODULE

GM used three different ignition modules throughout the years that HEI distributor was used. Before you begin wiring the MSD system, you need to identify which module your distributor is equipped with. This is easy to do by counting the number of terminals on both ends of the module (Figure 4). Once you know which module is in the distributor, refer to the corresponding wiring diagram to complete the wiring.

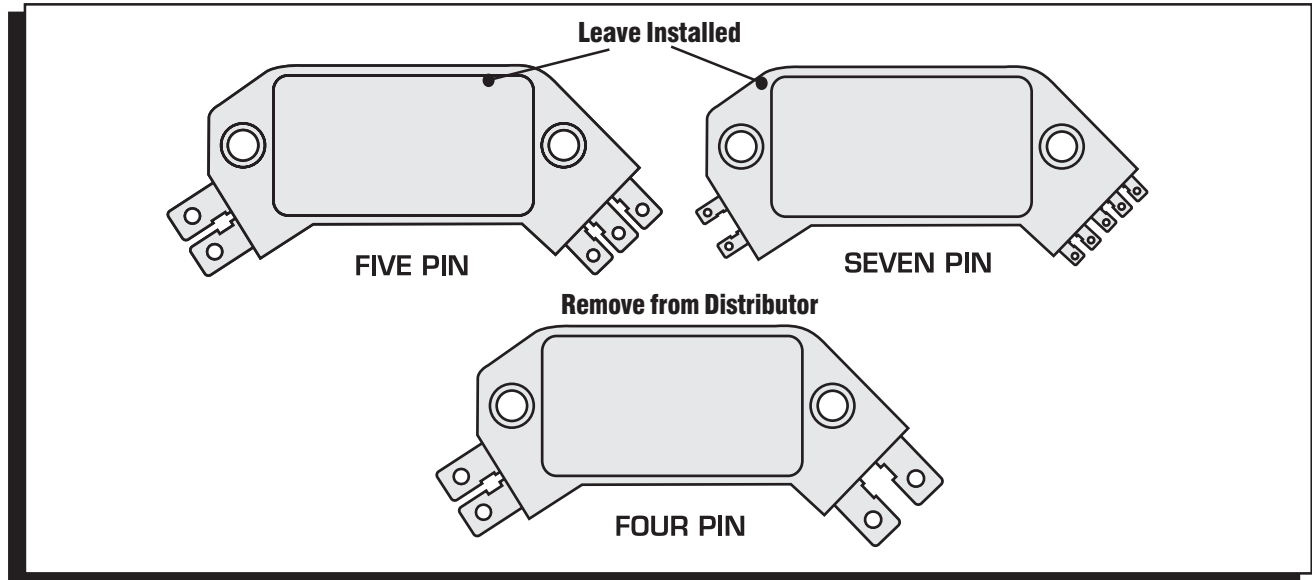

Figure 4 Identifying the HEI Module.

## WIRING

### GENERAL WIRING INFORMATION

**Wire Length:** All of the wires of the MSD Ignition may be shortened as long as quality connectors are used or soldered in place. To lengthen the wires, use one size bigger gauge wire (10 gauge for the power leads and 16 gauge for the other wires) with the proper connections. All connections must be soldered and sealed.

### ROUTING WIRES

The MSD wires should be routed away from direct heat sources such as exhaust manifolds and headers and any sharp edges. The trigger wires should be routed separate from the other wires and spark plug wires. It is best if they are routed along a ground plane such as the block or firewall which creates an electrical shield. The magnetic pickup wires should always be routed separately and should be twisted together to help reduce extraneous interference.

**Grounds:** A poor ground connection can cause many frustrating problems. When a wire is specified to go to ground, it should be connected to the battery negative terminal, engine block or chassis. There should always be a ground strap between the engine and the chassis. Always securely connect the ground wire to a clean, paint free metal surface.

**WARNING:** The MSD 6 Series Ignitions are capacitive discharge ignitions. High voltage is present at the coil primary terminals. Do not touch the coil or connect test equipment to the terminals.

## WIRE FUNCTIONS

<b>Power Leads</b>	These are the two heavy gauge wires (12 gauge) and are responsible for getting direct battery voltage to the Ignition. The ignition has an internal fuse so no fuse is necessary.
<b>Heavy Red</b>	This wire connects directly to the battery positive (+) terminal or to a positive battery junction or the positive side of the starter solenoid. <b>Note:</b> Never connect to the alternator.
<b>Heavy Black</b>	This wire connects to a good ground, either at the battery negative (-) terminal or to the engine.
<b>Red</b>	Connects to a switched 12 volt source. Such as the ignition key or switch.
<b>Orange</b>	Connects to the positive (+) terminal of the coil. <b>This is the only wire that makes electrical contact with the coil positive terminal.</b>
<b>Black</b>	Connects to the negative (-) terminal of the coil. <b>This is the only wire that makes electrical contact with the coil negative terminal.</b>
<b>Trigger Wires</b>	There are two circuits that can be used to trigger the MSD Ignition; a Points/ Amplifier circuit (White wire) and a Magnetic Pickup circuit (Violet and Green wires). The two circuits will <b>never</b> be used together.
<b>White</b>	This wire is used to connect to the points, electronic ignition amplifier output or to the Yellow wire of an MSD Timing Accessory. <b>When this wire is used, the Magnetic Pickup connector is not used.</b>
<b>Violet and Green (Magnetic Pickup Connector)</b>	These wires are routed together in one harness to form the Magnetic Pickup connector. The connector plugs directly into an MSD Distributor or Crank Trigger. It will also connect to factory magnetic pickups or other aftermarket pickups. The Violet wire is positive (+) and the Green is negative (-). <b>When these wires are used, the White wire is not.</b>

**PRESTART CHECK LIST**

- The only wires connected to the coil terminals are the MSD Orange to coil positive and Black to coil negative.
- The small Red wire of the MSD is connected to a switched 12 volt source.
- If running a 6AL on a 4 or 6-cylinder engine the cylinder select must be modified.
- The MSD power leads are connected directly to the battery positive and negative terminals.
- The battery is connected and fully charged if not using an alternator.
- The engine is equipped with at least one ground strap to the chassis.

**THEFT DETERRENT**

The MSD provides the opportunity to easily install a theft deterrent kill switch (Figure 5).

**White Wire Trigger**

When using the WHITE wire to trigger the MSD, install a switch across the magnetic pickup VIOLET wire to ground. When the VIOLET wire is grounded, the vehicle will crank but not start.

**Magnetic Pickup Trigger**

When using the mag pickup to trigger the MSD, install a switch to the WHITE wire and the other side to ground. When the WHITE wire is grounded, the vehicle will crank but will not start.

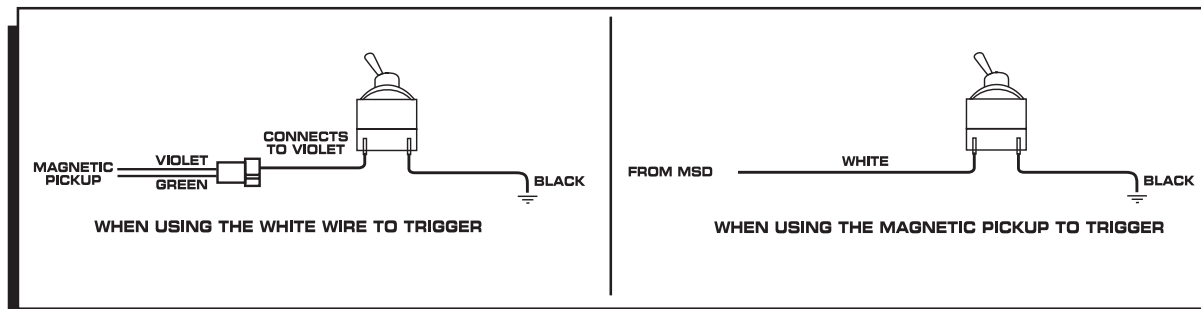

**Figure 5 Connecting a Theft Deterrent Switch Through the MSD Ignition.**

**4-PIN MODULE**

If the distributor is equipped with a 4-pin module, it will be removed. Use the supplied 2-pin wire connector to plug into the magnetic pickup of the distributor (Figure 6). This harness will be routed out of the HEI cap and will plug into the MSD's 2-pin magnetic pickup connector for its trigger signal.

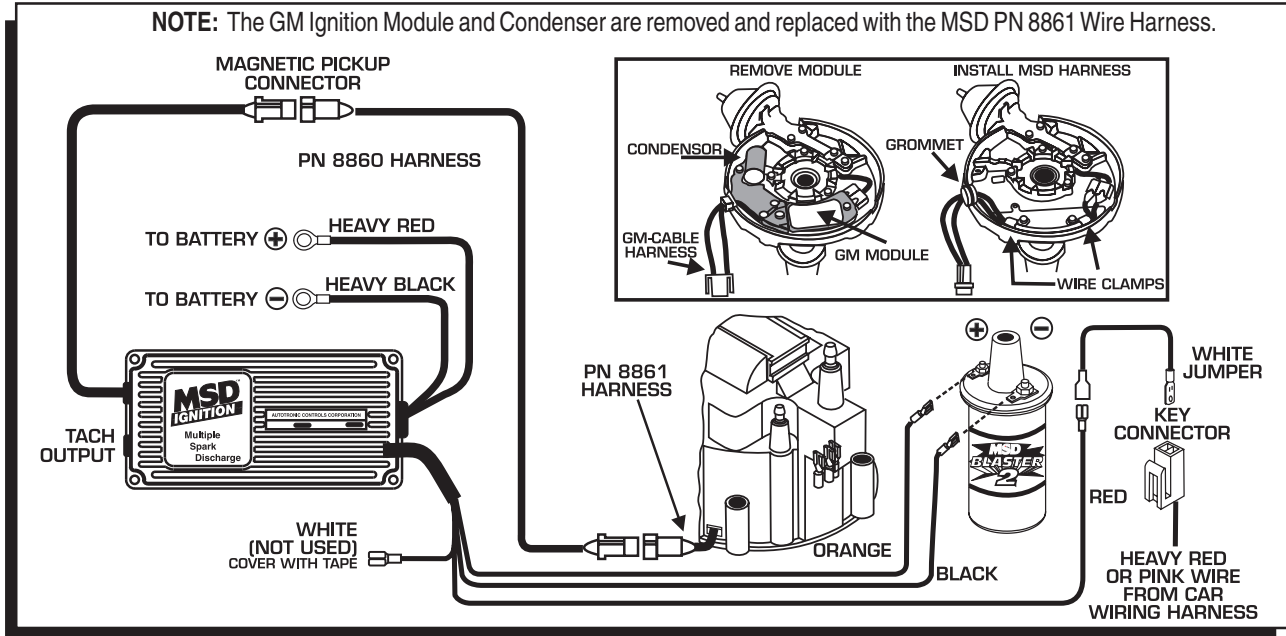

Figure 6 Wiring the MSD to a 4-Pin HEI Distributor.

**5 AND 7-PIN MODULES**

If the distributor is equipped with a 5 or 7-pin module, it will be left in the housing and the MSD will be triggered through the module on the MSD White wire. These modules have some amount of timing control so it is important to leave them in place. Figure 7 shows the wiring.

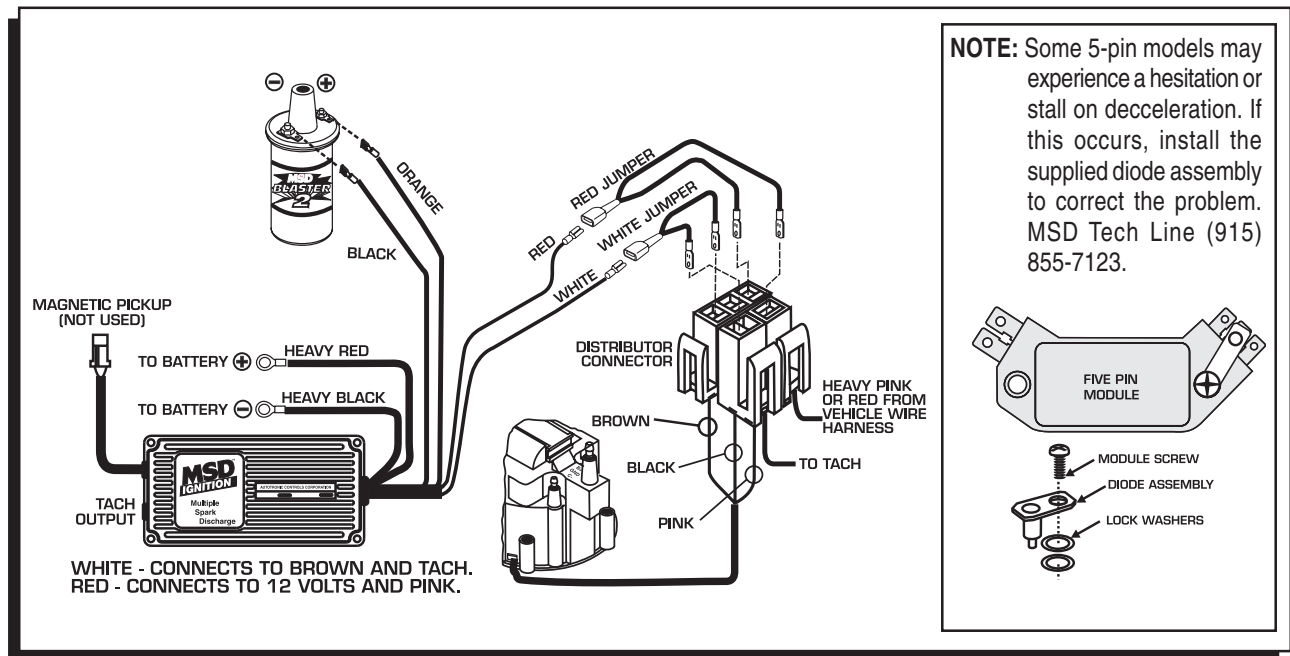

Figure 7 Wiring an HEI 5 or 7-pin Module (Amplifier Trigger).



**TROUBLESHOOTING**

Every MSD Ignition undergoes numerous quality control checks including a four hour burn-in test. If you experience a problem with your MSD, our research has shown that the majority of problems are due to improper installation or poor connections.

The Troubleshooting section has several checks and tests you can perform to ensure proper installation and operation of the MSD. If you have any questions concerning your MSD, call our Customer Support Department at (915) 855-7123, 8 - 5 mountain time.

**TACH ADAPTERS**

If your tachometer does not operate correctly or if you experience a no-run situation with your foreign vehicle you probably need an MSD Tach Adapter. The chart below lists common tachometers and if an Adapter is necessary.

<b>Tachometer Compatibility List</b>		
<b>AFTERMARKET TACHOMETER</b>	<b>WHITE WIRE TRIGGER</b>	<b>MAGNETIC TRIGGER CONNECTOR</b>
AUTOGAGE	8910	8920
AUTOMETER	NONE	NONE
MALLORY	NONE	NONE
MOROSO	NONE	NONE
STEWART (voltage triggered)	8910	8920
S.W. & BI TORX	NONE	NONE
SUN	8910	8920
VDO	8910	8920
GENERAL MOTORS	Bypass In-Line Filter	Bypass In-line filter
<p><b>Note:</b> On the list above, the trigger wire on the tachometers that are marked NONE may be connected to the Tach Output Terminal on the MSD 6 Series Ignition unit using the supplied Female Faston Receptacle.</p>		

**INOPERATIVE TACHOMETERS**

If your tachometer fails to operate with the MSD installed you may need an MSD Tach Adapter. Before getting an Adapter, try connecting your tachometer trigger wire to the tach output terminal on the side of the MSD. This output produces a 12 volt, square wave (see page 2). If the tach still does not operate, you will need a Tach Adapter. There are two Tach Adapters:

**PN 8920:** If you are using the Magnetic Pickup connector (Green and Violet wires) to trigger the MSD, you will need the PN 8920.

**PN 8910:** If your tachometer was triggered from the coil negative terminal (voltage trigger) and you are using the White wire to trigger the MSD you will need the PN 8910.

**ENGINE RUN-ON**

If your engine continues to run even when the ignition is turned Off you are experiencing engine Run-On. This usually only occurs on older vehicles with an external voltage regulator. Because the MSD receives power directly from the battery, it does not require much current to keep the unit energized. If you are experiencing run-on, it is due to a small amount of voltage going through the charging lamp indicator and feeding the small Red wire even if the key is turned off.

### GM 1973 - 1983 with Delcotron Alternators

GM Delcotron Alternators use an internal voltage regulator. Install the Diode in-line on the smallest wire exiting the alternator (Figure 8). It is usually a Brown wire.

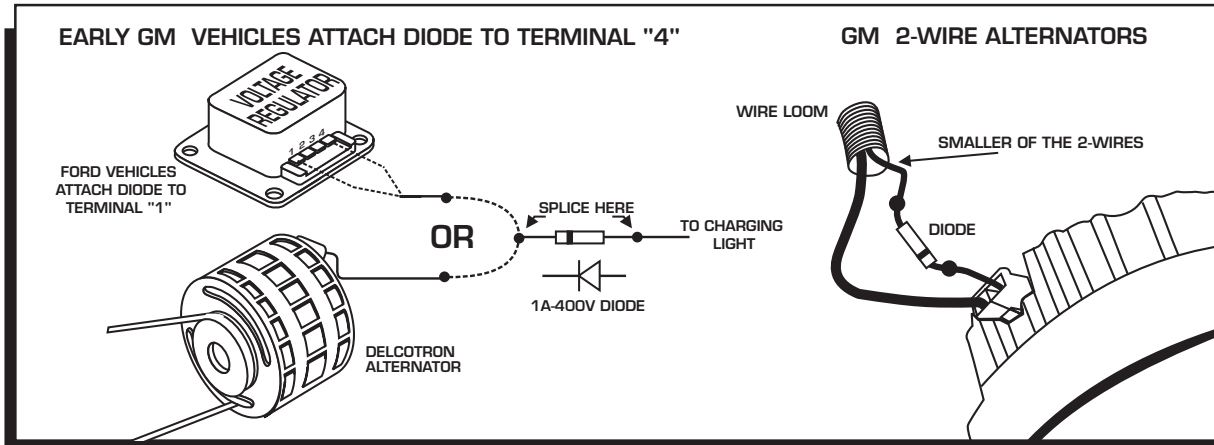

Figure 8 Installing the Diode to fix Run-On.

### MISSES AND INTERMITTENT PROBLEMS

Experience at the races has shown that if your engine is experiencing a miss or hesitation at higher rpm, it is usually not directly ignition. Most probable causes include a coil or plug wire failure, arcing from the cap or boot plug to ground or spark ionization inside the cap. Several items to inspect are:

- Always inspect the plug wires at the cap and at the plug for a tight connection and visually inspect for cuts, abrasions or burns.
- Inspect the Primary Coil Wire connections. Because the MSD is a Capacitive Discharge ignition and it receives a direct 12 volt source from the battery, there will not be any voltage at the Coil Positive (+) terminal even with the key turned On. During cranking or while the engine is running, very high voltage will be present and no test equipment should be connected.
- Inspect the rotor and rotor button of the distributor cap. Also make sure the secondary tower of the Modified Dust Cover is making good contact with rotor button.

**WARNING:** Do not touch the coil terminals during cranking or while the engine is running.

- Make sure that the battery is fully charged and the connections are clean and tight. If you are not running an alternator this is an imperative check. If the battery voltage falls below 10 volts during a race, the MSD output voltage will drop.
- Is the engine running lean? Inspect the spark plugs and complete fuel system.
- Inspect all wiring connections for corrosion or damage. Remember to always use proper connections followed by soldering and seal the connections completely.

If everything checks positive, use the following procedure to test the ignition for spark. MSD also offers an Ignition Tester, PN 8998. This tool allows you to check your complete ignition system while it is in the car as well as the operation of rpm limits, activated switches and shift lights.

**CHECKING FOR SPARK**

**If triggering the ignition with the White wire:**

1. Make sure the ignition switch is in the "Off" position.
2. Remove the coil wire from the distributor cap and set the terminal approximately 1/2" from ground.
3. Disconnect the MSD White wire from the distributor's points or ignition amplifier.
4. Turn the ignition to the On position. Do not crank the engine.
5. Tap the White wire to ground several times. Each time you pull the wire from ground, a spark should jump from the coil wire to ground. If spark is present, the ignition is working properly. If there is no spark skip to step 6 below:

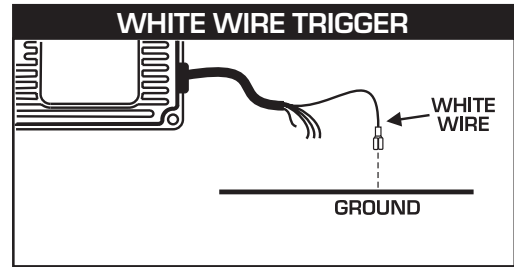

**Figure 9 Checking for Spark with the White Wire.**

**If triggering with the Magnetic Pickup:**

1. Make sure the ignition switch is in the "Off" position.
2. Remove the coil wire from the distributor cap and set the terminal approximately 1/2" from ground.
3. Disconnect the MSD magnetic pickup wires from the distributor.
4. Turn the ignition to the On position. Do not crank the engine.
5. With a small jumper wire, short the MSD's Green and Violet magnetic pickup wires together. Each time you break this short, a spark should jump from the coil wire to ground. If spark is present, the ignition is working properly. If there is no spark skip to step 6 below:

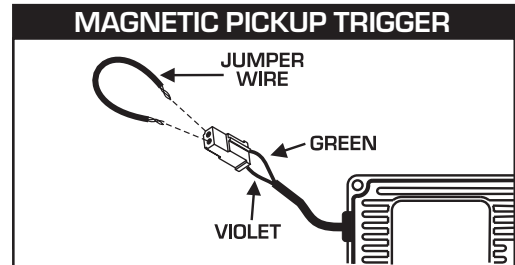

**Figure 10 Checking for Spark with Magnetic Pickup.**

**6. If there is no spark:**

- A. Inspect all of the wiring.
- B. Substitute another coil and repeat the test. If there is now spark, the coil is at fault.
- C. If there is still no spark, check to make sure there is 12 volts on the small Red wire from the MSD when the key is in the On position. If 12 volts is not present, find another switched 12 volt source and repeat the test.
- D. If, after following the test procedures and inspecting all of the wiring, there is still no spark, the MSD Ignition is in need of repair. See the Warranty and Service section for information.

The following wiring diagrams illustrate numerous installations on different vehicles and applications. If you experience difficulties when installing your MSD, contact our Customer Support Department at (915) 855-7123 (8 - 5 Mountain time) or e-mail us at: [msdtech@msdignition.com](mailto:msdtech@msdignition.com)



# INSTALLATION INSTRUCTIONS

## Service

In case of malfunction, this MSD component will be repaired free of charge according to the terms of the warranty. When returning MSD components for service, Proof of Purchase must be supplied for warranty verification. After the warranty period has expired, repair service is charged based on a minimum and maximum charge.

Send the unit prepaid with proof of purchase to the attention of: **Customer Service Department, Autotronic Controls Corporation, 12120 Esther Lama, Suite 114, El Paso, Texas 79936.**

When returning the unit for repair, leave all wires at the length in which you have them installed. Be sure to include a detailed account of any problems experienced, and what components and accessories are installed on the vehicle.

The repaired unit will be returned as soon as possible after receipt, COD for any charges. (Ground shipping is covered by warranty). All units are returned regular UPS unless otherwise noted. For more information, call the MSD Customer Service Line (915) 855-7123. MSD technicians are available from 8:00 a.m. to 5:00 p.m. Monday - Friday (mountain time).

## Limited Warranty

Autotronic Controls Corporation warrants MSD Ignition products to be free from defects in material and workmanship under normal use and if properly installed for a period of one year from date of purchase. If found to be defective as mentioned above, it will be replaced or repaired if returned prepaid along with proof of date of purchase. This shall constitute the sole remedy of the purchaser and the sole liability of Autotronic Controls Corporation. To the extent permitted by law, the foregoing is exclusive and in lieu of all other warranties or representations whether expressed or implied, including any implied warranty of merchantability or fitness. In no event shall Autotronic Controls Corporation be liable for special or consequential damages.