

MSD **IGNITION** **INSTALLATION INSTRUCTIONS**

MSD 7AL-3, Ignition Control PN 7230

Important: Read the instructions before attempting the installation.

Parts Included:

- 1 - 7AL-3, PN 7230
- 1 - Parts Bag (wires and connectors)
- 4 - RPM Modules 3000, 7000, 8000, 9000
- 4 - Retard Modules 2°, 3°, 4°, 4°
- 4 - Zero Degree Modules
- 4 - Vibration Mounts

WARNING: During installation, disconnect the battery cables. When disconnecting the battery, always remove the Negative cable first and install it last.

Note: The MSD 7AL-3 will retard the ignition timing approximately 4° compared to other MSD Ignitions. After installation, the timing should always be checked and adjusted at idle and total timing.

Note: This unit is designed for 8-cylinder engines only.

COIL RECOMMENDATIONS

The MSD 7AL-3 can be used with a variety of coils, but to receive the best performance, it is recommended to use an MSD Coil. For drag racing and “short duration” applications, the Pro Power Coil, PN 8201, is the best choice. For street applications or long duration racing events, the HVC Pro Power Coil, PN 8251 is recommended. The 7AL-3 may be used with a GM HEI Distributor with an internal coil, however the Rotor Bushing **must** be replaced with an MSD Low Resistance Bushing, PN 8412.

MOUNTING

The 7AL-3 can be mounted under the hood, but should be mounted in a position away from direct engine heat sources. Use the ignition as a template and mark the location of the mounting holes. Remove the unit and drill the holes using a 1/4" bit. Install the vibration mounts to the 7AL-3 then mount the ignition using the supplied lock washers and nuts.

WIRING

Wiring the 7AL-3 will be simple by following the instructions. There are several color coded wires supplied with the 7AL-3 and should be used as noted to avoid confusion or wrong connections. This section is also broken down into two sections; Primary Wiring and Optional Wiring.

- The Primary section designates the wires that must be connected to run the engine.
- The Optional Wiring section explains the wiring of optional built-in features such as the Rev Controls, RPM Activated Switch and Retard Controls.

WARNING: The 7AL-3 produces very high voltages. Never short the battery or coil terminals. Use caution during installation and while working near the ignition.

PRIMARY WIRING

WARNING: During installation, disconnect the battery cables. When disconnecting the battery, always remove the Negative cable first and install it last.

1. Begin wiring the MSD by connecting the wires responsible to run the engine. The terminal strip on the left side of the box is responsible for the Power Leads and the Coil Wires. Connect the supplied wires as follows:

Heavy Red: Connect from the “Batt +” terminal directly to the battery positive (+) terminal.

Heavy Black: Connect from the “Batt -” terminal directly to the battery negative (-) terminal.

Orange: Connect from the “Coil +” terminal to the positive terminal (+) of the coil.

Black: Connect from the “Coil -” terminal to the negative terminal (-) of the coil.

2. Move to the middle terminal strip and locate the terminal marked “Ignition”. Use the supplied RED wire and connect it to a switched 12 volt source (ignition switch).
3. If a retard function is not going to be used the supplied "zero" degree module must be installed or the terminals must be grounded. See the Multi-Step Retard Section.
4. The three terminals on the bottom of the middle terminal strip receive the trigger signal from the distributor. One terminal is for points style applications and the other two are for use with a magnetic pickup trigger, such as an MSD Billet Distributor or Crank Trigger.

Note: The Points and Mag Pickup terminals will never be connected at the same time.

Points: If you are using a Points style distributor or electronic amplifier, only the “Points” terminal will be used. Connect the supplied WHITE jumper wire from the points output in the distributor to the “Points” terminal (Figure 1).

Magnetic Pickup: If you are using an MSD Distributor or Crank Trigger, only the Magnetic Pickup terminals will be used. Locate the supplied harness with a VIOLET and GREEN wire with a 2-pin connector on one end. Connect the VIOLET wire to the “Mag +” terminal and the GREEN wire to the “Mag -” terminal then connect the 2-pin connector to the Distributor (Figure 1).

Note: The magnetic pickup wires must be routed away from all voltage carrying wires. A shielded 6-foot harness is available as PN 8862.

MAGNETIC PICKUP POLARITY

The MSD 7AL-3 can be used with other magnetic pick-up distributors as long as the wires are connected correctly. The chart on the right shows the polarity of some common magnetic pickups.

Common Mag Pickup Wires		
Distributor	Colors	
	Mag+	Mag-
MSD	Org/Blk	Vio/Blk
MSD Crank Trigger	Violet	Green
Ford	Orange	Purple
Accel ^{46/48000} Series	Org/Blk	Vio/Blk
Accel ^{51/61000} Series	Red	Black
Chrysler	Org/Wht	Black
Mallory	Org/Blk	Vio/Blk

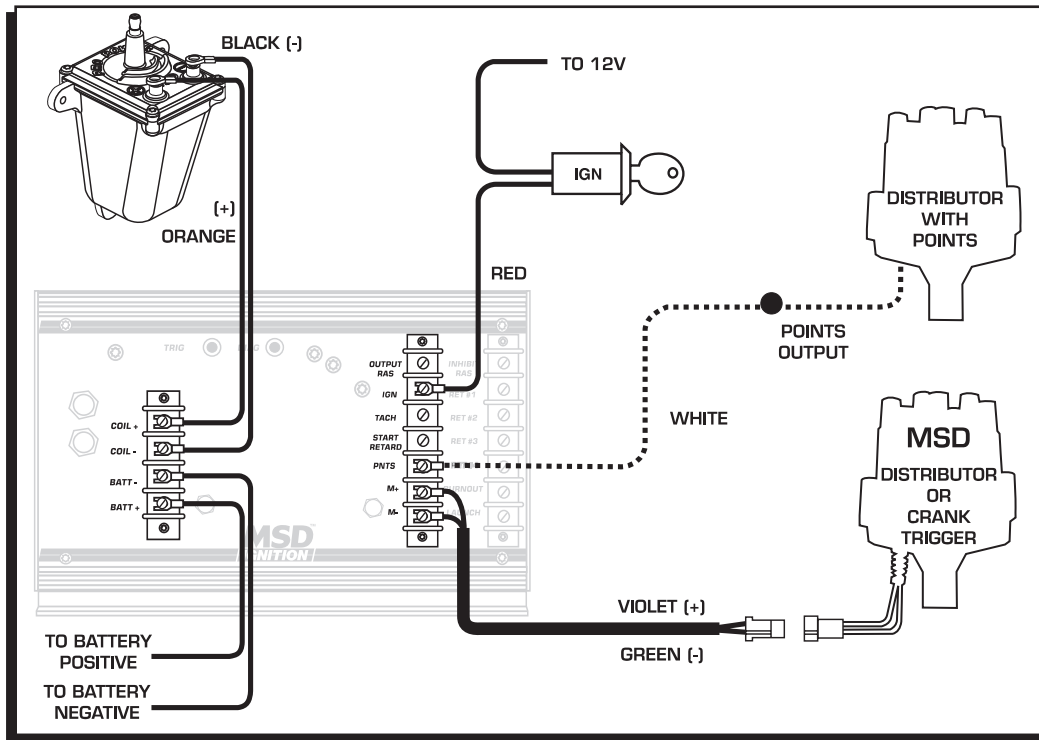

Figure 1 Wiring the Primary Side of the Ignition to Points or Magnetic Pickup.

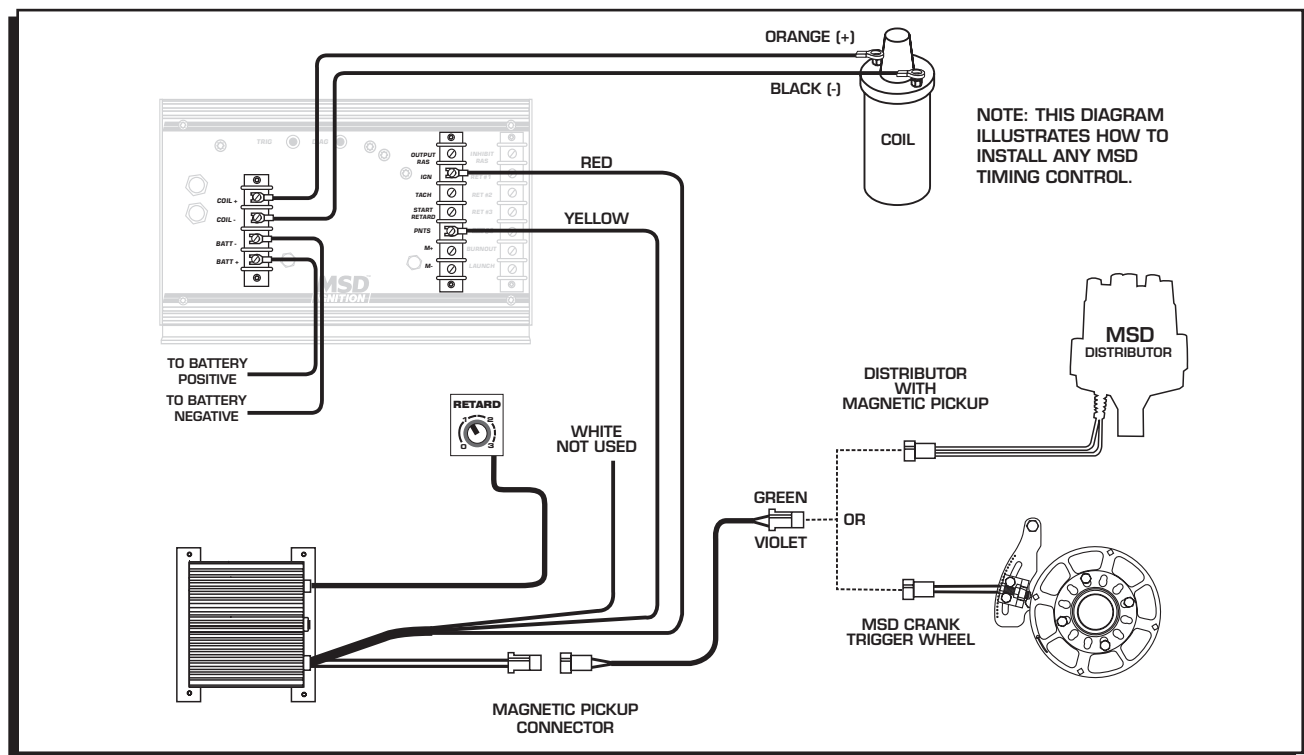

Figure 2 Primary Wiring to an MSD Timing or Boost Control and a Magnetic Pickup.

The following diagrams show the installation to a Mallory and an Accel BEI distributor.

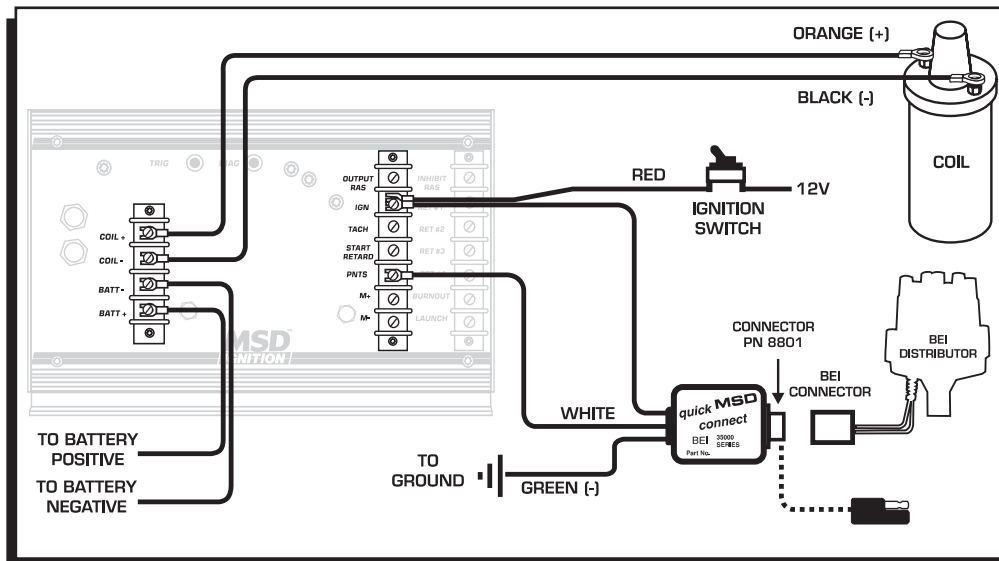

Figure 3 Primary Wiring to an Accel BEI Distributor.

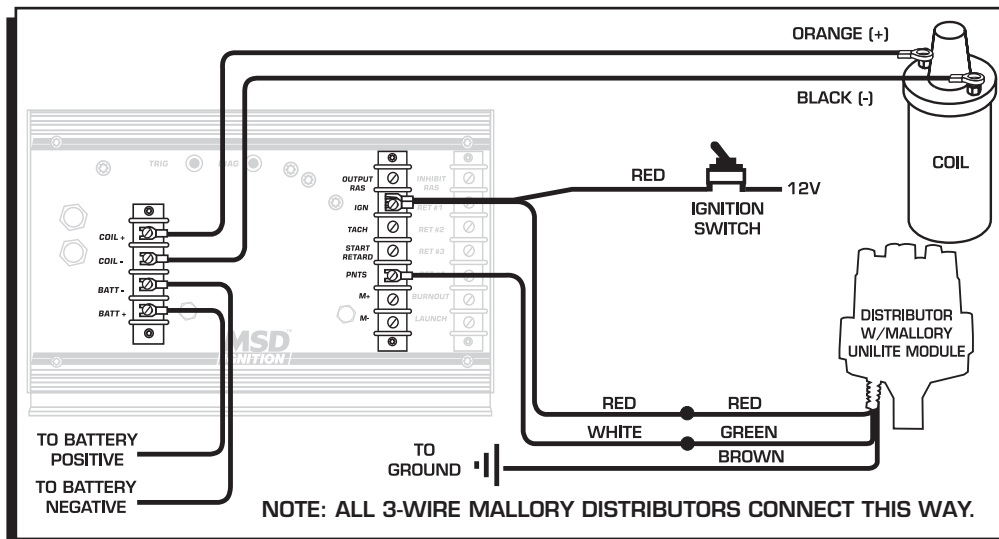

Figure 4 Primary Wiring to a Mallory Unilite Distributor.

Note: The MSD 7AL-3 will retard the ignition timing approximately 4° compared to other MSD Ignitions. After installation, the timing should always be checked and adjusted at idle and total timing.

GM HEI DISTRIBUTOR

The 7AL-3 can be wired to the GM HEI Distributor. You must identify which module your distributor has to determine which wiring diagram to use. Count the number of pins or terminals on the module.

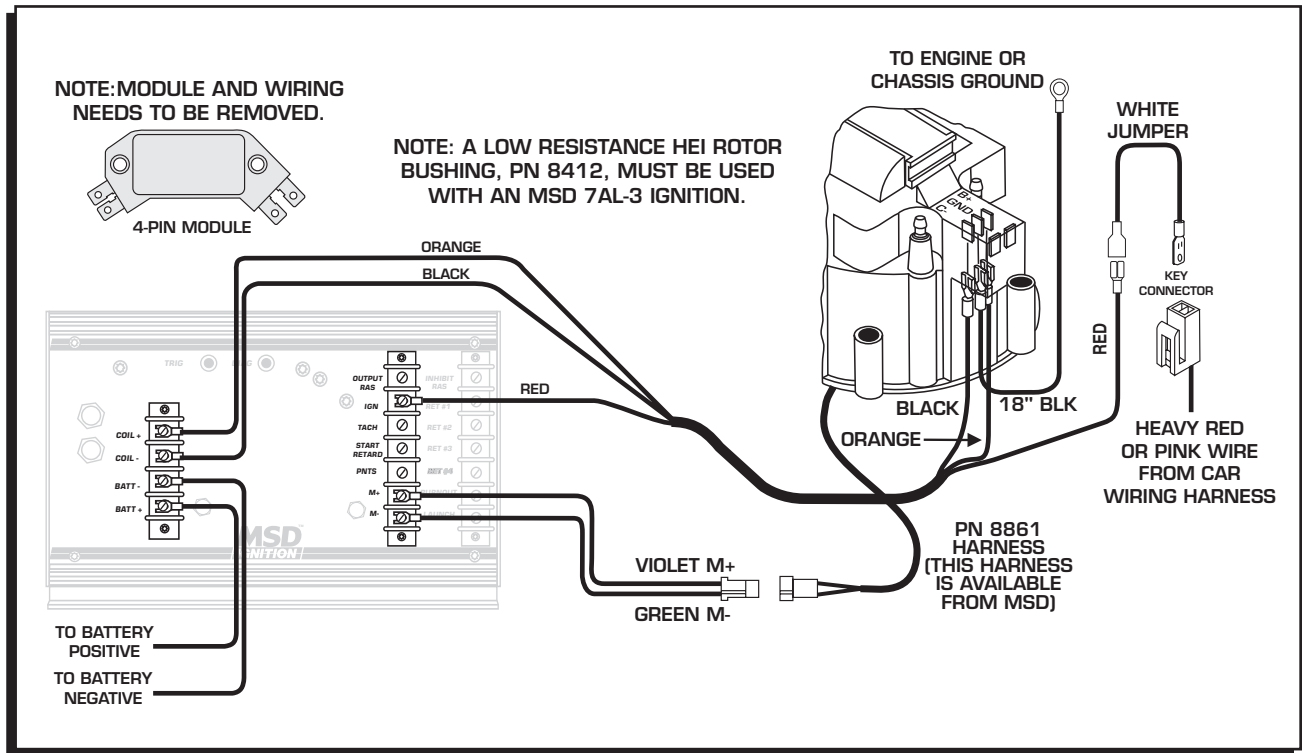

Figure 5 Primary Wiring to a GM HEI with a 4-Pin Module (Magnetic Pickup Trigger).

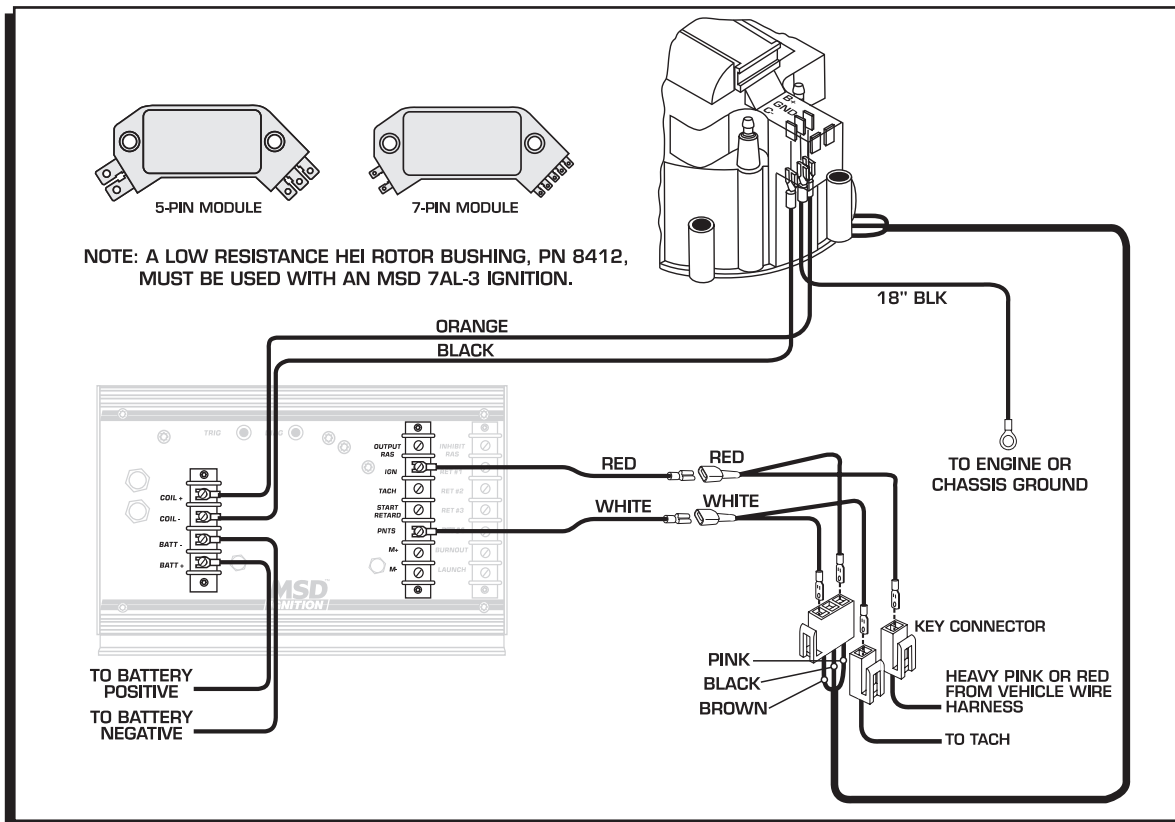

Figure 6 Primary Wiring to a GM HEI with a 5 or 7-Pin Module (Points Trigger).

OPTIONAL WIRING

This Wiring Section details the optional features of the MSD 7AL-3 and how to wire each system.

START RETARD

The Start Retard of the 7AL-3 is designed to ease starting on engines with locked timing, high compression and a lot of advance. When activated, the timing is retarded 25°. Some engine combinations benefit from this retard, while others may experience rough starting or starter kickback. If your engine experiences roughness with the start retard engaged, the retard is not necessary.

When activated, the Start Retard function will retard the ignition timing 25° while the engine is cranking which makes starting easier as well as saves wear and tear on the engine and the starter. This retard function will only operate below approximately 1,300 rpm. There are two different ways to connect this function (Figure 7):

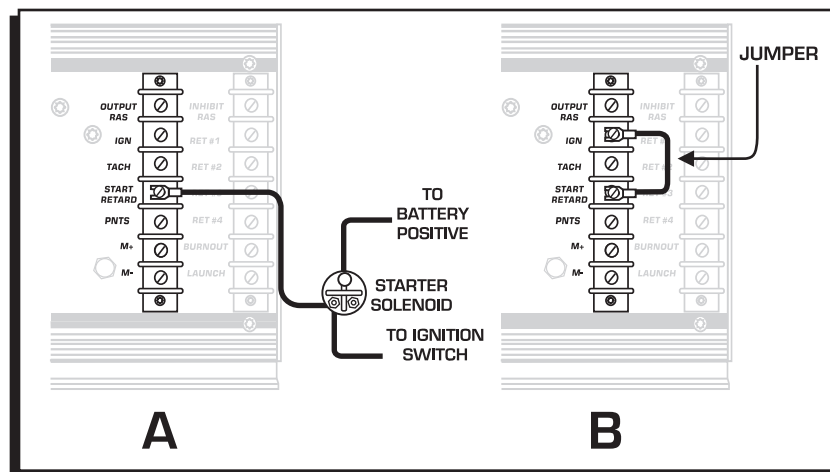

Figure 7 Wiring the Start Retard Function.

A. Switched 12 Volts

In this set up, the timing is retarded 25° only while the engine is cranking. Connect the supplied Violet wire from the "Start-Ret" terminal on the 7AL-3 to the starter solenoid. This way, 12 volts is only applied when the key or switch is in the cranking position. When the switch is released, 12 volts is removed and the timing returns to run timing.

B. Constant 12 Volts

In this setup, whenever the ignition is turned On, 12 volts is applied and the retard function is activated. The retard will be deactivated when the engine reaches about 1,300 rpm and will not occur again until the ignition is turned **Off**. Connect the supplied jumper from the Start-Ret terminal to the Ignition terminal of the terminal strip (two terminals up).

THREE STEP RPM LIMITS

The 7AL-3 has a built-in Three Step Module Selector which allows you to select up to three different rpm limits that occur at different times. The activation terminals are located on the bottom of the third terminal strip and are listed as Launch and Burnout. The third rpm limit is the high rpm, which is always active when there is an rpm module installed in the "Race" holder (except when the other rpm limits are activated).

These modules can be used in a variety of functions and are not limited to launches and burnouts. Each of the two optional rpm limits are activated when 12 volts is applied to their corresponding terminals (Figure 8). The 12 volts can come from switches, solenoids or relays giving you a variety of ways to activate the different rpm limits. The following steps illustrate a general drag race installation for use with a Burnout limit, Launch limit and Race limit.

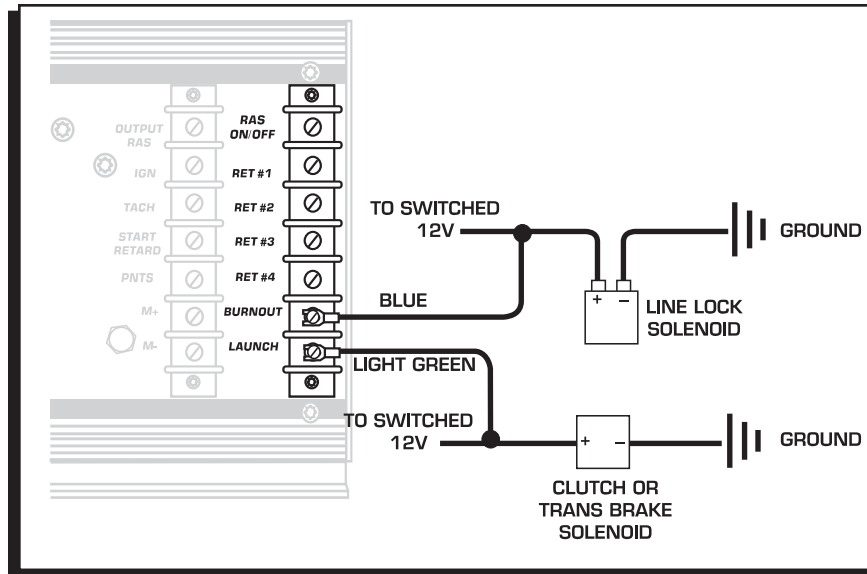

Figure 8 Connecting the Three Step Module Selector.

Note: Since the 7AL-3 is primarily a drag race ignition, the Launch limit is designed to override the Race and Burnout limits, even if the Burnout limit is activated at the same time.

Connecting the Three Step Function

1. Connect the supplied Blue wire from the Burnout terminal of the MSD to the 12 volt activation wire of the line lock solenoid. With this setup, when the line lock is activated, 12 volts will be supplied to the Burnout terminal which limits the rpm to your specified burnout rpm module.
2. Connect the supplied Light Green wire to the Launch terminal of the MSD then splice it into the clutch or trans brake 12 volt activation wire. This way, when the clutch pedal is depressed, 12 volts is applied to the Launch terminal which limits the rpm to your specified launch rpm module.

Note: The Launch rpm limit is designed to override the Burnout limit. This way, if you activate the line-lock on the starting line, when the Launch terminal is activated through the trans brake or clutch switch, the Launch rpm (not the Burnout limit) will be in effect. After the car launches the Race rpm limit is activated to protect the engine from over revving.

RPM ACTIVATED SWITCH

The RPM Activated Switch (RAS) Output will turn on a component such as a shift light or nitrous solenoid at an adjustable rpm point by supplying a ground path. The RPM Switch is capable of handling a 10 amp load. If 12 volts is required to activate the component, use an MSD Relay, PN 8960 or 8961.

The 7AL-3 also features an "RAS On/Off" for the RPM Activated Switch. To use the RPM Switch, 12 volts **must** be connected to the "RAS-On/Off" terminal located at the top of the third terminal strip. Whenever the 12 volts is removed from this terminal, the RPM Activated Switch **will not** operate.

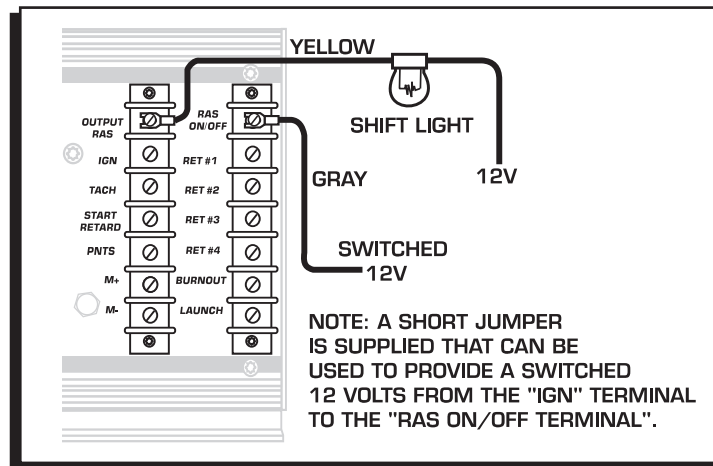

Figure 9 Connecting the RPM Activated Switch.

Basic Wiring: This example illustrates how to connect the RAS to activate a shift light at 7,000 rpm (Figure 9).

1. Connect the Gray wire to the RAS On/Off terminal and to a switched 12 volt source. This "prepares" the RAS circuit so when the desired rpm is reached the "Output Ras" will provide a ground to activate the light. A jumper is supplied to connect the "IGN" terminal to the RAS ON/OFF.
2. Connect the Yellow wire to the "RAS Output" terminal and the other end to the ground side of the shift light. **Note:** Twelve volts must be connected to the other side of the light.
3. Place a 7,000 rpm module in the RAS plug. When the engine reaches 7,000 rpm, a ground path for the shift light will be supplied and the light will turn on. **Note:** The light will remain on until the rpm falls 5% below the amount of the module. When you shift, the rpm drops and the light turns off until 7,000 rpm, when a ground path is again provided and the light turns on.

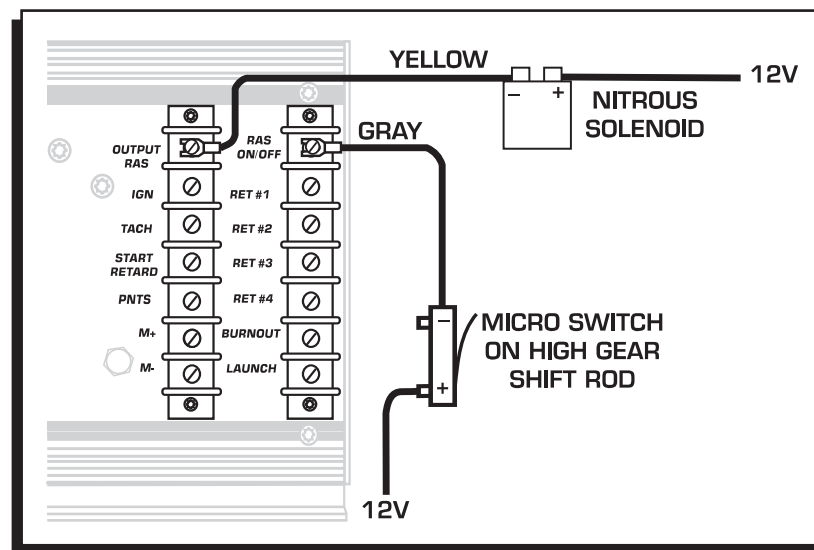

Figure 10 Activating the RAS in High Gear Only.

Incorporating the RAS On/Off: With the "RAS On/Off" terminal, you can control exactly when the RPM Switch is activated. This example illustrates how to turn on a nitrous solenoid at 5,000 rpm, but *only* when the car is in high gear (Figure 10). To do this, 12 volts must be applied to the "RAS On/Off" terminal *only* during high gear. This can be accomplished with a micro switch on the shifter.

1. Connect the Gray wire from the "RAS On/Off" terminal, to a micro switch that will close *only* when high gear is activated. The other side of the switch must have 12 volts.
2. Connect the supplied Yellow wire from the "Output RAS" terminal located at the top of the middle terminal strip, to the ground side of the nitrous solenoid. When the engine reaches 5,000 rpm in high gear, a ground path will be provided to the solenoid.
3. During the range of lower gears, even when the engine reaches over 5,000 rpm, the solenoid will not activate. When high gear is activated, the micro switch closes and 12 volts is applied to the "RAS On/Off" terminal which prepares the "Output RAS". The "Output RAS" provides a ground circuit for the nitrous solenoid. **Note:** The solenoid will remain activated until the micro switch removes the 12 volts from the "RAS On/Off" or until the rpm falls 5% below 5,000 (or whatever module is installed).

MULTI-STEP RETARD

There are four retard modules available with the 7AL-3. Each module is activated independently by removing ground from the corresponding module. The controlling terminals are listed as RET-1 through RET-4 and are located on the third terminal strip. The modules can be activated in any order and are cumulative unless deactivated. The maximum amount of retard allowed is a total of 20° even if the modules add up to more than 20°.

Note: If a Retard function is not going to be used the corresponding terminals must be grounded, or a "zero" degree module must be installed.

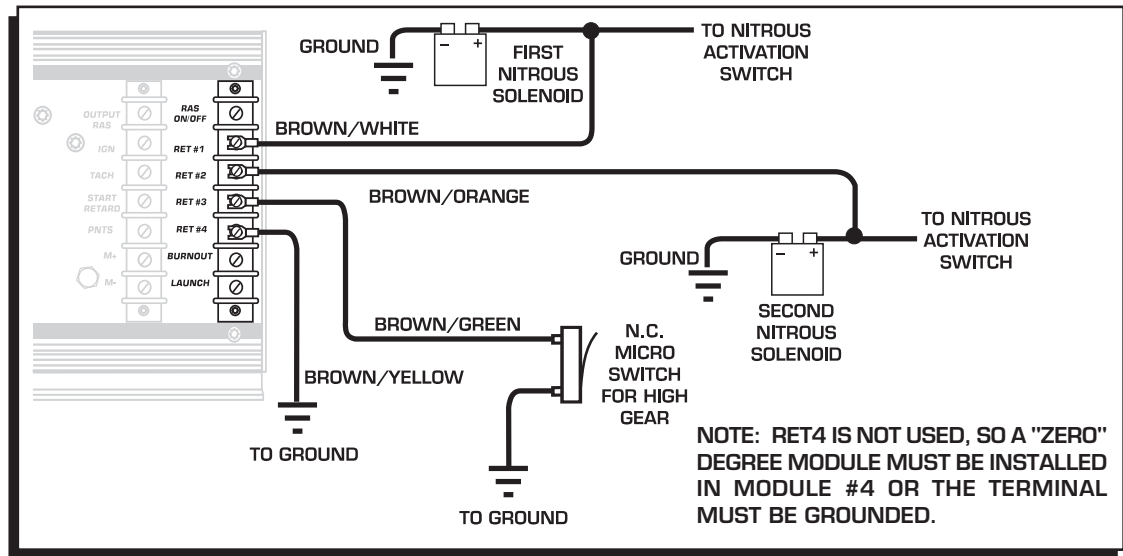

Figure 11 Connecting the Multi-Step Retard.

Connecting the Multi-Step Retard Function

In this example, we will connect three of the four retard modules (Figure 11). One to the first nitrous solenoid, another to the second nitrous solenoid and a third for a high speed retard that engages when high gear is pulled.

Note: By connecting to the 12 volt source side of the nitrous solenoid, the wire receives ground through the windings of the solenoid.

1. Connect the supplied Brown/White wire from the RET-1 terminal to the 12 volt source side of the number one nitrous solenoid. With the solenoid not activated, the wire will be grounded through the solenoid. When 12 volts is applied to activate the solenoid, the ground will be removed which will activate RET-1.

2. Connect the Brown/Orange wire from the RET-2 terminal to the 12 volt source side of the number two nitrous solenoid. When the second solenoid is activated the ground is removed and the RET-2 module is activated.

Note: Since the number one solenoid remains on, the first and second retard modules are now activated and their retard amounts are added together.

3. To activate RET-3, the Brown/Green wire is connected from the RET-3 terminal to a normally closed (N.C.) microswitch on the shifter. When the shifter is pulled into high gear, the switch removes the wire from ground which activates the third retard. The total sum of the three retard amounts are now activated.

4. Since RET-4 is not being used, a "zero" degree module must be installed, or the terminal must be grounded.

RETARD WITH THE RPM ACTIVATED SWITCH

The MSD 7AL-3 has both an RPM Activated Switch (RAS) and a Multi-Step Retard. The stages of retard are activated when the corresponding activation wire is *removed* from ground. The RAS can only activate a circuit by *providing a ground path*.

If you want to use the RAS to activate a retard stage of the 7AL-3, an external relay must be used. The MSD Relay, PN 8961, is supplied in the parts bag with the 7AL-3. Figure 12 shows how to connect the relay for this application. RET 1 is grounded through terminals 30 and 87A of the Relay while the relay is off. Terminal 86 receives 12 volts from the ignition terminal and when the desired rpm is activated, a ground path is supplied to terminal 85 which turns the relay On, activating the retard.

Note: Make sure 12 volts is applied to the RAS On/Off terminal.

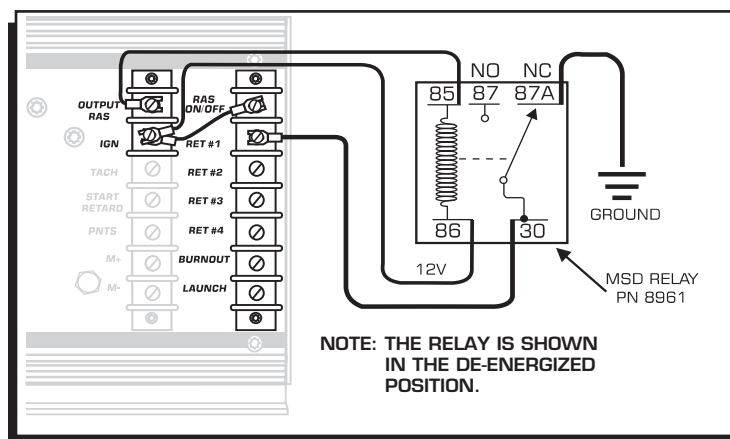

Figure 12 Using the RAS to Activate a Retard.

TACHOMETER

This terminal provides a square wave 12 volt, 20% duty cycle signal for your tachometer. Use the supplied Brown wire and connect it to the Tach terminal strip (Figure 13). If your tachometer reads erratic or does not operate properly, a Tach Adaptor may be required. If you are using the white wire to trigger (points input) you will need Adapter PN 8910. If you are using the magnetic pickup, PN 8920 will be the right Adapter. Contact your MSD dealer.

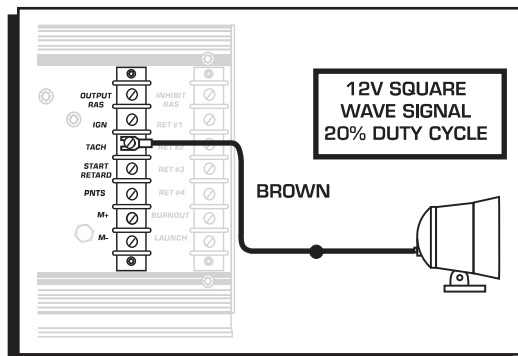

Figure 13 Connecting a Tachometer.

KILL SWITCH

If your racing application requires an ignition kill switch (dead man's switch) it is easy to incorporate into the ignition's trigger input wire. When the trigger input terminal is grounded, the ignition is killed. A Single-Pole, Single Throw Switch is required (MSD PN 8806).

Points: Connect one side of the switch to ground and the other side to the Points terminal of 7AL-3 (Figure 14).

Mag Pickup: Connect one side of the switch to ground and the other side to the Mag+ terminal of 7AL-3 (Figure 15).

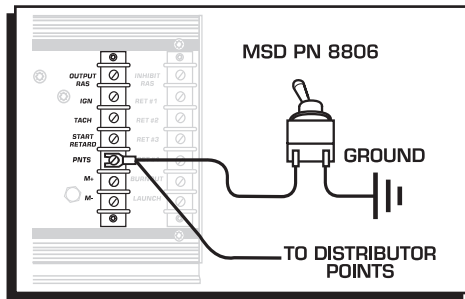

Figure 14 Connecting a Kill Switch to Points.

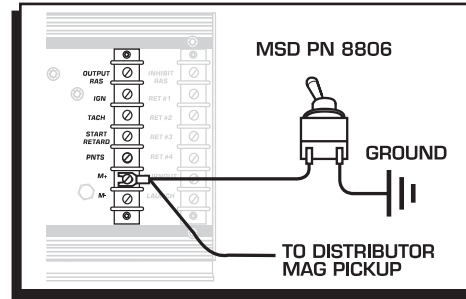

Figure 15 Connecting the Kill Switch to the Mag+.

TROUBLESHOOTING

If for some reason you suspect that the ignition system is not functioning properly, follow the proceeding procedures to determine if the MSD is functioning properly.

DIAGNOSTIC LED

The MSD 7AL-3 is equipped with two LEDs; one Green, one Red.

Green: The Green LED indicates that the ignition is operating properly and is receiving a trigger signal. If it is not operating, the trigger mechanism, either crank trigger or distributor, is not delivering a trigger signal. If the engine will not run though the Green LED shows a trigger signal, follow the "Checking for Spark" procedure on page 12.

Red: The Red LED is a safety or warning function. If it turns on, a problem within the ignition is occurring. If the Red Led is on, inspect the wiring and connections. If everything checks okay, the ignition needs to be sent to the factory for inspection/repairs.

MSD offers an Ignition Tester, PN 8998, that will check the Ignition and Coil's operation. (The obsoleted Tester PN 8995, can only be used on the points input.)

WIRING CHECK

WARNING: The 7AL-3 produces very high voltages. Never short the battery or coil terminals. Use caution during installation and while working near the ignition.

- Check all of the wire connections making sure they are clean and tight. If connectors have been crimped on make sure they are tight and sealed.
- Make sure the battery is fully charged and properly connected. Also confirm that the MSD power leads are connected properly and are tight.
- With a test light check that there is voltage on the RED "Ignition" terminal of the MSD when the ignition is in both the On and START position.
- Check that the only wires connected to the coil are from the MSD. ORANGE should connect to the positive terminal, BLACK to the negative terminal.

Note: DO NOT connect any test equipment to the coil terminals.

After checking the wiring for loose or faulty connections, follow the next steps to confirm that the unit is "sparking" properly.



INSTALLATION INSTRUCTIONS

CHECKING FOR SPARK

The following procedures will determine if the ignition is producing a spark. Before proceeding, inspect all of the wiring and ensure that the Green LED is flashing when the engine is cranked. This ensures that the ignition is receiving a trigger signal .

Magnetic Pickup (Green and Violet):

1. Make sure the ignition is turned OFF and remove the coil wire from the distributor cap. Pull the boot back so the terminal is easy to see and position the wire 1/2" from ground.
2. Disconnect the magnetic pickup connector from the distributor.
3. Turn the ignition switch to the ON position. **DO NOT CRANK THE ENGINE.**
4. Take a short length of wire and short the Green and Violet wires together then pull the wire away. A spark should jump from the coil wire to ground every time the connection is broken.
5. If there is no spark, substitute another coil and test again. If there is still no spark and all of the wiring connections have been confirmed, contact the MSD Customer Service Line and send the unit in for repair.

White Wire Trigger:

1. Make sure the ignition is turned OFF and remove the coil wire from the distributor cap. Pull the boot back so the terminal is easy to see and position the wire 1/2" from ground.
2. Disconnect the White wire from the distributor.
3. Turn the ignition switch to the ON position. **DO NOT CRANK THE ENGINE.**
4. Tap the White wire to ground several times. A spark should jump from the coil wire to ground when the white wire is removed from ground.
5. If there is no spark, substitute another coil and test again. If there is still no spark and all of the wiring connections have been confirmed, contact the MSD Customer Service Line and send the unit in for repair.

Service

In case of malfunction, this MSD component will be repaired free of charge according to the terms of the warranty. When returning MSD components for warranty service, **Proof of Purchase** must be supplied for verification. After the warranty period has expired, repair service is based on a minimum and maximum fee.

All returns must have a Return Material Authorization (RMA) number issued to them before being returned. To obtain an RMA number please contact MSD Customer Service at 1 (888) MSD-7859 or visit our website at www.msdisignition.com/rma to automatically obtain a number and shipping information.

When returning the unit for repair, leave all wires at the length in which you have them installed. Be sure to include a detailed account of any problems experienced, and what components and accessories are installed on the vehicle. The repaired unit will be returned as soon as possible using Ground shipping methods (ground shipping is covered by warranty). For more information, call MSD Ignition at (915) 855-7123. MSD technicians are available from 7:00 a.m. to 6:00 p.m. Monday - Friday (mountain time).

Limited Warranty

MSD IGNITION warrants this product to be free from defects in material and workmanship under its intended normal use*, when properly installed and purchased from an authorized MSD dealer, for a period of one year from the date of the original purchase. This warranty is void for any products purchased through auction websites. If found to be defective as mentioned above, it will be repaired or replaced at the option of MSD Ignition. Any item that is covered under this warranty will be returned free of charge using Ground shipping methods.

This shall constitute the sole remedy of the purchaser and the sole liability of MSD Ignition. To the extent permitted by law, the foregoing is exclusive and in lieu of all other warranties or representation whether expressed or implied, including any implied warranty of merchantability or fitness. In no event shall MSD Ignition or its suppliers be liable for special or consequential damages.

*Intended normal use means that this item is being used as was originally intended and for the original application as sold by MSD Ignition. Any modifications to this item or if it is used on an application other than what MSD Ignition markets the product, the warranty will be void. It is the sole responsibility of the customer to determine that this item will work for the application they are intending. MSD Ignition will accept no liability for custom applications.