

# MSD INSTALLATION INSTRUCTIONS

## MSD 6M-2/MSD Off-Road Ignition To GM Dual Connector Coil Harness PN 64602

### Parts Included:

1 - Harness

1 - Instruction Manual

**WARNING:** During installation, disconnect the battery cables. When disconnecting, always remove the negative cable first and install it last.

This harness is designed to provide a splice free and simple installation of an MSD 6M-2 Marine Ignition Control, PN 6460, or MSD 6-Offroad Ignition, PN 6470 to engines equipped with GM's dual Connector Coil (Figure 1).

**Note:** In some cases, an MSD Tach/Fuel Adapter may be required for correct tachometer and fuel injection operation, there is also a connector for the Adapter, PN 8910.

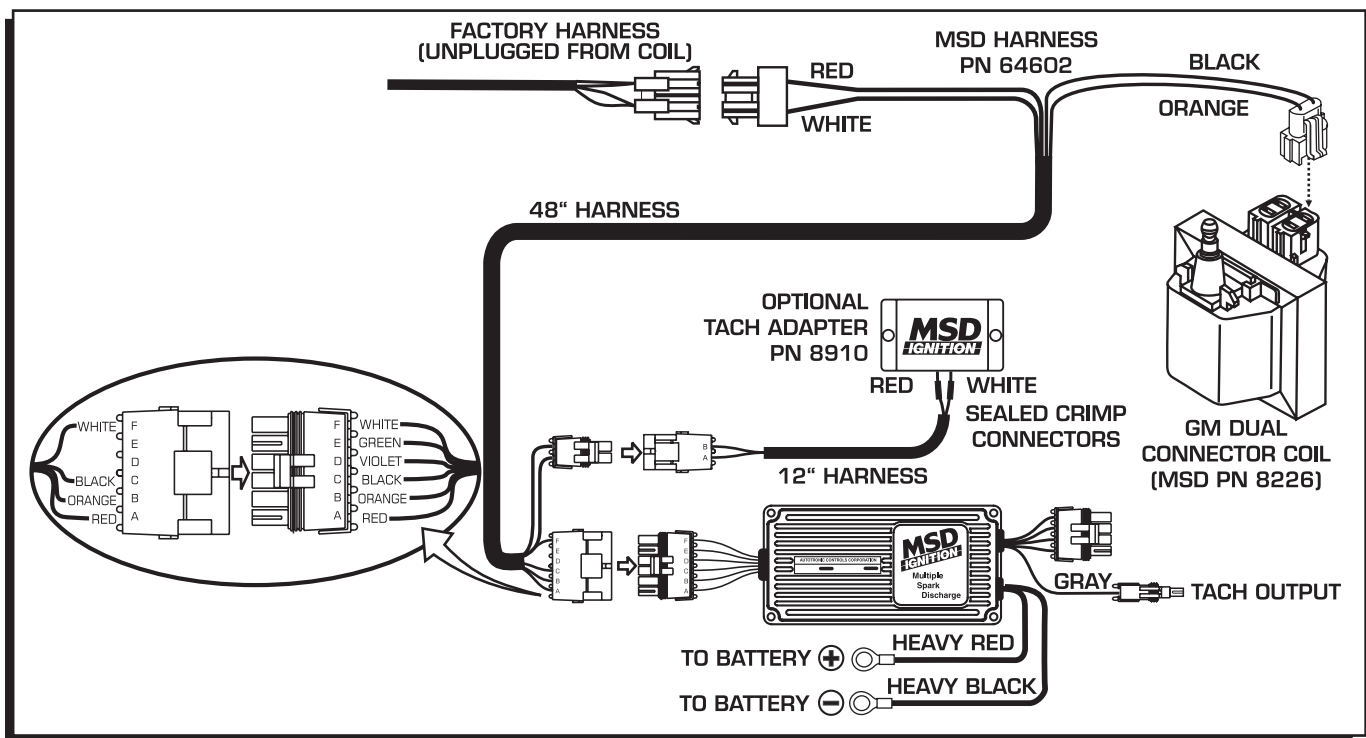

Figure 1

All of the connectors plug directly into the corresponding connectors on the ignition and coil (Figure 1).

1. Disconnect the Gray connector followed by the Black connector from the coil.
2. Connect the Black then the Gray connector to the MSD PN 64602 Harness.
3. Connect the other end of the harness to the coil. Note: the connector will only fit on one side of the coil. Only two wires go to the coil with an MSD Ignition Control installed.
4. Connect the 6-Pin Weathertight connector to the MSD Control.
5. If your application requires an MSD Tach/Fuel Adapter, Connect the remaining 2 Black wires to the MSD Adapter.

