

INSTALLATION INSTRUCTIONS

The ACCEL Electronic Super Coil is a bolt-in high performance automotive coil which replaces original equipment coils for electronic computer ignition without cutting or splicing of your vehicle's wiring harness. The red and black leads of the factory-style ACCEL harness connectors are identified for easy hook-up to the Super Coil.

Reading these instructions before starting the installation will assure that you will be able to take maximum advantage of all the performance that your ACCEL Electronic Super Coil was designed to deliver.

Due to the high energy output, the Electronic Super Coil is supplied with ACCEL's 8.8mm coil wire. The extruded aluminum housing/bracket is designed with cooling fins for efficient heat dissipation. Mounting hardware kit is included.

STEP 1

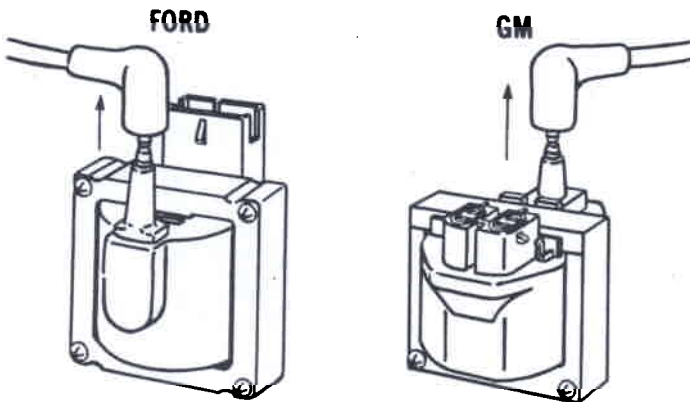

Locate stock factory Ignition coil and remove coil wire.

STEP 2

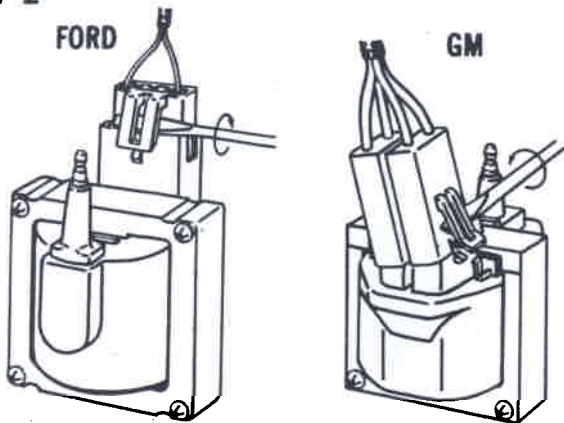

Remove electrical connector by carefully inserting a screwdriver between the connector lock tabs and with a twisting motion carefully pull outward.

NOTE: You might need to release one side at a time.

STEP 3

Remove the mounting screws and remove stock coil.

STEP 4

Choose an area on the fire wall or fender well where the coil may be mounted with no interference from linkage, air conditioning lines, heater hoses, etc. and no further than 24" from the distributor. (Please note that the ACCEL Electronic Super Coil may not fit into your original mounting location.)

CAUTION: Before drilling holes, please check and be aware of what you are drilling into. Be sure not to damage a component that may be under or in line with a mounting hole.

STEP 5

The ACCEL Wiring Harness is supplied with two terminated ends, one GM, one Ford, as per the below illustration. Cut off the end that is not needed for your application and discard.

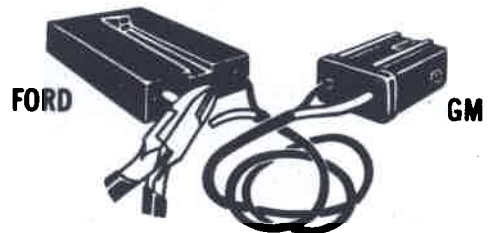

NOTE: On some Ford installations, the stock harness connector can be plugged directly into the new coil depending on the mounting location distance.

STEP 6

Carefully plug the ACCEL connector into the original factory harness connector. DO NOT FORCE. The ACCEL connector is designed to be inserted only one way.

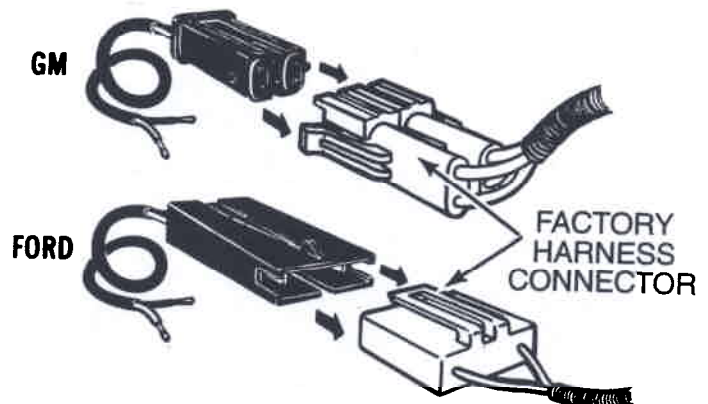

STEP 7

The Super Coil comes with a gray pigtail connector. This pigtail must be spliced to the ACCEL wire harness using the insulated butt splice connectors supplied in the hardware kit. Crimp the two red wires together, and, the green with yellow stripe and black wires together. Using a heat gun or a torch, carefully heat the insulated butt splices to shrink the sleeve and make a weather tight seal. Plug the gray connector into the Super Coil. **DO NOT FORCE.** The connector is designed to be inserted only one way.

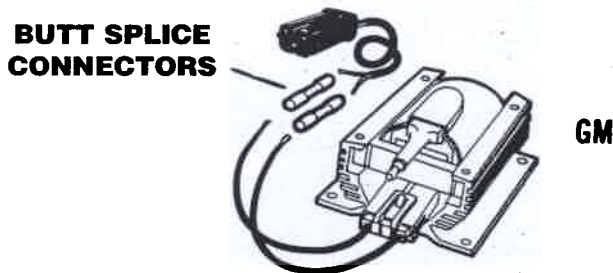
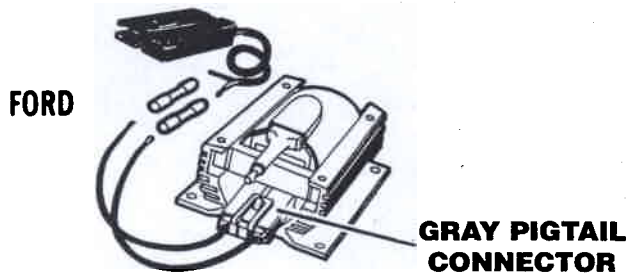

NOTE: CAREFULLY ROUTE THE ACCEL COIL HARNESS AWAY FROM ANY LINKAGE, AIR CONDITION LINES, HEATER HOSES, EXHAUST MANIFOLDS, ETC. BY USING THE MOUNTING HARDWARE INCLUDED IN THE KIT.

STEP 8

MEASURE COIL WIRE TO CORRECT LENGTH
Connect the ACCEL 8.8mm coil wire to the Super Coil and measure the length needed to the distributor cap. Once determined, cut and terminate with supplied terminals. (See Step 9)

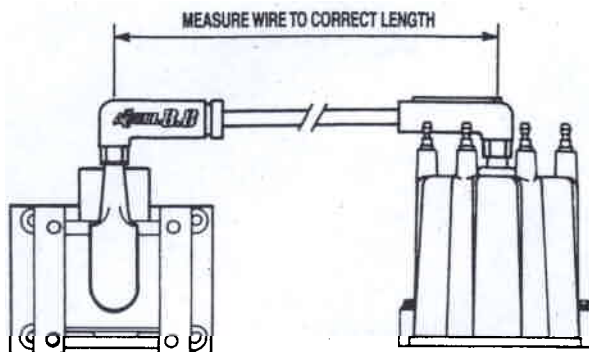

STEP 9

Carefully strip wire to expose 1/2 to 5/8 inch of conductor.

DO NOT SLIT CORE



DO NOT SHRED OR STRIP AWAY CORE



A. Bend conductor over wire and insert into terminal.



B. Bend terminal tabs over with pliers and/or ignition wire crimping tool.



C. Lightly lubricate the terminal with the dielectric grease included and slide the wire into the HEI boot.

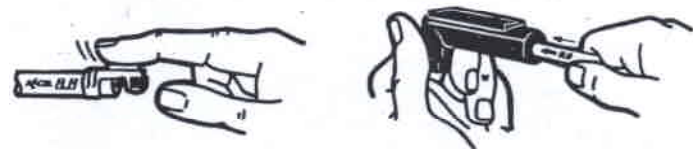

D. Small amounts of dielectric grease may also be applied inside of boots on both spark plug and distributor cap ends to stop any high voltage leakage.

E. Be sure you have made a good connection in the distributor cap and coil. You should recheck these connections periodically. If connector in distributor cap or coil is gray-green, "or appears corroded" you may have a poor connection.

Once all steps have been completed and final checks have been made on mounting and wiring, your ignition system is ready for operation.