



Part # 11530311 - 1968-1979 C3 Corvette Level 3 CoilOver System

Recommended Tools

Front Components:

11539599 Front TruTurn Package Instructions
11533511 Front TQ Series CoilOver Instructions
11539100 Front MuscleBar

Rear Components:

11537199 Rear StrongArm Package
11536511 Rear TQ Series Coilover Instructions
11539102 Rear MuscleBar

Miscellaneous Components:

85000000 Spanner Wrench

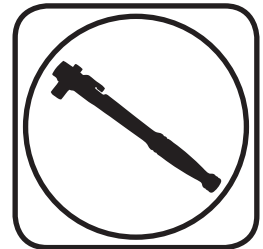

1968-1979 C3 Corvette Level 3 Coilover Installation Instructions

Table of contents

Pages 2-14 Front TruTurn Package
Pages 15-19 Front CoilOvers
Pages 20-26 Front MuscleBar
Pages 27-34 Rear StrongArm Kit
Pages 35-38..... Rear CoilOvers
Pages 39-45..... Rear MuscleBar





Part # 11539599 - 1968-1982 C3 Front TruTurn System

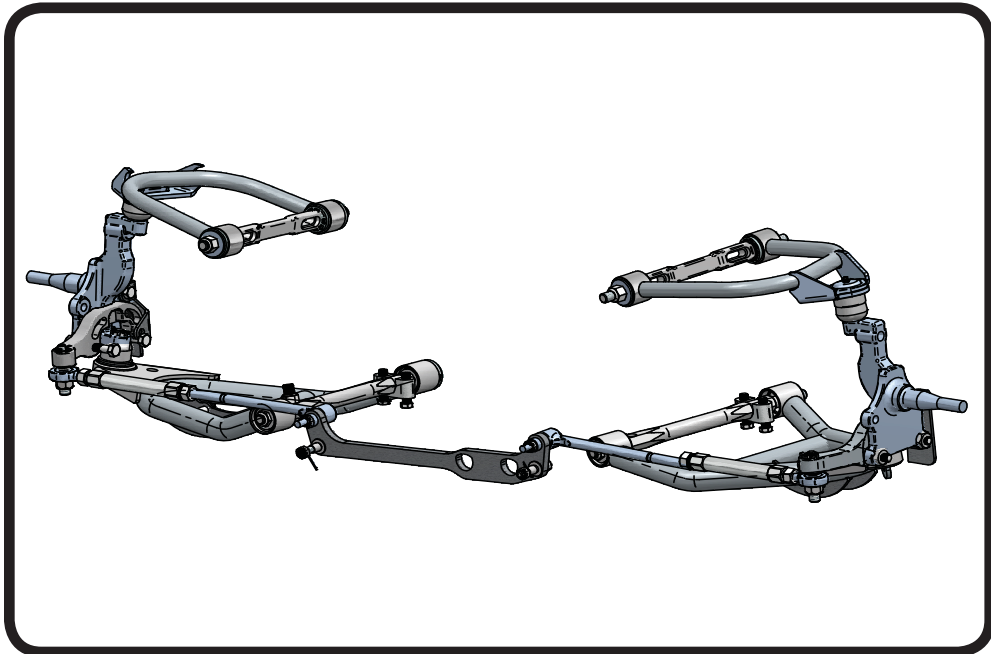

Recommended Tools



1968-1982 C3 Front TruTurn System

Installation Instructions

Table of contents

- Page 3..... Included components
- Page 4..... Upper Control Arm Components
- Page 5..... Lower Control Arm Components
- Page 6..... TruTurn Steering Components
- Page 7..... Misc Hardware List and Getting Started
- Page 8..... Installing Lower and Upper Control Arm
- Page 9..... Caster Explained
- Page10..... Offset Upper Cross Shaft
- Page11..... Installing Upper Control Arm and Spindle
- Page12..... Installing TruTurn System
- Page13..... Tie-Rod Assembly and Installation
- Page14..... The Finish



Major ComponentsIn the box

Item #	Part #	Description	QTY
1	90002161	Driver Upper Control Arm	1
1	90002162	Passenger Upper Control Arm (Not Shown)	1
2	90002159	Driver Lower Control Arm	1
2	90002160	Passenger Lower Control Arm (Not Shown)	1
3	11009300	Tall Spindle (Driver and Passenger)	1pr
4	90002173	Driver Steering Arm	1
4	90002174	Passenger Steering Arm (Not Shown)	1
5	90002171	Driver Steering Stop	1
5	90002172	Passenger Steering Stop (Not Shown)	1
6	90002170	Draglink Adapter	1
7	70011885	Inner Tie-Rod	2
8	90000728	Tie-Rod Adjuster	2
9	90001582	Heim End (used On Tie-Rod)	2
10	90009931	Outer Tie Rod Stud	2
11	90009932	Steering Arm Tapered Nut	2
12	90009933	Draglink Stud	2
13	90002373	Tie Rod Stud Lock Nut Spacer	2

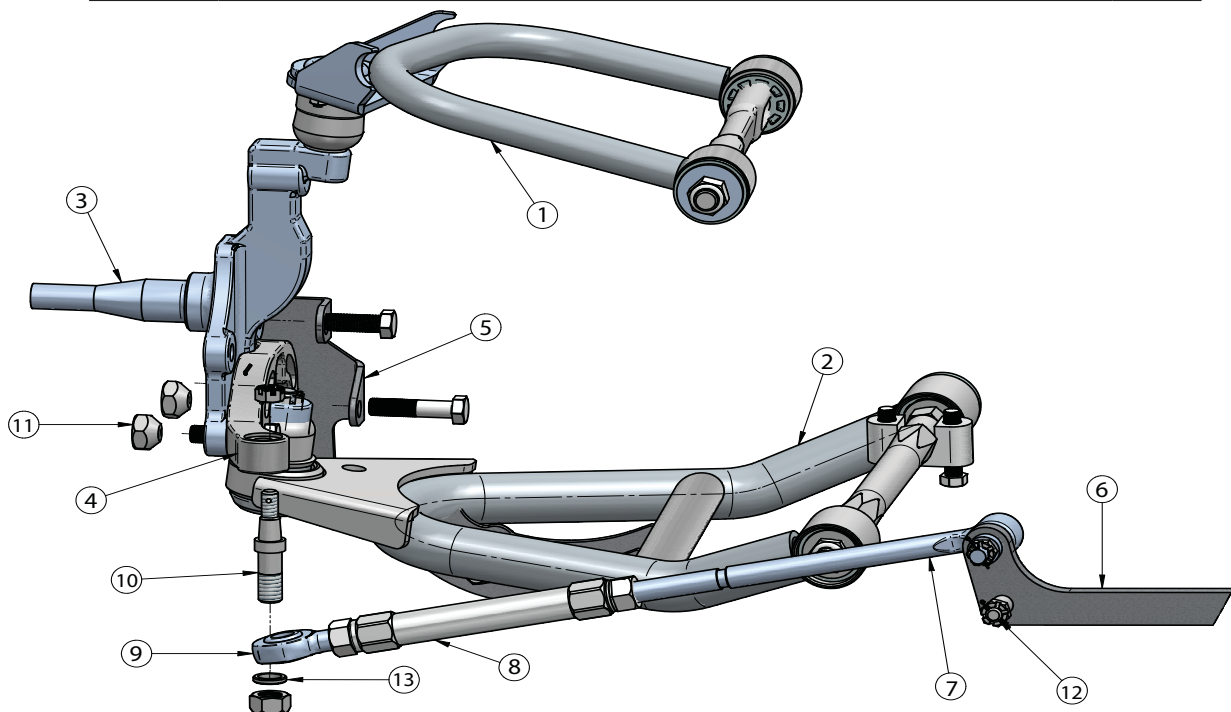



Upper Control Arm ComponentsIn the box

Item #	Part Number	Description	QTY
1	90000908 Kit	Upper Balljoint Assembly	2
2	90002161	Driver Upper Control Arm (Shown)	1
2	90002162	Passenger Upper Control Arm	1
3	70010826	Inner Delrin Bushing - No Ledge	2
4	70010759	Outer Delrin Bushing	4
5	90000914	Caster Adjustable Upper Control Arm Shaft	2
6	70011955	Caster Slug	4
7	99163001	Outer 2.0" OD Washer	4
8	99622005	5/8 - 18 Thin Locknut	4
9	70010827	Inner Delrin Bushing - with Ledge	2
	99432001	7/16" -14 Nylok Nut - Upper Mounting Bolt (Not Shown)	4
	99433002	7/16" SAE Flatwasher - Upper Mounting Bolt (Not Shown)	4

Driver Side Shown

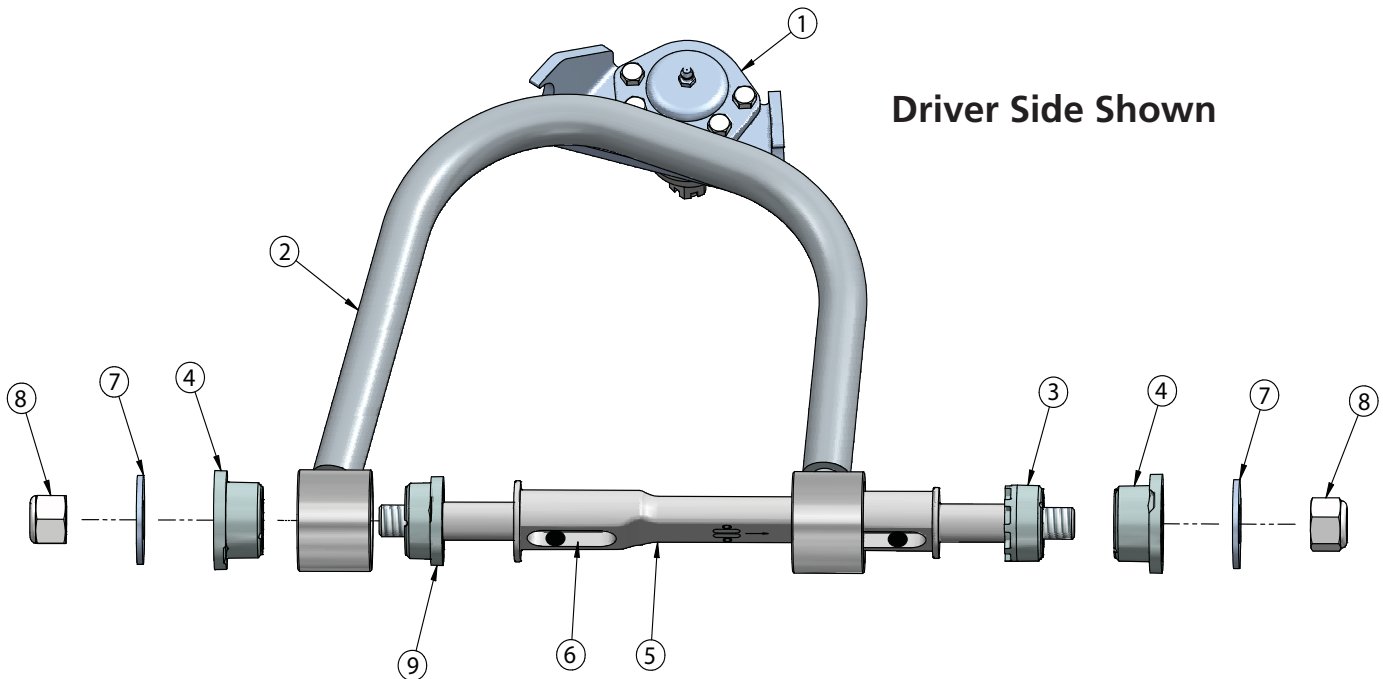



Lower Control Arm ComponentsIn the box

Item #	Part Number	Description	QTY
1	90002159	Driver Lower Control Arm (Shown)	1
1	90002160	Passenger Lower Control Arm	1
2	90002179	Lower Control Arm Cross Shaft	2
3	90000898	Lower Balljoint Assembly	2
4	90000677	Lower Cross Shaft Clamp	2
5	70010827	Delrin Bushing - with 1 3/4" Diameter Ledge	2
6	70010826	Delrin Bushing - no Ledge	2
7	70010759	Delrin Bushing - with 2" Diameter Ledge	2
8	72000257	Outer 1.5" OD Washer	2
9	99622005	5/8"-18 Thin Locknut	4
10	99753005	Flatwasher	4
11	99501024	1/2"-13 x 3 1/4" Hex Bolt	2
12	99502001	1/2"-13 Nylok Nut	2
13	99163001	Outer 2.0" OD Washer	2
	90002062	CoilOver Spacers (not shown)	4

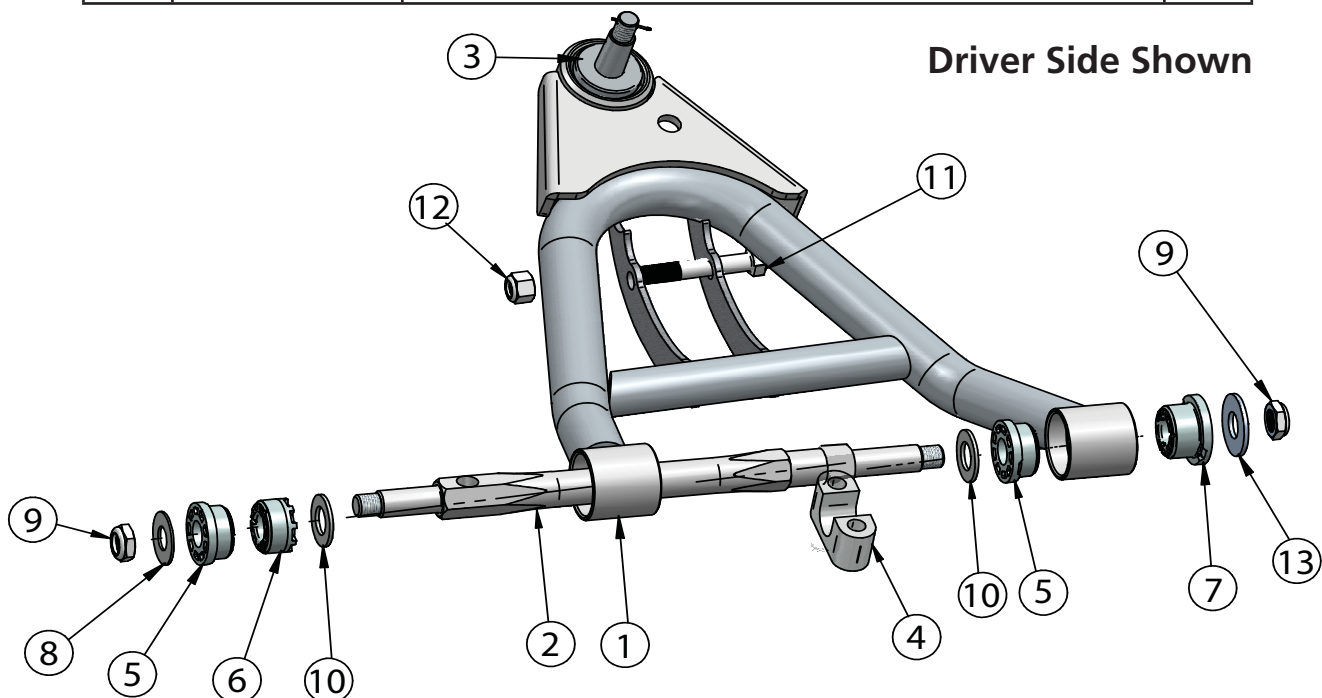



TruTurn Steering ComponentsIn the box

Item #	Part Number	Description	QTY
1	11009300	Ridetech Tall Spindle	1pr.
2	90002173	Driver Steering Arm	1
2	90002174	Passenger Steering Arm (not shown)	1
3	90002170	Draglink Adapter	1
4	90000728	Tie-Rod Adjuster	2
5	90002171	Driver Steering Stop	1
5	90002172	Passenger Steering Stop (not shown)	1
6	70011855	Inner Tie-Rod End	2
7	90009933	Draglink Adapter Stud	2
8	90009931	Outer Tie-Rod Stud	2
9	90001582	Outer Tie-Rod Heim End	2
10	90009932	Tapered Steering Arm Attaching Nut	4
11	99432005	7/16"-20 Castle Nut	4
12	99501008	1/2"-20 x 1 1/2" Hex Bolt	2
13	99502005	1/2"-20 x 2" Hex Bolt	2
14	99501010	1/2"-20 x 2 1/4" Hex Bolt	2
15	99502010	1/2"-20 Mechanical Locking Nut	2
16	99503001	1/2" SAE Flatwasher	4
17	99800002	5/8"-18 Jam Nut	2
18	99800003	5/8"-18 LH Jam Nut	2
19	99622003	5/8"18 Mechanical Locking Nut	2
20	90002373	Tie-Rod Stud Lock Nut Spacer	2

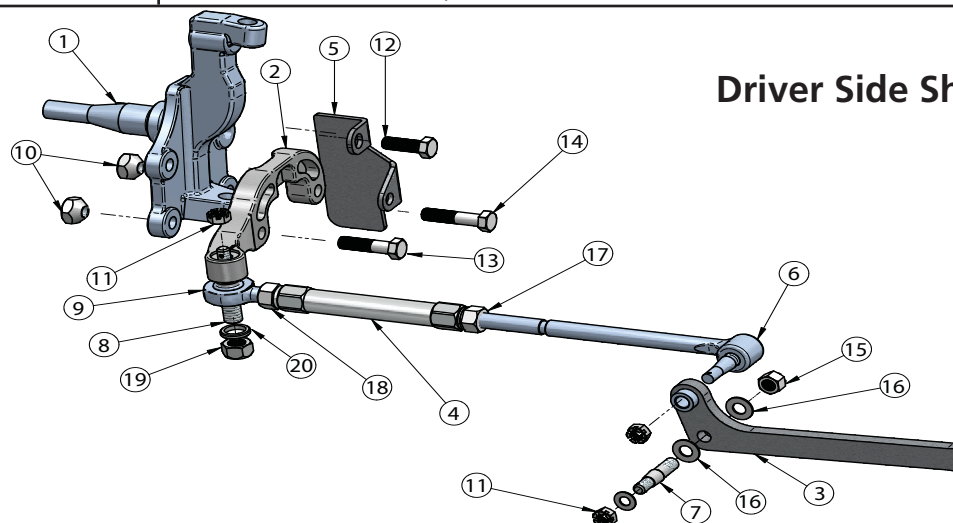

Driver Side Shown



Misc Hardware Not Shown in DiagramsIn the box

QTY	Part Number	Description	
4	99431015	7/16"-20 x 2 1/4" Hex Bolt	Lower Control Arm Clamp to Frame
8	99433001	7/16" Flat Washer	Lower Control Arm Clamp to Frame & Draglink
4	99372001	7/16"-20" Nylok Nut	Lower Control Arm Clamp to Frame
2	99561001	9/16"-18 x 2 1/2" Hex Bolt	Lower Control Arm Cross shaft to Frame
2	99562001	9/16"-18 Nylok Nut	Lower Control Arm Cross shaft to Frame
2	99502003	1/2"-20 Thin Nylok Nut	Steering Stop to Spindle
6	99952002	3/32" Cotter Pin	Tie-Rod and Drag link Adapter Castle Nuts

Getting Started.....

Congratulations on your purchase of the Ridetech TruTurn System. This System have been designed to give your Corvette excellent handling along with a lifetime of enjoyment. Some of the key features of the TruTurn System: Balljoint angles have been optimized for the lowered ride height, Delrin bushings are used to eliminate bushing deflection along with providing free suspension movement through the entire travel. The Geometry has been optimized for excellent handling, driveability and minimal Bumpsteer. The Delrin bushings are made from a material that is self lubricating so no grease zerks are needed. Upper caster adjustable cross shaft is designed to allow you to run maximum caster angles with minimal shims.

Note: These control arms are designed for use with the Ridetech CoilOvers and the MuscleBar swaybar. **The factory shocks and springs or the factory sway bar will not fit these arms.**

Note: The Corvette TruTurn Suspension package uses a GM Spindle used on 67-69 F body, 64-72 A body, and 68-74 X body. Any Brake Kit designed to fit the OEM Disc Brake Spindle of the listed cars will fit the Spindle in your TruTurn System

When assembling the Control Arms tighten the cross shaft nuts enough to create drag on the delrin bushings, the arm should still move through its travel by hand.

Installation

1. Remove the entire front suspension from the car leaving the OEM center draglink. Refer to a Factory Service Manual for the proper method. The Control Arms, Spindles, and Tie rods will all be replaced with the TruTurn package.
2. Drill the factory upper shock mounting hole to 3/4". This can be done easily with a Unibit.



Installing Lower & Upper Control Arm



3. Your new lower control arms utilize a clamp for the front 2 mounting holes. The Clamp will slide into the machined groove in the Cross shaft. Attach the Lower Control Arms to the frame using (1) 9/16" x 2 1/2" Hex Bolt, (1) 9/16" Nylok Nut, (2) 7/16" x 2 1/4" Hex Bolt, and (2) 7/16" Flat washer. Tighten the Cross shaft mounting fasteners. Install the Cross shaft Washers and 5/8" Thin Lock Nuts on the Cross shaft. The Front Crossshaft thread uses (1) 2" OD Flat Washer and (1) 5/8" Thin Lock Nut. The rear Cross shaft thread uses (1) 1 1/2" OD washer and (1) 5/8" Thin Lock Nut. Tighten the cross shaft nuts enough to create drag on the Delrin bushings, the arm should still move up and down by hand.

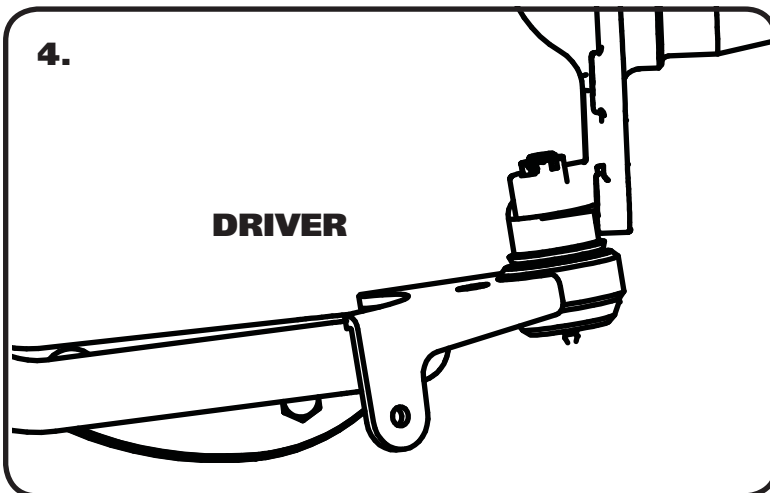

4. The Control Arms are marked "D" for Driver and "P" for Passenger. The Balljoint Pin points up and the Sway bar mount is on the front side of the arm.

Install the CoilOvers at this time. Refer to the CoilOver instructions for Assembly.

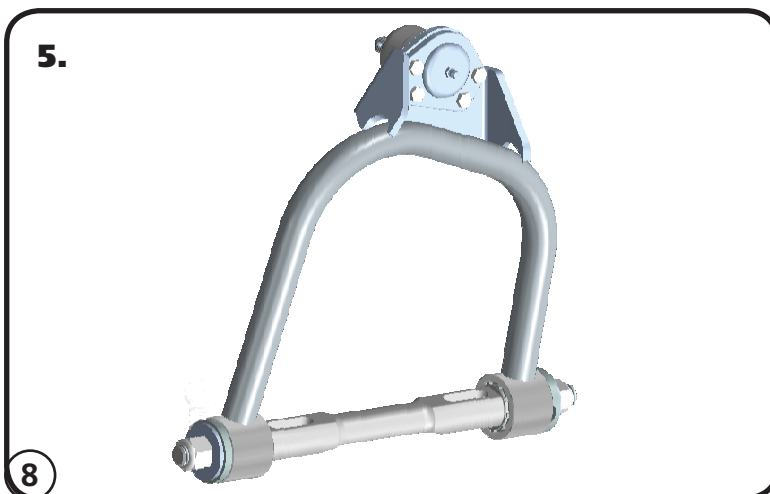

5. Install the balljoints into the upper control arm with the hardware supplied with the balljoint. The upper balljoint goes in from the top side of the control arm. The gussets on the balljoint plate point up. The Upper Control Arm is attaching the factory mount using factory hardware. The driver side arm is shown in Figure "5". The Arrow on the Cross shaft points to the front of the car. Page 8 & 9 has information about Caster and the Caster Slugs.



Caster Explained

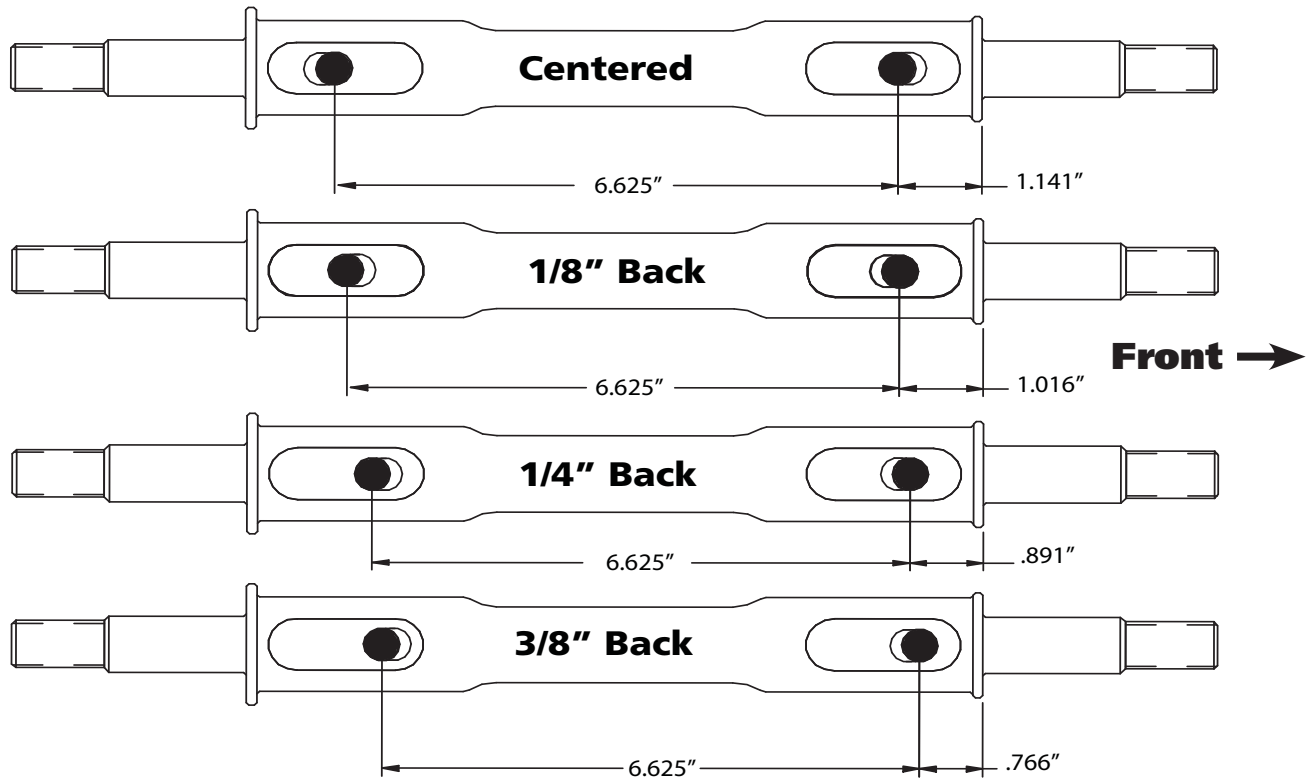

These StrongArms come equipped with a changeable caster slug setup. This allows you to add or remove caster from the front suspension, if desired. The caster slugs that come supplied in the kit are setup to be centered or 1/8" back. The caster slugs allow you to add or remove caster without having to use a stack of shims. If more or less caster is desired, optional slugs can be purchased from Ridetech or your Ridetech dealer.

Caster Explained:

To understand caster you need to picture an imaginary line that runs through the upper balljoint and extends through the lower balljoint. From the side view the imaginary line will tilt forward or backward. The tilting of this imaginary line is defined as caster.

Caster is measured in degrees by using a caster gauge. If the imaginary line described above tilts towards the back of the vehicle at the top, then you have positive caster. If the imaginary line tilts forward then you have negative caster.

Positive caster provides the directional stability in your vehicle. Too much positive caster will make the steering effort difficult. Power steering will allow you to run more positive caster. Negative caster requires less steering effort but will cause the vehicle to wander down the highway



Offset Upper Control Arm Shaft

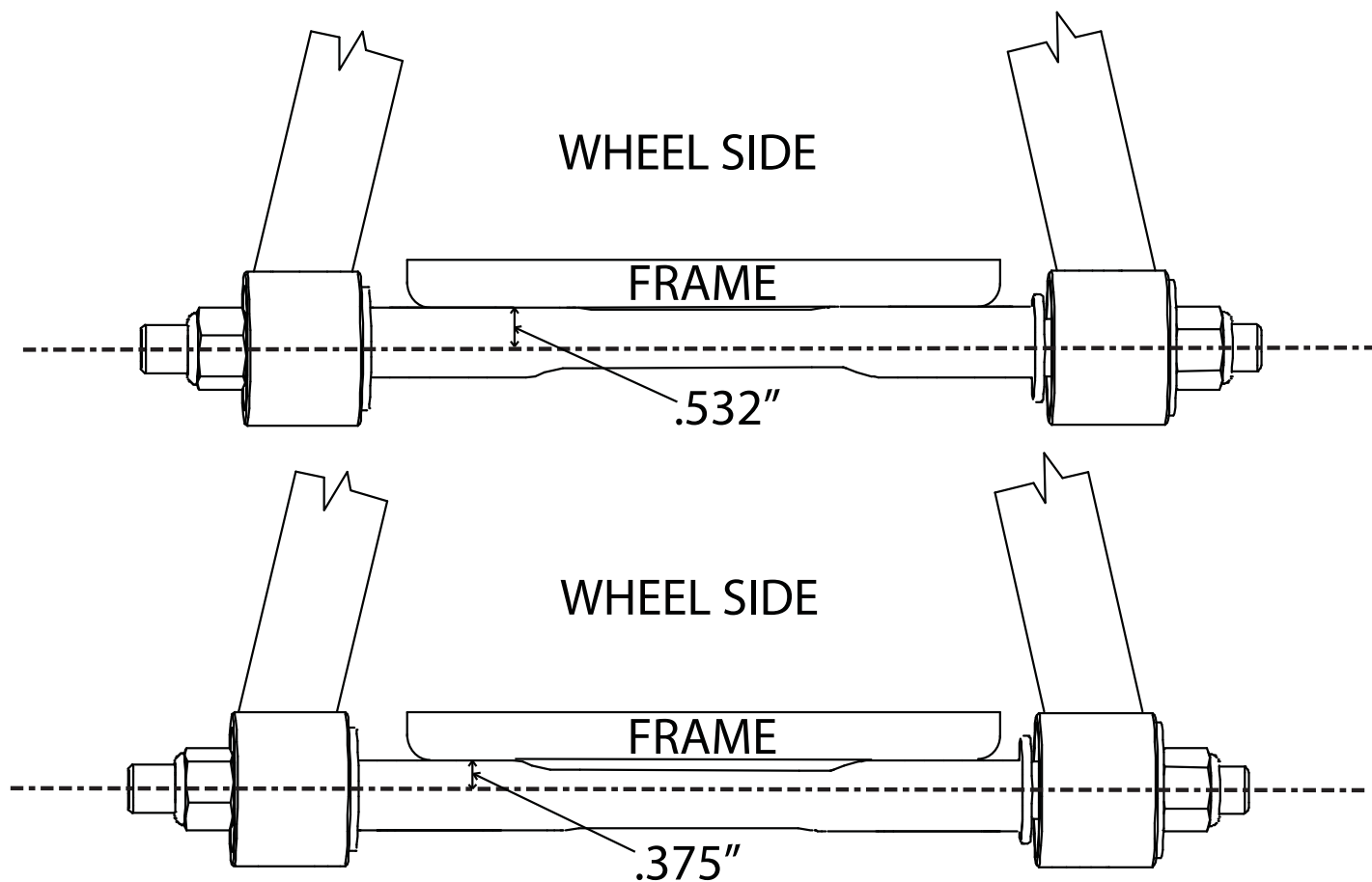

The cross shaft that is used in the upper control arms is offset. The offset combined with the caster slug option allows you to achieve the alignment setting you desire with minimal shims. To change the direction the Icon faces simply spin the cross shaft in the control arm.

If you are after a **Street Alignment** bolt the upper control arm to the frame mount with the arm offset to the outside of the car. The Ridetech Icon and Caster Slugs will be facing the wheel.

If a more aggressive **Track or Autocross** alignment is desired, bolt the control arm to the frame bracket with the arm offset to the inside of the car. The Ridetech Icon and Caster Slugs will be facing the engine.



Installing Upper Control Arm and Spindle

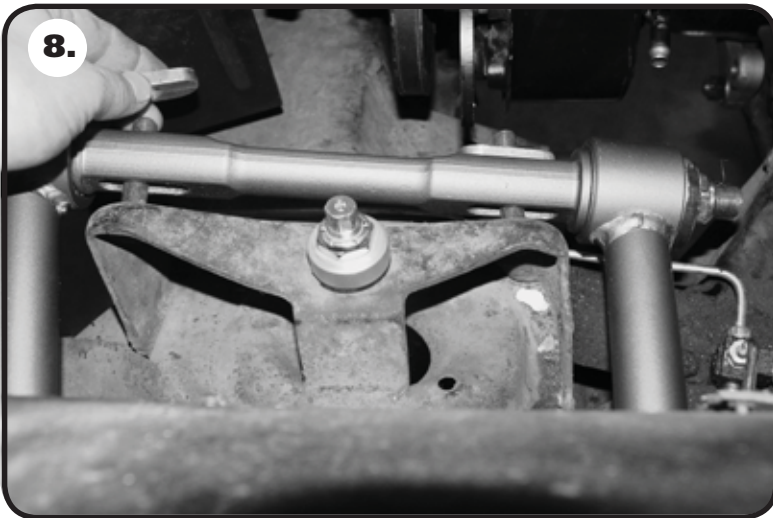

8. Bolt the upper Control arm to the car using the previous pages to assist you with Cross Shaft orientation and Caster Slug Location. Install (2) 2" OD washers and (2) 5/8" Thin Lock Nuts on each Crossshaft. Tighten the crossshaft nuts enough to create drag on the delrin bushings, the arm should still move up and down by hand.

Note: The kit comes standard with centered Caster Slugs.

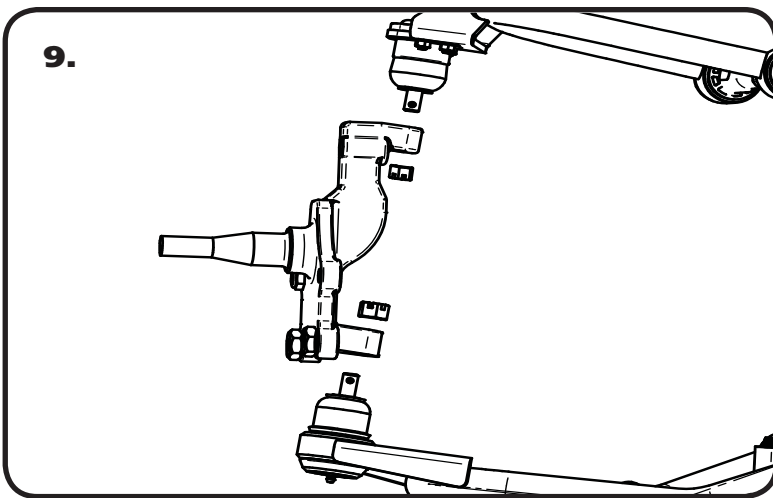

9. Attach the Spindle to the control arms. The Spindle is the same for Driver and Passenger.

Torque Specs:

Lower Balljoint - 65 ftlbs and tighten to line up cotter pin.

Upper Balljoint - 50 ftlbs and tighten to line up cotter pin.

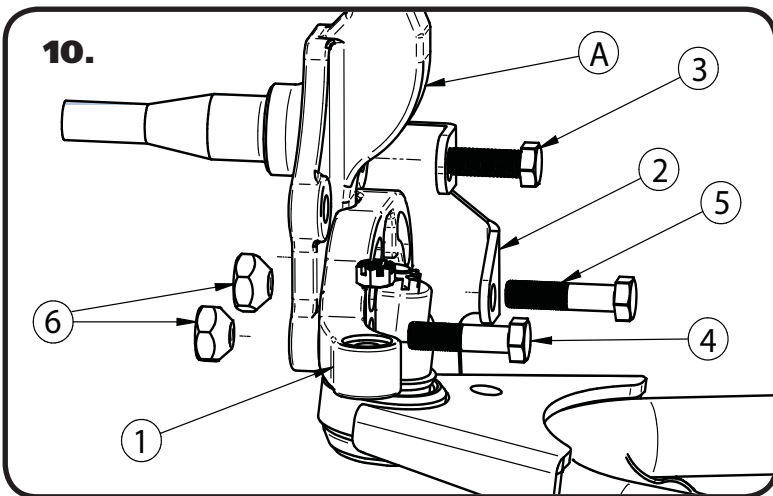

10. Attach Steering Arm(1) and Steering Stop(2) to Spindle(A). 1/2"x 1 1/4"(3), 1/2" x 2"(4), 1/2"x 2 1/2"(5) Hex Bolts, 1/2" Thin Nylok(Used on 3), & Tapered Nuts(6) are used to attach them. The Steering Arm is positioned with the Tie Rod End pointing to the rear of the car and toward the engine. The Steering stops are marked "D" & "P". Use Red Loctite (Supplied in the Kit) on the Bolts for the Tapered Nuts and Torque to 75 ftlbs.



Installing TruTurn System

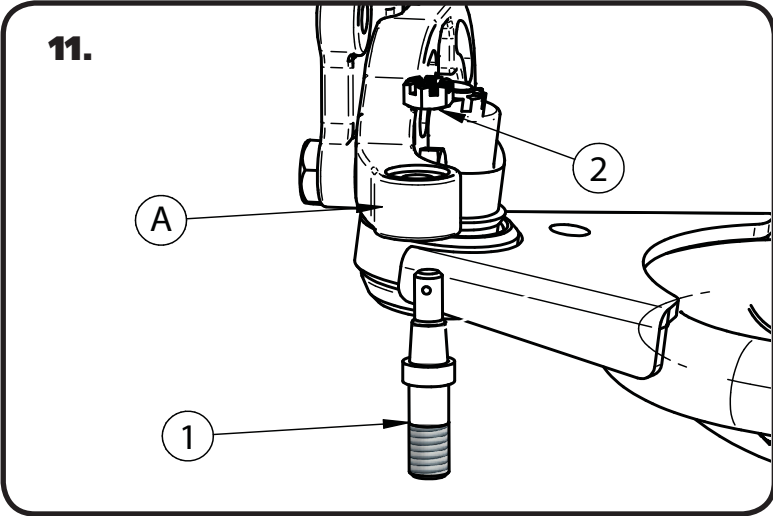

11. Install Outer Tie rod Stud into Steering arm using a 7/16" Castle Nut and 3/32" Cotter Pin. Insert the Tapered end of the Tie Rod Stud into the Taper of the arm. Thread the 7/16" Castle nut on the stud. Torque to 35 ftlbs and then tighten to align Cotter Pin hole with slot on Castle Nut. Install Cotter Pin.

Note: The Outer Tie Rod Stud is the LARGER of the tapered studs in the kit.

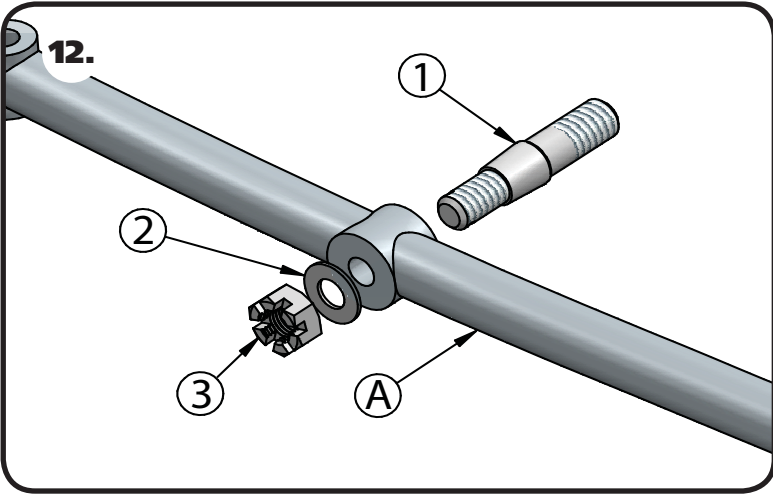

12. Install a Tapered Draglink Stud (1) into the OEM Inner Tie-Rod Hole on the OEM Draglink (A). Install a 7/16" Flatwasher(2) onto the threads. Thread a 7/16" Castle Nut (3) onto the threads to hold it in place. **Do Not Tighten Nut Yet.** It will be tighten after the Draglink Adapter is installed on the Studs. Install Driver and Passenger Studs.

Note: Due to variances in thickness of the OEM Draglink, it may be necessary to install another 7/16" Flatwasher under the Castle Nut to engage to Cotter Pin into the Castle Nut properly.

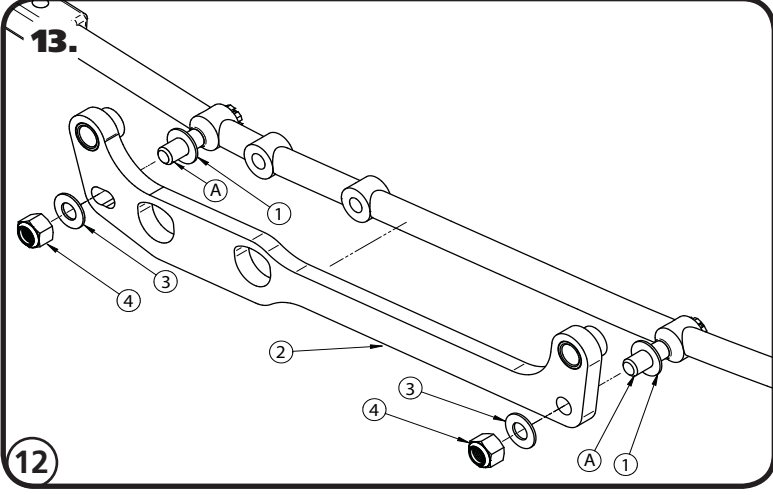

13. Slide a 1/2" Washer(1) onto the Draglink Studs(A). Next, slide the Draglink Adapter(2) onto the Studs(A). The Adapter is positioned with the 2 clearance holes to the Passenger side and the Inner Tie-Rod Mounting holes upward. Tighten the "2" 7/16" Castle Nuts to 35 ftlbs and then tighten to align the cotter pin hole. Install Cotter pin. Install the 1/2" Flatwasher(3) and 1/2" Mechanical Locking Nuts(4) onto the Studs and Torque to 50 ftlbs.



Tie-Rod Assembly and Installation

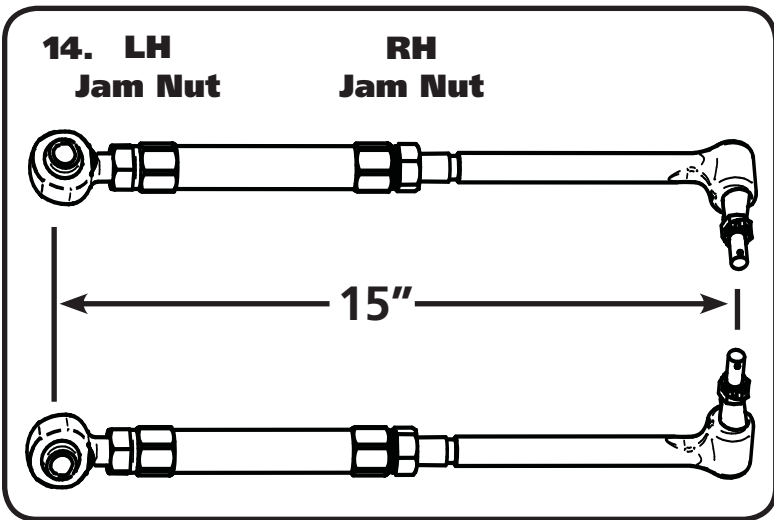

14. Assemble the Tie-Rod to a center to center length of 15" to start with, having equal amount of thread engagement on both ends. These Aluminum adjusters have a left hand thread on one end and a right hand thread on the other. Use anti-seize on the threads of the Tie Rod and Heim end before threading them into the adjuster.

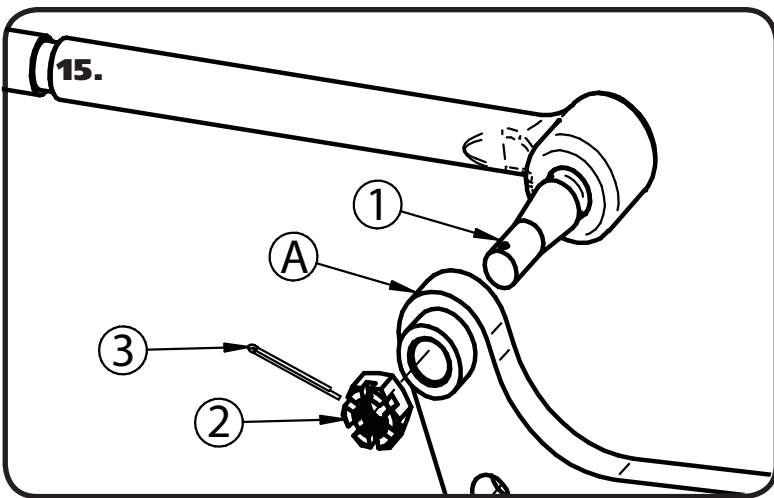

15. Insert the Inner Tie-Rod End(1) into the Draglink Adapter(A). Install the Castle Nut(2) supplied with the Tie-Rod End onto the threads. Torque Castle Nut to 35 ftlbs and tighten to align Cotter Pin hole. Install Cotter Pin(3).

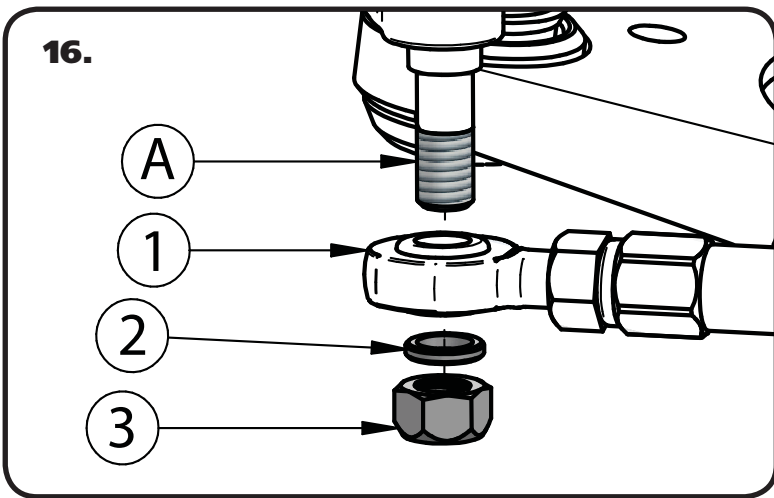

16. Slide the Heim End(1) onto the Tie-Rod Stud(A). Next, slide the Nut Spacer(2) onto the Stud. Thread the 5/8"-18 Mechanical Locking Nut(3) onto the Tie-Rod Stud. Torque nut to 100 ftlbs.



The Finish

15. Tighten all fasteners. If you are going to install the Ridetech MuscleBar, now is a good time to do it.

When assembling the Control Arms tighten the cross shaft nuts enough to create drag on the delrin bushings, the arm should still move through its travel by hand.

Suggested Alignment Specs:

Camber: Street: -.5 degrees
Caster: Street: +3.0 to + 5.0 degrees
Toe: Street: 1/16" to 1/8" toe in

STILL HAVE QUESTIONS?

Tech line hours

Monday - Friday

8AM - 6PM (EST) 812-482-2932



Part # 11533511 - 1968-1982 C3 TQ Front CoilOvers

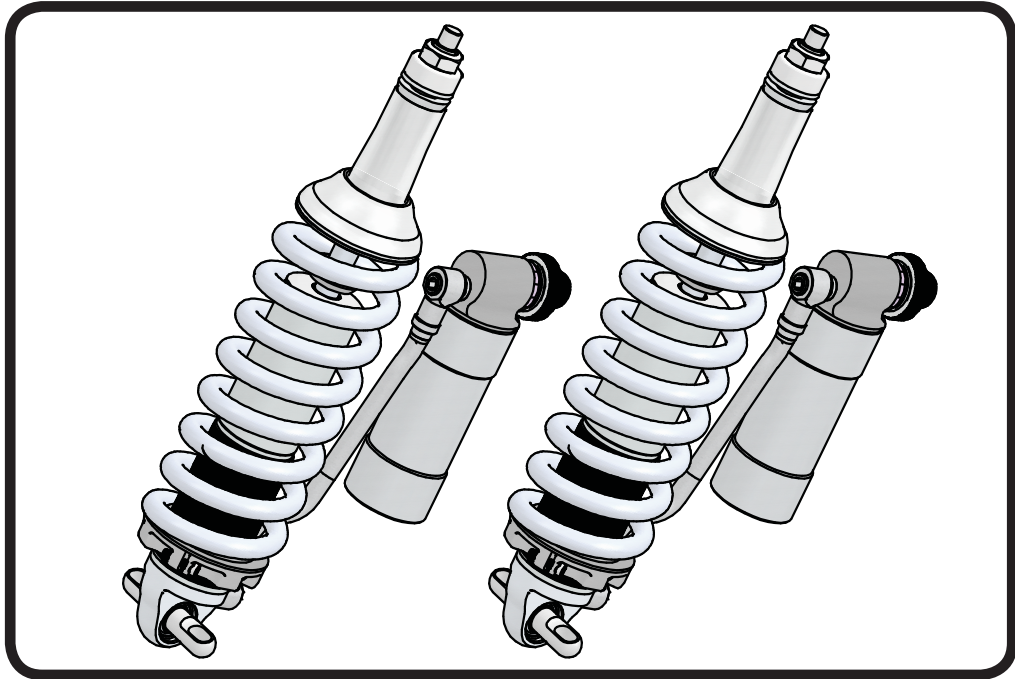

Recommended Tools

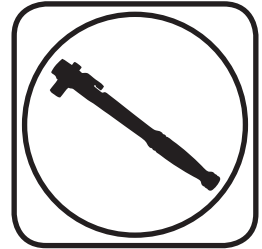

1968-1982 C3 TQ Series Front CoilOvers Installation Instructions

Table of contents

- Page 16..... Included components
- Page 17..... CoilOver Assembly
- Page 18..... CoilOver Installation
- Page 19..... CoilSpring Adjusting



Major ComponentsIn the box

Item #	Part #	Description	QTY
1	24349999	4.1" Stroke TQ Series Shock	2
2	59100575	Coilspring 10" 575lb	2
3	70010828	Delrin Spring Washer	4
4	90002222(kit)	Lower Spring Adjuster Nut (90002222 kit)	2
5	90002222(kit)	Adjuster Nut Locking Screw (90002222 kit)	2
6	90002222(kit)	Upper CoilSpring Retaining Plate	2
7	90002222(kit)	CoilSpring Plate Retaining Ring	2
8	90009983(kit)	3.75" Stud Adjuster Assembly	2
9	90002314	3.75" Stud Top Base	2
10	90001904	Delrin Ball Lower Half	2
11	90001903	Delrin Ball Top Half	2
12	90001902	Delrin Ball Upper Cap	2
13	99562003	9/16-18" Nylok Nut	2
14	90009983(kit)	Shock Adjuster Knob	2
15	90009983(kit)	Adjuster Knob Retaining Screw	2
	90002221	Reservoir Mounts	4
	90005000	Resercoir Mount Socket Head Cap Screw	12
	90001994	5/8" ID Bearing (installed in shock body)	2
	90001995	Bearing Snap Ring (installed in shock body)	4
	85000003	Hex Wrench for Reservoir Mounting Screws	1

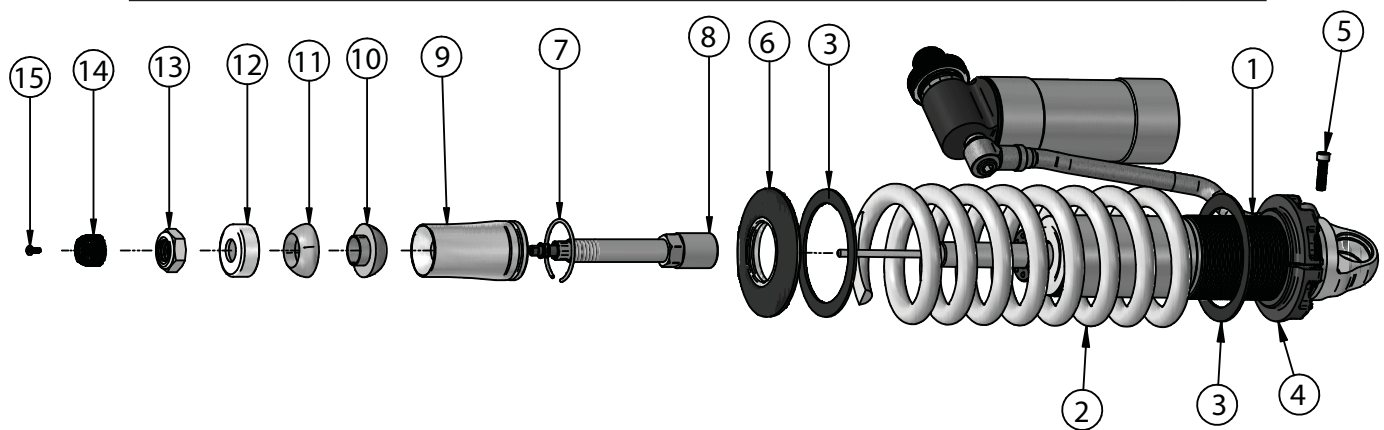



CoilOver Assembly

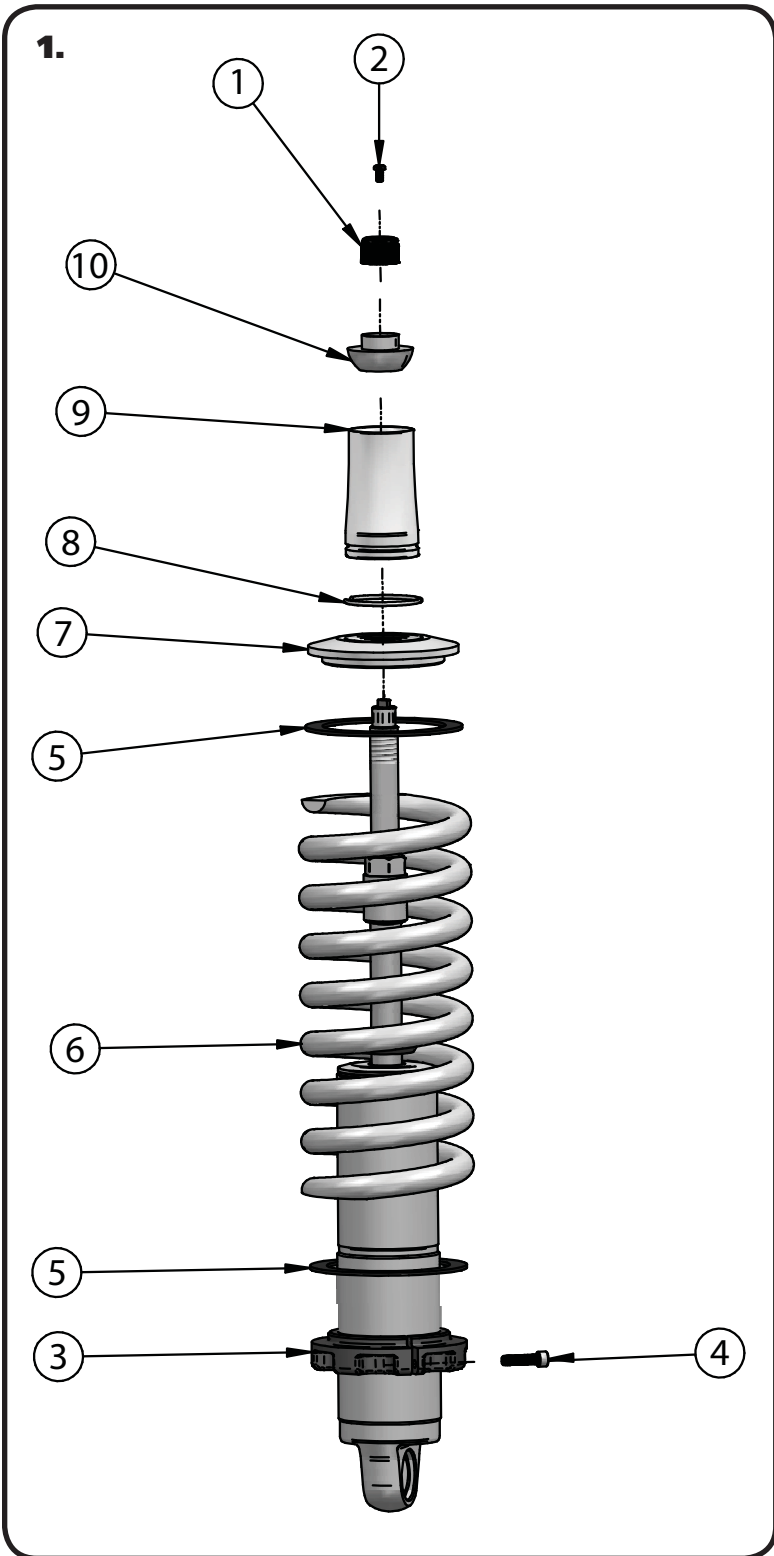

1. To Assemble the CoilOver you need to:
 - a. Remove Screw (2) from center of Adjustment Knob (1) and remove Adjustment Knob.
 - b. Remove Nylok Nut, Delrin Upper Cap, Delrin Upper and Lower Balls, along with the base from the Coliover stud.
 - c. Thread Adjuster Nut (3) onto the CoilOver body. Once it is threaded on the shock body, lightly thread in the locking screw (4) into the Adjuster Nut.
 - d. Install a Delrin Spring Washer (5) onto the Adjuster Nut.
 - e. Slide the CoilSpring (6) onto the CoilOver.
 - f. Install another Delrin Spring Washer (5) on top of the CoilSpring.
 - g. Install the Upper CoilSpring Plate (7) onto the CoilSpring.
 - h. Install the CoilSpring Retaining Ring (8) onto the Stud Top Base (9). It fits into the groove in the base.
 - i. Slide the Stud Top Base onto the shock until it bottoms out on the stud. It may be necessary to thread the Adjuster Nut down the shock body (to lower the spring) if the base will not slide all the way down onto the stud.
 - k. Slide the Lower Delrin Ball (10) (it has the collar sticking up around the center hole) on to the Stud Top.

Repeat on second CoilOver.



CoilOver Installation

2.

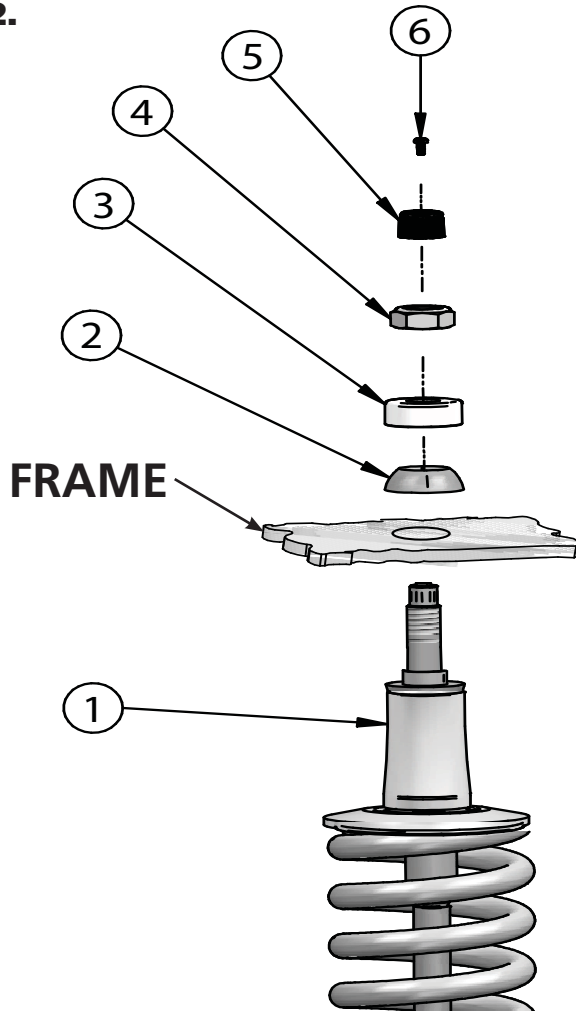

2. With the CoilOver(1) assembled, it is time to bolt them into the car. **The factory shock hole will need to be drilled out to 3/4", this can best be done using a Unibit.** Insert to CoilOver Stud Top through the factory hole in the frame. Install the Upper Delrin Ball(2) onto the shock stud with the flat side facing the frame. Next, Install the Delrin Ball cap (3) onto the shock stud with the Concave side facing the Upper Delrin ball. Install the Nylok Nut(4) onto the shock stud and lightly tighten. There needs to be some resistance on the ball but not tight enough that it will not rotate freely. Reinstall the adjuster knob(5) using the screw (6) that was removed during step 1.

3.

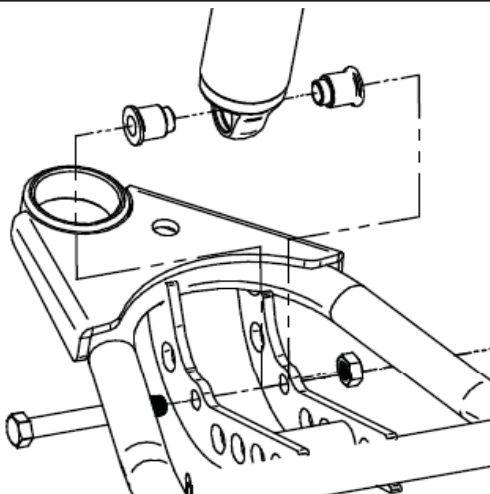

3. Install a spacer on each side of the lower Coilover. Slide the shock with the spacers installed into the lower control arm. Raise the arm up to line up the holes in the bushing with the 1/2" hole in the control arm straps and hold it in place while you install the 1/2" x 3 1/4" bolt and 1/2" Nylok nut. Tighten the upper and lower shock bolts.



CoilSpring Adjusting

Ride Height

We have designed most cars to have a ride height of about 1 1/2" lower than factory. To achieve the best ride quality & handling, the shock absorber needs to be at 40-60% overall travel when the car is at ride height. This will ensure that the shock will not bottom out or top out over even the largest bumps. Measuring the shock can be difficult, especially on some front suspensions. Measuring overall wheel travel is just as effective and can be much easier. Most cars will have 4-6" of overall wheel travel. One easy way to determine where you are at in wheel travel is to take a measurement from the fender lip (center of the wheel) to the ground. Then lift the car by the frame until the wheel is just touching the ground, re-measure. This will indicate how far you are from full extension of the shock. A minimum of 1.5" of extension travel (at the wheel) is needed to ensure that the shock does not top out. If you are more than 3" from full extension of the shock then you are in danger of bottoming out the shock absorber.

Adjusting Spring Height

When assembling the CoilOver, screw the spring retainer tight up to the spring (0 preload). After entire weight of car is on the wheels, jounce the suspension and roll the car forward and backward to alleviate suspension bind.

- If the car is too high w/ 0 preload then a smaller rate spring is required. Although threading the spring retainer down would lower the car, this could allow the spring to fall out of its seat when lifting the car by the frame.
- If the car is too low w/ 0 preload, then preload can then be added by threading the spring retainer up to achieve ride height. On 2.6" - 4" stroke shocks, up to 1.5" of preload is acceptable. On 5-7" stroke shocks, up to 2.5" of preload is acceptable. If more preload is needed to achieve ride height a stiffer spring rate is required. Too much preload may lead to coil bind, causing ride quality to suffer.



Part # 11539100 - 1968-1982 C3 Front MuscleBar

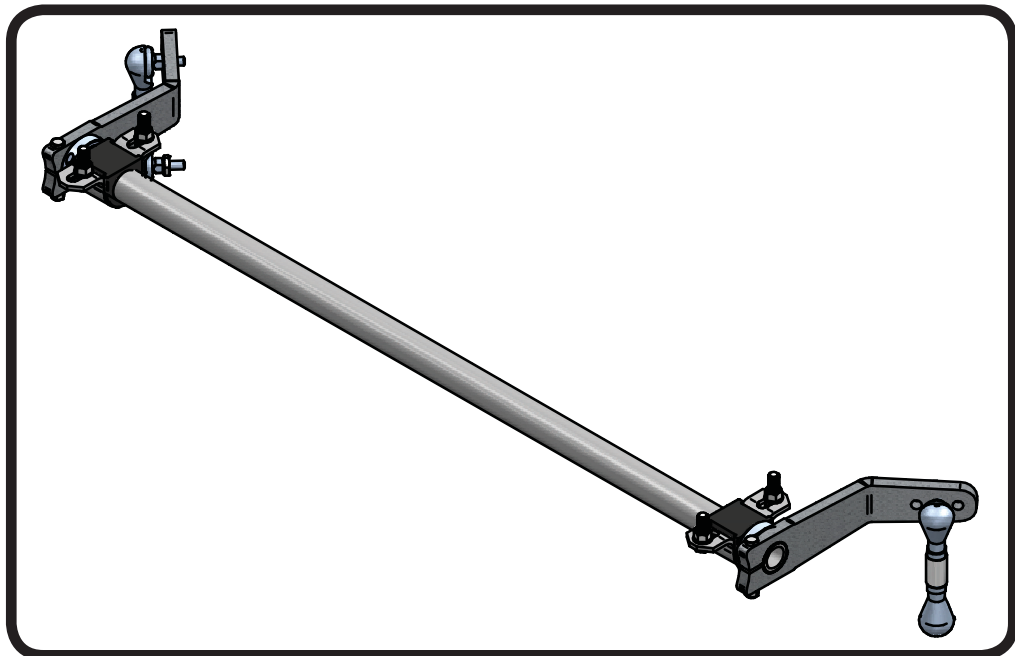

Recommended Tools

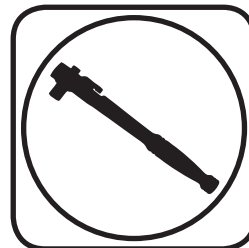

1968-1982 C3 Front MuscleBar Installation Instructions

Table of contents

- Page 21..... Included components and Hardware List
- Page 22..... Getting Started
- Page 23..... MuscleBar Installation
- Page 24..... MuscleBar Installation
- Page 25..... Final Assembly



Major ComponentsIn the box

Item #	Part #	Description	QTY
1	70011923	1.250" Splined MuscleBar	1
2	90002180	Spline MuscleBar Arm - Driver	1
2	90002193	Spline MuscleBar Arm - Passenger	1
3	90001100	Poly Bushing and Frame Bracket	2
4	70011928	Locking Ring	2
5	90000926	10mm 90 degree elbow (Preassembled Posilink)	4
6	90002342	Posilink Spacer (Preassembled Posilink)	2
7	99115008	M10-1.5 75mm stud (Preassembled Posilink)	2
8	90002177	MuscleBar Frame Bushing Spacer (C3 Only)	4
	90001092	Tube of Lithium Grease (Not Shown)	1

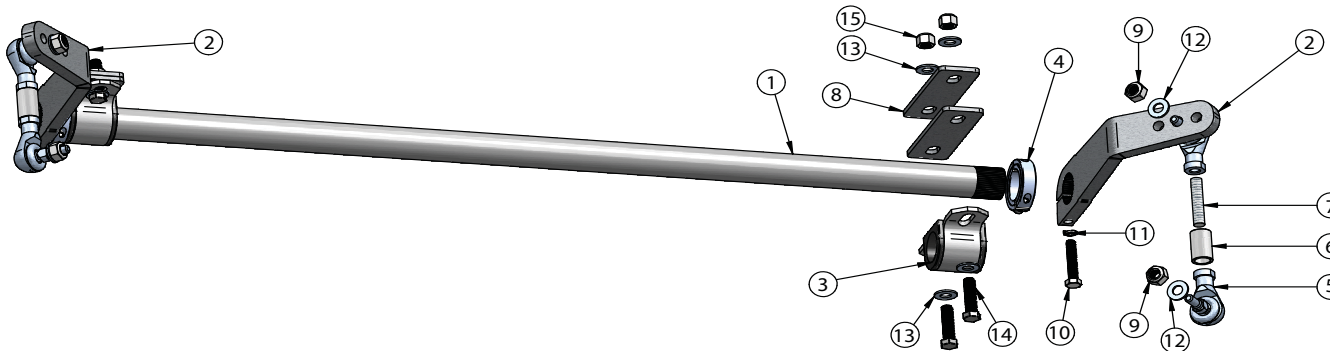

Hardware ListIn the box

Item #	QTY	Part Number	Description	Location
9	4	99112002	M10-1.5 Nylok Nut	Posilink to Swaybar and StrongArm
10	2	99311022	5/16"-18 x 1 3/4" Hex Bolt	MuscleBar Arm Pinch Bolt
11	6	99313003	5/16" Split Lockwasher	MuscleBar Arm Pinch Bolt, Bushing to Frame (C3)
12	8	99373003	3/8" SAE Flatwasher	Posilink
13	8	99373003	3/8" SAE Flatwasher	MuscleBar Bushing to Frame (C2 Only)
13	4	99313002	5/16" SAE Flatwasher	MuscleBar Bushing to Frame (C3 Only)
14	4	99371004	3/8"-16 x 1 1/4" Hex Bolt	MuscleBar Bushing to Frame (C2 Only)
14	4	99311003	5/16"-18 x 1 1/2" Hex Bolt	MuscleBar Bushing to Frame (C3 Only)
15	4	99372002	3/8"-16 Nylok Nut	MuscleBar Bushing to Frame (C2 Only)



Getting Started.....

Congratulations on your purchase of the Ridetech Front MuscleBar. This kit has been designed to give your Corvette excellent handling along with a lifetime of enjoyment. Some of the key features of this MuscleBar: Posilinks - The Posilink makes the reaction of the swaybar instantaneous, tunability - this Musclebar has 3 positions to aid in the tuning of the handling of your Corvette.

Note: This MuscleBar is designed to be used with the Ridetech StrongArms.

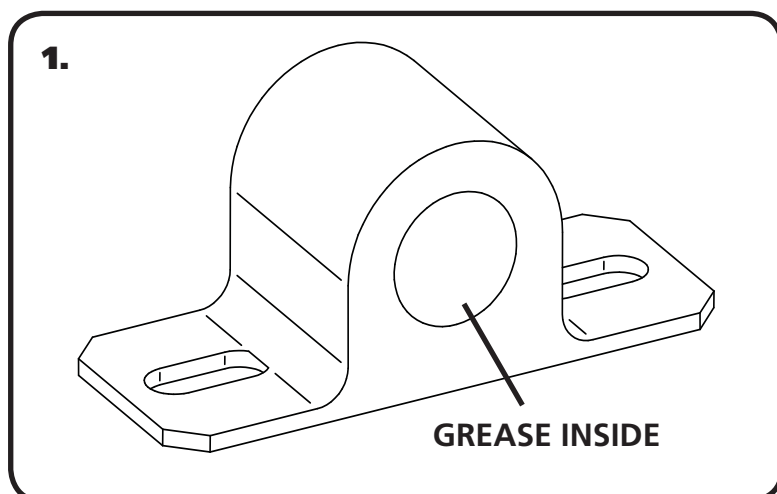

1. Apply Lithium grease to the inside of the sway bar bushings using the tube of grease supplied in the kit.

STEPS 2 - 4 ARE FOR C2 CORVETTE ONLY, IF INSTALLING ON C3 SKIP TO STEP 5

C2 Frame Bushing Mounting

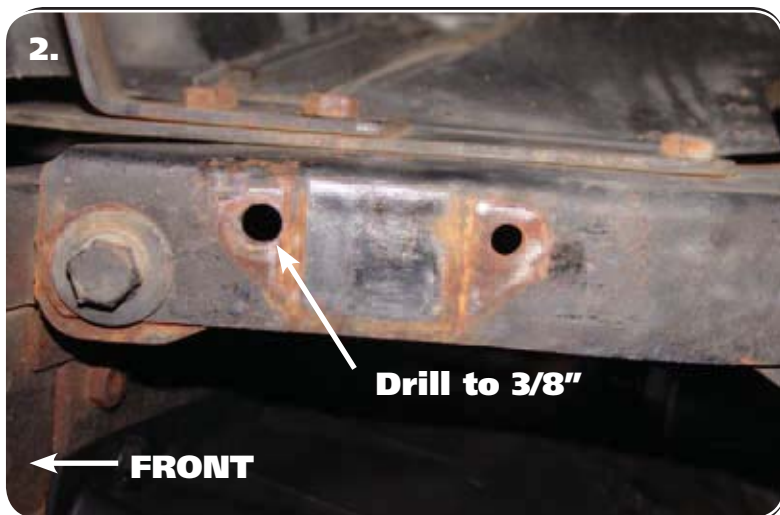

2. Drill Out the forward ORIGINAL swaybar mounting hole to 3/8". The original rear hole will not be used. A new mounting hole for the rear bolt will be drilled in Step #4.



C2 MuscleBar Installation



3. Insert the MuscleBar into position by sliding it between the bumper support and the frame rail. With the MuscleBar slid in place, install the mount bushing onto each end of the MuscleBar followed by the mounting strap.

NOTE: Approximately 1 3/8" of the bar end will be sticking out of the bushings.



4. Insert a 3/8" -16 x 1 1/4" Bolt and Flatwasher through the front mounting strap hole and hole that was drilled out in step #3. Install a 3/8" Flatwasher and Nylok Nut on the bolt and lightly tighten making sure the bolt stays in the center of the slot. With the bolt and nut lightly tighten clamp the loose end of the strap to the frame. With the strap clamped in place, drill a 3/8" hole in the center of the slot in the mounting strap. Repeat on other side. Install 3/8" x 1 1/4" Bolt, flatwashers, and Nylok Nut in drilled hole. **DO NOT TIGHTEN.**

AFTER COMPLETION SKIP TO STEP 7

C2 MuscleBar Installation

STEPS 5 - 6 ARE FOR C3 CORVETTE ONLY.



C2 MuscleBar Installation

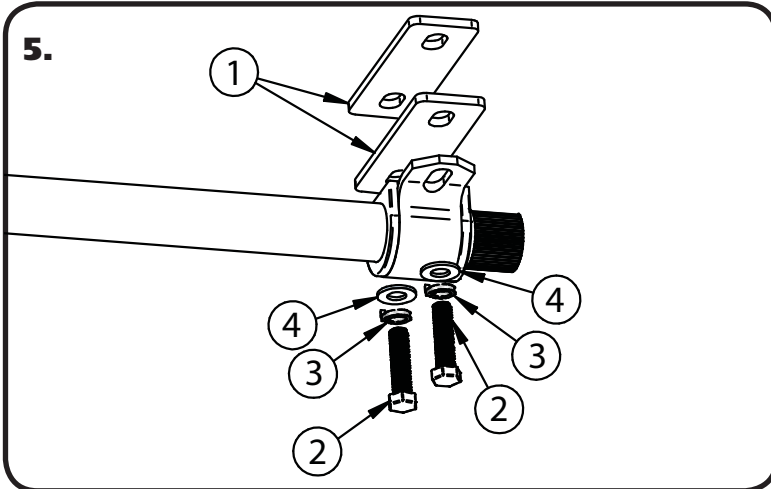

5. The Musclebar on the C3 is bolted into the OEM swaybar position. The C3 uses Spacers(1) to position the bar correctly on the chassis. These spacers are installed in between the Bushing Assembly and the frame. Insert a 5/16" x 1 1/2" Bolt(2), 9/16" Lockwasher(3), and 5/16" Flatwasher(4) through each slot in the Bushing Mount. Install the 2 Spacers(1) on the bolt before threading it into the factory swaybar mounting hole in the frame. **DO NOT TIGHTEN.**

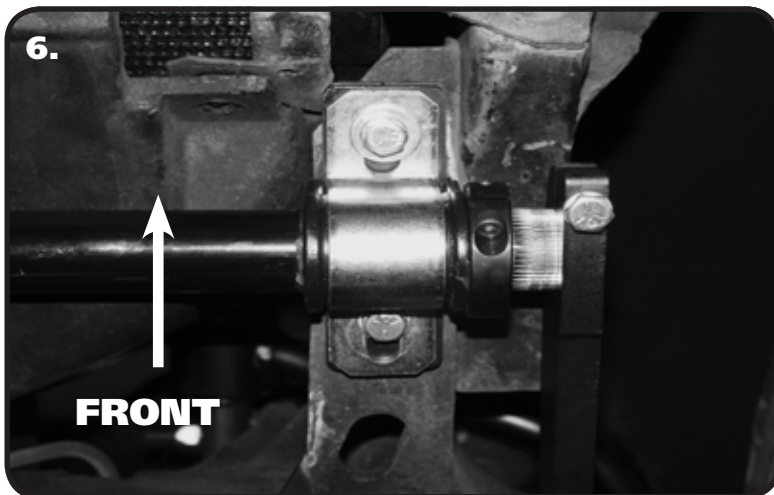

6. The MuscleBar will be slid to the rear of the car when doing final tightening of the Bushing Mounts.

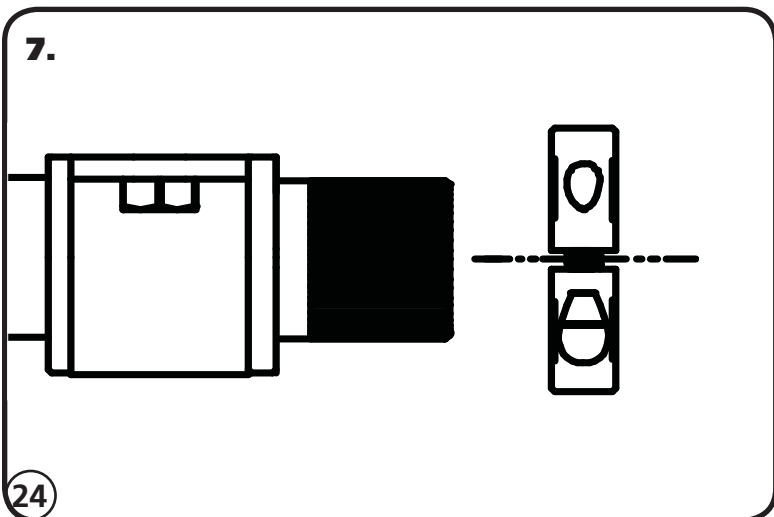

7. Install locking ring onto MuscleBar. **DO NOT TIGHTEN.**



MuscleBar Installation

8.

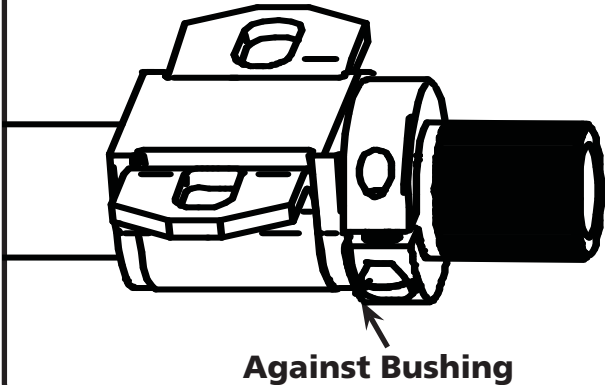

Against Bushing

9.

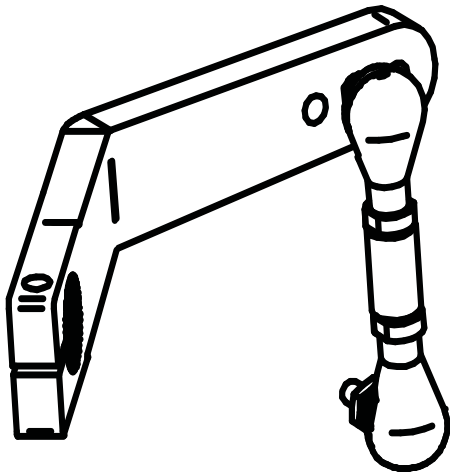

10.

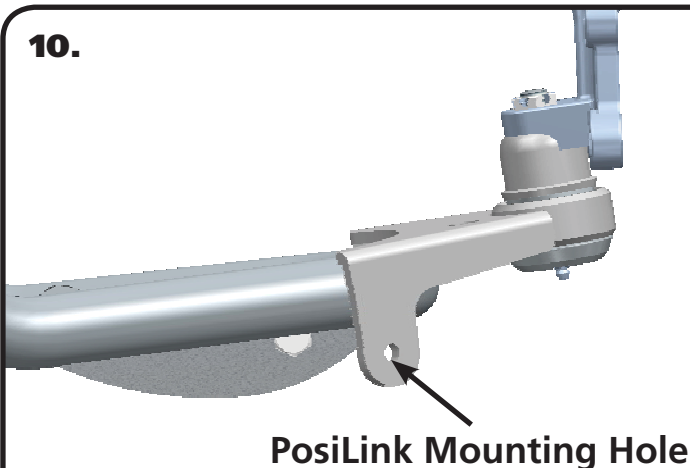

PosiLink Mounting Hole

8. With all 4 bolts installed, center the MuscleBar in the bushings. There should be approximately (1 3/8" C2) (1 9/16" C3) sticking out of the bushing on each side. With the MuscleBar center, slide the locking rings up against the bushings and tighten them down. Tighten the Bushings Mounting hardware.

9. Install the Posilink into the center hole on the MuscleBar arm using Diagram #7 as a reference. Tighten using a 3/8" Flatwasher on each side of the arm and a 10mm Nylok nut.

NOTE: Driver and Passenger are installed in the same orientation. For the Passenger side, you will simply spin the Posilink over 180 degrees. There is a Driver and Passenger Arm, the arms are installed with the Pinch Bolt installing from the bottom of the arm.

10. **This step needs to be done with the complete front suspension installed on the car.** It is critical to get the arms clocked on the MuscleBar the same, we found a simple way to do it. With the StrongArms hanging at full extension, slide the MuscleBar arms onto the bar. Try to insert the loose end of the Posilink into the mounting hole on the StrongArm. If it will not slide into the hole, remove the Swaybar arm from the bar and reposition it until the Posilink will slide into the mounting hole with little effort. Repeat the procedure on the other side. The arms are now clocked the same.



Final Installation

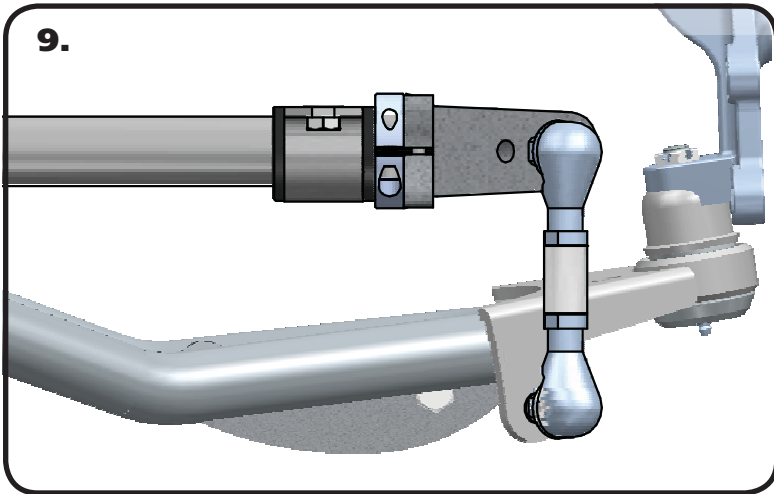

11. With the arms installed on the MuscleBar, install a 3/8" Flatwasher on each side of the tab along with a 10mm Nylok Nut onto the Posilink and Tighten.

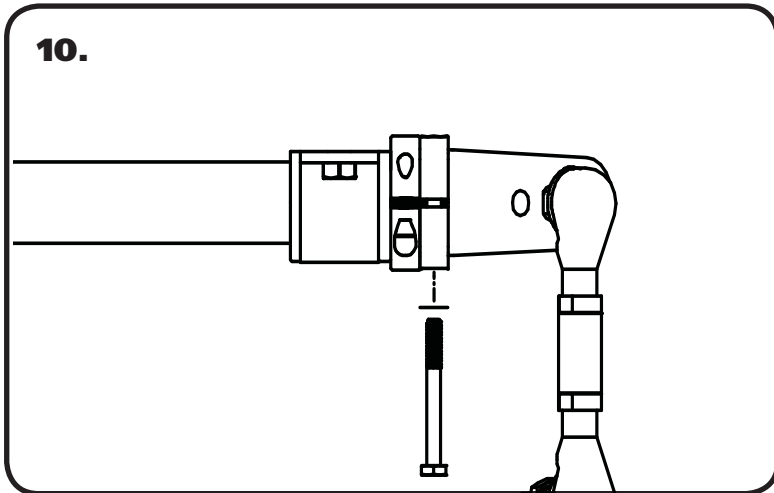

12. Position the Arm so that it is even with the ends of the splines. Install 5/16"x 1 3/4" bolt, along with a 5/16" Lockwasher in from the bottom of the MuscleBar arm. Torque the bolt to 25 ftlbs.

13. Double check all hardware to make sure its tight.

The MuscleBar has 3 positions to aid in the tuning of your Corvette's handling. We start in the center position and tune from there. The Position to the front of the car shortens the arm and will make the Musclebar stiffer. The position to the rear of the car lengthens the arm and will make the MuscleBar softer.

Note: If any grease is needed after installation use a lithium based grease. **DO NOT USE A PETROLEUM BASED GREASE**

STILL HAVE QUESTIONS?

Tech line hours
Monday - Friday
8AM - 6PM (EST) 812-482-2932

www.ridetech.com
812-482-2932



Part # 11537199 - 1968-1979 C3 Rear StrongArms

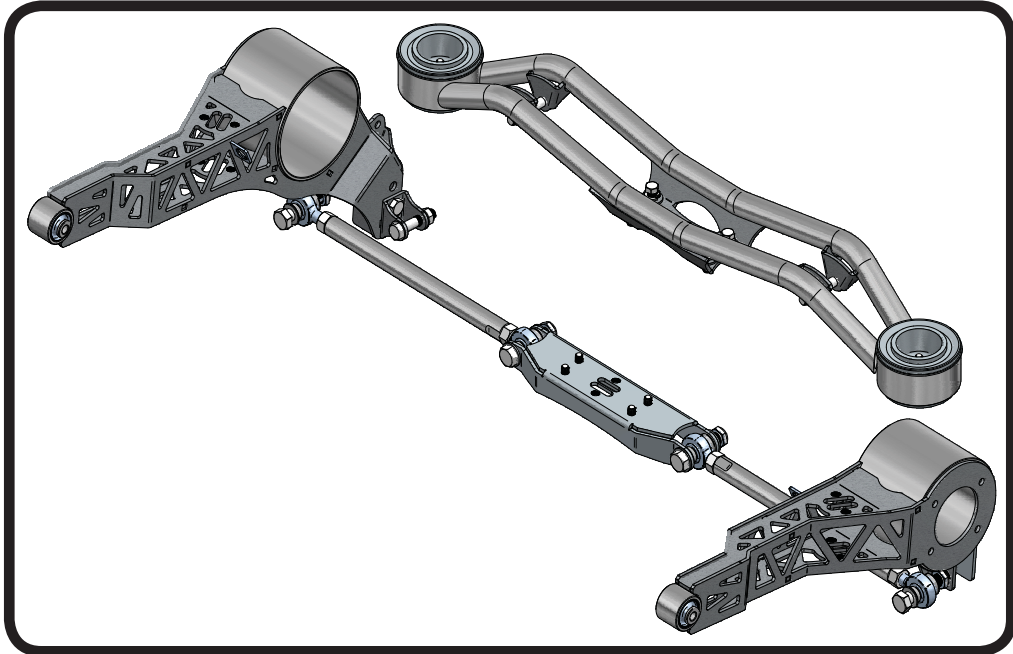

Recommended Tools

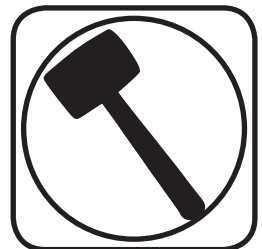
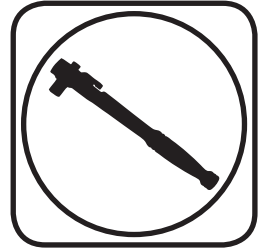

1968-1979 C3 Rear StrongArms Installation Instructions

Table of contents

Page 21..... Included components
Page 22..... Hardware List and Getting Started
Page 23..... Disassembly and Upper Crossmember Installation
Page 24..... Strut Rod Bracket and Trailing Arm Installation
Page 25..... Trailing Arm & Strut Rod Installation
Page 26..... Shock Mount & CoilOver Installation
Page 27..... Finishing



Major ComponentsIn the box

Item #	Part #	Description	QTY
1	90002163	Driver Trailing Arm	1
2	90002164	Passenger Trailing Arm	1
3	90002165	Upper Crossmember	1
4	90002166	Strut Rod Mount	1
5	90002158	CoilOver Lower Mounting Bracket	2
6	90002167	Threaded Strut Rod	2
7	90001590	Strut Rod Heim End 5/8'-18 RH Thread (Pre installed in Strut Rod)	2
8	90001582	Strut Rod Heim End 5/8'-18 LH Thread (Pre installed in Strut Rod)	2
9	90001942	Trailing Arm Rubber Bushing (Pre installed in Trailing Arms)	2
10	90002168	Strut Rod Spacers - 5/8" ID, 7/16" Thick	8
11	90002178	Trailing Arms Rubber Bushing T-bushings	4
12	99800002	5/8" -18 SAE RH Thread Jam Nut	2
13	99800003	5/8" -18 SAE LH Thread Jam Nut	2
14	90002175	5/8" -18 Flat Machine Bolt	2
15	70011824	Upper Crossmember Bushing (Pre installed in Crossmember)	2
	90002191	Trailing Arm Bushing Shim Kit (Not Shown)	1

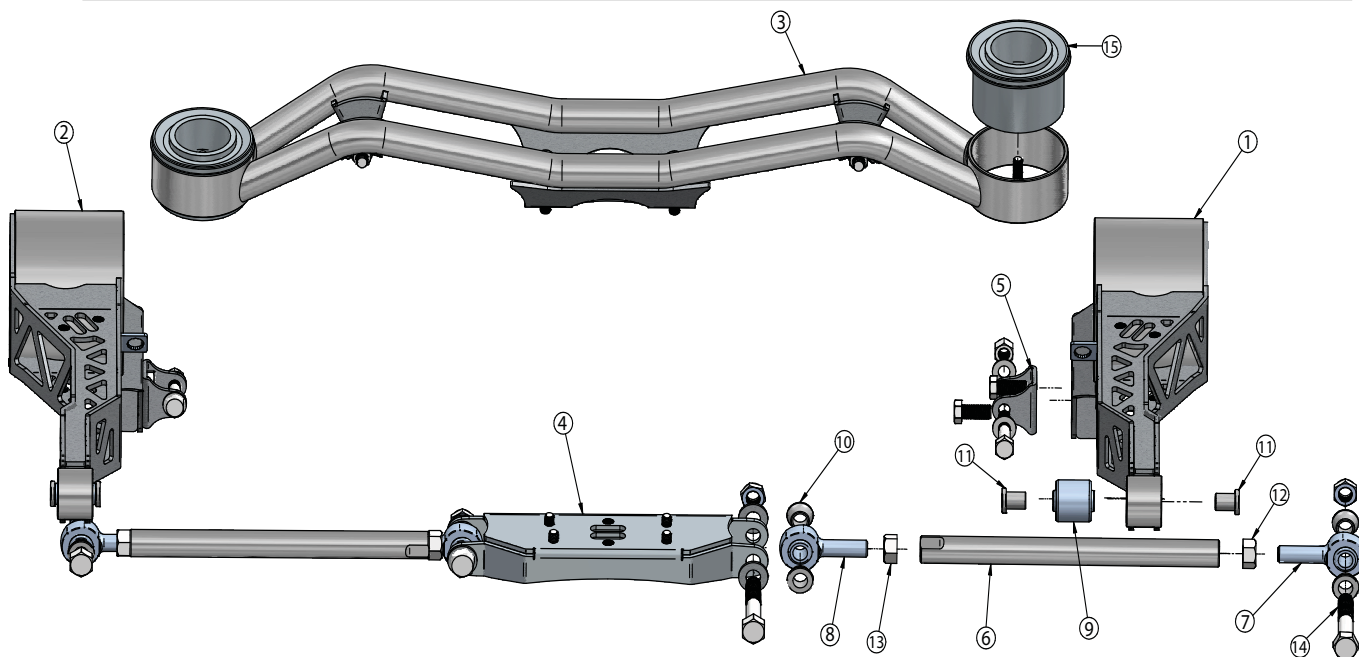



Hardware ListIn the box (Kit# 99010053)

QTY	Part Number	Description	
1	90002191	Shim Kit	Trailing Arm to Frame
2	99621003	5/8" x 2 3/4" Gr. 8 Bolt	Strut Rod to Strut Rod Mount
4	99622006	5/8" SAE Nylok Jam Nut	Strut Rod to Mounts
4	99623001	5/8" SAE Flatwasher	Strut Rod to Mounts
6	99431002	7/16" x 1 1/4" USS Bolt	Crossmember to Center Section & Frame
10	99433002	7/16" SAE Flatwasher	Crossmember to Center Section & Frame, Trailing Arm
8	99433003	7/16" Split Lock washer	Crossmember to Center Section & Frame, Trailing Arm
2	99431014	7/16" x 4 1/2" SAE Bolt	Trailing Arm to Frame
2	99432002	7/16" SAE Nylok Nut	Trailing Arm to Frame
4	99371003	3/8" x 1" USS Bolt	Strut Rod Mount to Center Section
4	99373005	3/8" Split Lock washer	Strut Rod Mount to Center Section
4	99373003	3/8" SAE Flatwasher	Strut Rod Mount to Center Section
8	99371043	3/8" x 3" SAE Bolt	OEM Hub to Trailing Arm
8	99372005	3/8" SAE Nylok Nut	OEM Hub to Trailing Arm
4	99501003	1/2" x 2 1/2" USS Bolt	Shocks to Mounts
4	99501019	1/2" x 1 1/4" USS Bolt	Shock Mounts to Trailing Arms
4	99503001	1/2" SAE Flatwasher	Shocks to Mounts
8	99502001	1/2" USS Nylok Nut	Shock Mount to Trailing Arm & Shocks to Mounts

Getting Started.....

Congratulations on your purchase of the Ridetech Rear StrongArm System. This system has been designed to give your Corvette excellent handling along with a lifetime of enjoyment. Some of the key features of this system: Trailing arms are designed to give more tire clearance, adjustability of ride height and ride quality, excellent handling.

Note: These system is designed for use with the Ridetech CoilOvers and the MuscleBar swaybar. **The factory shocks and springs will not fit this system.**



Disassembly and Upper Crossmember Installation

1. Raise the vehicle to a safe and comfortable working height.
2. Disassemble the rear suspension using the factory service manual as a reference. You will need to remove the Traverse Leaf Spring, Shocks, Half Shafts, Trailing arms, Center Section, Upper Crossmember, and Strut Rod Bracket from the Center Section.

NOTE: Keep the shims for the Trailing Arm in order and marked from where they were removed.

NOTE: You will need to disconnect the brake lines and parking brake cables(if equipped) on the OEM Brake Setup

3. With the rear suspension disassembled, remove the OEM Hub setup from the OEM Trailing Arms.

The OEM hubs will be used with the new Trailing Arms.



4. Attach the Upper Crossmember to the OEM Center Section using (4) 7/16"-14 x 1 1/4" Hex Bolts, (4) 7/16" Lock washers, and (4) 7/16" SAE Flatwashers.

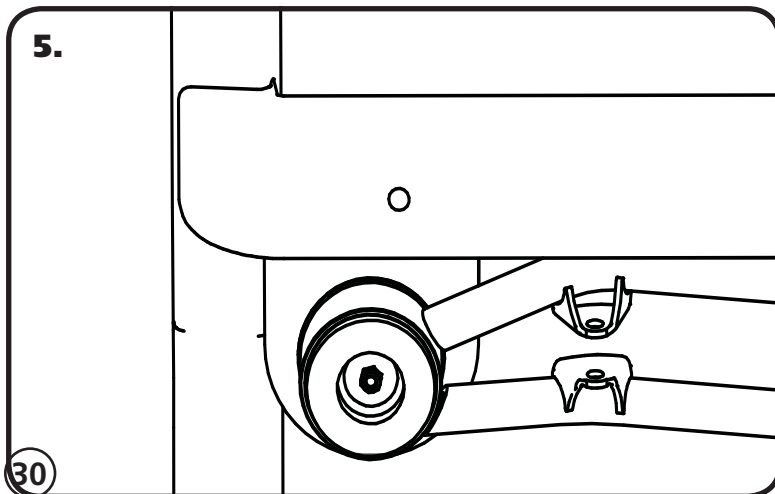

5. Install the Crossmember and Center Section into the car using (2) 7/16"-14 x 1 1/4" Hex Bolts, (2) 7/16" Lock washers, and (2) 7/16" SAE Flatwashers. With the Assembly installed in the car, reattach the U-joint and Front Center Section Support using the OEM hardware.



Strut Rod Bracket and Trailing Arm Installation

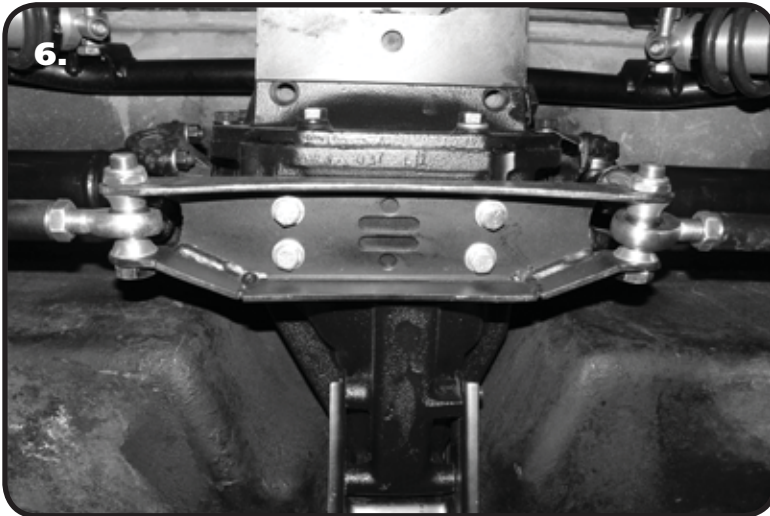

6. Install the Strut Rod Bracket onto the bottom of the OEM Center Section with the FLAT side to the rear of the car. Attach the bracket with (4) 3/8" x 1" Hex Bolts, (4) 3/8" SAE Flat-washers, and (4) 3/8" Split Lock washers.

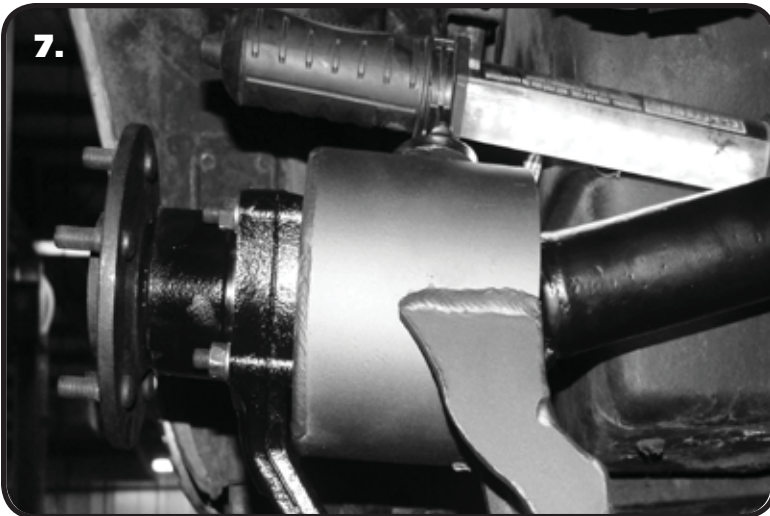

7. Install the OEM Hub Assembly using (4) 3/8"x 3" SAE Hex bolts, and (4) 3/8" SAE Nylok Nuts. The Drivers side Trailing Arm has the Shock Mount pointing down and facing the inside of the car. Do this for both sides.

Note: The Hub Assemblies are Driver and Passenger specific. The "D" shaped hole in the lower Strut Rod Mount faces the rear of the car.

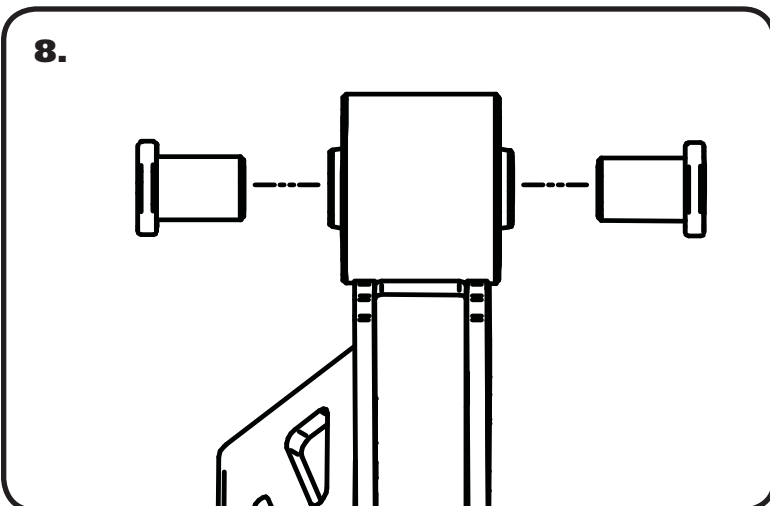

8. Install the T-bushings into the front Trailing Arm Bushings. Do this for both Trailing Arms.



Trailing Arm & Strut Rod Installation

9.

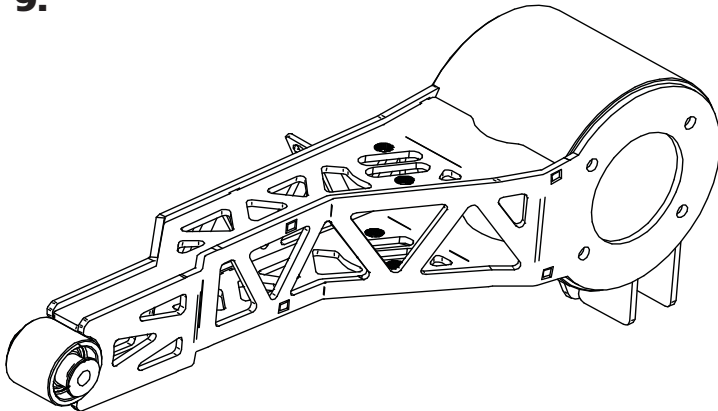

9. Install the Driver Trailing Arm Assembly into the stock location using (1) 7/16" x 4 1/2" Bolt, (1) 7/16" Flatwasher. Install New Shims that are supplied with the kit. The shim stacks should be the same thickness as the shim stacks that were removed from the OEM setup. Repeat for Passenger side.

Note: Driver Trailing arm is shown in Diagram "9". The shock mount will be on the bottom when the arm is installed correctly.

10.

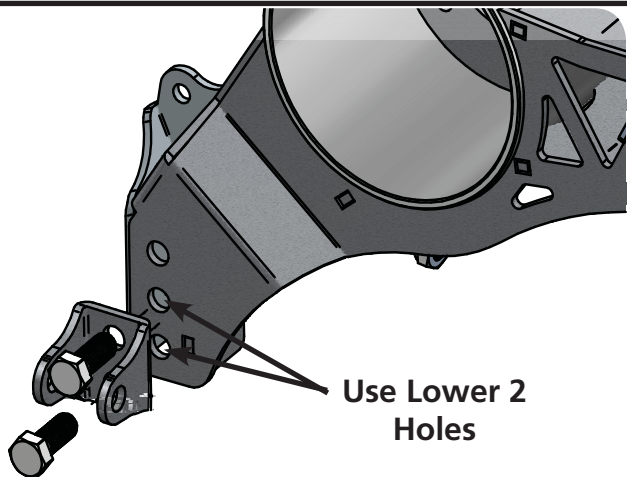

10. Attach the Shock Mounting Bracket to the lower 2 holes in the Trailing Arm. The Shock Mount is attached using (2) 1/2"-13 x 1 1/4" Bolts and (2) 1/2"-13 Nylok Nuts.

Note: The Upper 2 holes would be used if a 1" higher ride height would be desired.

11.

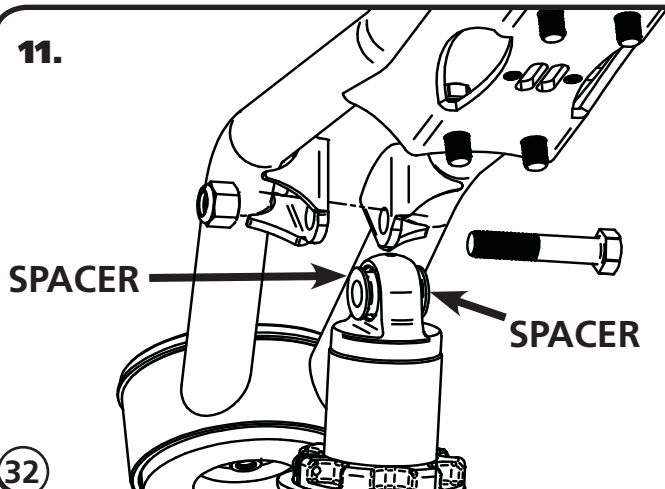

11. Install a spacer on each side of the upper Coilover. Slide the assembly into the upper crossmember from the bottom side. If your shock has an adjuster knob position it so that the knob points toward the center of the car. Line up the hole in the spacers with the hole in the upper shock bridge and insert 1/2" x 2 1/2" bolt and install 1/2" Nylok nut.



Shock Mount & CoilOver Installation

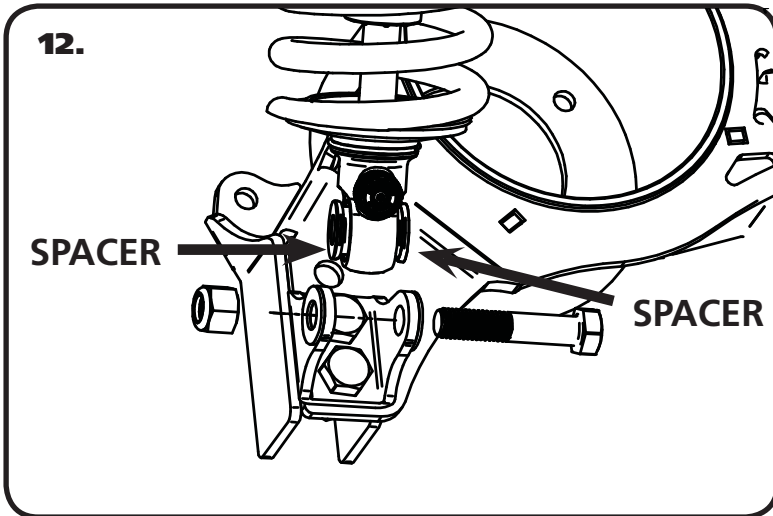

12. Install a spacer on each side of the lower Coilover. Slide the shock with the spacers installed into the mount on the lower Strong-Arm. You may need to jack the rearend up to line up the holes in the bushing with the 1/2" hole in the shock mounts and hold it in place while you install the 1/2" x 2 1/2" bolt and 1/2" Nylok nut. Tighten the upper and lower shock bolts.

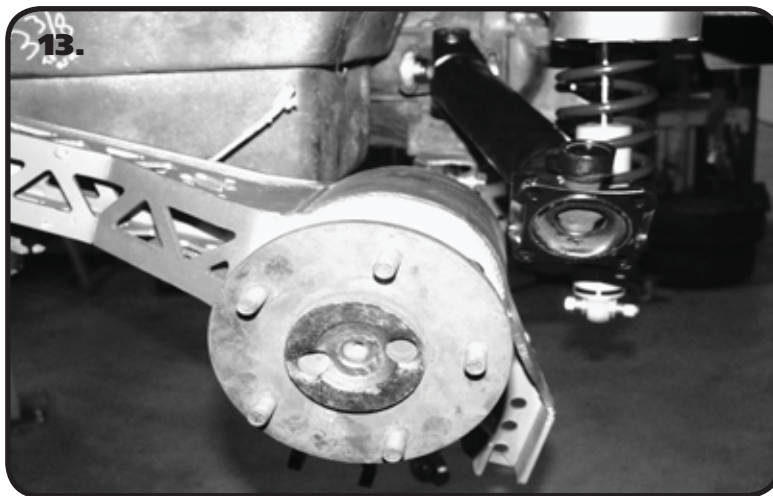

13. Reinstall the OEM Half Shafts using the OEM hardware.

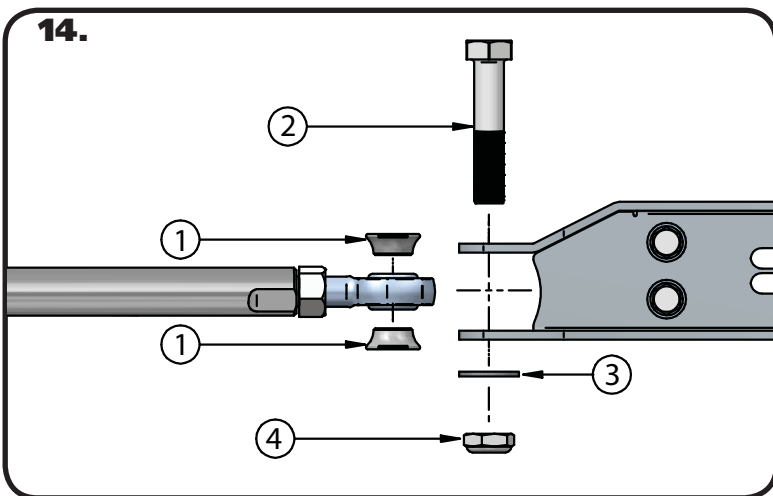

14. Install each Strut Rod using (4) 5/8" I.D. x 7/16" thick spacers, (1) 5/8" x 2 3/4 Hex Bolt, (1) 5/8" x 2 3/4" Hex Bolt with Machine Flat, (2) 5/8" Flatwasher (under nut), and (2) 5/8" Thin Nylok Nuts. The Strut is installed into the new Strut Rod Bracket located on the center section of the differential and the OEM Strut Rod Bracket attached to the OEM Hub. It is installed by inserting a 7/16" thick Spacer on each side of the heim end. The regular 5/8" Hex Bolt is used at the differential, the 5/8" Hex bolt with Machined Flat is installed in the hub side. The Machine Bolt is install with the threads pointing to the rear of the car.



Finishing

15. Reattach Brake lines and Emergency Brake Cables (Depends on year). Bleed the brakes before driving car. **Make sure the Parking Brake Cable doesn't interfere with the Brake Line.**

16. Tighten all fasteners. If you are going to install the Ridetech MuscleBar, now is a good time to do it.

17. Set ride height on the Corvette. The ride height of the Coilover is approximately 13". When using Coilovers, the ride height is done by using the adjuster nut for the coil spring. The coil spring on the Coilover will have some preload in the spring to get ride height, this is normal.

STILL HAVE QUESTIONS?

Tech line hours

Monday - Friday

8AM - 6PM (EST) 812-482-2932



Part # 11536510 - 1968-1979 C3 Rear CoilOvers



Recommended Tools

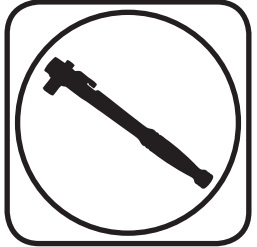

**1968-1979 C3 HQ Series Rear Coilovers
Installation Instructions**

Table of contents

Page 29..... Included Components

Page 30..... Assembly and Adjusting

Page 31..... Final Adjusting and Preloading the Spring



Major ComponentsIn the box

Item #	Part #	Description	QTY
1	24149999	4.1" Stroke HQ Series Shock	2
2	90002024	Shock Eyelet	2
4	59100325	Coilspring 10" 325lb	2
5	70010828	Delrin Spring Washer	4
6	90002222(kit)	Lower Spring Adjuster Nut (90002222 kit)	2
7	90002222(kit)	Adjuster Nut Locking Screw (90002222 kit)	2
8	90002222(kit)	Retaining Ring (90002222 kit)	2
	90001994	5/8" ID Bearing (installed in shock and eyelet)	4
	90001995	Bearing Snap Ring (installed in shock and eyelet)	8

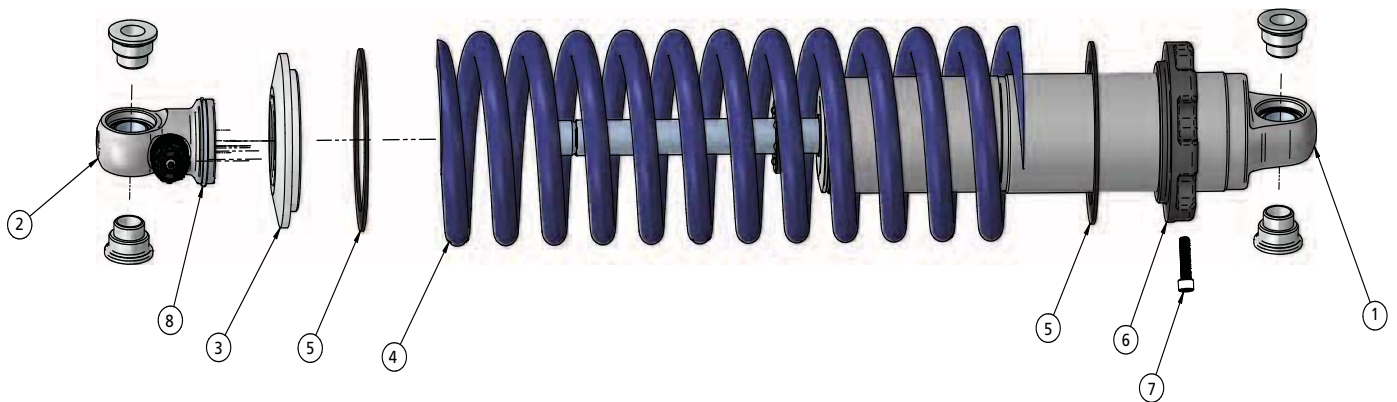



Assembly and Adjusting



1 First using the supplied lower adjuster nut(90002222) thread the nut onto the shock from the bottom side as seen in figure 1



4 Slide the Derlin washer over the spring, Next slide the upper spring mount (90002222) over eyelet as seen in figure 4.



2 Next install delrin washers then coil spring over the top of the shock as seen in figure 2



5 Install upper spring mount retainer clip (90002057) into the groove on the upper eyelet as seen in figure 5. Then reinstall adjuster to complete assembly.



3 Before the upper spring mount can be installed screw the adjuster knob on the upper eye mount to the firmest setting (clockwise) as seen in figure 3.



The included set of bearing spacers (900002044) are used to adapt the coil-overs to just about any application. The supplied spacers allow the coil-overs to accept 5/8" or 1/2" bolts.

Shock adjustment 101- Single Adjustable

Rebound Adjustment:

How to adjust your new shocks.

The rebound adjustment knob is located on the top of the shock absorber protruding from the eyelet.

You must first begin at the ZERO setting, then set the shock to a soft setting of 20.



-Begin with the shocks adjusted to the ZERO rebound position (full stiff). Do this by rotating the rebound adjuster knob clockwise until it stops.

-Now turn the rebound adjuster knob counter clock wise 20 clicks. This sets the shock at 20. (settings 21-24 are typically too soft for street use).

Take the vehicle for a test drive.



-if you are satisfied with the ride quality, do not do anything, you are set!

-if the ride quality is too soft increase the damping effect by rotating the rebound knob clock wise 3 clicks. **CONTINUE ON NEXT PAGE.**



Final Adjusting and Preloading Spring

Take the vehicle for another test drive.



-if the vehicle is too soft increase the damping effect by rotating the rebound knob clock wise 3 additional clicks.

-If the vehicle is too stiff rotate the rebound adjustment knob counter clock wise 2 clicks and you are set!

Take the vehicle for another test drive and repeat the above steps until the ride quality is satisfactory.

Note:

One end of the vehicle will likely reach the desired setting before the other end. If this happens stop adjusting the satisfied end and keep adjusting the unsatisfied end until the overall ride quality is satisfactory.

Final Tightening and Adjusting

Ride Height

We have designed most cars to have a ride height of about 2" lower than factory. To achieve the best ride quality & handling, the shock absorber needs to be at 40-60% overall travel when the car is at ride height. This will ensure that the shock will not bottom out or top out over even the largest bumps. Measuring the shock can be difficult, especially on some front suspensions. Measuring overall wheel travel is just as effective and can be much easier. Most cars will have 4-6" of overall wheel travel. One easy way to determine where you are at in wheel travel is to take a measurement from the fender lip (center of the wheel) to the ground. Then lift the car by the frame until the wheel is just touching the ground, re-measure. This will indicate how far you are from full extension of the shock. A minimum of 1.5" of extension travel (at the wheel) is needed to ensure that the shock does not top out. If you are more than 3" from full extension of the shock then you are in danger of bottoming out the shock absorber.

Adjusting Spring Height

When assembling the CoilOver, screw the spring retainer tight up to the spring (0 preload). After entire weight of car is on the wheels, jounce the suspension and roll the car forward and backward to alleviate suspension bind.

- If the car is too high w/ 0 preload then a smaller rate spring is required. Although threading the spring retainer down would lower the car, this could allow the spring to fall out of its seat when lifting the car by the frame.
- If the car is too low w/ 0 preload, then preload can then be added by threading the spring retainer up to achieve ride height. On 2.6" - 4" stroke shocks, up to 1.5" of preload is acceptable. On 5-7" stroke shocks, up to 2.5" of preload is acceptable. If more preload is needed to achieve ride height a stiffer spring rate is required. Too much preload may lead to coil bind, causing ride quality to suffer.



Part # 11539102 - 1968-1979 C3 Rear MuscleBar

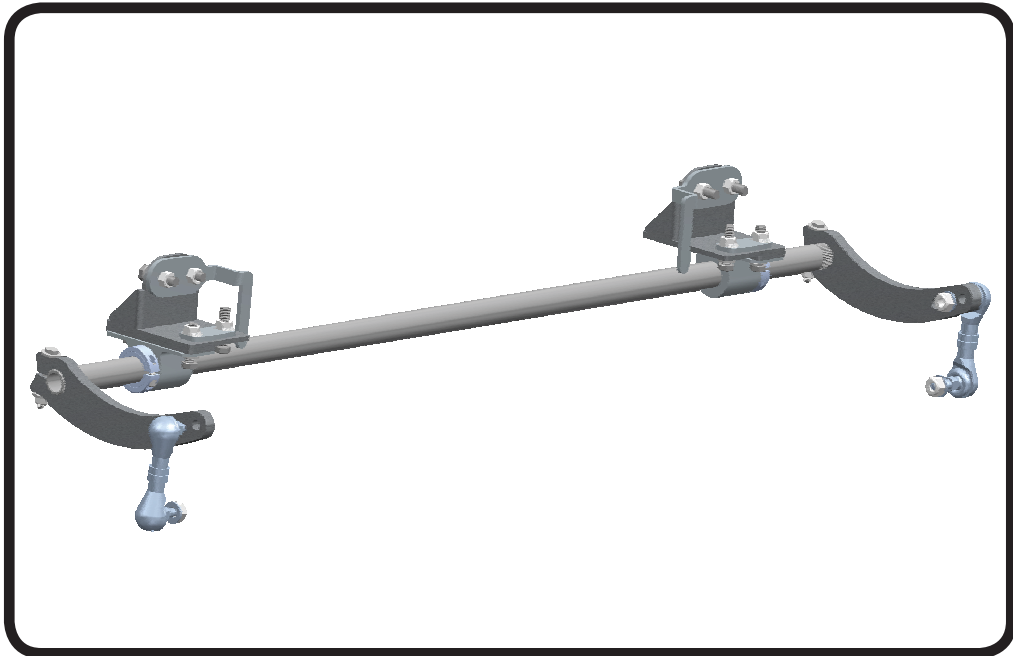

Recommended Tools

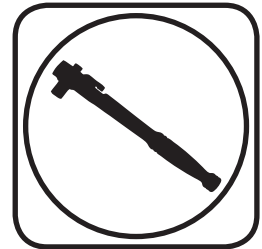

**1968-1979 C3 Rear MuscleBar
Installation Instructions**

Table of contents

- Page 40..... Included Components
- Page 41..... Hardware List & Getting Started
- Page 42..... MuscleBar Mounts Installation
- Page 43..... MuscleBar Installation
- Page 44..... Posilink and Arm Installation
- Page 45..... Final Assembly



Major ComponentsIn the box

Item #	Part #	Description	QTY
1	70011922	1.00" Splined MuscleBar	1
2	90002181	Spline MuscleBar Arm	2
3	99800004	Poly Bushing and Frame Bracket	2
4	70011970	Locking Ring	2
5	90000926	10mm 90 degree elbow (Preassembled Posilink)	4
6	99115001	M10-1.5 65mm stud (Preassembled Posilink)	2
7	90002176	MuscleBar Mount Assembly	2
8	90002177	MuscleBar Bushing Spacer	2
9	90002186	Nut Plate with Tab (Driver)	1
9	90002187	Nut Plate with Tab (Passenger)	1
10	90002185	Nut Plate NO Tab	2
	90001092	Tube of Lithium Grease (Not Shown)	1

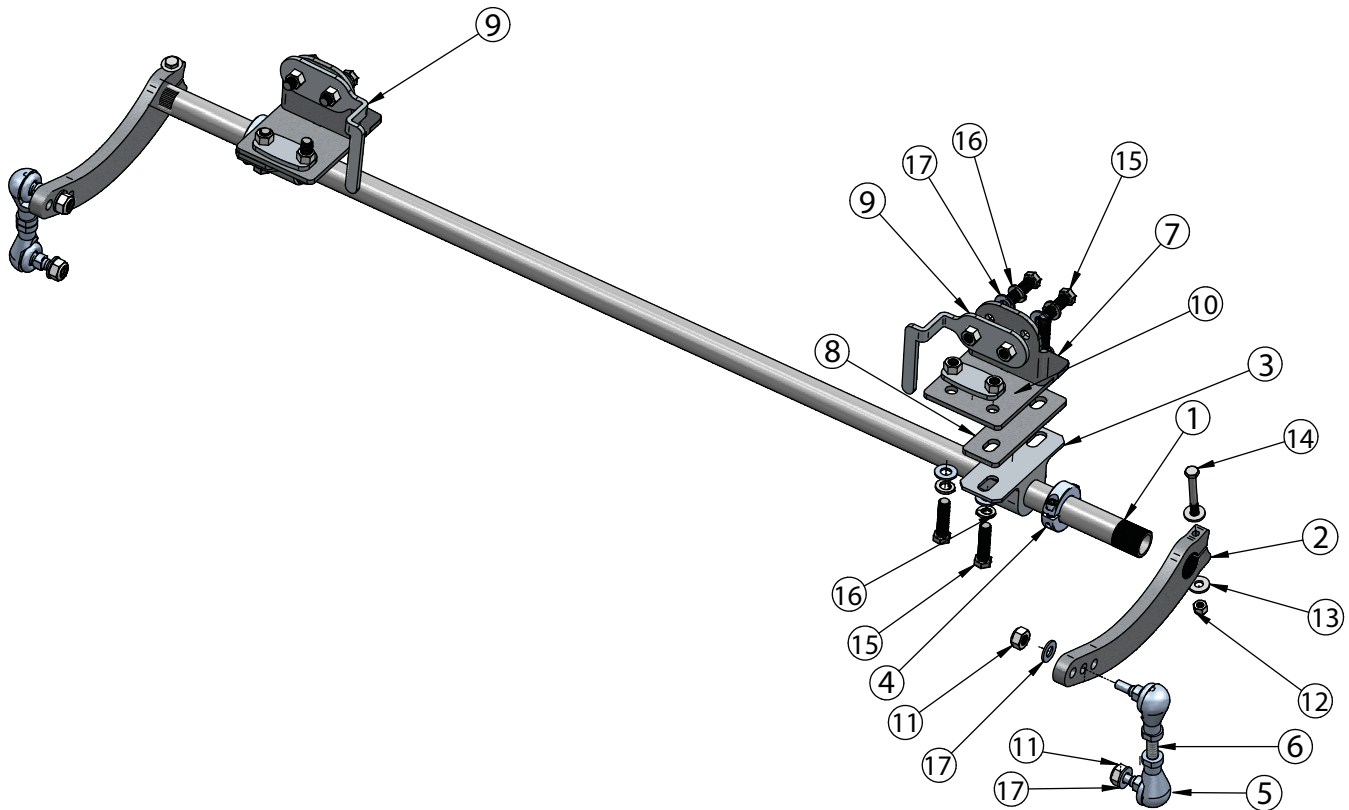



Hardware ListIn the box

Item #	QTY	Part Number	Description	Location
11	4	99112002	M10-1.5 Nylok Nut	Posilink to Swaybar and StrongArm
12	2	99252003	1/4"-20 Nylok Nut	MuscleBar Arm Pinch Bolt
13	4	99253008	1/4" SAE Flatwasher	MuscleBar Arm Pinch Bolt
14	2	99251011	1/4"-20 x 2 1/4" Hex Bolt	MuscleBar Arm Pinch Bolt
15	10	99371006	3/8"-16 x 1 1/2" Hex Bolt	MuscleBar Mount & Bushing to Frame
16	8	99373005	3/8" Split Lock washer	MuscleBar Mount & Bushing to Frame
17	16	99373003	3/8" SAE Flatwasher	MuscleBar Bushing to Frame & Posilink
	2	99372002	3/8"-16 Nylok Nut	MuscleBar Bushing to Mount (Not Shown)

Getting Started.....

Congratulations on your purchase of the Ridetech Rear MuscleBar. This kit has been designed to give your Corvette excellent handling along with a lifetime of enjoyment. Some of the key features of this MuscleBar: Posilinks - The Posilink makes the reaction of the swaybar instantaneous, tunability - this Musclebar has 3 positions to aid in the tuning of the handling of your Corvette.

Note: This MuscleBar is designed to be used with the Ridetech Rear StrongArm kit.

THE REAR MUSCLEBAR KIT WILL **NOT WORK WITH A SPARE TIRE IN THE STOCK LOCATION.**

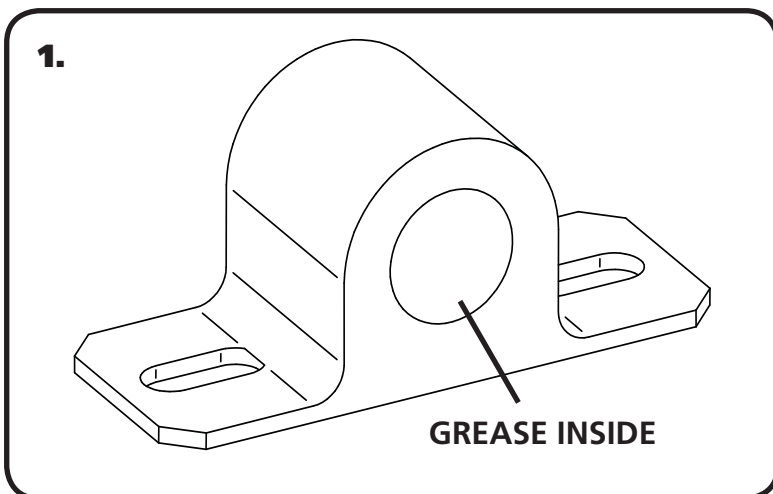

1. Apply Lithium grease to the inside of the sway bar bushings using the tube of grease supplied in the kit.



MuscleBar Mounts Installation

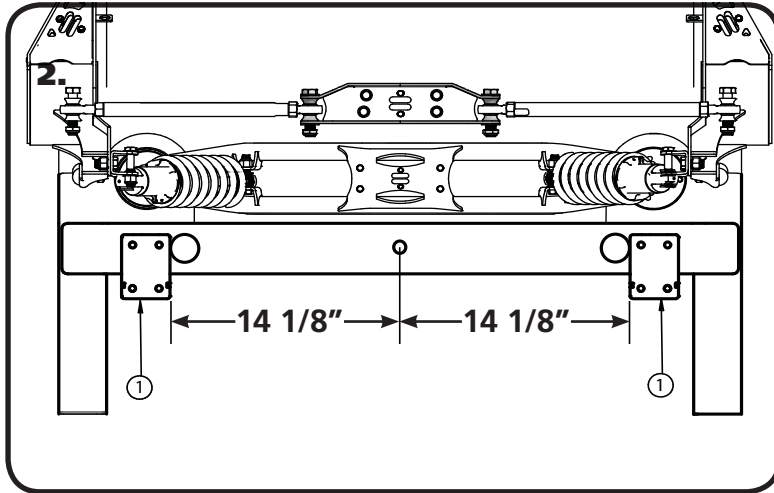

C3 MuscleBar Mounts

2. The holes for the MuscleBar Mounts(1) will need to be drilled in the OEM Crossmember. The Mounts are positioned 14 1/8" from the center of the Crossmember. Use the Mounts as a template for drilling the holes in the Crossmember. Position the mount 14 1/8" from the center of the crossmember to the inside edge of the mount. The TOP OUTER hole will line up with a Factory hole in the crossmember. Mark remaining 3 holes and drill with a 7/16" drill bit. Do this for both brackets.

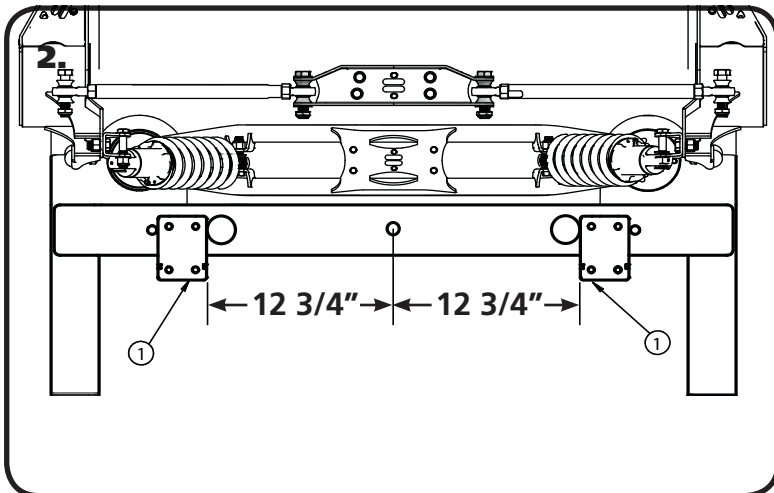

C2 MuscleBar Mounts

2. The holes for the MuscleBar Mounts(1) will need to be drilled in the OEM Crossmember. The Mounts are positioned 12 3/4" from the center of the Crossmember. Use the Mounts as a template for drilling the holes in the Crossmember. Position the mount 12 3/4" from the center of the crossmember to the inside edge of the mount. Mark the 4 holes and drill with a 7/16" drill bit. Do this for both brackets.

Note: The Driver and Passenger Mounting Brackets are identical.

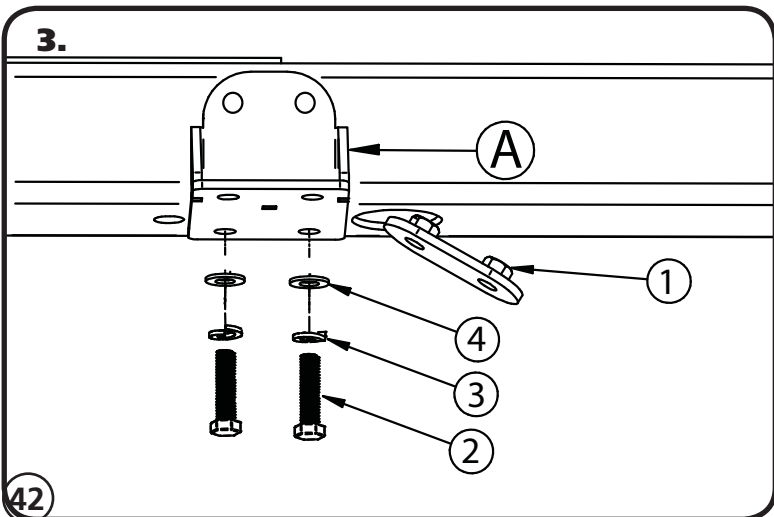

3. Insert the Nut Plate (1) through the large hole in the crossmember and line it up with the holes drilled in the previous step. Hold the MuscleBar Mount in place (A). Thread a 3/8" x 1 1/2" Hex Bolt (2), with a 3/8" Split Lock washer(3), and 3/8" Flatwasher (4) installed on the Bolt, into each bottom hole. Tighten the inner bolt leaving the outer bolt loose. The outer bolt will be used to attach the MuscleBar in a later step.



MuscleBar Installation

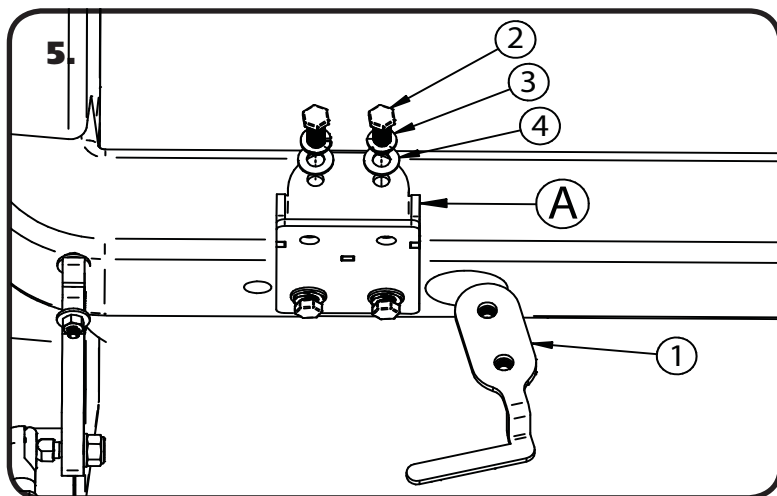

4. Insert the Nut Plate with Tab(1) through the large hole in the crossmember and line it up with the holes drilled in the previous step. Thread a 3/8" x 1 1/2" Hex Bolt (2), with a 3/8" Split Lock washer(3), and 3/8" Flatwasher (4) installed on the Bolt, into each bottom hole. Tighten both bolts. Do this for both sides

Note: When positioned correctly, the Tab on the Nut Plate is bent away from the mounting surface.

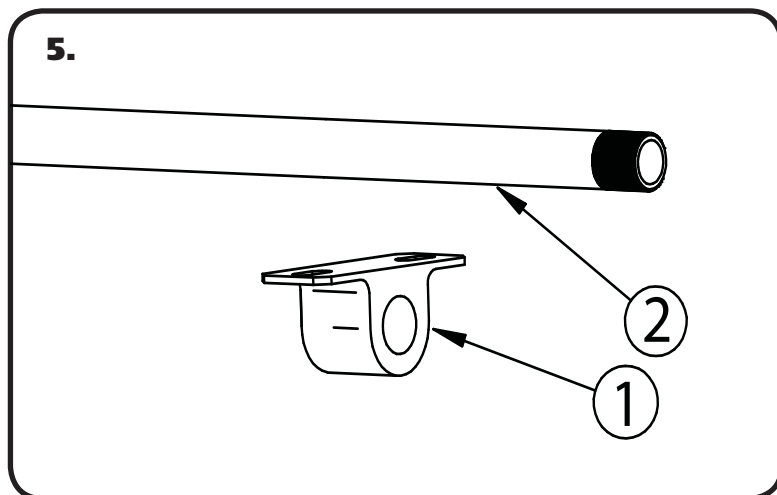

5. Install the MuscleBar Bushings and Straps on the MuscleBar. They are positioned approximately - **5" on C2, 3 1/2" on C3** - from the end of the MuscleBar to the outside edge of the bushing. To install the Bushing, remove the Mounting Strap from the Bushing. Open the Bushing at the slice on the edge of the Bushing. Slide the Bar through the slice. Re-install the Mounting Strap.

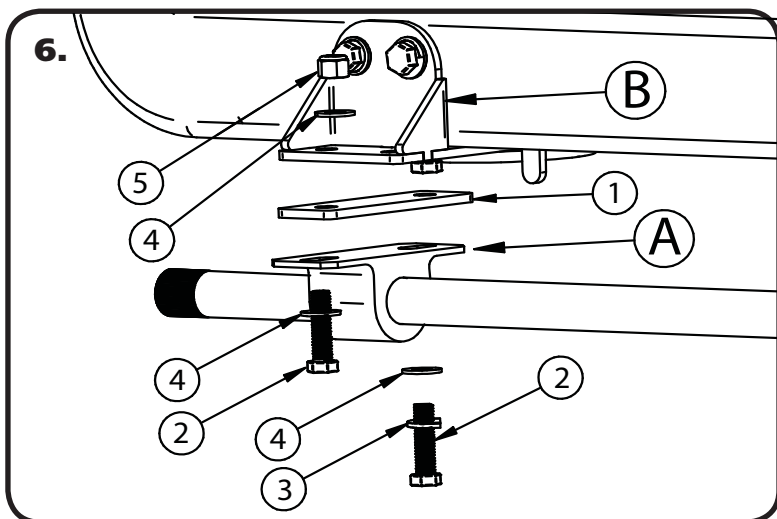

6. Install the MuscleBar onto the Mounts using the supplied Spacer(1) between the Bushing(A) and the Mount(B). Insert a 3/8" x 1 1/2" Hex Bolt(2), 3/8" Split Lock washer(3), and a 3/8" Flatwasher(4) in the front Bushing Assembly hole. In the rear of the Bushing Assembly, insert a 3/8" x 1 1/2" Hex Bolt(2) and 3/8" Flatwasher(4) from the bottom. Install a 3/8" Flatwasher(4) and 3/8" Nylok Nut(5) on the Bolt from the top. Leave the retainers loose enough that the bar can be moved in the bushings.



PosiLink and Arm Installation

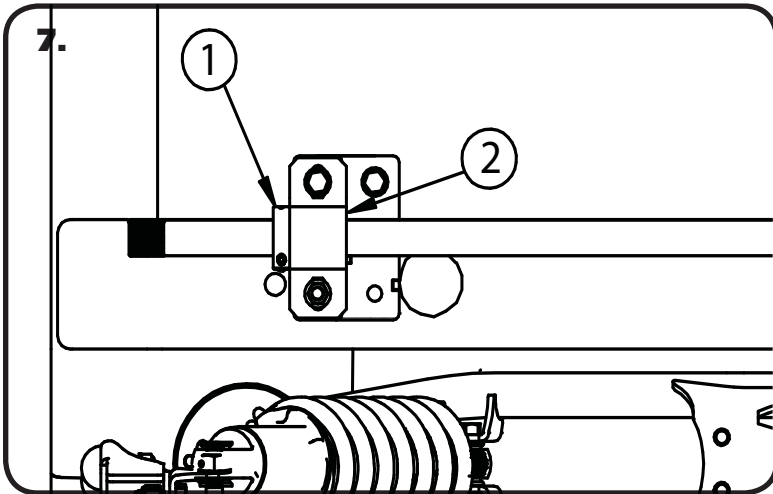

7. Center the bar by measuring from the edge of the Bushings to the end of the bar. With the bar centered, tighten the Bushing Assembly hardware. Install a Locking Collar(1) on each end of the MuscleBar(2). Slide the Locking Collars against the Bushings and Tighten the Collar.

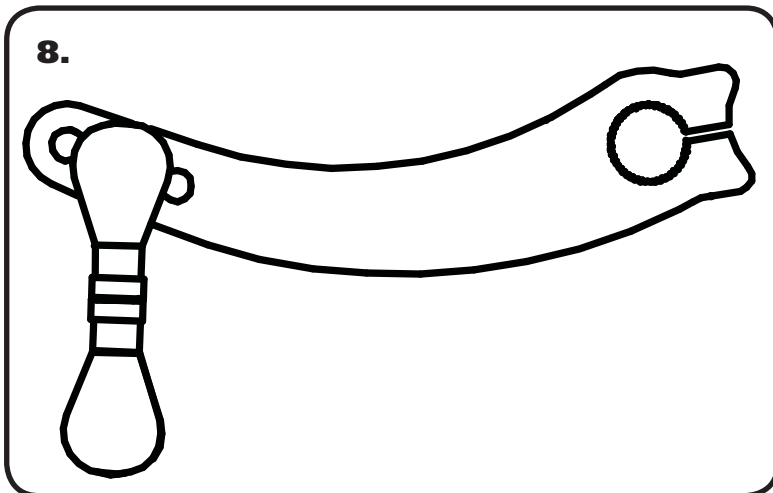

8. Install a PosiLink Assembly into the center hole on each MuscleBar arm. **Install the Posilinks in opposite sides of the 2 arms.** Install a 3/8" Flatwasher on the Threaded Stud of the Posilink, insert the Stud into the Arm. Install a 3/8" Flatwasher and 10mm Nylok Nut onto the Stud and tighten.

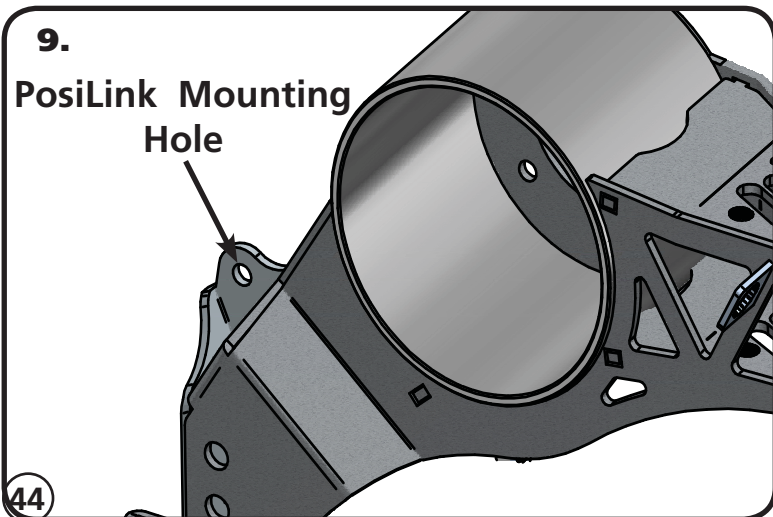

9. **This step needs to be done with the complete rear suspension installed on the car.** It is critical to get the arms clocked on the MuscleBar the same, we found a simple way to do it. With the StrongArms hanging at full extension, slide the MuscleBar arms onto the bar. Try to insert the loose end of the Posilink into the mounting hole on the StrongArm. If it will not slide into the hole, remove the Swaybar arm from the bar and reposition it until the Posilink will slide into the mounting hole with little effort. Repeat the procedure on the other side. The arms are now clocked the same.



Final Installation

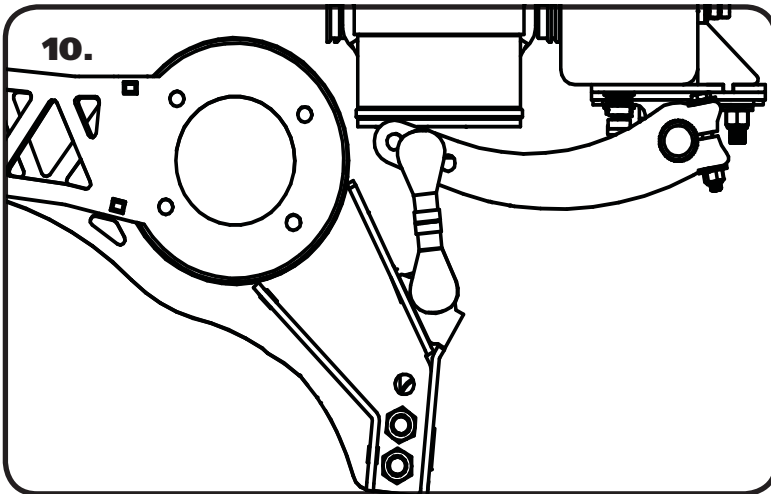

10. With both arms clocked, the Posilinks can be permanently attached to the StrongArm. Install a 3/8" Flatwasher on the Threaded Stud of the Posilink, insert the Stud into the Arm. Install a 3/8" Flatwasher and 10mm Nylok Nut onto the Stud and tighten.

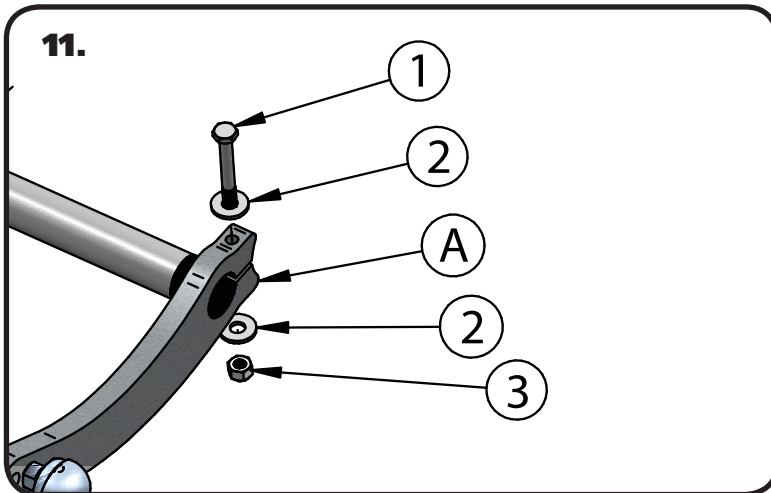

11. Position the Arm(A) so that it is even with the ends of the splines. Install 1/4"-20 x 2 1/4" bolt(1), along with a Flatwasher(2), through the hole vertical hole in the Muscle-Bar arm. Install a Flatwasher(2) and 1/4" Nylok nut(3) on the threads and tighten to 12 ft lbs.

13. Double check all hardware to make sure its tight.

The MuscleBar has 3 positions to aid in the tuning of your Corvette's handling. We start in the center position and tune from there. The Position to the rear of the car will make the Musclebar stiffer. The position to the front of the car will make the MuscleBar softer.

Note: If any grease is needed after installation use a lithium based grease. **DO NOT USE A PETROLEUM BASED GREASE**

STILL HAVE QUESTIONS?

Tech line hours

Monday - Friday

8AM - 6PM (EST) 812-482-2932

www.ridetech.com

812-482-2932