



350 S. St. Charles St. Jasper, In. 47546

Ph. 812.482.2932 Fax 812.634.6632

www.ridetech.com

Part # 11320299
78-88 GM "G" Body Level 2 Air Suspension System

Front Components:

1	11323001	HQ Series Front Shockwaves for Strong Arms
1	11329599	Front Tru-Turn Suspension Package

Rear Components:

1	11325401	HQ Series Rear Shockwaves
1	11324499	Rear Lower Strong Arms
1	11320701	HQ Series Rear Shocks

Compressor System:

1	30334100	5 gallon LevelPro Compressor Kit
---	----------	----------------------------------



350 S. St. Charles St. Jasper, In. 47546
Ph. 812.482.2932 Fax 812.634.6632
www.ridetech.com

Part # 11323001
78-88 GM "G" Body Front HQ Series Shockwaves
For Use w/ StrongArms

ShockWave Assembly:

2	24090399	104mm Master Series rolling sleeve assembly
2	24139999	3.6" stroke HQ Series shock
2	90001994	.625" I.D. bearing
4	90001995	Bearing snap ring
2	90009988	Short Delrin stud top – 2.00"
2	70008913	Locking Ring

Components:

2	90002312	Short Delrin stud top base – 2.00"
2	90001902	Aluminum cap for Delrin ball
2	90001903	Delrin ball upper half
2	90001904	Delrin ball lower half
2	31954201	¼"npt x ¼" tube swivel elbows

Hardware:

2	99562003	9/16" SAE Nylok jam nut	Stud top hardware
---	----------	-------------------------	-------------------

SHOCKwave[®]

by Air Ride Technologies

Installation Instructions



1. For air spring clearance some trimming must be done on the outer portion of the coil spring pocket. The amount of trimming necessary will vary from one car to another, it is best to install the Shockwave onto the lower arm and inflate the bellow. Check clearance throughout full suspension travel. **(Inflated diameter of this Shockwave is approximately 6.5")**

4. This is best done with a cut off wheel or plasma cutter. Make the cuts round, square corners will create a fracture point.

Allowing the shockwave will rub will result in failure, this is not a warrantable situation.



7. Apply thread sealant to a 90 degree air fitting and screw it into the top of the Shockwaves. The fitting location can be rotated by twisting the bellow while holding the shock body.

8. Place the Shockwave up into the coil spring pocket with the stud protruding through the factory shock hole. **See assembly diagram on next page.**

9. Fasten the Shockwave to the factory lower control arm using the 1/2" x 3 1/4" bolt, Nylok nut & aluminum spacers supplied w/ the StrongArms.

13. The best ride quality will occur around 50-60% suspension travel; depending on vehicle weight this typically occurs around 100-110 psi.

SHOCKwave[®]

by Air Ride Technologies

1. Stud top aluminum base
2. Delrin ball lower half
3. Delrin ball upper half
4. Aluminum cap
5. 9/16" SAE Nylok jam nut
6. Threaded stud (screwed onto shock shaft)
7. Rebound adjusting knob
8. Screw

The Factory shock hole will have to be drilled out to $\frac{3}{4}$ " and the stud top assembled like the diagram you see here.

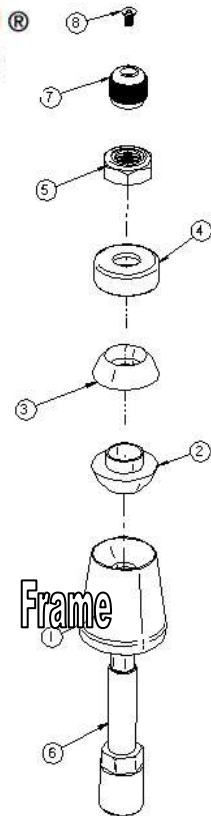

The care and feeding of your new ShockWaves

1. Although the ShockWave has an internal bumpstop, **DO NOT DRIVE THE VEHICLE DEFLATED RESTING ON THIS BUMPSTOP. DAMAGE WILL RESULT.** The internal bumpstop will be damaged, the shock bushings will be damaged, and the vehicle shock mounting points may be damaged to the point of failure. **This is a non warrantable situation.**
2. Do not drive the vehicle overinflated or "topped out". Over a period of time the shock valving will be damaged, possibly to the point of failure. **This is a non warrantable situation!** If you need to raise your vehicle higher than the ShockWave allows, you will need a longer unit.
3. The ShockWave is designed to give a great ride quality and to raise and lower the vehicle. **IT IS NOT MADE TO HOP OR JUMP!** If you want to hop or jump, hydraulics are a better choice. This abuse will result in bent piston rods, broken shock mounts, and destroyed bushings. **This is a non warrantable situation.**
3. Do not let the ShockWave bellows rub on anything. Failure will result. **This is a non warrantable situation.**
4. The ShockWave product has been field tested on numerous vehicles as well as subjected to many different stress tests to ensure that there are no leakage or durability problems. Failures have been nearly nonexistent unless abused as described above. If the Shockwave units are installed properly and are not abused, they will last many, many years. **ShockWave units that are returned with broken mounts, bent piston rods, destroyed bumpstops or bushings, or abrasions on the bellows will not be warrantied.**



350 S. St. Charles St. Jasper, In. 47546
Ph. 812.482.2932 Fax 812.634.6632
www.ridetech.com



Part # 11329599 78-88 GM "G" Body Tru-Turn Suspension Package

Front Components:

- | | | |
|---|----------|-------------------|
| 1 | 11323699 | Upper Strong Arms |
| 1 | 11322899 | Lower Strong Arms |
| 1 | 11329500 | Tru Turn System |

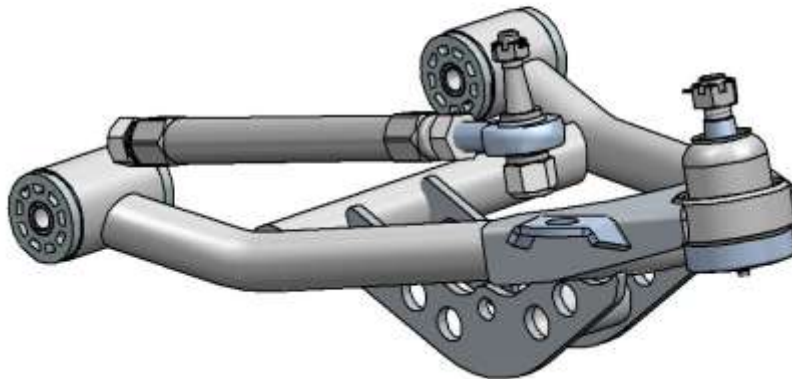
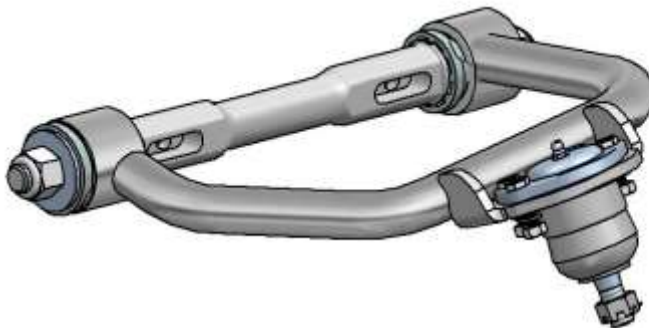



350 S. St. Charles St. Jasper, In. 47546

Ph. 812.482.2932 Fax 812.634.6632

www.ridetech.com

Part # 11323699
78-88 GM "G" Body Upper StrongArms

Components:

1	90002379	Drivers side arm
1	90002380	Passenger side arm
2	90000913	Upper ball joint
2	90000914	Caster Adjustable Cross shaft
2	70010826	Delrin Bushing – no ledge
2	70010827	Delrin Bushing – small ledge
4	70010759	Delrin Bushing – outer
4	70010807	Zero Offset Caster Slugs

Hardware:

4	99163001	Stainless Washer	Cross shaft to bushing
4	99622005	5/8" SAE crimp locking nuts	Cross shaft to bushing
4	99431009	7/16-14 x 2 1/2" Hex Bolt	Cross shaft to Frame
4	99432001	7/16"-14 Nylok Nut	Cross shaft to Frame
4	99433002	7/16" SAE Flatwasher	Cross shaft to Frame

STRONG ARMS™

by Air Ride Technologies



1. Fasten the upper arm to the frame using the factory hardware. Reinstall the current alignment shims, but **vehicle must be realigned.**

2. Drop ball joint down through upper arm. Slide ball joint boot over stud, then place boot retainer over the boot. Clamp assembly tight w/ the hardware supplied.

3. Fasten the ball joint to the spindle w/ the new castle nut and cotter pin supplied.

4. Tighten the cross shaft nuts enough to create drag on the delrin bushings, the arm should still move.

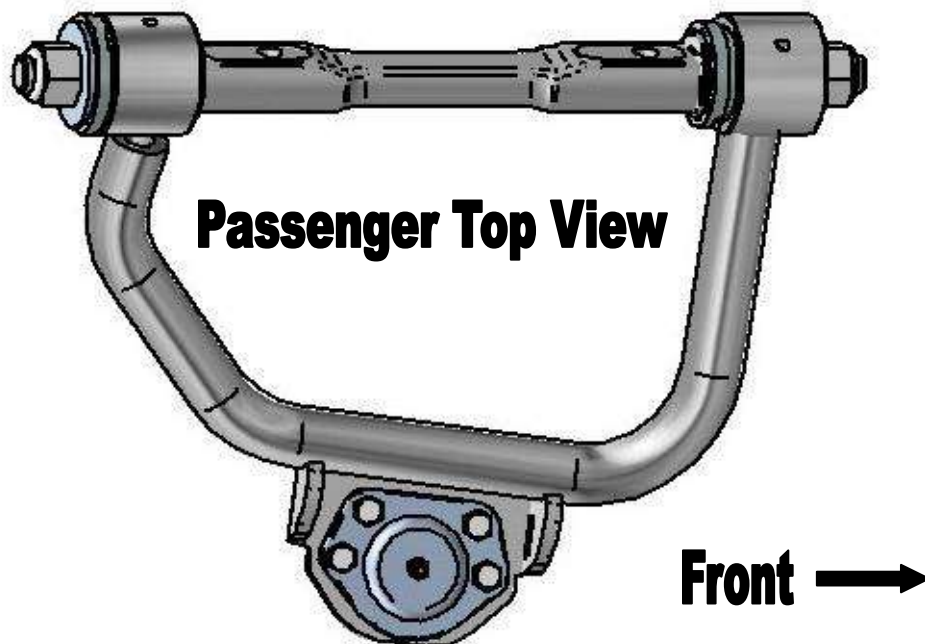

Passenger Side – Top View

Item #	Description	Qty.
1.	5/8 – 18 Toplock Jam Nut	4
2.	Outer Washer	4
3.	Outer Delrin bushing	4
4.	Passenger side arm	1
4.	Driver side arm	1
5.	Inner Delrin bushing w/ledge	2
6.	Caster Adjustable Cross shaft	2
7.	Caster Slug	2
8.	Inner Delrin bushing no ledge	2

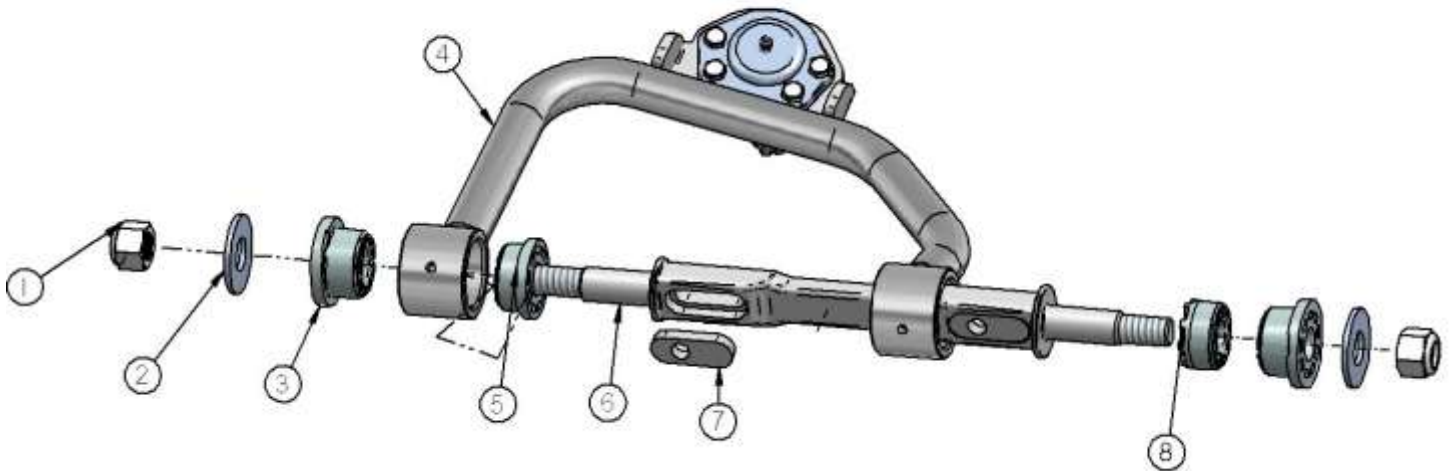

STRONG ARMS™

by Air Ride Technologies

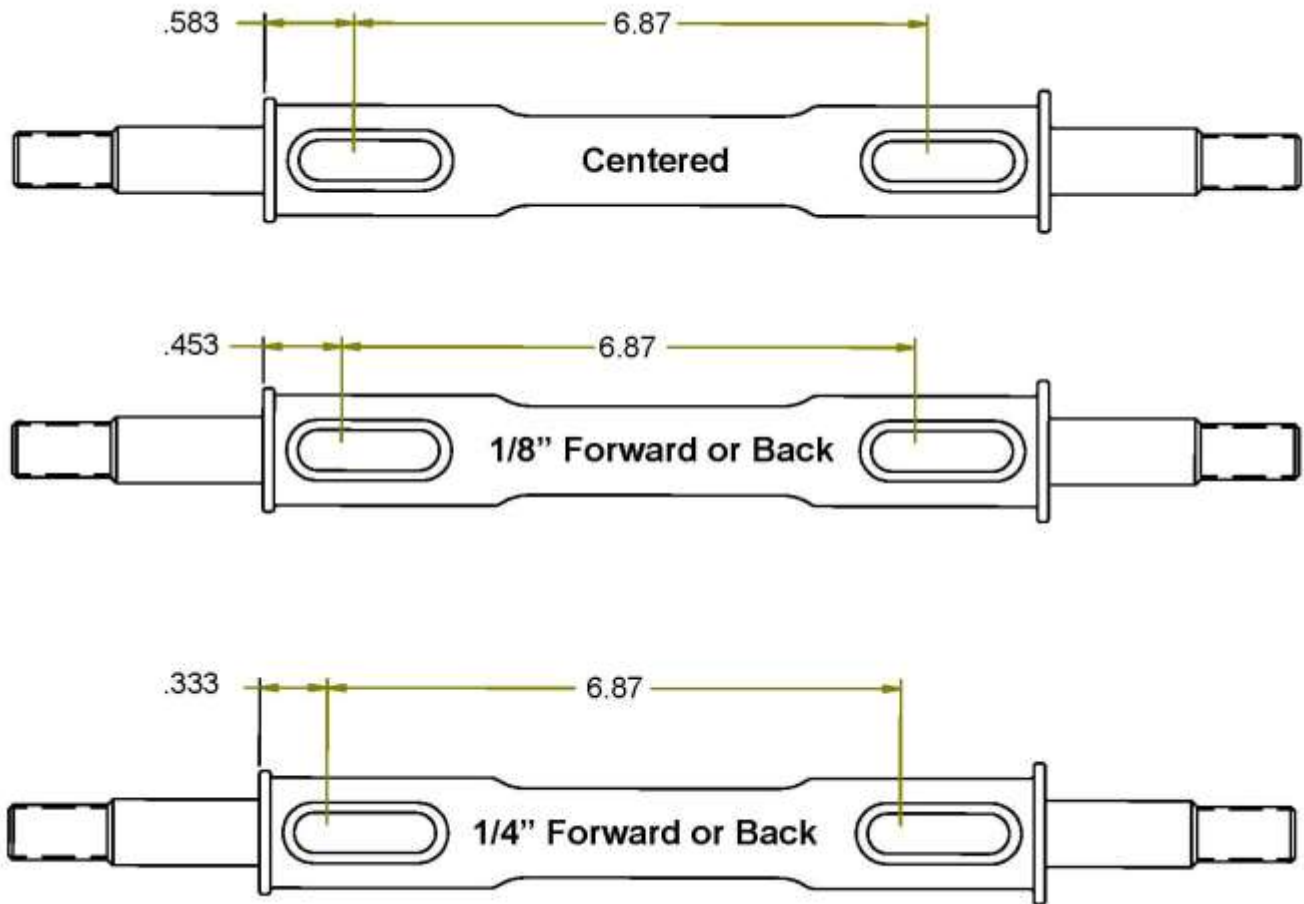

These Strong Arms come equipped with a changeable caster slug setup. This allows you to add or remove caster from the front suspension, if desired. The caster slugs that come in the kit are setup to put the control arm in the centered position, which is approximately 5 degrees of caster. The caster slugs allow you to add or remove caster without having to use a stack of shims. If more or less caster is desired, optional caster slugs can be purchased from your Ridetech dealer or Ridetech.

Caster Explained:

To understand caster you need to picture an imaginary line that runs through the upper ball joint and extends through the lower ball joint. From the side view the imaginary line will tilt forward or backward. The tilting of this imaginary line is defined as caster.

Caster is measured in degrees by using a caster camber gauge. If the imaginary line described above tilts towards the back of the car, at the top, then you will have positive caster. If the imaginary line tilts forward then you would have negative caster.

Positive caster provides the directional stability in your car. Too much positive caster will make the steering effort difficult. Power steering will allow you to run more positive caster. Negative caster requires less steering effort but can cause the car to wander down the highway.

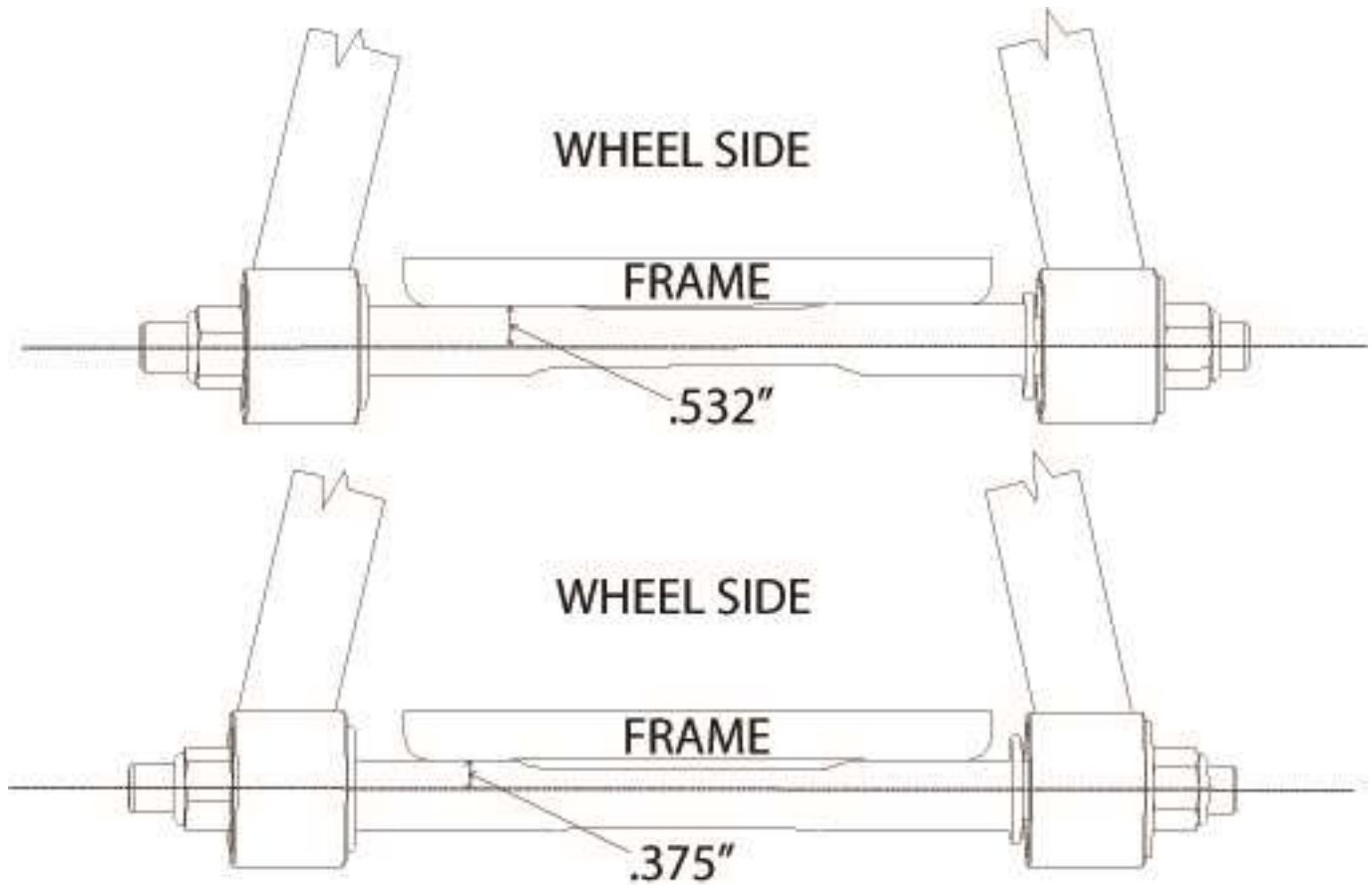

Offset Upper Cross Shaft

The cross shaft that is used in the upper control arm is offset. The offset combined with the caster slug option allows you to achieve the alignment setting you desire with minimal shims. To change the direction that the Icon faces, simply spin the cross shaft in the control arm.

If you are after an aggressive **Track or Autocross Alignment**, bolt the control arm to the frame bracket with the arm offset to the inside of the car (like the top illustration). The Ridetech Icon will be facing the engine.

If a **Street Alignment** is desired, bolt the control to the frame bracket with the arm offset to the outside of the car (like the bottom illustration). The Ridetech Icon will be facing the wheel.



350 S. St. Charles St. Jasper, In. 47546

Ph. 812.482.2932 Fax 812.634.6632

www.ridetech.com

Part # 11322899

78-88 GM "G" Body Lower StrongArms

For Use w/ Shockwaves or CoilOvers

Components:

1	90002377	Driver side lower arm
1	90002378	Passenger side lower arm
2	90000896	Ball joint
2	90000572	Inner bushing sleeve
2	90000573	Inner bushing sleeve
8	70010759	Delrin bushing half
4	90002062	Aluminum spacer – Shock to lower arm

Hardware:

2	99501024	½"-13 x 3 ¼" Gr.5 bolt	Shockwave to lower arm
2	99502001	½"-13 Nylok nut	Shockwave to lower arm

STRONG ARMS™

by Air Ride Technologies

Installation Instructions



1. After removing the factory lower control arm, clean the bushing mounting surfaces on the frame to make sure they are fairly smooth.
2. Fasten the lower arm to the frame with the factory hardware.

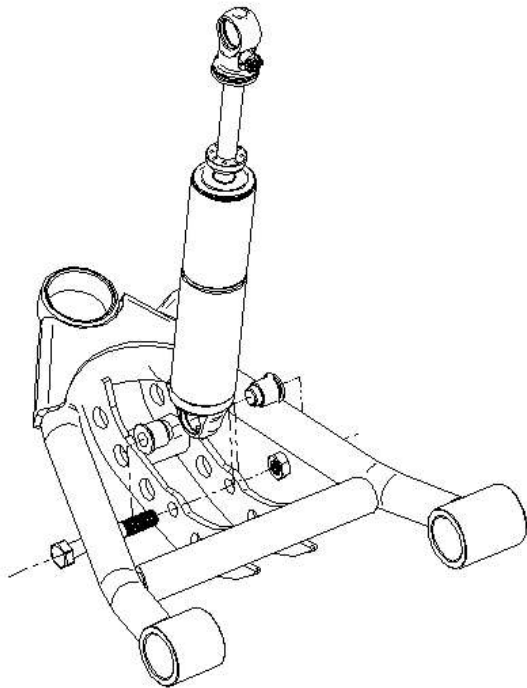

3. Swing the lower StrongArm up to the shock and secure with the $\frac{1}{2}$ " x $\frac{3}{4}$ " bolt and Nylok nut, an aluminum spacer must be installed on each side of the bearing.
4. Slide the ball joint boot over the stud, then push the stud up through the spindle. Secure w/ the new castle nut and cotter pin supplied.
5. Grease the ball joints.

STRONG ARMS™

by Air Ride Technologies

Item #	Description	Qty.
1.	Driver side arm	1
2.	Ball Joint	1
3.	Inner bushing sleeve – narrow	1
4.	Inner bushing sleeve – wide	1
5.	Delrin bushing half	2
6.	Delrin bushing half	2
7.	Aluminum bearing spacer	2
8.	1/2"-13 x 3 1/4" bolt	1
9.	1/2"-13 Nylok nut	1

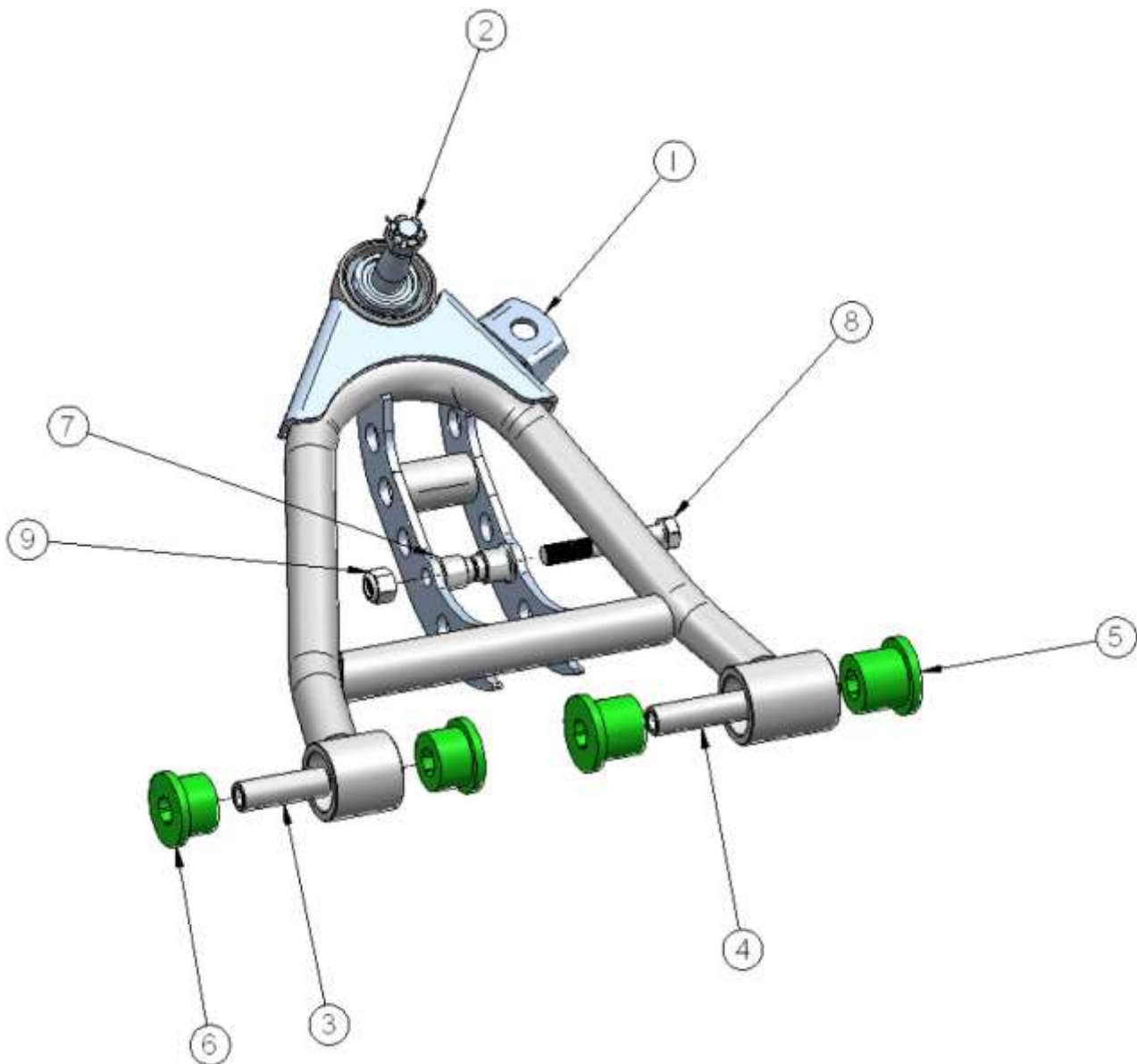



Air Ride Technologies

350 S. St. Charles St. Jasper, In. 47546

Ph. 812.482.2932 Fax 812.634.6632

www.ridetech.com

Part # 11329500
78-88 G-Body TruTurn System without Spindles



Item #	Part #	Description-Specification	Qty.
1.	90001590	Heim end	2
2.	99800002	5/8"-18 RH jam nut	2
3.	90002373	Heim End Spacer	4
4.	99622003	5/8"-18 Lock Nut-100 ft lbs	2
5.	90002374	Tie Rod Stud	2
6.	99432005	7/16"-20 castle nut-35 ft lbs	2
7.	90002375	Adjusting sleeve	2
8.	99952002	3/32" cotter pin	2
9.	99800003	5/8"-18 LH jam nut	2

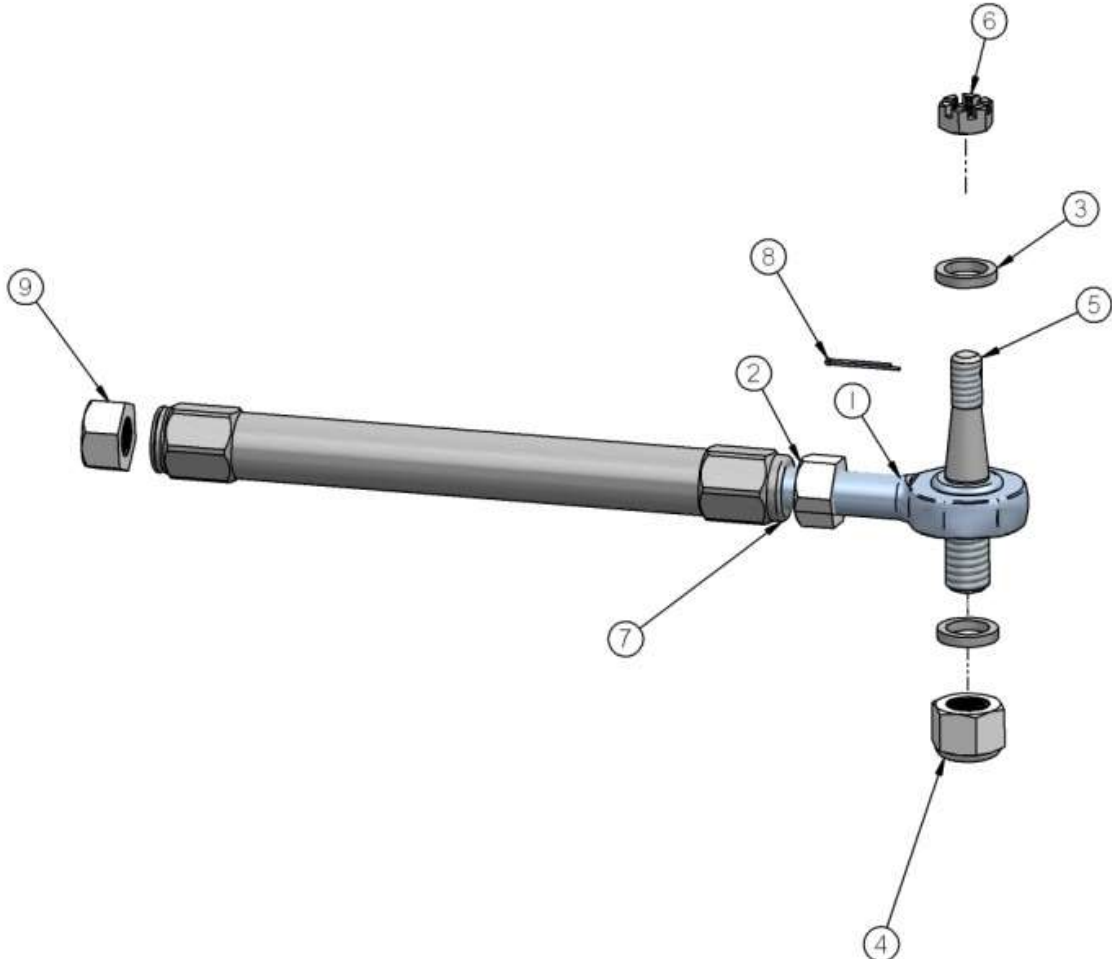



350 S. St. Charles Street Jasper, In. 47546 www.ridetech.com

Installation instructions:

NOTE: The number in (#) is the number of the part in the drawing on the previous page.

1. Raise and safely support the front of your vehicle at a comfortable working level
2. Remove existing outer tie rod and adjuster leaving the inner tie rod.
3. Install the (5) Tie Rod Stud into your factory spindle using the (6)7/16" castle nut. Torque the nut to 35 ft lbs and install (8) cotter pin. **NOTE:** If none of the holes line up tighten the nut until you can get the hole to line up with a slot.
4. Install the (7) Right Hand thread nut onto the (1) heim end and (9) Left hand nut onto the factory tie rod.
5. Antiseize the threads on the factory tie rod and heim end to prevent the threads from galling.
6. The left hand threaded side of the (7) adjuster goes onto the factory tie rod; it has a groove cut into the end of the adjuster. You will want the thread engagement the same on the tie rod end and the heim, the easy way to do this is set then nut on the tie rod 1 1/4" from the end of the tie rod and thread the adjuster on so that it touches the nut.
7. Install the heim end into the other end of the adjuster. Start by threading the lock nut all the way on the heim end and thread the heim end into the adjuster so that it touches the nut.
8. Install the heim end side of the tie rod onto the tie rod stud using the (3) aluminum spacer on top and bottom of the heim end and then install the (4)5/8" lock nut. Torque nut to 100 ft lbs.
9. Set the center to center length of the tie rod assembly to 17 3/4" by turning the adjuster out. This will get you close on the toe setting but it will need to be aligned.
10. Adjust the camber and toe roughly until you can get the vehicle to a proper alignment shop. The recommended alignment settings are:

Camber - -.5 to -1.5 [within .3 from side to side]

Caster - 4 to 7 degrees positive

Toe - 1/16" to 1/8" toe in

Feel free to experiment with alternative alignment settings that may be more appropriate for your particular driving style.

Installation notes:

- A. **MAKE SURE** that the cotter pins are properly installed in all appropriate places [C] to ensure that the castle nuts do not become loose and fail. These are VERY important connections!



350 S. St. Charles St. Jasper, In. 47546

Ph. 812.482.2932 Fax 812.634.6632

www.ridetech.com

Part # 11326699
78-88 GM "G" Body Rear Upper StrongArms

Components:

2	90001118	Upper StrongArm (Set to 11.125")
2	90001589	Kevlar lined Heim end
4	90002065	Aluminum spacers for Heim end

Hardware:

2	99752004	3/4" SAE Jam nut	Heim end
4	99501006	1/2" x 3 1/2" USS Gr. 8 bolt	StrongArms
4	99502001	1/2" USS Gr. 8 Nut	StrongArms

STRONG ARMS™

by Air Ride Technologies

Installation Instructions



1. The length of the upper bar should be set from the factory at 11.125" center to center. Ensure that the jam nut is tight.
2. Using the factory hardware, fasten the heim end to the frame bracket. An aluminum spacer must be installed on each side of the Heim end.



3. Fasten the other end of the bar to the axle using the factory hardware.
- Note:** Inspect the rubber bushing in the axle for wear or cracked. Replace with factory replacement bushing if needed.



350 S. St. Charles St. Jasper, In. 47546

Ph. 812.482.2932 Fax 812.634.6632

www.ridetech.com

Part # 11324499
78-88 GM "G" Body Rear Lower StrongArms

Components:

2	90001021	Lower StrongArm – WW 19.25"
8	90001089	Poly bushing half – .75" I.D. x 1.5" O.D. x 1.125" long
4	90000516	Bushing sleeve - .5" I.D. x .75" O.D. x 2.375" long
2	90001092	Tube of Lithium grease – to lubrication bushing mounting surfaces

Hardware:

4	99431003	7/16" x 3" USS bolt	Swaybar to lower bars
4	99432001	7/16" USS Nylok nut	Swaybar to lower bars
8	99433002	7/16" SAE flat washer	Swaybar to lower bars
4	99501006	1/2" x 3 1/2" USS Gr. 8 bolt	StrongArms to frame
4	99502001	1/2" USS Gr. 8 Nylok nut	StrongArms to frame

STRONG ARMS™

by Air Ride Technologies

Installation Instructions



1. Remove the sway bar (if equipped) and factory lower trailing arm. Do one side at a time to keep the axle from rotating.
2. Clean bushing mounting surfaces on frame. Lubricate w/ lithium grease supplied.
2. Attach to front on the lower StrongArm to the frame using factory hardware.
3. This arm has holes in the tube for sway bar attachment. Mount the bar so that the holes are closest to the axle.



4. Attach to rear of the lower StrongArm to the frame using the factory hardware.
- Note:** These polyurethane bushing are lubricated at the factory w/ lithium grease.
- Note:** Tighten the bolts enough to remove any lateral movement and apply moderate drag on bushings. Over-tightening can cause excessive suspension bind.



350 S. St. Charles St. Jasper, In. 47546
Ph. 812.482.2932 Fax 812.634.6632

www.ridetech.com

Part # 11325401
78-88 GM "G" Body Rear ShockWave Kit
Single Adjustable

Shockwave Assembly:

2	24159999	5" stoke single adjustable shock
2	24090799	7000 Series sleeve assembly
2	70008913	Locking ring for bellow
2	90002024	1.7" Eyelet –adjustable
4	90001994	.625" bearing
8	90001995	Bearing snap ring

Components:

2	31954201	¼" npt x ¼" tube elbow airline fitting
8	90002043	Aluminum spacer - .5" I.D.
2	90002327	Upper shock bracket
1	90002325	Driver side lower shock bracket
1	90002326	Passenger side lower shock bracket

Hardware:

4	99311001	5/16"-18 x 1" Gr. 5 bolt	Upper bracket to frame
4	99312001	5/16"-18 Nylok nut	Upper bracket to frame
8	99313002	5/16" SAE flat washer	Upper bracket to frame
2	99501027	1/2"-13 x 3 ¾" Gr. 5 bolt	Shock bracket to trailing arm bracket
2	99501002	1/2"-13 x 1 ½" Gr.5 bolt	Shock bracket to factory shock bracket
4	99501003	1/2"-13 x 2 ½" Gr. 5 bolt	Shock to upper & lower brackets
8	99502001	1/2"-13 Nylok nut	Lower shock bracket
8	99503001	1/2" SAE flat washer	Lower shock bracket

SHOCKwave®

Installation Instructions

1. Raise and safely support the vehicle by the frame rails.
2. Using a jack, slightly raise the axle approximately 1". Remove the shock absorbers.
3. Lower the axle down enough to remove the coil springs.
4. The exhaust tail pipes may need to be removed and/or modified for Shockwave installation.



5. Fasten the new upper shock bracket into the factory shock location using the 5/16" x 1" bolts, flat washers and Nylok nuts supplied.

Note: Position the bracket to offset the shock toward the center of the car.



6. Remove the lower trailing arm mounting bolt. (Do one side at a time to keep the axle from rotating).

7. Place the new lower shock bracket up against the factory lower shock bracket. Use a 1/2" x 1 1/2" bolt, Nylok nut and flat washers to fasten the new bracket to the factory bracket. Install the longer 1/2" x 3 3/4" bolt through the lower trailing arm mount, secure w/ the supplied flat washers and Nylok nuts.



8. Install the aluminum spacers into the upper and lower eyes of the shock.



9. Apply thread sealant to a 90 degree air fitting and screw it into the top of the ShockWave. The air fitting location can be rotated by twisting the bellow separate of the shock.

10. Fasten the ShockWave to the upper bracket using a $\frac{1}{2}$ " x $2\frac{1}{2}$ " bolt and Nylok nut.

11. Fasten the ShockWave to the lower bracket using a $\frac{1}{2}$ " x $2\frac{1}{2}$ " bolt and Nylok nut.

12. Double check air spring clearances throughout full suspension travel.

13. Ride height on this ShockWave is 14.5" from center eye to center eye.

SHOCK*wave*®

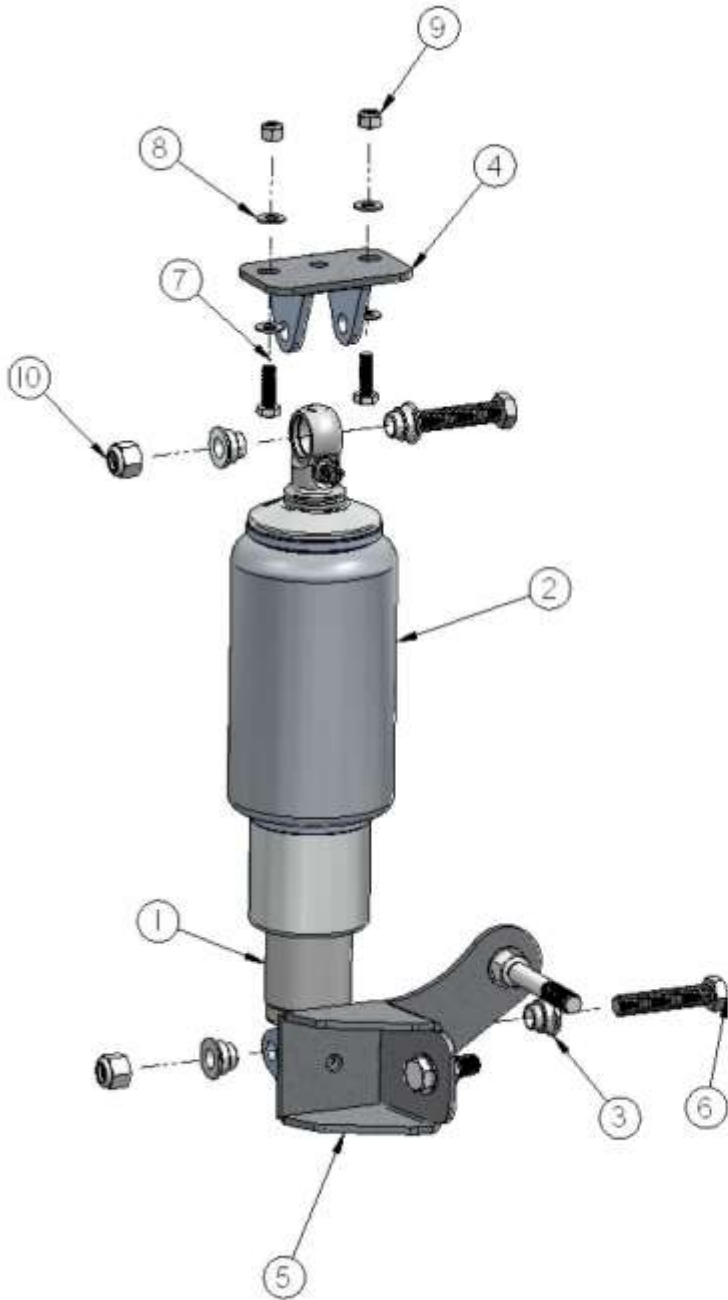

Item #	Description	Qty.
1.	5" stroke monotube shock	2
2.	7000 Series bellow assembly	2
3.	.5" I.D. aluminum spacer	8
4.	Upper shock mount	2
5.	Lower shock mount	2
6.	1/2"-13 x 2 1/2" bolt	4
7.	5/16"-18 x 1" bolt	4
8.	5/16" SAE flat washer	8
9.	5/16"-18 Nylok nut	4
10.	1/2"-13 Nylok nut	8
11.	1/2"-13 x 1 1/2" bolt	2
12.	1/2"-13 x 3 3/4" bolt	2
13.	1/2" SAE flat washer	8

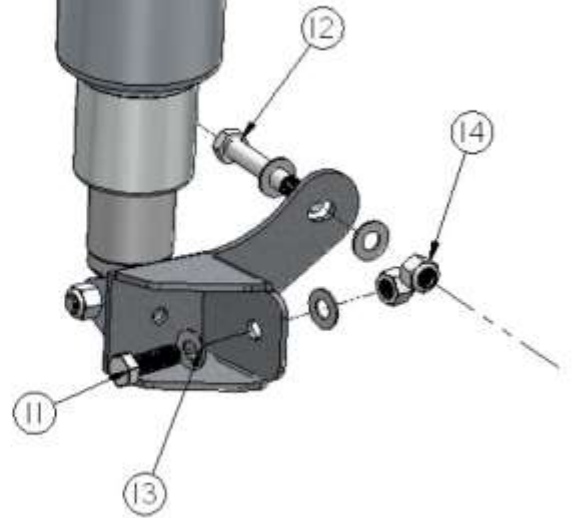



Part # 30334100 - 3 Gallon LevelPro Compressor System

Recommended Tools



Components:

2	31920020	Thomas 319 Compressor
1	31934001	4 way RidePro air valve assembly
1	31913100	3 gallon Aluminum tank
5	31988150	Air pressure sensor
1	31398001	RidePro LevelPro ECU
1	31398002	RidePro LevelPro Display
2	99064002	6-32 x 3/8" Phillips pan head screw for display
1	82010000	Installation Guide

Wiring & Hardware:

1	31900031	Display Harness
1	31900020	Air valve wiring harness
1	31900006	Air pressure sensor wiring harness
1	31900048	Main power / compressor harness
2	90001924	Fuse holder
2	90001922	20 Amp fuse
6	99104001	10-24 x 1" phillips screw
6	99102002	10-24 Nylok nut
6	99103001	#10 SAE flat washer
2	90001913	12-10 Gauge Butt Connector
2	90001916	#10 x 5/16" Ring Terminal

Airlines & Fittings:

2	31940002	1/4" DOT airline – 30' roll
6	31954201	1/4" npt x 1/4" tube elbow fitting - air springs / tank
7	31954000	1/4" npt x 1/4" tube straight fitting - air valve
2	31952150	1/8" npt female x 1/4" tube straight fitting - compressor
2	31957003	1/8" npt nipple (install between FIT2150 & compressor)
3	31957004	1/4" npt plug - plug extra supply port
1	31954400	1/4" air line tee- compressors to check valve fitting
1	31959301	Check Valve- SCREWS INTO TANK FOR COMPRESSOR LINE

THE CHECK VALVE SUPPLIED SCREWS INTO THE AIR TANK WITH AN AIR FITTING THREADING INTO IT. THE COMPRESSOR LINES WILL FEED INTO THE CHECK VALVE.



Shock adjustment 101- Single Adjustable

Rebound Adjustment:

How to adjust your new shocks.

The rebound adjustment knob is located on the top of the shock absorber protruding from the eyelet.

You must first begin at the ZERO setting, then set the shock to a soft setting of 20.



-Begin with the shocks adjusted to the ZERO rebound position (full stiff). Do this by rotating the rebound adjuster knob clockwise until it stops.



-Now turn the rebound adjuster knob counter clock wise 20 clicks. This sets the shock at 20. (settings 21-24 are typically too soft for street use).

Take the vehicle for a test drive.



-if you are satisfied with the ride quality, do not do anything, you are set!



-if the ride quality is too soft increase the damping effect by rotating the rebound knob clock wise 3 clicks.

Take the vehicle for another test drive.



if the vehicle is too soft increase the damping effect by rotating the rebound knob clock wise 3 additional clicks.



-if the vehicle is too stiff rotate the rebound adjustment knob counter clock wise 2 clicks and you are set!

Take the vehicle for another test drive and repeat the above steps until the ride quality is satisfactory.

Note:

One end of the vehicle will likely reach the desired setting before the other end. If this happens stop adjusting the satisfied end and keep adjusting the unsatisfied end until the overall ride quality is satisfactory.