



350 S. St. Charles St. Jasper, In. 47546

Ph. 812.482.2932 Fax 812.634.6632

www.ridetech.com

Part # 11260299

68-74 GM "X" Body Level 2 Complete Air Suspension System

Front Components:

1	11163001	HQ Series Front Shockwaves
1	11162899	Front Lower StrongArms
1	11163699	Front Upper StrongArms
1	11009300	RideTech Tall Spindles

Rear Components:

1	11267199	Rear AirBar – Bolt-on 4 Link
1	21150701	Rear HQ Series Shockwaves

Compressor System:

1	30334100	5 gallon LevelPro Compressor Kit
---	----------	----------------------------------



350 S. St. Charles St. Jasper, In. 47546
Ph. 812.482.2932 Fax 812.634.6632
www.ridetech.com

Part # 11163001
68-74 GM "X" Body Front HQ Series Shockwaves
For Use w/ StrongArms & RideTech Spindles

ShockWave Assembly:

2	24090399	104mm Master Series rolling sleeve assembly
2	24139999	3.2" stroke HQ Series shock
2	90001994	.625" I.D. bearing
4	90001995	Bearing snap ring
2	90009989	Tall Delrin stud top – 2.75"

Components:

2	90002309	Tall Delrin stud top base – 2.75"
2	90001902	Aluminum cap for Delrin ball
2	90001903	Delrin ball upper half
2	90001904	Delrin ball lower half
2	31954201	¼"npt x ¼" tube swivel elbows

Hardware:

4	99562003	9/16" SAE Nylok jam nut	Stud top hardware
---	----------	-------------------------	-------------------

Installation Instructions



1. To allow clearance for the Shockwave, some trimming must be done on the inside of the coil spring pocket as shown by the white line in the picture. This is best done with either a cut off wheel or plasma cutter. Grind all cuts smooth when finished.

Note: It may be helpful to go ahead and install the lower StrongArms and Shockwaves to determine exactly what needs to be removed.



2. The Shockwave stud top will come in contact with the coil spring retainer, so it must be opened up towards the engine. A die grinder works well here.



3. Some trimming must also be done on the outside of the frame pocket to allow clearance for the Shockwave.
4. Apply thread sealant to a 90 degree air fitting and screw it into the top of the Shockwave. The air fitting location can be rotated by twisting the bellow assembly separate of the shock.
5. Place the Shockwave into the coil spring pocket with the stud sticking through the OEM shock hole. See assembly diagram below.

Note: The airline must also be routed at this time. It can be ran through the subframe toward the rear of the vehicle.

1. Tall Delrin stud top base
2. Delrin ball lower half
3. Delrin ball upper half
4. Aluminum cap
5. 9/16" SAE jam nut
6. Tall Delrin stud top
7. Black adjustment knob
8. Detent clip
9. Screw
10. Washer

6. Raise the lower arm up to the Shockwave and bolt them together using the 1/2" x 3 1/4" bolt and Nylok supplied w/ the lower arms. An aluminum spacer will be on each side of the bearing.

7. Raise the lower control arm to full compression and double-check to make sure the Shockwave does not rub on anything at anytime. **Allowing the Shockwave to rub on anything will cause failure and is not a warrantable situation.**

8. The best ride quality will occur around 50-60% suspension travel; depending on vehicle weight this typically occurs around 85-100 psi.



The care and feeding of your new ShockWaves

1. Although the ShockWave has an internal bumpstop, **DO NOT DRIVE THE VEHICLE DEFLATED RESTING ON THIS BUMPSTOP. DAMAGE WILL RESULT.** The internal bumpstop will be damaged, the shock bushings will be damaged, and the vehicle shock mounting points may be damaged to the point of failure. **This is a non warrantable situation.**
2. Do not drive the vehicle overinflated or “topped out”. Over a period of time the shock valving will be damaged, possibly to the point of failure. **This is a non warrantable situation!** If you need to raise your vehicle higher than the ShockWave allows, you will need a longer unit.
3. The ShockWave is designed to give a great ride quality and to raise and lower the vehicle. **IT IS NOT MADE TO HOP OR JUMP!** If you want to hop or jump, hydraulics are a better choice. This abuse will result in bent piston rods, broken shock mounts, and destroyed bushings. **This is a non warrantable situation.**
4. Do not let the ShockWave bellows rub on anything. Failure will result. **This is a non warrantable situation.**
5. The ShockWave product has been field tested on numerous vehicles as well as subjected to many different stress tests to ensure that there are no leakage or durability problems. Failures have been nearly nonexistent unless abused as described above. If the Shockwave units are installed properly and are not abused, they will last many, many years. **ShockWave units that are returned with broken mounts, bent piston rods, destroyed bumpstops or bushings, or abrasions on the bellows will not be warrantied.**



350 S. St. Charles St. Jasper, In. 47546

Ph. 812.482.2932 Fax 812.634.6632

www.ridetech.com

Part # 11162899

67-69 GM "F" Body & 68-74 GM "X" Body Lower StrongArms

For Use w/ Shockwave or CoilOver

Components:

1	90000621	Driver side lower arm
1	90000622	Passenger side lower arm
2	90000898	Ball joint (includes boot, grease fitting, castle nut & cotter pin)
4	90000516	Inner bushing sleeve - .5" I.D. x .75" O.D. x 2.375" long
8	70010759	Delrin bushing half – 1.5" O.D.
4	90002062	Aluminum spacers – shock to lower arm

Hardware:

2	99501024	1/2"-13 x 3 1/4" Gr.5 bolt	Shockwave to lower arm
4	99501005	1/2"-13 x 3 1/2" Gr.5 bolt	Lower arm to frame
6	99502001	1/2"-13 Nylok Nut	Lower arm
2	99371010	3/8" x 5 1/2" USS bolt	Sway bar end link
4	99372002	3/8" USS Nylok Nut	Sway bar end link & Steering Stop
2	99371005	3/8" x 1 1/4" USS bolt	Steering stop

STRONG ARMS™

by Air Ride Technologies

Installation Instructions



1. After removing the factory lower control arm, clean the bushing mounting surfaces on the frame.
2. Fasten the lower arm to the frame with the $\frac{1}{2}$ " x $3 \frac{1}{2}$ " bolts and Nylok nuts supplied.

Note: On some cars the frame brackets may be pinched and will need to be spread back apart to allow bushing to slide in.

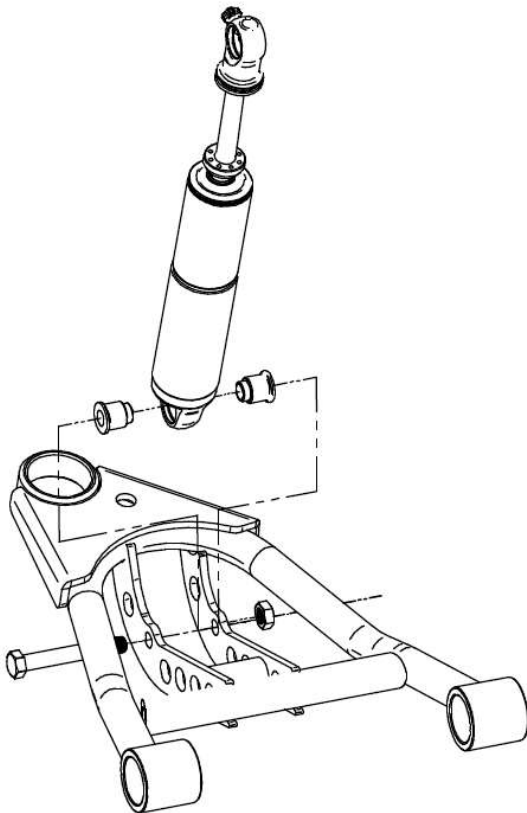

3. Swing the lower StrongArm up to the Shockwave and secure with the $\frac{1}{2}$ " x $3 \frac{1}{4}$ " bolt and Nylok nut, an aluminum spacer must be installed on each side of the bearing.
4. Slide the ball joint boot over the stud, then push the stud up through the spindle. Secure w/ the new castle nut and cotter pin supplied.
5. Grease the ball joints.
6. The Delrin Bushings are self-lubricating, no grease is required.



7. Screw a 3/8" x 1 1/4" bolt and nut into the hole in the side of the lower arm. This will act as an adjustable steering stop. After the wheel is install check wheel clearance all full lock and adjust as necessary.

8. If using factory style sway bar, shorten the sway bar end link spacer to 1 1/2" tall. New 3/8" x 5 1/2" bolts and Nylok nuts are supplied.

STRONG ARMS™

by Air Ride Technologies

Item #	Description	Qty.
1.	Passenger side arm	1
1.	Driver side arm	1
2.	Aluminum bearing spacer	4
3.	Ball joint	2
5.	Inner bushing sleeve	4
6.	1/2"-13 x 3 1/4" bolt	2
7.	1/2"-13 x 3 1/2" bolt	4
8.	1/2"-13 Nylok nut	6
9.	3/8"-16 x 1 1/4" bolt	2
10.	3/8"-16 Nylok nut	2
11.	Delrin Bushing Half	8

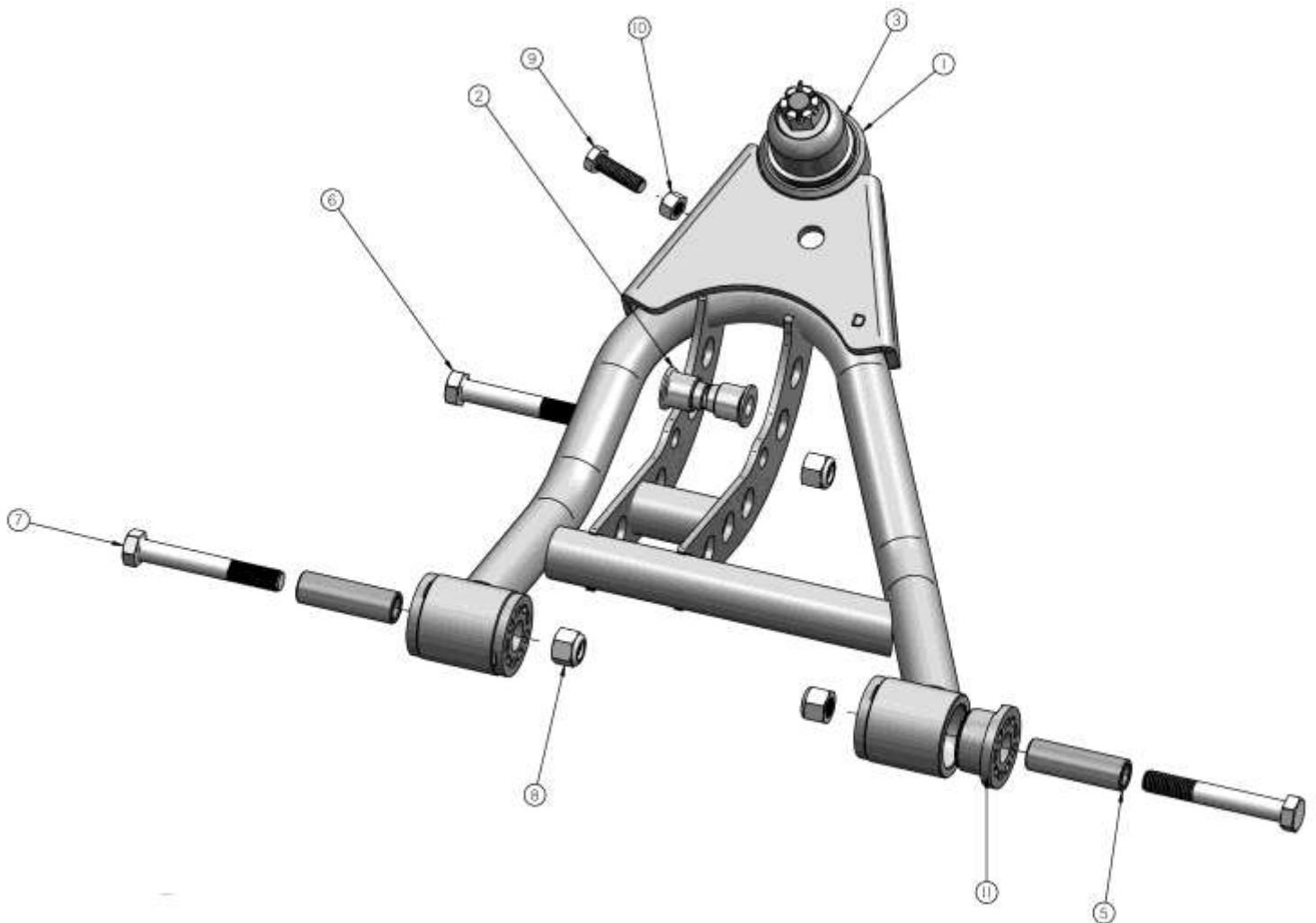



350 S. St. Charles St. Jasper, In. 47546
Ph. 812.482.2932 Fax 812.634.6632
www.ridetech.com

Part # 11163699
67-69 GM "F" Body & 68-74 GM "X" Body Upper StrongArms

Components:

1	90002390	Drivers side arm
1	90002391	Passenger side arm
2	90000908	Ball joint (includes boot, grease fitting, castle nut & cotter pin)
2	90000914	Caster Adjustable Cross shaft
2	70010826	Delrin Bushing – no ledge
2	70010827	Delrin Bushing – small ledge
4	70010759	Delrin Bushing – outer
4	70010883	Zero Offset Caster Slugs
2	90001083	Medium bump stop w/ hardware

Hardware:

4	99163001	Stainless Washer	Cross shaft to bushing
4	99622005	5/8" SAE crimp locking nuts	Cross shaft to bushing

Installation Instructions



Driver Side Top View

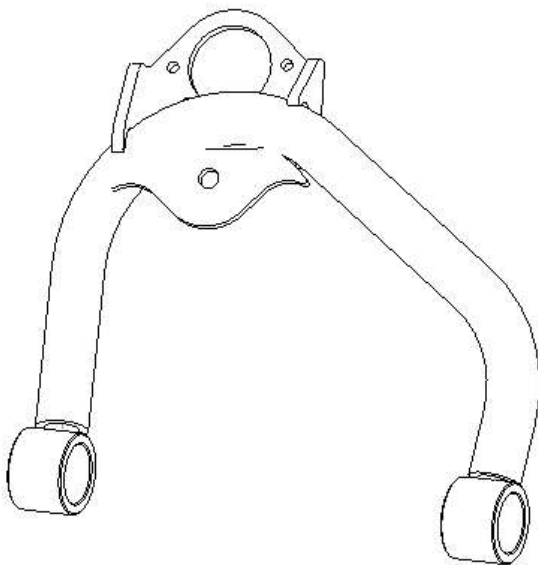

1. On some cars, to remove the upper control arm you must remove the bolts, which are pressed into the frame. We made this slide hammer adapter (a nut with a piece of angle iron welded to it) to aid in removing the bolts.

2. Fasten the upper arm to the frame using the factory hardware. Reinstall the current alignment shims, but **vehicle must be realigned**. This arm was designed with an extra 2 degrees of positive caster with the centered caster slugs. Additional caster slugs are available if more or less caster is desired. By changing the caster slugs you can achieve the caster setting you are wanting without having to run a lot of shims. Caster is explained of the next page.

3. Drop ball joint down through upper arm. Slide ball joint boot over stud, then place boot retainer over the boot. Clamp assembly tight w/ the hardware supplied.

4. Fasten the ball joint to the spindle w/ the new castle nut and cotter pin supplied.

5. Tighten the cross shaft nuts enough to create drag on the delrin bushings, the arm should still move.

6. Lubricate the ball joint w/ standard grease.

STRONG ARMS™

by Air Ride Technologies

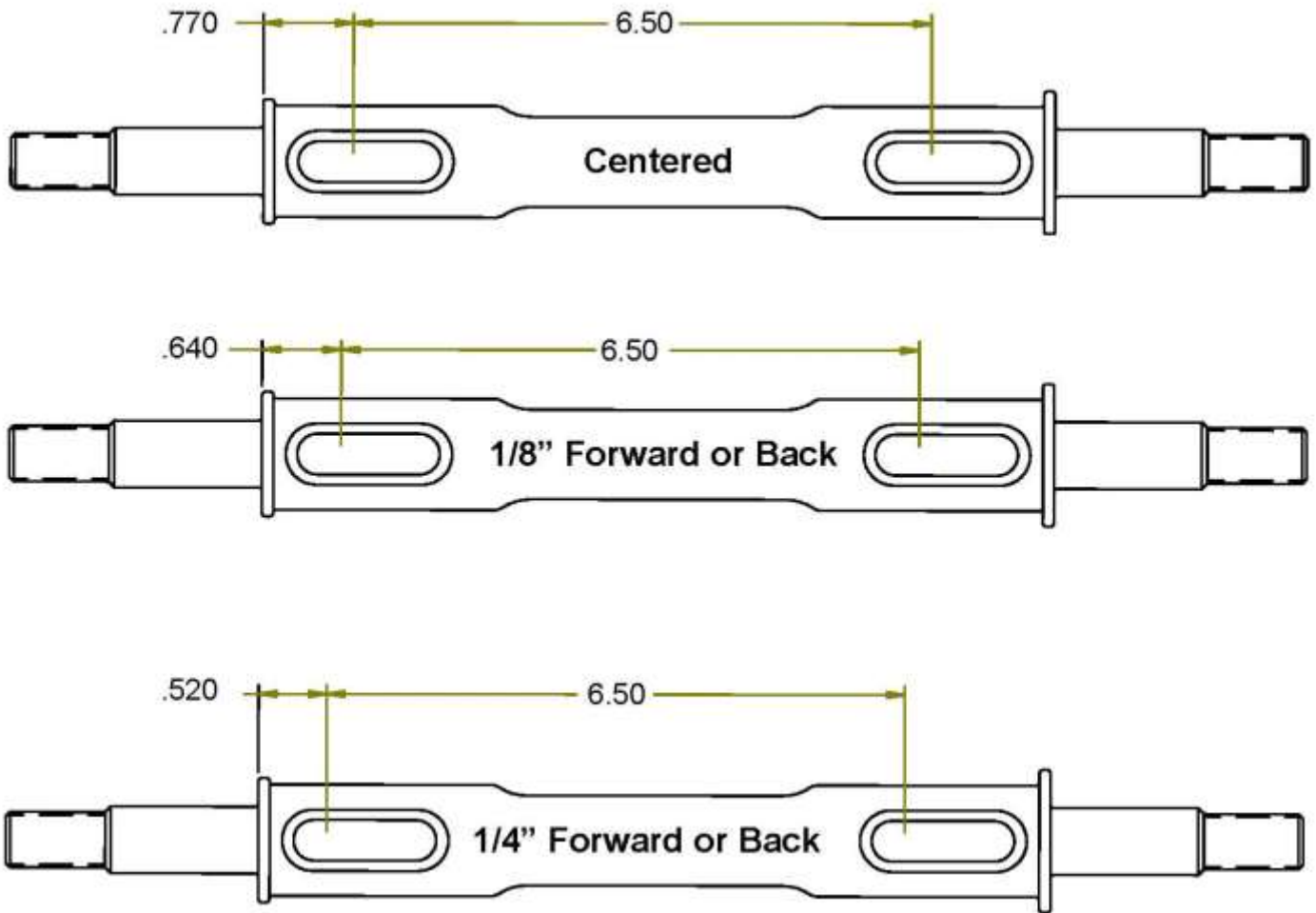

These Strong Arms come equipped with a changeable caster slug setup. This allows you to add or remove caster from the front suspension, if desired. The caster slugs that come in the kit are setup to put the control arm in the centered position, which is approximately 3 degrees of caster. The caster slugs allow you to add or remove caster without having to use a stack of shims. If more or less caster is desired, optional caster slugs can be purchased from your Ridetech dealer or Ridetech.

Caster Explained:

To understand caster you need to picture an imaginary line that runs through the upper ball joint and extends through the lower ball joint. From the side view the imaginary line will tilt forward or backward. The tilting of this imaginary line is defined as caster.

Caster is measured in degrees by using a caster camber gauge. If the imaginary line described above tilts towards the back of the car, at the top, then you will have positive caster. If the imaginary line tilts forward then you would have negative caster.

Positive caster provides the directional stability in your car. Too much positive caster will make the steering effort difficult. Power steering will allow you to run more positive caster. Negative caster requires less steering effort but can cause the car to wander down the highway.

STRONG ARMS™

by Air Ride Technologies

Item #	Description	Qty.
1.	Passenger side arm	1
1.	Driver side arm (Shown)	1
2.	Extension stop	2
3.	Ball joint	2
5.	3/8"-16 Nylok nut & washer	2
6.	1/4"-28 x 7/8" hex bolt	8
7.	1/4"-28 nut	8
8.	Inner Delrin bushing w/ledge	2
9.	Inner Delrin bushing no ledge	2
10.	Outer Delrin bushing	4
11.	Stainless washer	4
12.	5/8"-18 lock nut	4
13.	Caster Adjustable Cross shaft	2
14.	Caster Slug	4

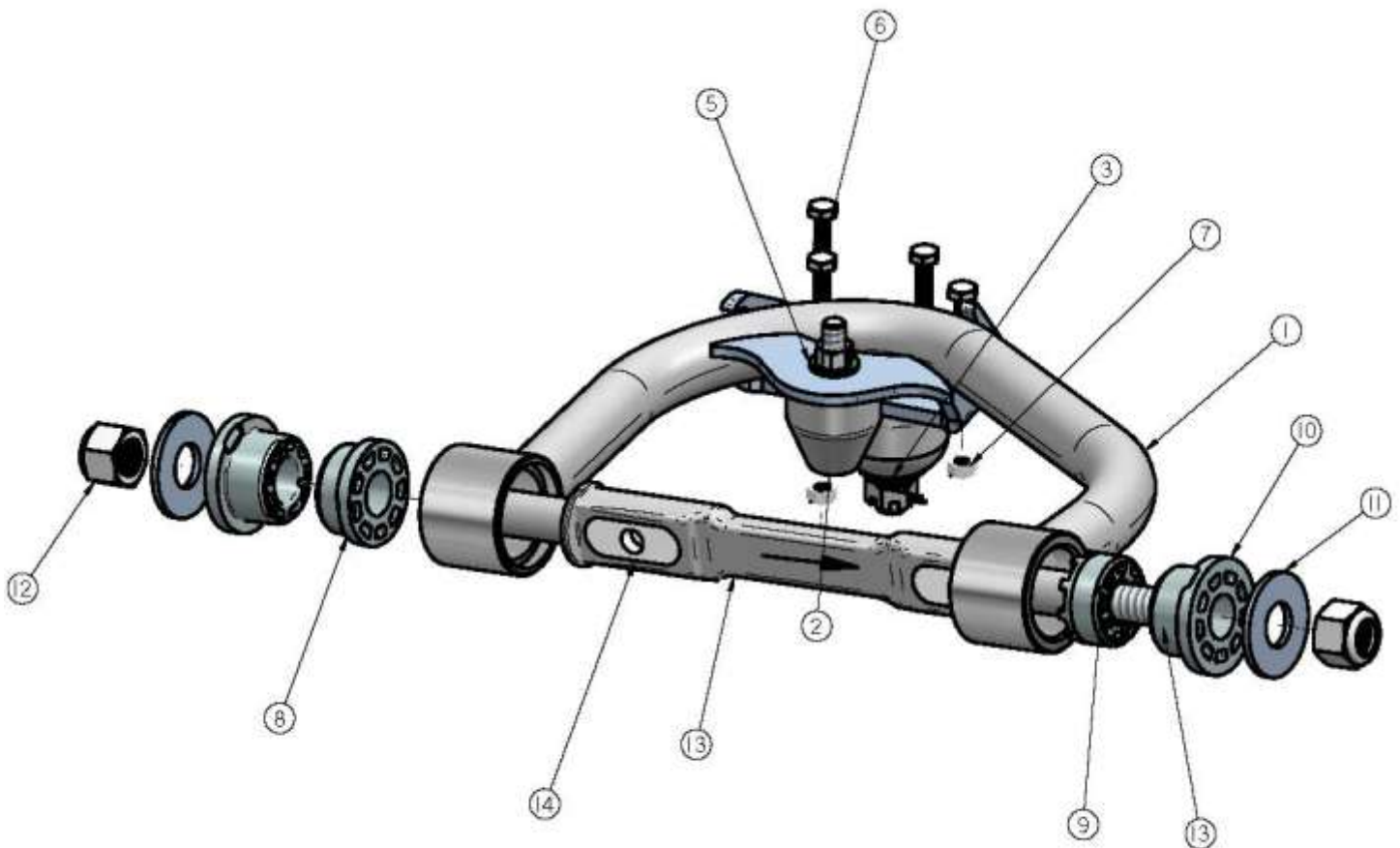



350 S. St. Charles St. Jasper, In. 47546

Ph. 812.482.2932 Fax 812.634.6632

www.ridetech.com

11009300 GM "A" & "F" Body Tall Spindles

2 Tall Spindles

Hardware:

Lower steering arm bolts

(4) 1/2NFX 2 1/2" flathead socket head bolts with Nyloc nuts

Lower caliper bracket bolts

(2) 1/2NFX 2" flathead socket head bolts with Nyloc nuts (Wilwood and Baer Brake kits)

(2) 1/2NFX 2" Grade 8 hex head bolts (use with stock stamped 1/2" thick caliper brackets)

INSTRUCTIONS FOR Ridetech Tall SPINDLES

These spindles will fit '67-69 Camaro, '64-'72 Chevelle, and '68-'74 Nova. They will provide a 2" drop, and are taller than stock to improve the car's cornering ability. The raised upper ball joint will cause the tires to lean into the corner, like a motorcycle, rather than outboard as the shorter stock spindles do. This camber action change also raises the roll center for less body roll, and transfer the car's center of gravity inboard in the turn as well. You will see an appreciable improvement in handling. Standard size anti sway bars will work well with those improvements, without the need for monster sway bars that can cause a harsh ride.

The spindles are modeled after stock disc brake spindles and will accept any disc brake set up designed for those. If your car came with drum brakes, be sure to swap to the appropriate disc brake master cylinder and valving. We have test fitted ECI, Wilwood, Baer, Aerospace, and stock GM kits. The only modification we discovered to be necessary was a small trim on the bottom of the stamped 1/4" steel caliper bracket that holds the caliper. It is an area that is not stressed and will not cause any loss of strength. There are variations among the various reproduction the shaft to be flipped in it's bushings for brackets, so the trim will be seen only on some of those.

Stock stamped control arms will accept these spindles, as will any aftermarket arms we have seen. Our own tubular control arms have the upper ball joint plates rotated slightly for better ball joint angles on lowered cars. We also set the ball joint 3/4" to the rear of the car to allow more aggressive positive caster settings, as well as to compensate for the normal forward rake seen on hot rods. The upper control arms shaft has a 3/16" offset, allowing the shaft to be rotated in it's bushings for a 3/8" net change in the upper arm's effective length. That design was pioneered by the MOOG company, as many stock autos suffer from a sagged cross member, making it difficult to obtain good alignment numbers. We suggest the alignment be done with 1/8" toe in, 1/2 degree positive camber, and 3 degrees positive caster with power steering, 2 degrees manual.

It is important to be sure you have the proper steering arms. Many cars were updated to disc brakes in the past by using disc brake and spindle assemblies from a donor car. However, the Chevelle steering arms are front steer, and the tie rod is roughly the same height as the lower ball joint. The Camaro and Nova arms are rear steer, with the outer tie rod end much lower than the ball joint. If the incorrect arms are used, the incorrect height tie rod end will cause major bump steer problems. Our testing of prototype versions of these spindles revealed that a small additional lowering of the mounting holes for the steering arms was necessary to remove the small amount of factory bumpsteer, and to account for the changes made by the taller spindle. We included that enhancement in the production version of your new dropped spindles.



Disassembly of the ball joints from the spindles can be eased by making the simple tool shown in the photo below. A pair of 1 ½" long bolts are threaded into a matching hex coupler. The ball joint cotter pins are removed, and the hex nuts loosened a couple turns. Place the tool between the ball joint studs, and turn a bolt to expand the tool, gently popping the ball joint studs loose. If your ball joint boots are torn, as often happens when a pickle fork is used to separate the ball joints, NAPA has replacements. The best way to remove the outer tie rod pivot is to loosen the hex nut, and then rap the steering arm boss with a hammer. Tie rod ends pullers are also available if you want to be more gentle on the parts. Do NOT hammer on the tie rod stud itself! Be sure to leave the shock absorber in place to control the spring and prevent it jumping out.

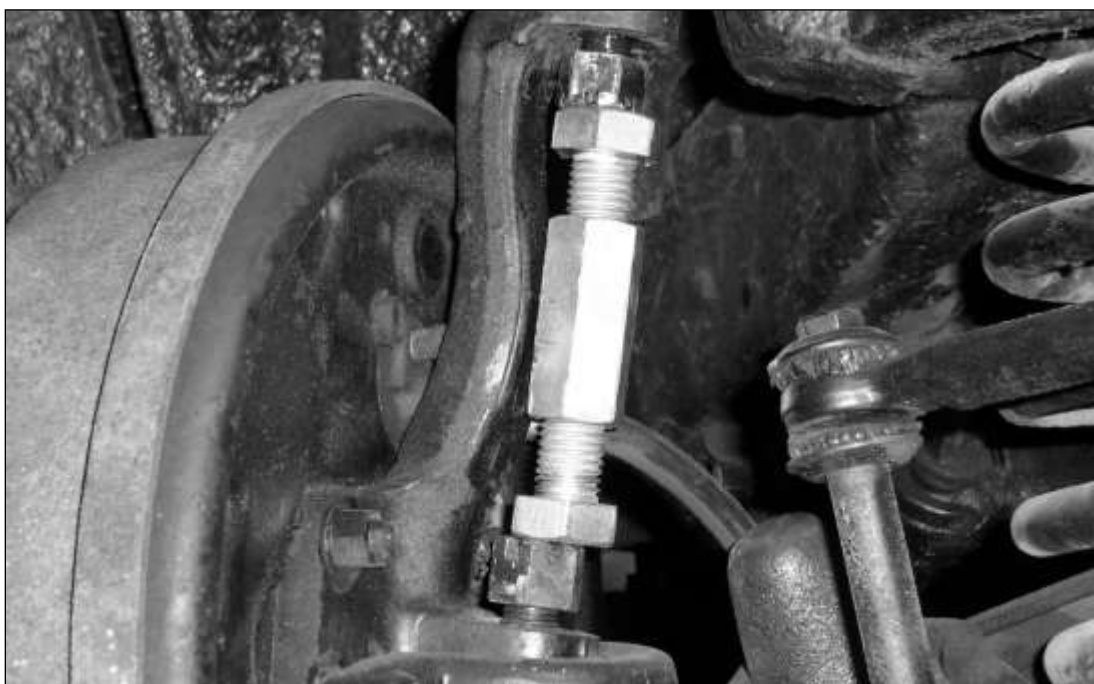



If you remove the calipers but leave the hoses attached, supporting them to avoid stressing the hoses, you won't even need to rebleed the brakes!

Reattach the new spindle, being sure to get the castle nuts tight, and install new cotter pins. Attach the steering arms into the lower holes in the spindles using the 4 supplied 1/2NFx2 1/2" long flathead bolts and Nyloc nuts supplied. The 1/2NFx 2" long flat head bolts and nyloc nuts we supply are for use with Wilwood and Baer brake kit lower bracket bolts. The 1/2NFx2" hex head bolts are used with stock caliper brackets. Reassemble your disc brakes as well. Now would be a good time to clean and grease the bearings.

BEFORE you try moving the car, pump the brakes to reset the pads to the rotors. Rebleed if necessary. Have the alignment shop set the car with 1/2 degree positive camber, 2-3 degrees positive caster, and 1/8" toe in. We're sure you'll be amazed at the difference in handling!



Note: If using a factory style stamped caliper bracket, the bracket may need to be trimmed. The dust shield may also need to be modified.

Part # 11267199 68-74 Nova Rear AirBar

Components:

1	90002077	Lower axle bracket - Driver
1	90002078	Lower axle bracket - Passenger
2	90001624	Lower billet Shockwave mount
2	90001617	Lower Shockwave stud
4	90002067	Aluminum spacer for stud
2	90000704	Tall Axle tabs (Outside)
2	90000705	Short Axle tabs (Inside)
1	90000703	Upper cradle assembly
2	90001001	Upper bars – TW 7.375" (C-C length 9.250")
1	90001029	Lower bar – WW 24.75" - Passenger side
1	90002328	Lower bar – WW 24.75" - Driver side
2	99250001	1/4"-28 straight grease fitting
2	90001589	Threaded Kevlar line Heim end
2	99752004	3/4"-16 jam nut – for rod end
4	90000552	Aluminum spacer for Heim end
4	90001942	Rubber bushings pressed into bars & rod ends
4	90001090	Poly bushing for lower bar
2	90000526	Lower bar bushing sleeve
2	70010694	Jig brackets for upper bar installation



Hardware Kit: (Part # 99010030)

2	1/2"-13 x 1 1/4" Gr. 5 bolt	Billet mount to axle bracket
2	1/2"-13 x 1 3/4" Gr. 5 bolt	Billet mount to axle bracket
4	1/2"-13 Nylok nut	Billet mount to axle bracket
6	5/8"-11 x 2 3/4" Gr.5 bolt	Bar ends
6	5/8"-11 Nylok jam nut	Bar ends
2	1/2"-13 x 2 1/4 Gr.5 bolt	Upper Shockwave mount
2	1/2"-13 Nylok jam nut	Upper Shockwave mount
16	3/8"-16 x 1" Thread forming bolt	Upper cradle assembly
16	3/8" SAE flat washer	Upper cradle assembly
8	7/16"-20 Nylok nut	Lower axle mount - U bolts
2	3/8"-16 x 3/4" Gr. 5 bolt	Upper bar installation jig
2	3/8"-16 nut	Upper bar installation jig

AirBAR[®]

by Air Ride Technologies

1. Raise the vehicle to a safe and comfortable working height. Use jack stands to support the vehicle with the suspension hanging freely.
2. Support the axle and remove the bump stops, leaf springs, shocks and tail pipes. Refer to the factory service manual for proper disassemble procedures. Keep the factory upper shock bolts, bump stop bolts, U-bolts, and front leaf spring mount and bolts.



3. One more thing needs to be removed before starting the assembly; it's the pinion snubber and mount. For a clean cut use a cut off wheel and smooth any burrs.



4. Lower the axle enough to slide the upper cradle into place. On most cars the location of the cradle will index off of the factory bump stop bolt hole. If your car has the bump stop beside the frame, slide the cradle forward until the front tube touches the body.

Note: The gas line may need to be moved.

5. A series of self-tapping 3/8" bolts are used to hold the cradle in place. First drill the holes with a 5/16" bit and then thread the bolts into the frame.



6. Install the large end of the lower bar (the long one) into the factory spring mount using the factory hardware. Do not over tighten this bolt; it should be snug. The bar is offset to the inside of the car for wheel and tire clearance.

7. This bushing is polyurethane and is lubricated at the factory with lithium grease, additional lubrication is not needed. Future lubrication can be done using any non-petroleum based lubricant.

8. Bolt the bar and mount back onto the car using the factory hardware.



9. The lower axle bracket will be fastened to the leaf spring pad using the factory U-bolts. It is offset to the inside of the car. New 7/16" nylocs are supplied.

10. Bolt the lower Shockwave mount to the lower holes of the axle bracket if you have a monoleaf car. If you have a multileaf car the bottom of the billet mount will be flush with the axle bracket.

11. Swing the lower bar up to the axle bracket and insert 5/8" x 2 3/4" bolt. The standard hole is the center hole like in the picture. Thread 5/8" Nylok onto the bolt but **do not tighten** yet.

12. This end of the bar as well as the upper bars are rubber and do not require lubrication.



13. Check the length of the upper bar; it should be 9 1/4" C-C. Bolt the axle tabs to the setting jig (**The setting jig is explained on the next page**). (Longer ears to the front) Then place the other end of the jig into the cradle. Both ends use a 5/8" x 2 3/4" and should not be fully tightened yet. For now just the let axle tabs sit on the axle.

14. Before welding these tabs to the axle you will need to center the axle and set pinion angle. We used a plum on the outside of the quarter panel to center the axle left to right. Setting the pinion angle is explained on the pinion angle page.

This must be done at ride height.

Upper Bar Installation Jig

- This jig has been supplied to aid in the installation of the upper 4 link bar. It can be temporarily used to properly align, locate and weld the tabs onto the axle. It will also ensure that the mounting bolts are parallel to the ground.
- Follow the diagram below to set the jig to the same length as the upper bar, use the 3/8" x 3/4" bolt and nuts to set the length.
- Position the axle at ride height. Center the axle left to right between the quarter panels. Set pinion angle.
- Bolt one end of the jig to the cradle using a 5/8" x 2 3/4" bolt.
- Using another 5/8" x 2 3/4" bolt, fasten the axle tabs to the other end. The tabs must be bolted to the **outside** of the jig. **Short tab goes to the inside with the long ear forward, the Tall Tab goes to the outside of the car with the long tab forward.**
- Swing the bar down letting the tabs rest onto the axle. Trim the brackets as necessary to minimize the gap to be welded.
- Check pinion angle, ride height and axle center. Tack-weld the tabs in place.
- Remove jig and install upper bar.
- Repeat this process for the other side.
- Recheck pinion angle, ride height and axle center. (Sound familiar?)
- After the tabs have been tack welded on both sides, remove the upper bars to avoid melting the rubber bushings. Let the axle drop down for better access to the tabs. Lay 1" welds on the inside and outside of the tabs. Skip around from one side to the other to avoid overheating the tube.

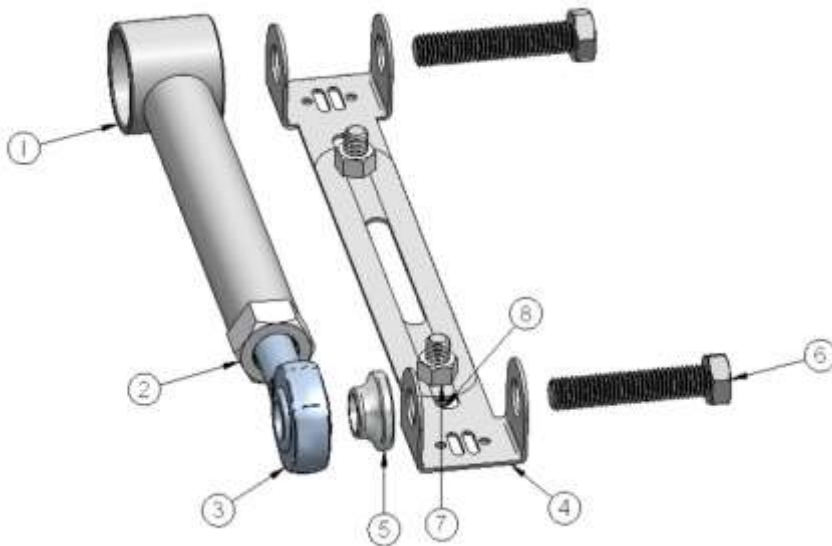

Item #	Description
1.	Upper bar
2.	3/4"-16 jam nut
3.	Heim end
4.	Alignment jig
5.	Aluminum spacer
6.	5/8"-11 x 2 3/4" bolt
7.	3/8"-16 nut
8.	3/8"-16 x 3/4" bolt



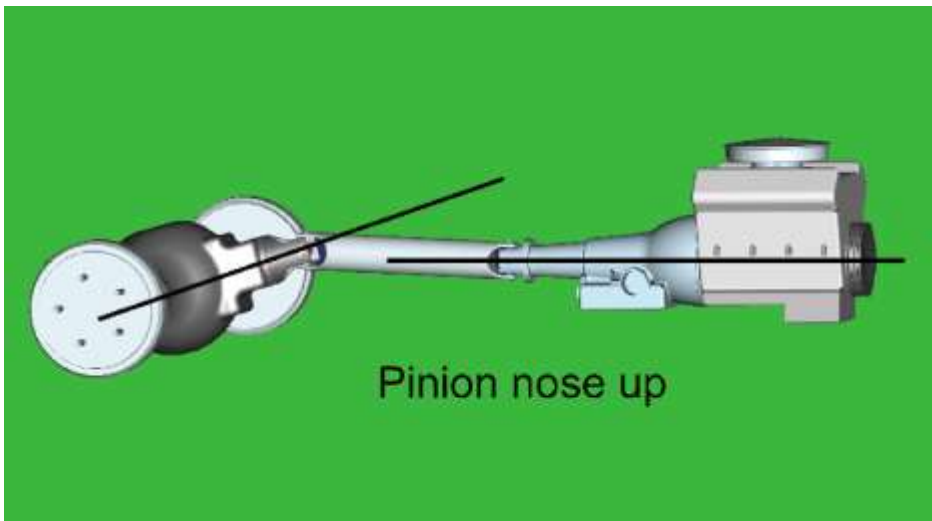
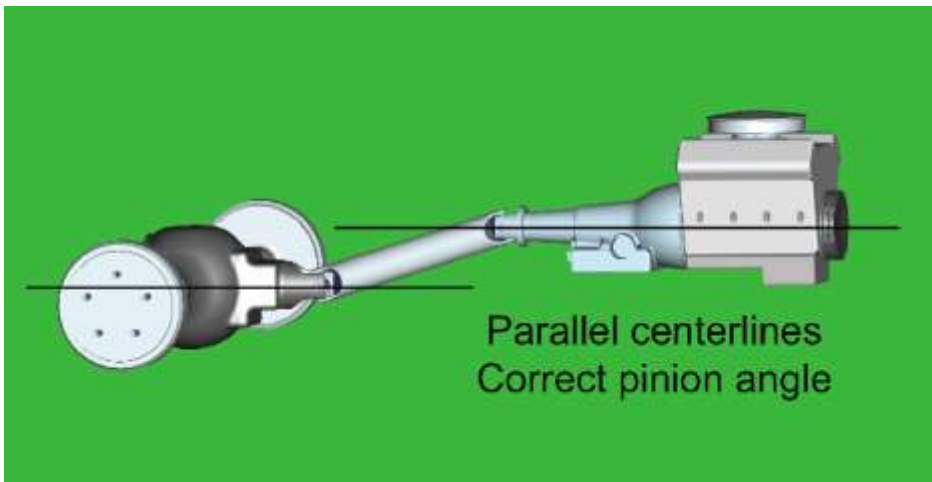
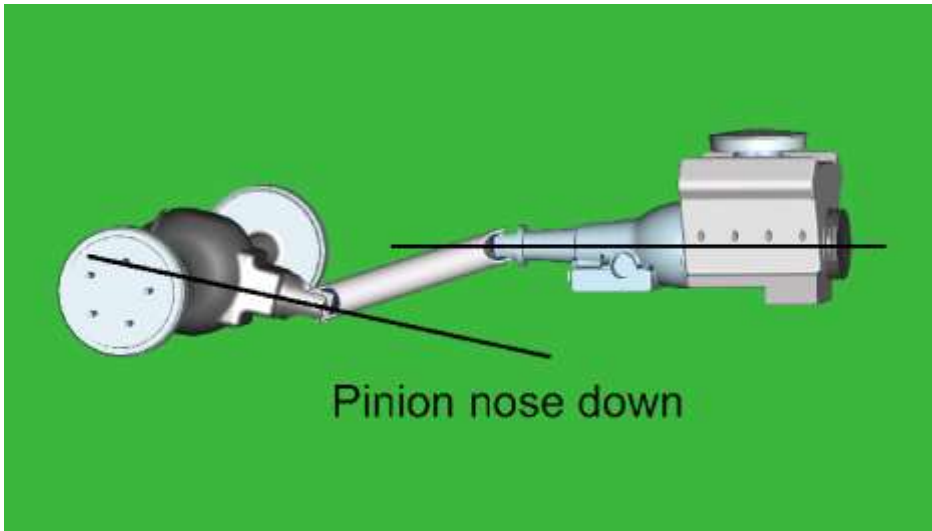

15. How do you set the pinion angle? On a single-piece shaft you want to set it up where a line drawn through the center of the engine crankshaft or output shaft of the transmission and a line drawn through the center of the pinion are parallel to each other but not the same line.

A simple way to do this is to place a digital angle finder or dial level on the front face of the lower engine pulley or harmonic balancer. This will give you a reading that is 90 degrees to the crank or output shaft unless you have real problems with your balancer. At the other end, you can place the same level or angle finder against the front face of the pinion yoke that is also at 90 degrees to the centerline. If you rotate the yoke up or down so both angles match, you have perfect alignment.

Road testing will tell you if you have it right. If you accelerate and you get or increase a vibration, then the pinion yoke is too HIGH. Rotate it downward in small increments of a degree or two until the problem goes away. If you get or increase a vibration when decelerating, then the pinion yoke is too LOW. Rotate it upward to correct it.



16. One helpful trick to help maintain ride height and pinion angle while adjusting is to tack weld a spacer between the axle and the outside of the frame as shown in the picture. This spacer should be 8 3/8" tall giving the Shockwave an eye-to-eye measurement of 14 1/2" to 15".

17. After double-checking pinion angle, ride height, and axle center the tabs can be tack welded. Remove the bar to avoid frying the bushing and finish welding the tabs to the axle.



18. Apply thread sealant to the air fitting and screw it into the Shockwave.

19. Install the Shockwaves using the 1/2" x 2 1/4" bolt and nyloc on top and the 7/16" nyloc on the lower stud mount. There should be a washer on either side of the Shockwave on the stud and none on the upper mount.

20. You can now go back and snug all of the bar end nylocs. This must be done at ride height.

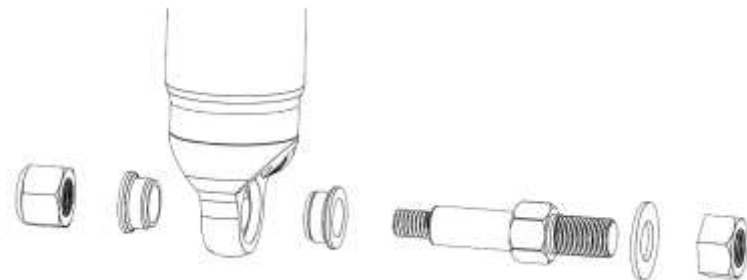

21. You can now remove the spacer from between the axle and frame.

22. The installation is complete but you want to check clearance of the brake lines, parking brake cables, vent tubes and exhaust. For the exhaust you can either install a turndown or reroute the exhaust under the axle.

23. Ride height is 14.5", around 70psi.



350 S. St. Charles St. Jasper, In. 47546

Ph. 812.482.2932 Fax 812.634.6632

www.ridetech.com

Should I weld my AirBar 4 link assembly in?

Since we get this question quite often, it deserves a proper explanation.

The AirBar has been designed for bolt-in installation. We have paid special attention to interfacing with key structural areas of each vehicle, fastening bracketry in at least two planes to properly distribute load paths, and to using appropriate fasteners that roll, rather than cut, threads into the vehicle structure.

Having said that, you could potentially encounter a vehicle that has rust or collision damage in these areas. Or maybe you intend to consistently place the vehicle in severe racing applications with sticky racing slicks and high speed corners. In these cases it is perfectly acceptable to weld the AirBar components into your vehicle. Even in these severe cases we recommend that you install the entire AirBar assembly first [including the fasteners], and then use short 1" long tack welds to secure your installation. Remember that the vehicle structure metal is typically much thinner [.060"-.120"] than the .188" thick AirBar brackets. If you burn through the vehicle sheet metal structure you may end up with an installation that is weaker than before you tried to weld it.

The other reason to weld in your AirBar assembly is...you simply want to. You're a welding kind of guy...that's the way you've always done it...you have the skills and equipment to do it. In that case...weld away with our blessing!



350 S. St. Charles St. Jasper, In. 47546

Ph. 812.482.2932 Fax 812.634.6632

www.ridetech.com

Part # 21150701

7000 HQ Series Shockwaves

Single Adj. - 4" Diameter - 5" Stroke - .625" Bearing/.625" Bearing

2	24159999	5" stroke HQ Series shock
2	24090799	7000 series Shockwave bellow assembly
2	90002024	Short eye mount (1.5" tall)
4	90001994	.625" I.D. bearing
8	90001995	Snap ring
4	90002043	1/2" Aluminum Spacers
2	31954201	1/4" npt x 1/4" tube swivel elbow fitting

SHOCKWave[®]

by Air Ride Technologies

7000 Series Shockwave

Use these
spacers when
mounting on 5/8"
bolt.



Compressed Height	11.5"
Ride Height	14.5"
Extended Height	16.5"

Use these spacers
when mounting on
1/2" bolt.



The care and feeding of your new ShockWaves

1. Although the ShockWave has an internal bumpstop, **DO NOT DRIVE THE VEHICLE DEFLATED RESTING ON THIS BUMPSTOP. DAMAGE WILL RESULT.** The internal bumpstop will be damaged, the shock bushings will be damaged, and the vehicle shock mounting points may be damaged to the point of failure. **This is a non warrantable situation.**
2. Do not drive the vehicle overinflated or “topped out”. Over a period of time the shock valving will be damaged, possibly to the point of failure. **This is a non warrantable situation!** If you need to raise your vehicle higher than the ShockWave allows, you will need a longer unit.
3. The ShockWave is designed to give a great ride quality and to raise and lower the vehicle. **IT IS NOT MADE TO HOP OR JUMP!** If you want to hop or jump, hydraulics are a better choice. This abuse will result in bent piston rods, broken shock mounts, and destroyed bushings. **This is a non warrantable situation.**
4. Do not let the ShockWave bellows rub on anything. Failure will result. **This is a non warrantable situation.**
5. The ShockWave product has been field tested on numerous vehicles as well as subjected to many different stress tests to ensure that there are no leakage or durability problems. Failures have been nearly nonexistent unless abused as described above. If the Shockwave units are installed properly and are not abused, they will last many, many years. **ShockWave units that are returned with broken mounts, bent piston rods, destroyed bumpstops or bushings, or abrasions on the bellows will not be warrantied.**



Part # 30334100 - 3 Gallon LevelPro Compressor System

Recommended Tools

Components:

2	31920020	Thomas 319 Compressor
1	31934001	4 way RidePro air valve assembly
1	31913100	3 gallon Aluminum tank
5	31988150	Air pressure sensor
1	31398001	RidePro LevelPro ECU
1	31398002	RidePro LevelPro Display
2	99064002	6-32 x 3/8" Phillips pan head screw for display
1	82010000	Installation Guide

Wiring & Hardware:

1	31900031	Display Harness
1	31900020	Air valve wiring harness
1	31900006	Air pressure sensor wiring harness
1	31900048	Main power / compressor harness
2	90001924	Fuse holder
2	90001922	20 Amp fuse
6	99104001	10-24 x 1" phillips screw
6	99102002	10-24 Nylok nut
6	99103001	#10 SAE flat washer
2	90001913	12-10 Gauge Butt Connector
2	90001916	#10 x 5/16" Ring Terminal

Airlines & Fittings:

2	31940002	1/4" DOT airline – 30' roll
6	31954201	1/4" npt x 1/4" tube elbow fitting - air springs / tank
7	31954000	1/4" npt x 1/4" tube straight fitting - air valve
2	31952150	1/8" npt female x 1/4" tube straight fitting - compressor
2	31957003	1/8" npt nipple (install between FIT2150 & compressor)
3	31957004	1/4" npt plug - plug extra supply port
1	31954400	1/4" air line tee- compressors to check valve fitting
1	31959301	Check Valve- SCREWS INTO TANK FOR COMPRESSOR LINE



THE CHECK VALVE SUPPLIED SCREWS INTO THE AIR TANK WITH AN AIR FITTING THREADING INTO IT. THE COMPRESSOR LINES WILL FEED INTO THE CHECK VALVE.

