



350 S. St. Charles St. Jasper, In. 47546

Ph. 812.482.2932 Fax 812.634.6632

www.ridetech.com

Part # 11020299
55-57 Chevy Level 2 Air Suspension Package
One Piece Frame

Front Components:

1	11013001	HQ Series Front Shockwaves
1	11012899	Front Lower StrongArms
1	11013699	Front Upper StrongArms

Rear Components:

1	11027199	Rear AirBar 4 Link
1	21140701	HQ Series Rear Shockwaves

Compressor System:

1	30334100	5 gallon LevelPro Compressor Kit
---	----------	----------------------------------



350 S. St. Charles St. Jasper, In. 47546
Ph. 812.482.2932 Fax 812.634.6632

www.ridetech.com

Part #11013001
55-57 Chevy Car Front RQ Series ShockWaves
For Use w/ Lower StrongArms

ShockWave Assembly:

2	24090399	104mm Master Series rolling sleeve assembly
2	24149999	4" stroke HQ Series shock
2	70008913	Locking ring
2	90001994	.625" I.D. bearing
4	90001995	Bearing snap ring
2	90009988	Short Delrin stud top – 2"

Components:

2	90002312	Short Delrin stud top base – 2"
2	90001902	Aluminum cap for Delrin ball
2	90001903	Delrin ball upper half
2	90001904	Delrin ball lower half
2	31954201	¼"npt x ¼" tube swivel elbows

Hardware:

2	99562003	9/16" SAE Nylok jam nut	Stud top hardware
---	----------	-------------------------	-------------------

SHOCKwave[®]

by Air Ride Technologies

Installation Instructions

1. Raise and support vehicle at a safe, comfortable working height. Let the front suspension hang freely.
2. Remove the coil spring and shock absorber. Refer to a factory service manual for proper disassembly procedure.

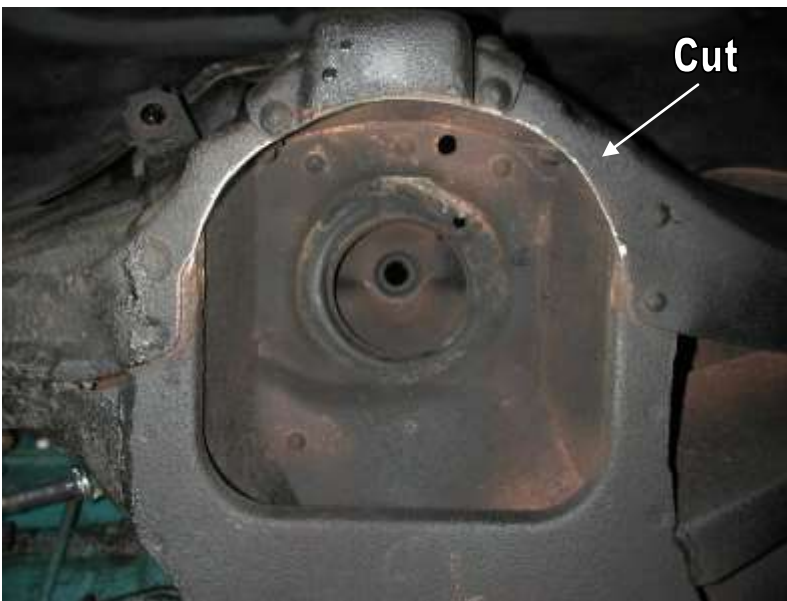

3. For air spring clearance some trimming must be done on the outer lip of the coil spring pocket. This is what it should look like after cutting.

4. This is best done with a cut off wheel or plasma cutter. Grind all cuts smooth when finished.

Allowing the shockwave will rub will result in failure, this is not a warrantable situation.



5. The domed portion of the Shockwave will hit the coil spring retainer. This lip must be removed.

6. The factory upper bushing cup must also be removed.

7. Apply thread sealant to a 90 degree air fitting and screw it into the top of the Shockwaves. The fitting location can be rotated by twisting the bellow while holding the shock body.



8. Place the Shockwave up into the coil spring pocket with the stud protruding through the factory shock hole. See diagram below. The factory shock hole may need to be drilled out to $\frac{3}{4}$ ".

9. Fasten the Shockwave to the factory lower control arm using the $\frac{1}{2}$ " x $3\frac{1}{4}$ " bolt, Nylok nut & aluminum spacers supplied w/ the StrongArms.

10. Ride height will be around 90-100 psi, but will vary to driver preference and vehicle weight.

1. Stud top aluminum base
2. Delrin ball lower half
3. Delrin ball upper half
4. Aluminum cap
5. $\frac{9}{16}$ " SAE Nylok jam nut
6. Threaded stud (screwed onto shock shaft)
7. Rebound adjusting knob
8. Screw

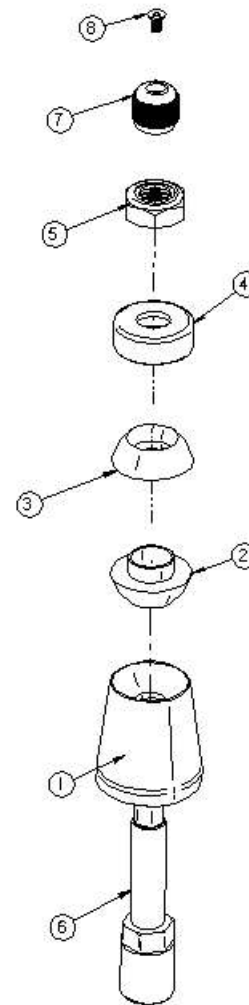



350 S. St. Charles St. Jasper, In. 47546
Ph. 812.482.2932 Fax 812.634.6632
www.ridetech.com

Part # 11012899
55-57 Chevy Car Lower StrongArms
For Use with Shockwaves or CoilOvers

Components:

- | | | |
|---|----------|----------------------------------------------------------------|
| 1 | 90000561 | Driver side lower control arm |
| 1 | 90000562 | Passenger side lower control arm |
| 2 | 90000916 | Lower ball joint (includes boots, castle nuts and cotter pins) |
| 4 | 90000906 | Lower control arm bushing |
| 4 | 90002062 | Aluminum spacers for Shockwaves |

Hardware:

- | | | | |
|---|----------|-------------------------|------------------------|
| 2 | 99501024 | ½"-13 x 3 ¼" Gr. 5 bolt | ShockWave to lower arm |
| 2 | 99502001 | ½"-13 Nylok nut | ShockWave to lower arm |

Installation Instructions

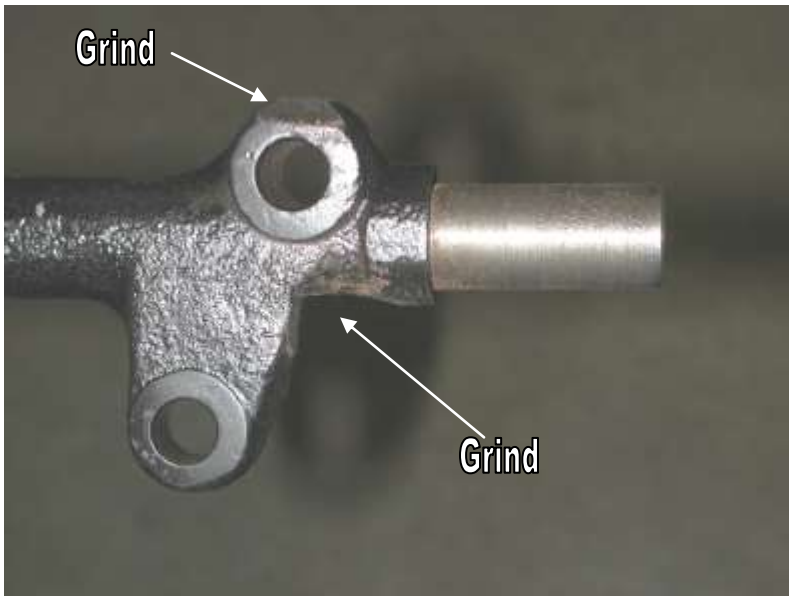

1. Remove factory cross shafts from lower arm and install the factory cross shaft onto the lower StrongArm using the factory hardware. Some grinding must be done on the cross shaft to be able to slide it into the StrongArm. Replacement bushings are provided.

Note: There is a driver and passenger side lower cross shaft. The extended length of the shaft should go to the front of the vehicle.



2. Install the ball joints in the lower arm pointing down.

3. Bolt the lower StrongArm to the car using the oem bolts. Note that the sway bar mount will face toward the front of the vehicle.

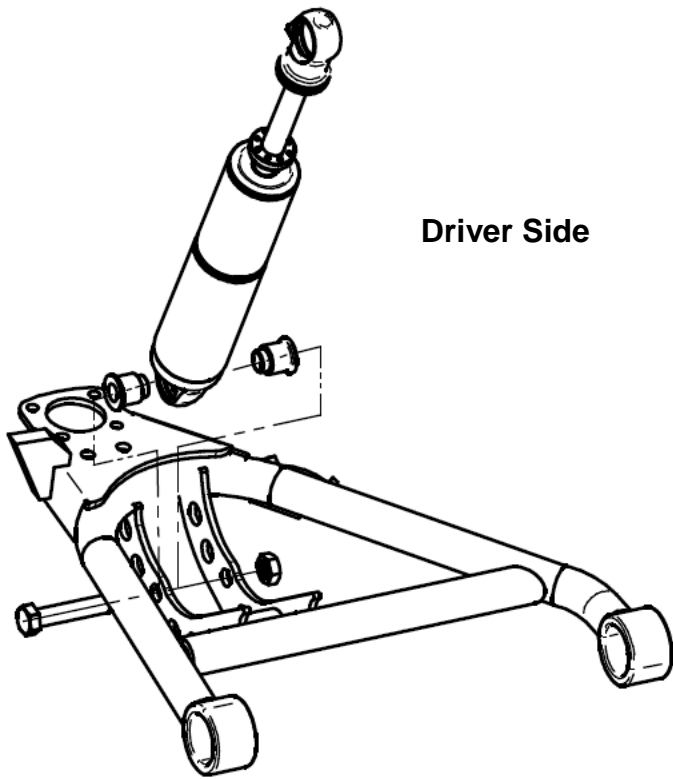

4. Bolt the Shockwave or CoilOver to the lower arm using the supplied 1/2" x 3 1/4" bolt and Nylok. An aluminum spacer on both sides of the eye will center the Shockwave.

Note: There are holes on the lower arm near the ball joint to mount the factory bump stop. Although, it is not needed unless you are having tire clearance issues.

5. Slide the ball joint through the spindle and secure w/ castle nut and cotter pin.



6. Grease the ball joints.

7. Double check air spring clearance through full suspension travel. If any part of the Shockwave touches the frame at anytime it will damage the unit. **This is not a warrantable situation.**

STRONG ARMS™

by Air Ride Technologies

Item #	Description	Qty.
1.	Passenger side arm	1
1.	Driver side arm	1
2.	Aluminum bearing spacer	4
3.	1/2"-13 x 3 1/4" bolt	2
4.	1/2"-13 Nylok nut	2
5.	Cross shaft bushing	4
6.	Ball joint	2
7.	5/16"-24 nut	8
8.	5/16"-24 x 3/4" bolt	8

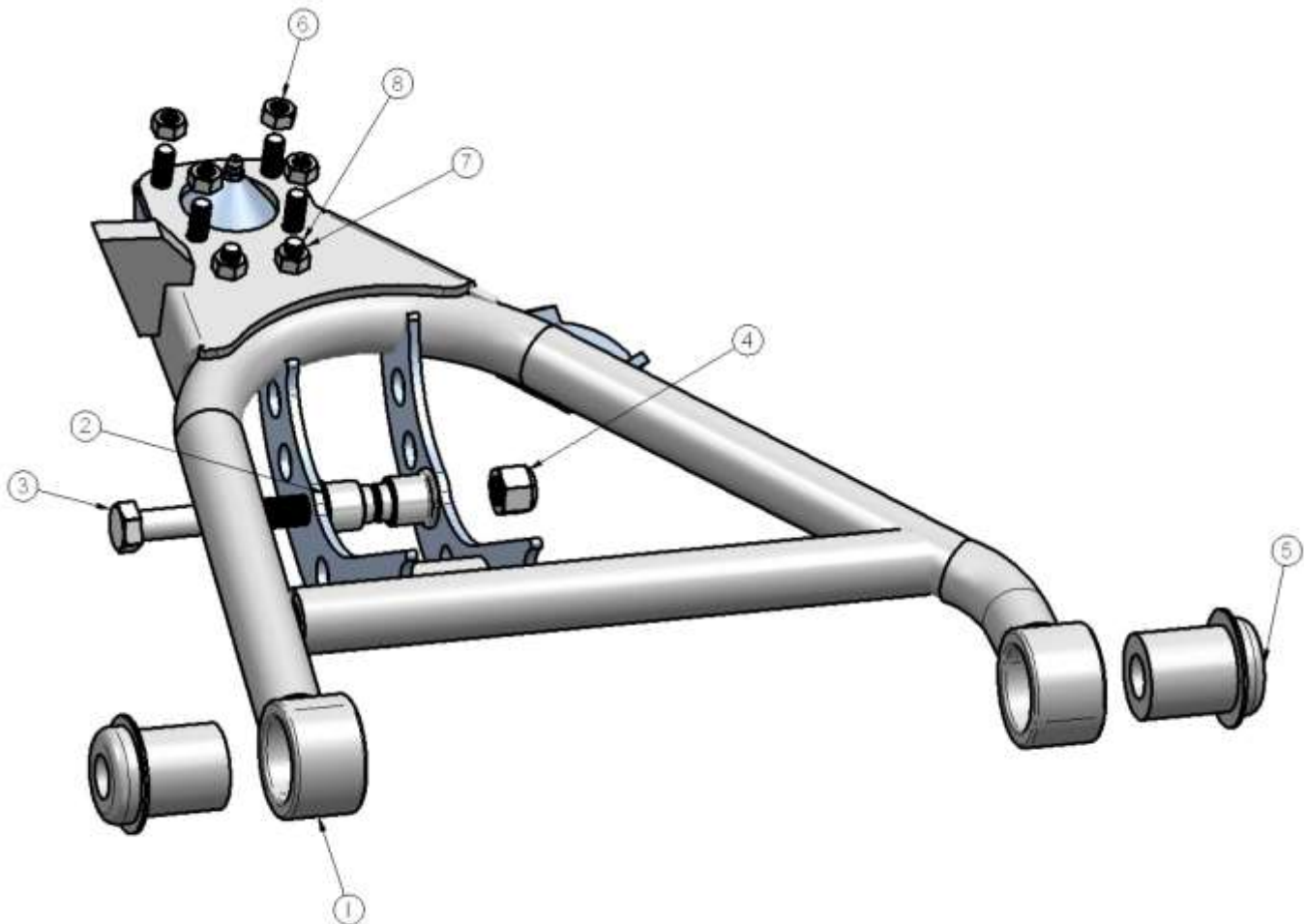



350 S. St. Charles St. Jasper, In. 47546
Ph. 812.482.2932 Fax 812.634.6632
www.ridetech.com

Part Number 11013699
55-57 Chevy Upper StrongArms

Components:

1	90000541	Driver side upper arm
1	90000542	Passenger side upper arm
2	90000905	Ball joint (includes boot, grease fitting, castle nut & cotter pin)
4	90000907	Cross shaft bushing
4	90000543	Upper cross shaft large sleeve
4	90000544	Upper cross shaft small sleeve

Hardware:

4	99371015	3/8"-24 x 1 1/2" bolts	Upper cross shaft
4	99373005	3/8" lock washers	Upper cross shaft

Installation Instructions



1. Remove the upper control arm and cross shaft. The factory cross shaft will be reused.
2. Place the larger sleeve over the end of the upper cross shaft, slide the cross shaft through the StrongArm. Then press the bushing over the shaft. Insert the smaller sleeve inside the bushing and tighten the assembly with the 3/8" - 24 x 1 1/2" bolts.
3. Install the ball joint into the upper StrongArm also facing down.



4. Bolt the upper StrongArm to the frame and spindle using the factory frame bolts.
5. The upper control arm bump stop is reused.
6. Grease the ball joints.

55-57 Chevy Upper StrongArm

Item #	Description	Qty.
1.	Passenger side arm	1
1.	Driver side arm	1
2.	Ball Joint	2
3.	Upper Cross shaft Large Sleeve	4
4.	Cross shaft bushing	4
5.	Upper Cross shaft Small Sleeve	4

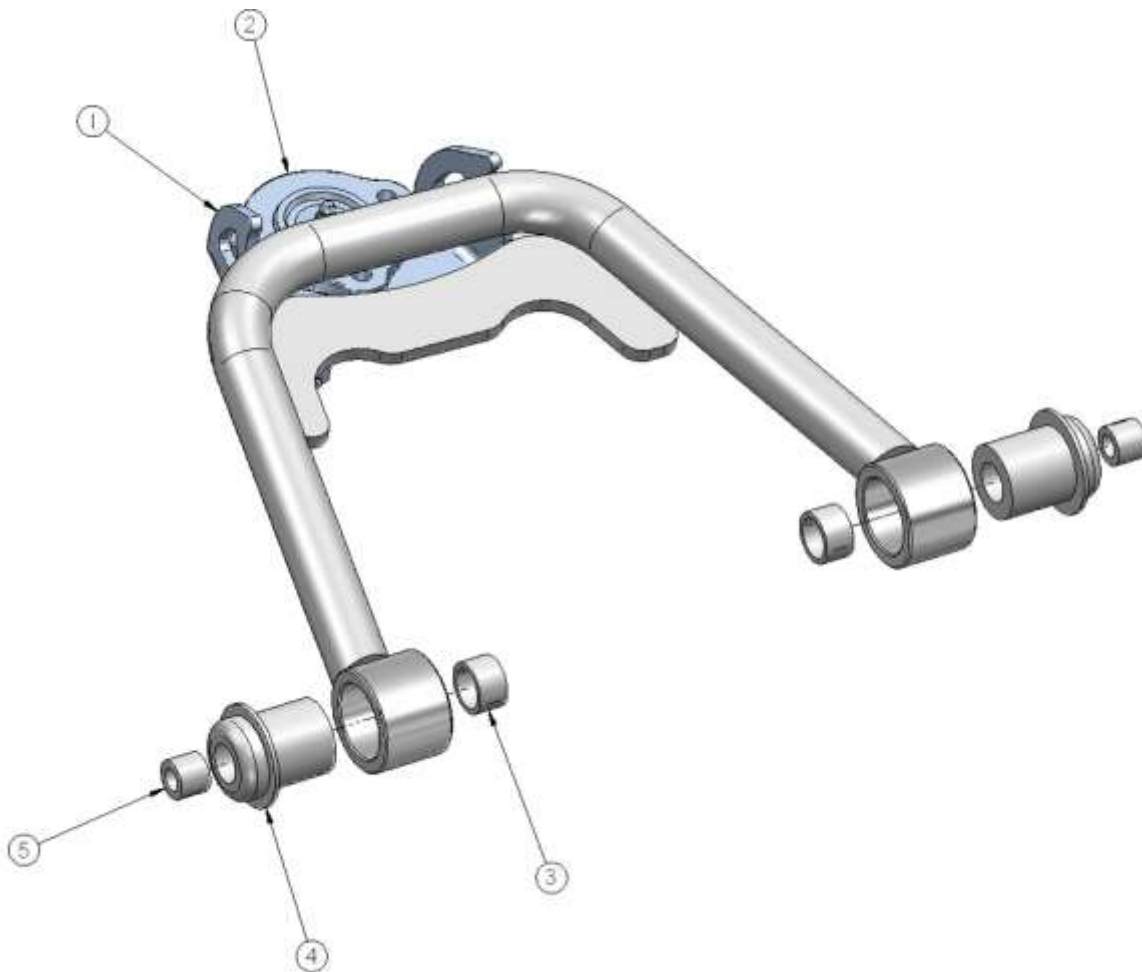



350 S. St. Charles St. Jasper, In. 47546
Ph. 812.482.2932 Fax 812.634.6632
www.ridetech.com

Part # 21140701
7000 HQ Series Shockwaves
HQ Series. - 4" Diameter - 4" Stroke - .625" Bearing/.625" Bearing

2	24149999	4" stroke HQ Series shock
2	24090799	7000 series Shockwave bellow assembly
2	70008913	Locking ring
2	90002024	Short eye mount (1.7" tall)
4	90001994	.625" I.D. bearing
8	90001995	Snap ring
4	90002043	Bearing spacer - .5" I.D.
2	31954201	1/4" npt x 1/4" tube swivel elbow fitting

SHOCKWave[®]

by Air Ride Technologies

7000 Series Shockwave

Use these
spacers when
mounting on 5/8"
bolt.



Compressed Height	10.6"
Ride Height	13"
Extended Height	14.6"

Use these spacers
when mounting on
1/2" bolt.

Shock adjustment 101- Single Adjustable

Rebound Adjustment:

How to adjust your new shocks.

The rebound adjustment knob is located on the top of the shock absorber protruding from the eyelet.

You must first begin at the ZERO setting, then set the shock to a soft setting of 20.



-Begin with the shocks adjusted to the ZERO rebound position (full stiff). Do this by rotating the rebound adjuster knob clockwise until it stops.



-Now turn the rebound adjuster knob counter clock wise 20 clicks. This sets the shock at 20. (settings 21-24 are typically too soft for street use).

Take the vehicle for a test drive.



-if you are satisfied with the ride quality, do not do anything, you are set!



-if the ride quality is too soft increase the damping effect by rotating the rebound knob clock wise 3 clicks.

Take the vehicle for another test drive.



if the vehicle is too soft increase the damping effect by rotating the rebound knob clock wise 3 additional clicks.



-If the vehicle is too stiff rotate the rebound adjustment knob counter clock wise 2 clicks and you are set!

Take the vehicle for another test drive and repeat the above steps until the ride quality is satisfactory.

Note:

One end of the vehicle will likely reach the desired setting before the other end. If this happens stop adjusting the satisfied end and keep adjusting the unsatisfied end until the overall ride quality is satisfactory.

The care and feeding of your new ShockWaves

1. Although the ShockWave has an internal bumpstop, **DO NOT DRIVE THE VEHICLE DEFLATED RESTING ON THIS BUMPSTOP. DAMAGE WILL RESULT.** The internal bumpstop will be damaged, the shock bushings will be damaged, and the vehicle shock mounting points may be damaged to the point of failure. **This is a non warrantable situation.**
2. Do not drive the vehicle overinflated or "topped out". Over a period of time the shock valving will be damaged, possibly to the point of failure. **This is a non warrantable situation!** If you need to raise your vehicle higher than the ShockWave allows, you will need a longer unit.
3. The ShockWave is designed to give a great ride quality and to raise and lower the vehicle. **IT IS NOT MADE TO HOP OR JUMP!** If you want to hop or jump, hydraulics are a better choice. This abuse will result in bent piston rods, broken shock mounts, and destroyed bushings. **This is a non warrantable situation.**
3. Do not let the ShockWave bellows rub on anything. Failure will result. **This is a non warrantable situation.**
4. The ShockWave product has been field tested on numerous vehicles as well as subjected to many different stress tests to ensure that there are no leakage or durability problems. Failures have been nearly nonexistent unless abused as described above. If the Shockwave units are installed properly and are not abused, they will last many, many years. **ShockWave units that are returned with broken mounts, bent piston rods, destroyed bumpstops or bushings, or abrasions on the bellows will not be warrantied.**



Part # 30334100 - 3 Gallon LevelPro Compressor System

Recommended Tools



Components:

2	31920020	Thomas 319 Compressor
1	31934001	4 way RidePro air valve assembly
1	31913100	3 gallon Aluminum tank
5	31988150	Air pressure sensor
1	31398001	RidePro LevelPro ECU
1	31398002	RidePro LevelPro Display
2	99064002	6-32 x 3/8" Phillips pan head screw for display
1	82010000	Installation Guide

Wiring & Hardware:

1	31900031	Display Harness
1	31900020	Air valve wiring harness
1	31900006	Air pressure sensor wiring harness
1	31900048	Main power / compressor harness
2	90001924	Fuse holder
2	90001922	20 Amp fuse
6	99104001	10-24 x 1" phillips screw
6	99102002	10-24 Nylok nut
6	99103001	#10 SAE flat washer
2	90001913	12-10 Gauge Butt Connector
2	90001916	#10 x 5/16" Ring Terminal

Airlines & Fittings:

2	31940002	1/4" DOT airline – 30' roll
6	31954201	1/4" npt x 1/4" tube elbow fitting - air springs / tank
7	31954000	1/4" npt x 1/4" tube straight fitting - air valve
2	31952150	1/8" npt female x 1/4" tube straight fitting - compressor
2	31957003	1/8" npt nipple (install between FIT2150 & compressor)
3	31957004	1/4" npt plug - plug extra supply port
1	31954400	1/4" air line tee- compressors to check valve fitting
1	31959301	Check Valve- SCREWS INTO TANK FOR COMPRESSOR LINE

THE CHECK VALVE SUPPLIED SCREWS INTO THE AIR TANK WITH AN AIR FITTING THREADING INTO IT. THE COMPRESSOR LINES WILL FEED INTO THE CHECK VALVE.