

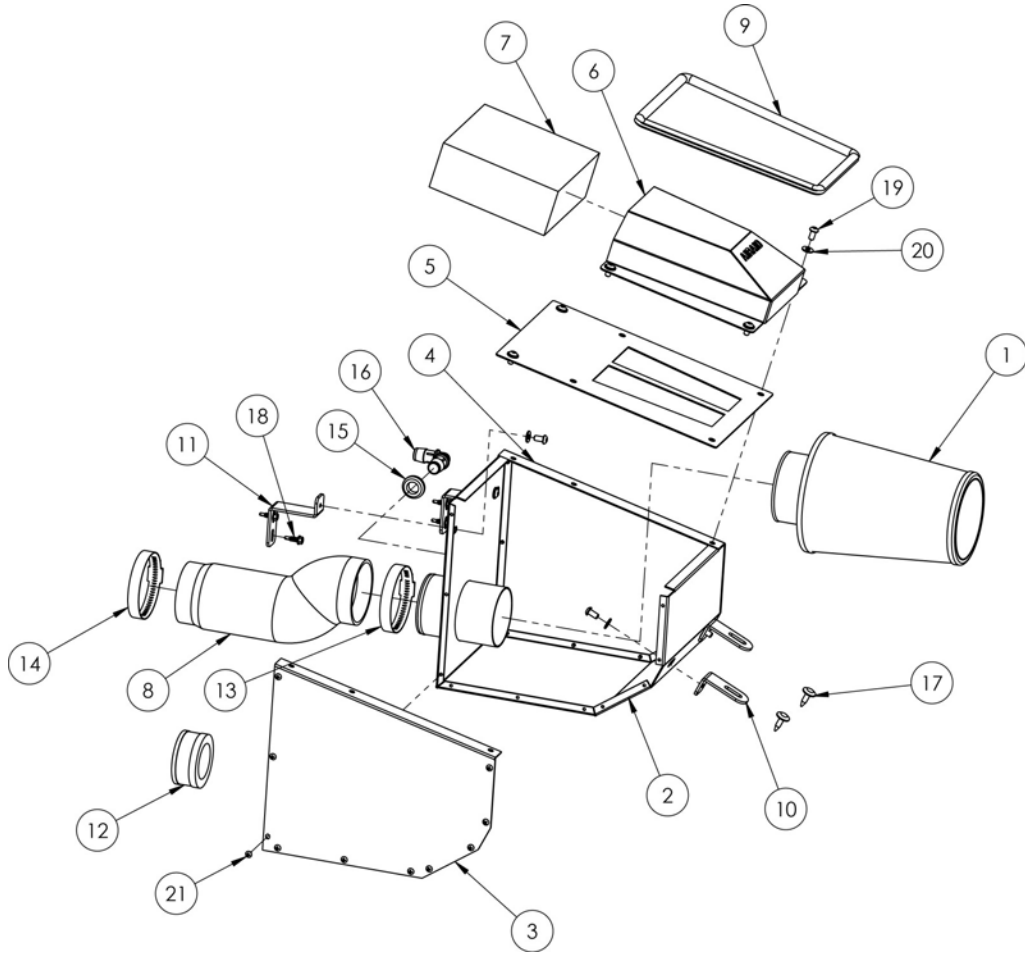

Installation Instructions

For Part Number:
883-290 Intake Kit

2013-15 Maverick 1000
1000cc



Component Identification

1.	Airaid Premium Filter	1
2.	Bottom Panel	1
3.	Left Panel	1
4.	Right Panel	1
5.	Top Panel	1
6.	Hood Scoop	1
7.	Foam Pre-Filter	1
8.	Silicone Coupler	1
9.	Rubber Edge Trim 33"	1
10.	Front Bracket	2
11.	Rear Bracket	2
12.	Firewall Cap	1
13.	#48 Hose Clamp	1
14.	#44 Hose Clamp	1
15.	5/8" Grommet	1
16.	5/8" Elbow	1
17.	Plastic Rivet	2
18.	Self Drilling Screw	4
19.	1/4-20 x 1/2" Button Head Screw	10
20.	1/4" Flat Washer	10
21.	8-32 Thread Cutting Screw	20
22.	Bubble Sticker	1

NOTE: Please read these install instructions in their entirety before beginning the installation process. A successful installation will require the use of an assistant in two separate steps.

Airaid recommends the use of Medium Strength Thread Locker on all threaded fasteners.

Full color instructions can be viewed on our web site at Airaid.com. Use the **Product Search** function to find your part number, and click **View Details**.



1. Disconnect The Negative Battery Terminal. It is located above the exhaust, in the rear of the vehicle.



2. Remove the center section of the hood to gain access to the airbox assembly.



3. Remove the two Torx screws from the top of the center console.



4. Open the glove box and remove the two plastic rivets on each side the center console.



5. Pull the console out and lay it on top of the hood.



6. Loosen throttlebody clamp .

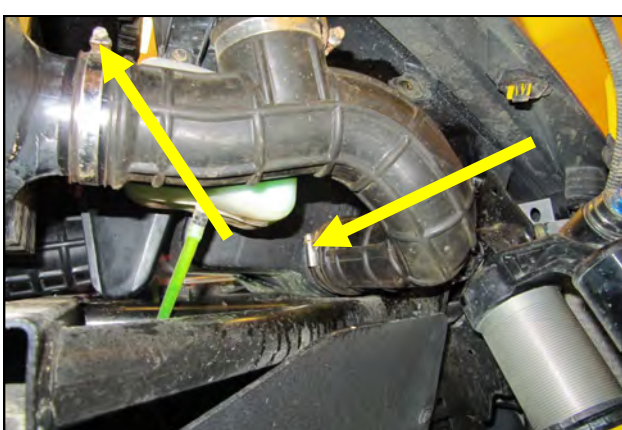

7. Inside the passenger side inner fender area, loosen the air inlet tube clamps and remove the tube.

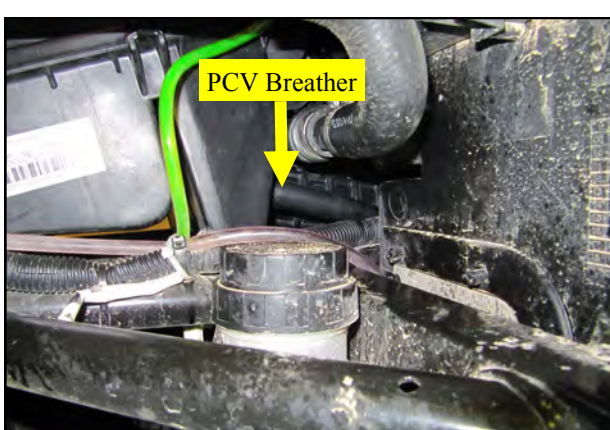

8. Inside the driver side inner fender area, Disconnect the PCV breather from the airbox.

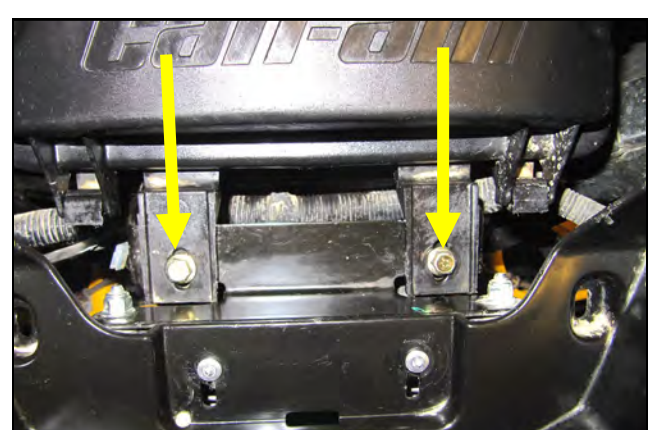

9. Remove the two front airbox nuts and bolts in the core support bracket.



10. Drill out the rivet heads holding plastic to the core support.



11. Unclip the upper half of the airbox and remove it along with the air filter.



12. Remove one of the 6mm bolts in the coolant bottle bracket to release it and set the bottle inside the compartment.



13. Remove the two 8mm nuts and bolts in the upper bumper mounts.

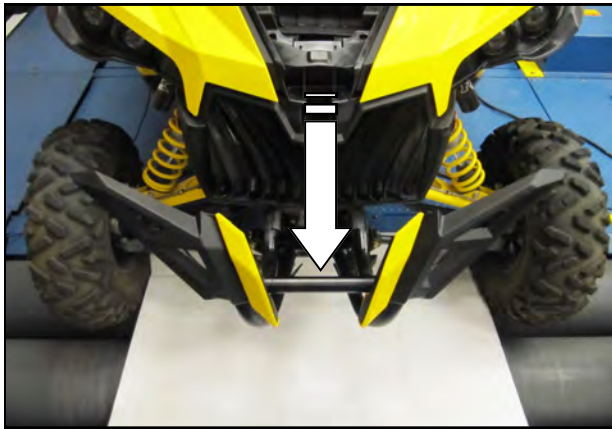

14. Swing the bumper out and away from the front end as far as it will go.

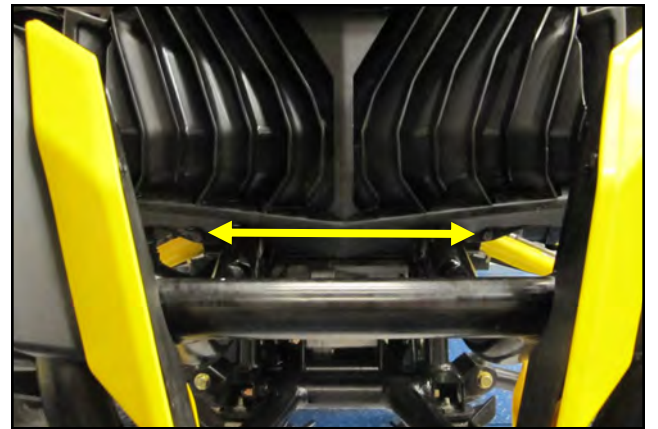

15. Remove the two 6mm Torx screws in the front of the grill.



16. With the help of an assistant, lift the front plastic away from the vehicle and remove the lower half of the airbox.

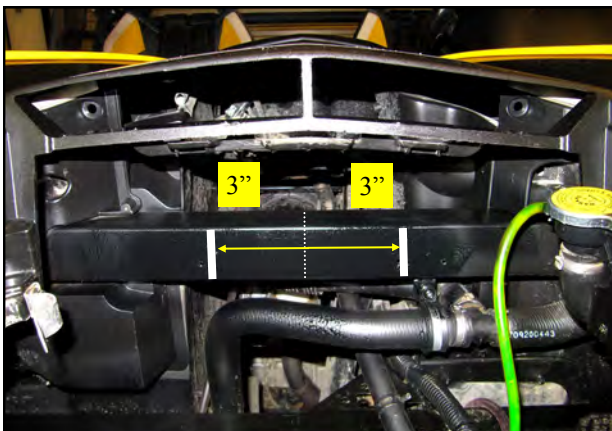

17. Find the center line on the cross member underneath the cowl and mark it . From that centerline, measure out 3\"/>



18. Using one of the Rear Brackets (#11) and a spring loaded punch, mark the cross member at both 3\"/>

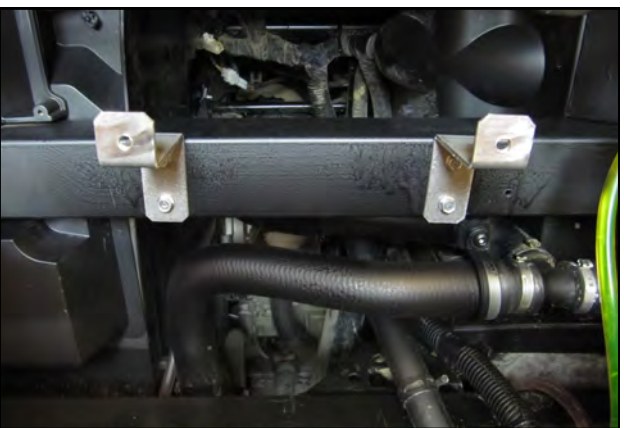

19. Using a drill and a 8mm socket bit, mount the Rear Brackets to the cross member with the four, Self Drilling Screws (#18) .

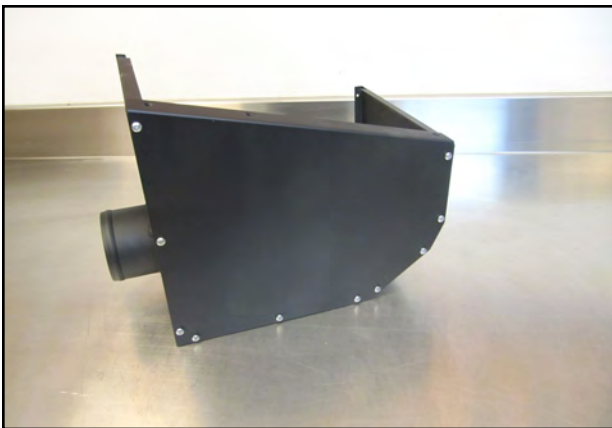

20. Install the Left Panel (# 3) onto the Bottom Panel (#2) using the #8-32 Thread Cutting Screws (#21).

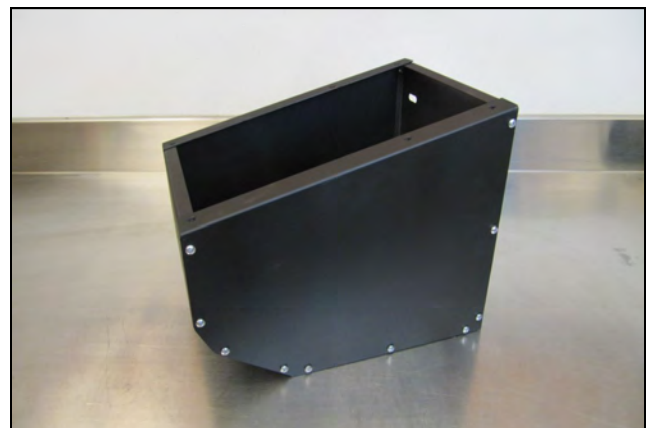

21. Install the Right side Panel (# 4) onto the Bottom Panel using the #8-32 Thread Cutting Screws .

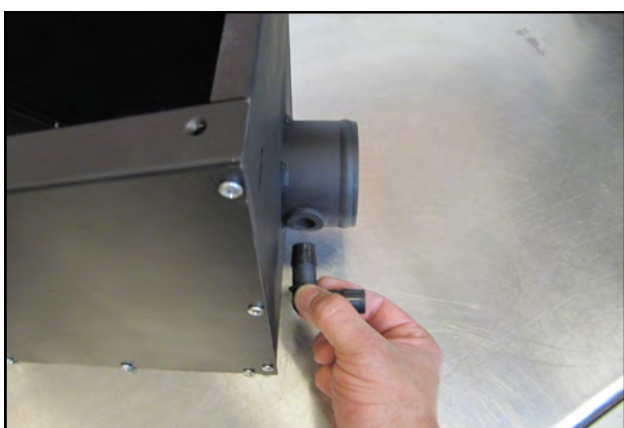

22. Install the Grommet (#15) and Elbow Fitting (#16) into the Airbox Tube.

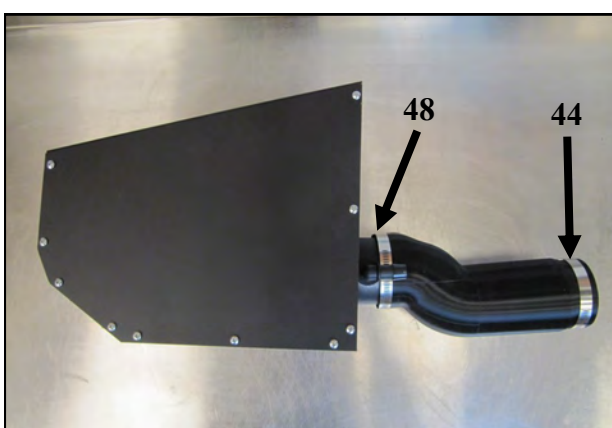

23. Slide the Silicone Coupler (#8) onto the Airbox tube as shown. Pre install the #44 and #48 Clamps onto the Coupler without tightening them.

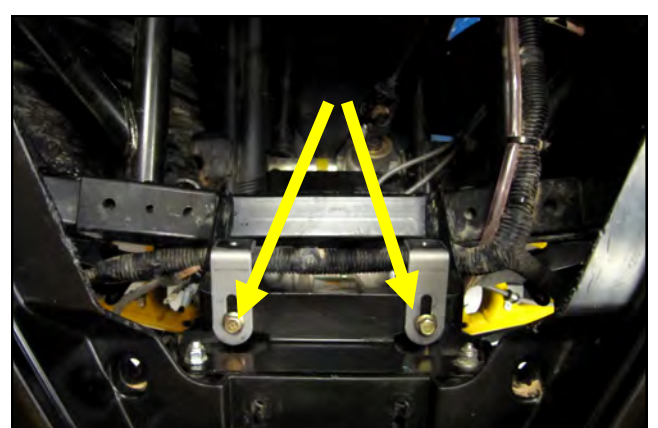

24. Mount the Front Brackets (# 10), as shown using the OEM hardware. Leave these bolts hand tight until final adjustment.

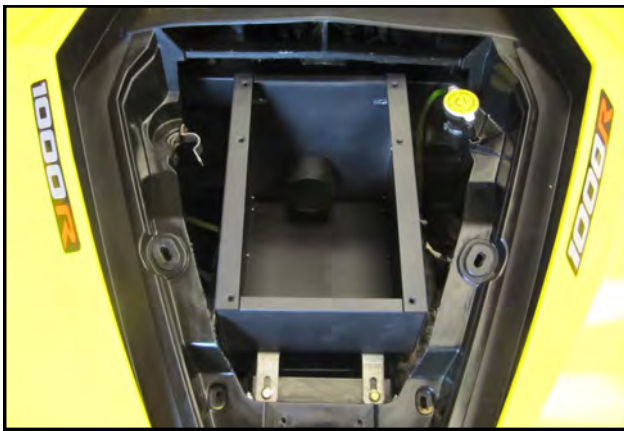

25. With the help of an assistant, insert the intake assembly into the vehicle from the front while a second set of hands guides the Coupler and Clamp onto the throttlebody from the back.

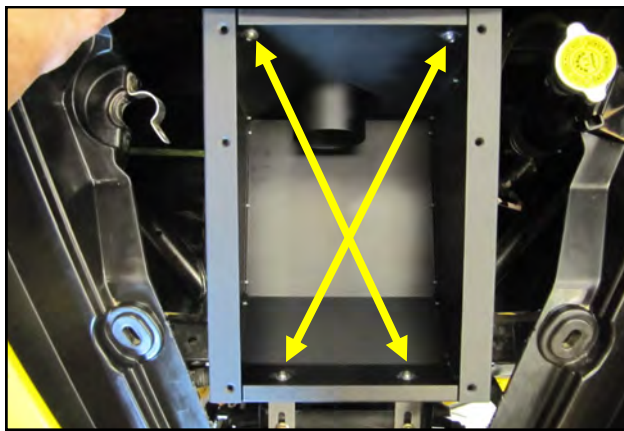

26. Secure the Intake assembly to the Front and Rear Brackets using the four 1/4-20 Button Head Screws (#19) and 1/4" Flat Washers (#20).

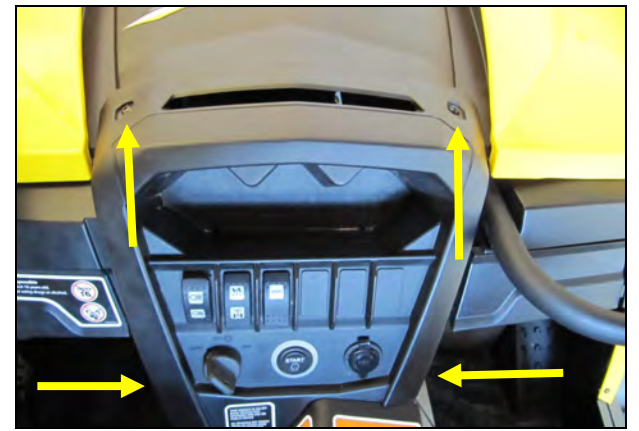

27. Tighten the throttlebody clamp and reinstall the center console using the factory hardware. Close the glove box.

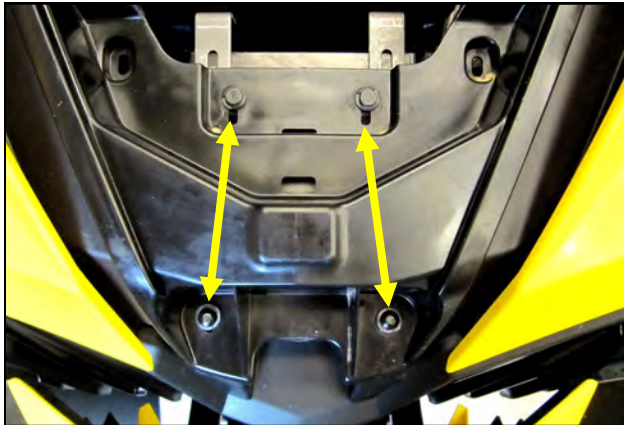

28. Insert the Plastic Rivets (#17) into the plastic covering the core support, where the factory metal rivets were. Reinstall the OEM screws in the front plastic.

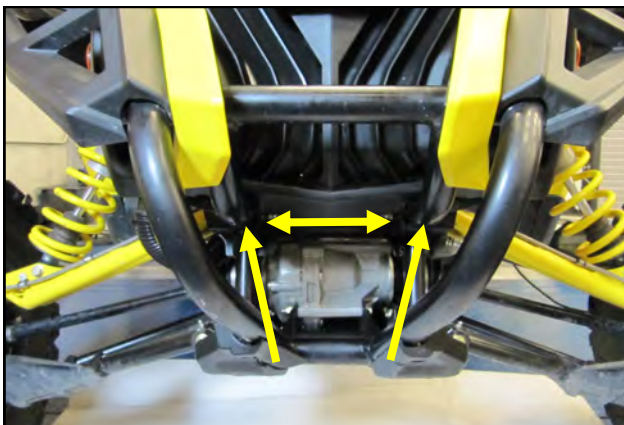

29. Return the bumper to its upright position and reinstall the 8mm bolts and nuts. Reinstall the grill screws.



30. Reinstall the coolant bottle.

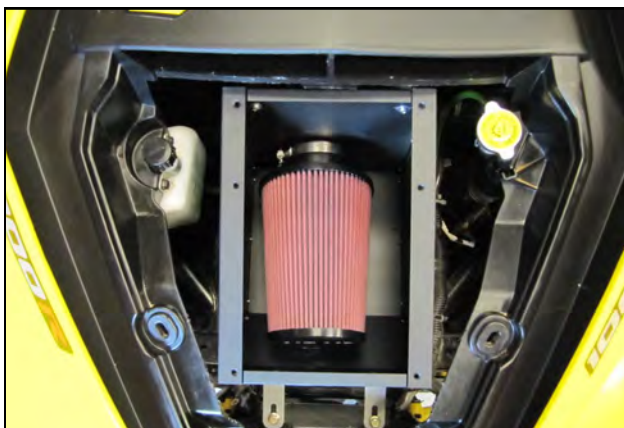

31. Slide the Airaid Premium Filter onto the inner Air-Box tubing and tighten the Clamp.



32. Connect the PCV line to the Elbow Fitting on the Intake. Note that the factory spring clamp is reused.

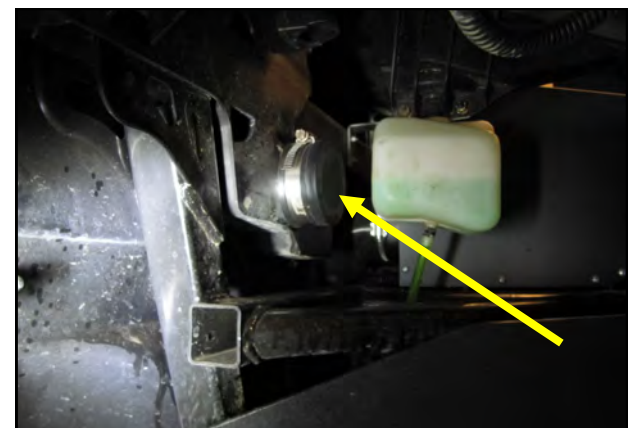

33. Install the Firewall Cap in the passenger side inner fender. (See step 7). Tighten the #48 clamp on the coupler from step 23.

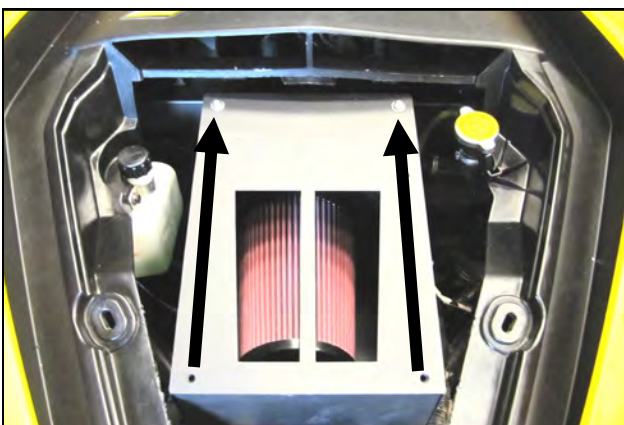

34. Install the Top Panel (#5) onto the Airbox using two 1/4-20 Button Heads and Flat Washers as shown.

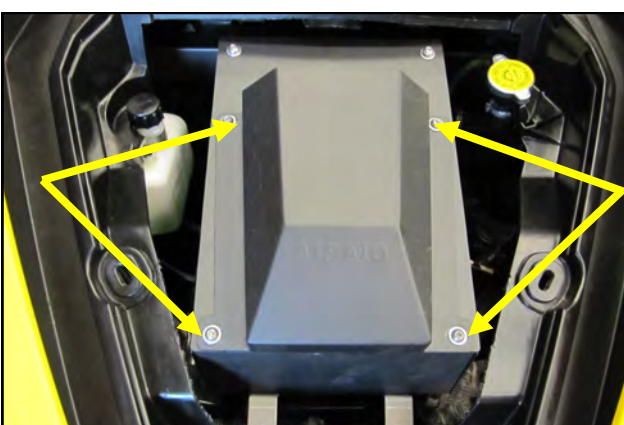

35. Mount the Hood Scoop onto the Airbox assembly as shown using four sets of 1/4-20 Button Heads and Washers.



36. Prepare the hood for cutting by laying tape strips side by side all across the center section for scratch protection. Cut out the Template and tape it into position. Using a 1/8" bit, drill out four pilot holes in the hood followed by a 1/2" bit to finish.



37. Using a jigsaw or equivalent, cut along the template line and connect the 1/2" holes. Remove the hood center, Template and tape.

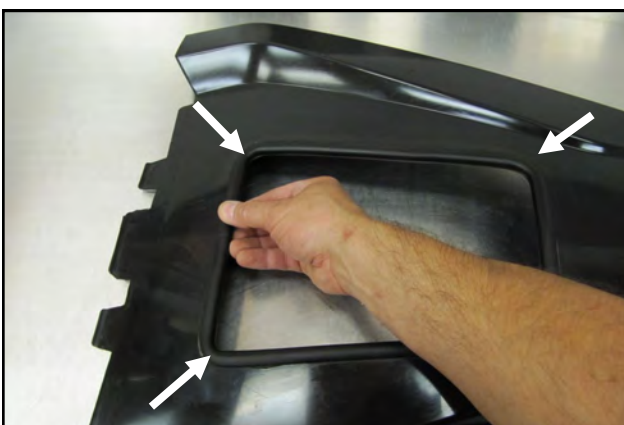

38. Finish the hood modification by installing the Rubber Edge Trim (#9) onto the cut edge.



39. Compress and install the Foam Pre Filter (#7) into the Hood Scoop.



40. Reconnect the battery. Double check your work. Make sure there is no foreign material in the intake path. Make sure all clamps, hoses, bolts, and screws are tight. Double check the hood clearances, make adjustments if necessary and tighten the two front airbox bolts. (See step 9)



Pre Filter Option Part Number 799-420

For maximum protection in the harshest of environments Airaid offers a slip on Pre Filter.

- Prolongs Cleaning Intervals
- Water Repellant
- Free Flowing Protection

Thank you for purchasing the Airaid Intake System. Contact Airaid @ (800) 498-6951 8:00 AM - 5:00 PM MST weekdays for questions regarding fit or instructions that are not clear to you. Your Airaid Intake System was carefully inspected and packaged. Check that no parts are missing, or were damaged during shipping. If any parts are missing, contact Airaid. The air filter element is protected from direct exposure to water and debris; care should be taken not to drive through deep water. WATER INGESTION IS THE DRIVERS RESPONSIBILITY! The air filter is reusable and should be cleaned periodically.

**For your Oiled media filter
we suggest using the AIRAID
Filter Tune-Up Kit!**



**P/N 790-551 Aerosol Spray
P/N 790-550 Squeeze Spray**



ALIGN WITH EDGE OF HOOD

MARK HOLE CENTERS WITH CENTERPUNCH
AND DRILL WITH 1/2" BIT

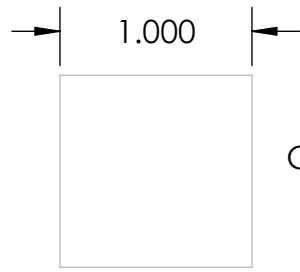

CHECK SIZE OF SQUARE TO CONFIRM
SCALE BEFORE CUTTING