



AEROMOTIVE
Part # 11806
Diesel Lift Pump 230 gph
INSTALLATION INSTRUCTIONS

CAUTION:

Installation of this product requires detailed knowledge of automotive systems and repair procedures. We recommend that this installation be carried out by a qualified automotive technician.

Installation of this product requires handling of diesel. Ensure you are working in a well ventilated area with an approved fire extinguisher nearby. Extinguish all open flames, prohibit smoking and eliminate all sources of ignition in the area of the vehicle before proceeding with the installation.

When installing this product, wear eye goggles and other safety apparel as needed to protect yourself from debris and sprayed diesel.

Aeromotive system components are not legal for sale or use on emission controlled motor vehicles.

This kit contains the following parts:

1 ea Fuel Pump Assembly (230gph)	1 ea Spring, 20-40psi
2-20psi spring installed	1 ea Spring, 30-60psi

PUMP SPECS:

Regulator Adjustment Pressure Range:	2-60psi
Flow Output @ 13.5V:	230gph @ 10psi
Filter Micron Rating:	2 Micron (CATERPILLAR 1R-0750)
Coolant Ports:	AN-08 ORB
Inlet Port:	AN-12 ORB
Outlet/Return Port:	AN-10 ORB
Filter Threads:	1"-14
Factory Pressure setting:	10 psi
Gauge Port:	1/8" NPT

WARNING: DO NOT REVERSE POLARITY ON PUMP. PUMP DAMAGE AND FAILURE WILL OCCUR!

DESIRED LINE SIZE	AEROMOTIVE PORT FITTING PART #
INLET - 12AN	15612
- 5/8" J2044 (male)	15130
OUTLET - 12AN	15642
- 10AN	15608
- 8AN	15610
- 1/2" J2044 (male)	15129
RETURN - 12AN	15642
- 10AN	15608
- 8AN	15610
- 1/2" J2044 (male)	15129

WARNING!



Always be aware of flammable situations. Drilling and grinding can be potential ignition sources. Extinguish all open flames, prohibit smoking and eliminate all sources of ignition in the area of the vehicle and workspace before proceeding with the installation. Ensure you are working in a well ventilated area with an approved fire extinguisher nearby.

WARNING!



Installation of this product requires modification to a fuel tank, failure to satisfy all safety considerations will result in fire, explosion, injury and/or loss of life to yourself and/or others.

WARNING!



Mechanical and hydraulic lifting devices can tip over or lower accidentally due to incorrect maneuvering or technical errors. A falling object can cause injury and/or loss of life to yourself and/or others. When working under the vehicle always use stands and ensure that the ground or floor is stable and level. Never crawl under a vehicle which is only supported by a jack.

CAUTION:



Make sure all batteries are disconnected before starting installation. Most diesel truck have two 12v batteries.

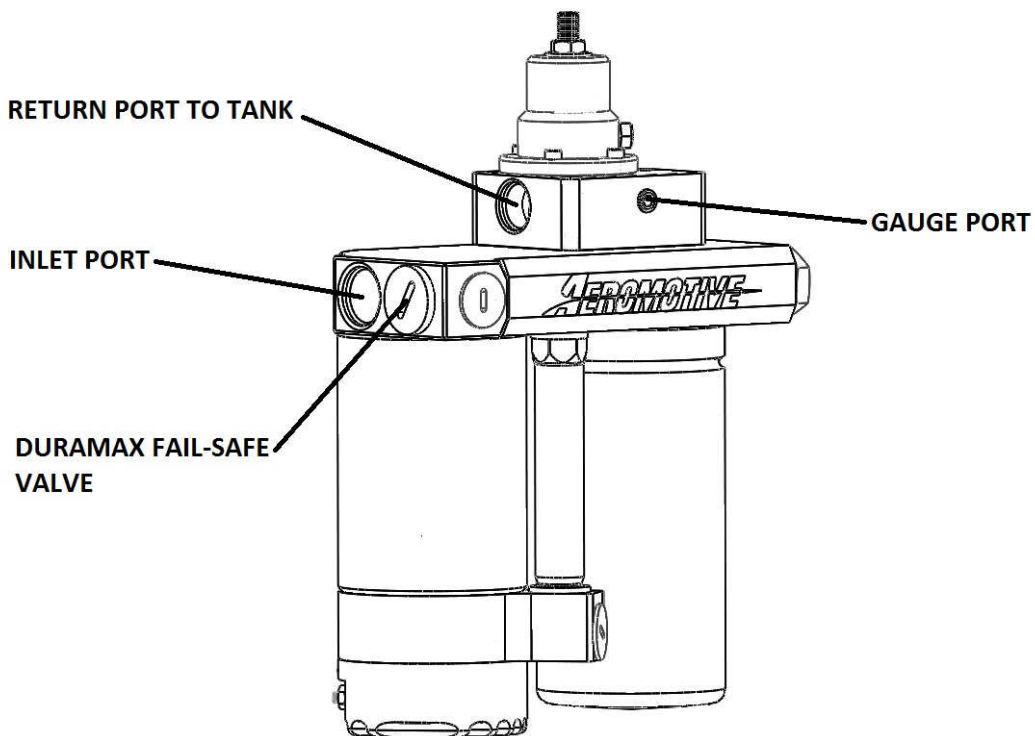

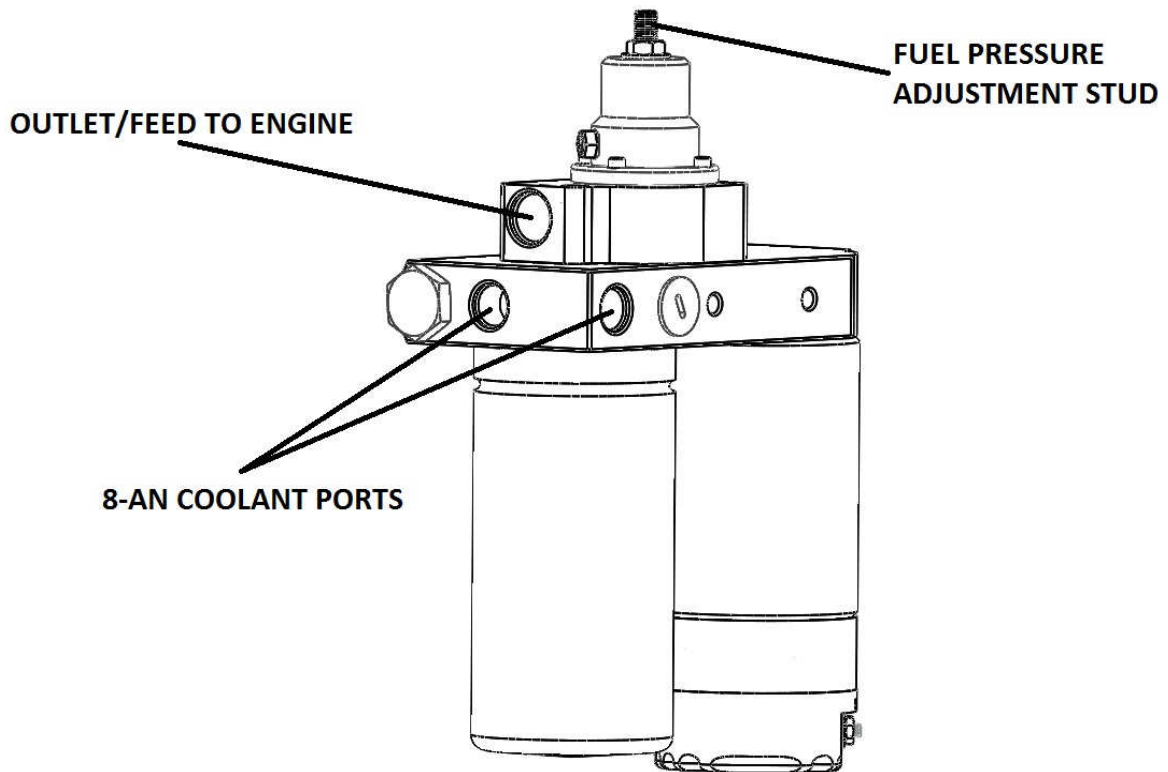

FUEL LINE CONNECTION LAYOUT:

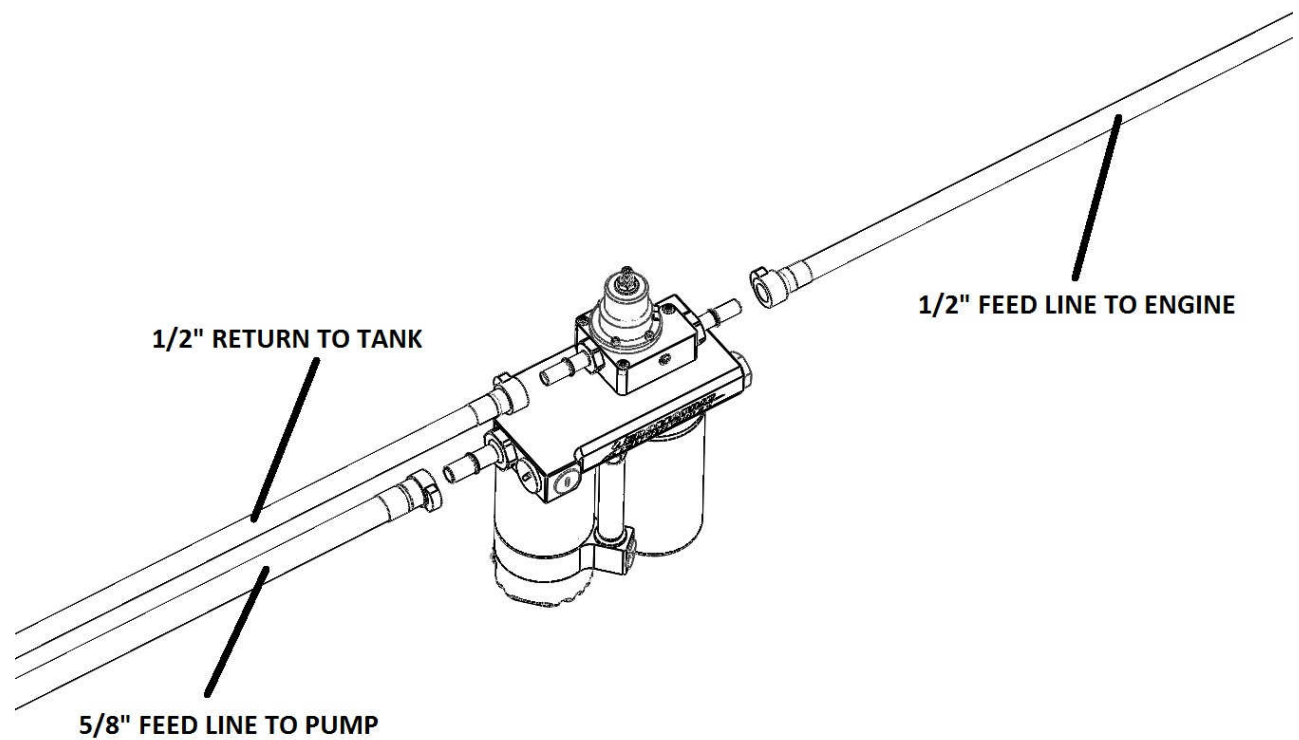

1. Select and install the pressure spring that best fits your pressure range. To swap springs, simply remove the four socket head cap screws, remove the top cap and replace spring. **FIGURE 1-1**

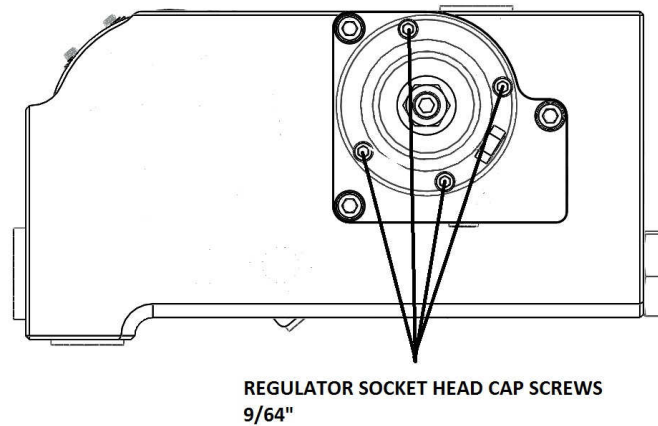

FIGURE 1-1

2. Find a suitable location to mount the fuel pump. Mount pump utilizing the two 3/8"-16 threaded mounting holes. **FIGURE 1-2**

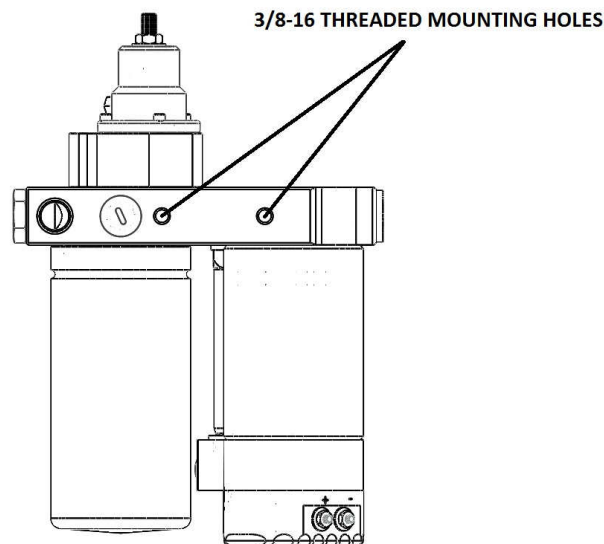

FIGURE 1-2

3. **The Aeromotive Diesel Lift Pump does not have a pre-filter and one must be installed. Aeromotive recommends filter part # 12307 (100 micron). Install the filter in between the fuel pump inlet and fuel tank.**

WARNING: Failure to install the correct pre-filter on the suction side of the pump will cause pump damage and void the warranty.

4. The feed line to the pump must at least be 5/8" ID or larger. Assemble the feed line with the appropriate pre-filter install before the pump. **Refer to fittings chart for help.**
5. Assemble and connect your return line to regulator return port (minimum 1/2" ID). Direct this line to the top of your tank/fuel cell.

6. Assemble and connect your engine feed line to the outlet port on the pump (see fitting chart for fitting sizes).
7. Make sure you use stranded, insulated copper wire, in the sizes shown, with matching crimp-type connectors for all connections. Or Aeromotive **Part # 16307** for a pre-made wiring harness.

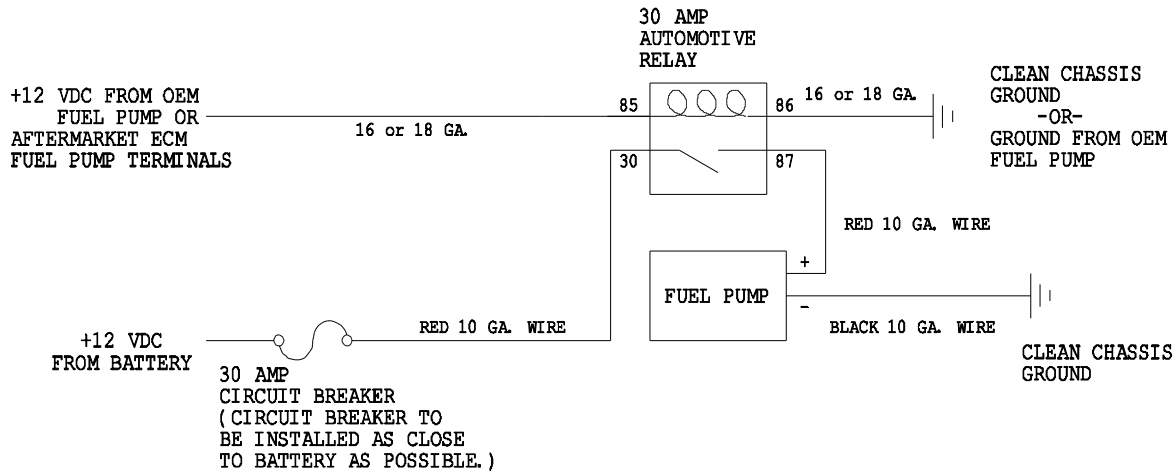

8. Attach a suitable, fuel pressure gauge or one of the new Aeromotive liquid filled gauges with equalizer valve to the fuel pressure regulator.
P/N 15632 0-15 PSI (1 1/2") "Liquid Filled" Fuel Pressure Gauge with equalizer valve.
P/N 15633 0-100 PSI (1 1/2") "Liquid Filled" Fuel Pressure Gauge with equalizer valve.

Ensure that any spilled fuel and any fuel soaked shop towels are cleaned up and removed from the vicinity of the vehicle.

CAUTION: While performing the following steps, if any fuel leaks are detected, immediately turn the ignition to OFF, remove any spilled fuel and repair the leak(s) before proceeding!

9. Turn the ignition to ON **without starting the engine**, allow the pump to run for several seconds and check the fuel pressure. If there is no pressure, turn the ignition to OFF, wait one minute, then turn the ignition to ON and recheck the pressure. Repeat this ignition OFF and ON procedure until the gauge registers pressure or you detect a fuel leak. If no pressure is registered on the gauge after running the pump for several seconds and you have found no leaks, check all fuel and electrical connections to determine the cause.
10. Once the fuel pressure gauge registers pressure, adjust to your desired pressure. To adjust fuel pressure, turn the adjuster stud clockwise to raise pressure while counter clockwise lowers pressure.
11. Shut the engine off. Using suitable clips and other mounting hardware, secure the newly installed fuel lines and electrical wires by attaching them to the vehicle chassis.
12. Test-drive the vehicle to insure proper operation and re-check the fuel system for leaks. **If any leaks are found, immediately discontinue use of the vehicle and repair the leak(s)!**

FUEL FILTER CROSS REFERENCE

Part #	Manufacturer	Description	Micron Rating
BF1258	Baldwin	Fuel/Water Separator	10 Micron
BF1212	Baldwin	Fuel/Water Separator	
BF1214	Baldwin	Fuel/Water Separator	
175-2949	CAT	Fuel/Water Separator	
1R-0750	CAT	Fuel Filter	2 Micron
P551000	Donaldson	Fuel/Water Separator	10 Micron
P551001	Donaldson	Fuel/Water Separator	20 Micron
P558000	Donaldson	Fuel/Water Separator	20 Micron
FS1000	Fleetguard	Fuel/Water Separator	10 Micron
FS1001	Fleetguard	Fuel/Water Separator	10 Micron
FS1009	Fleetguard	Fuel/Water Separator	14 Micron
FS1212	Fleetguard	Fuel/Water Separator	14 Micron
LFF1223	Luber Finer	Fuel/Water Separator	
LFF8000	Luber Finer	Fuel/Water Separator	
3406	Napa	Fuel/Water Separator	14 Micron
3407	Napa	Fuel/Water Separator	5 Micron
3405	Napa	Fuel/Water Separator	14 Micron
33407	WIX	Fuel/Water Separator	5 Micron
33115	WIX	Fuel Filter	10 Micron
33504	WIX	Fuel/Water Separator	14 Micron

AEROMOTIVE, INC. LIMITED WARRANTY

This Aeromotive Product, with proof of purchase dated on or after January 1, 2003, is warranted to be free from defects in materials and workmanship for a period of one year from the original date of purchase. No warranty claim will be valid without authentic, dated proof of purchase.

This warranty is to the original retail purchaser and none other and is available directly from Aeromotive and not through any point of distribution or purchase.

If a defect is suspected, the retail purchaser must contact Aeromotive directly to discuss the problem, possible solutions and obtain a Return Goods Authorization (RGA), if deemed necessary by the company. Please call 913-647-7300 and dial option 3 for the technical service dept. All returns must be shipped freight pre-paid to the company and with valid RGA before they will be processed.

Aeromotive will examine any product returned with the proper authorization to determine if the failure resulted from a defect or from abuse, improper installation, misapplication or alteration. Aeromotive will then, at it's sole discretion, return, repair or replace the product.

If any Aeromotive product is determined defective, buyer's exclusive remedy is limited in value to the sale price of the good. In no event shall Aeromotive be liable for incidental or consequential damages.

Aeromotive expressly retains the right to make changes and improvements in any product it manufactures and sells at any time. These changes and improvements may be made without notice at any time and without any obligation to change the catalogs or printed materials.

Aeromotive expressly retains the right to discontinue at any time and without notice any Aeromotive product that it manufactures or sells.

This warranty is limited and expressly limits any implied warranty to one year from the date of the original retail purchase on all Aeromotive products.

No person, party or corporate entity other than Aeromotive shall have the right to: determine whether or not this Limited Warranty is applicable to any Aeromotive product, authorize any action whatsoever under the terms and conditions of this Limited Warranty, assume any obligation or liability of any nature whatsoever on behalf of Aeromotive under the terms and conditions of this Limited Warranty.

This Limited Warranty covers only the product itself and not the cost of installation or removal.

This Limited Warranty is in lieu of and expressly excludes any and all other warranties, expressed or implied. This Limited Warranty gives you specific legal rights, and you may also have other rights which vary from state to state.