



Installation Instructions

HOSS™ Door Cart & Cover



Hardtop Organized Storage System





Application:

- Jeep CJ, Wrangler, Wrangler Unlimited Doors

Part Number: 42814

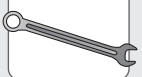
www.Bestop.com - We're here to help! Visit our web site and click on "[Ask a Question](#)". Click here for more [Jeep Accessories by Bestop](#).

| INSTALLATION TIME | SKILL LEVEL |
|---|---|
|  2 Hours |  2 - Moderately Easy |

| TOOLS | | | |
|--|---|---|---|
|  Wrench 7/16", 3/4" and 9/16" |  Tape Measure |  Phillips Screwdriver |  Safety Glasses |
|  Torx Socket T-50 | | | |



CAUTION

Safety glasses should be worn at all times while installing this product.

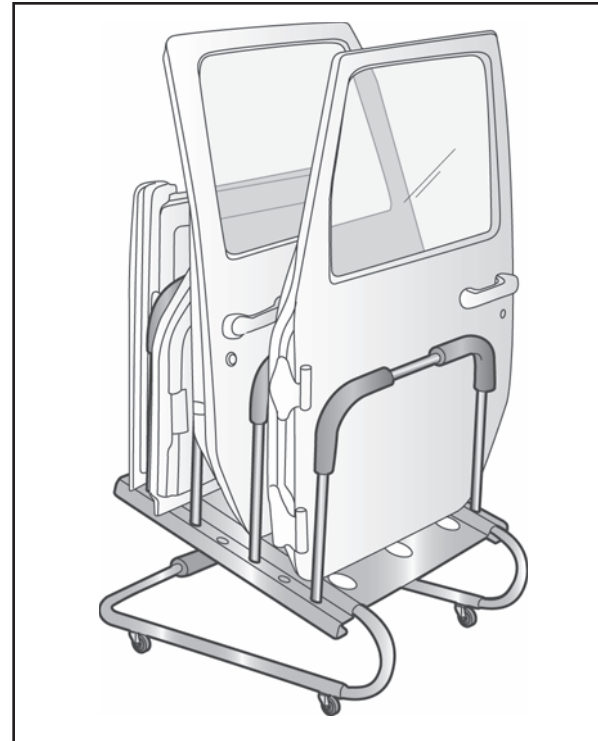

Installation Tips

Before you begin installing the HOSS™ Cart & Cover, read all instructions thoroughly to avoid damage to the product.

It is normal for the fabric to contract and wrinkle when stored in the shipping carton. Within a few days after the installation, the fabric will relax and the wrinkles will disappear.

HOSS™ Door Cart Installation Instructions

Parts List and Hardware Identification

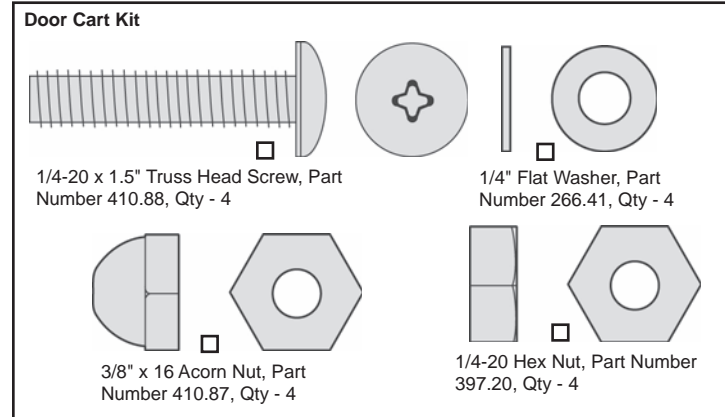
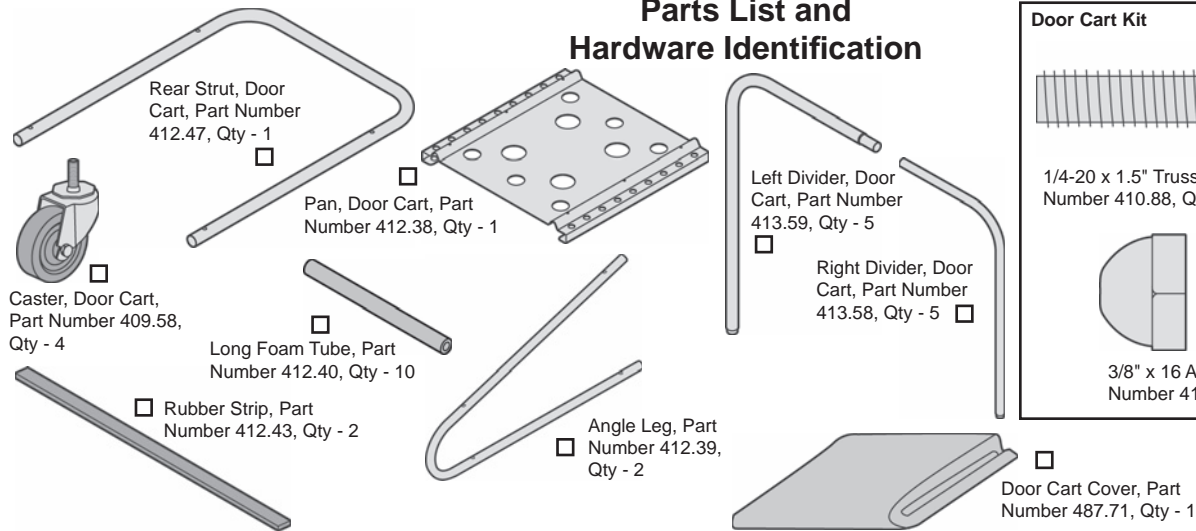

1 Assemble Dividers - Door Cart

Slide a Long Foam Tube over one half of each pair of Dividers. Slide the sleeve up and around the bend. Press the Divider halves together. Assemble five (5) Dividers.

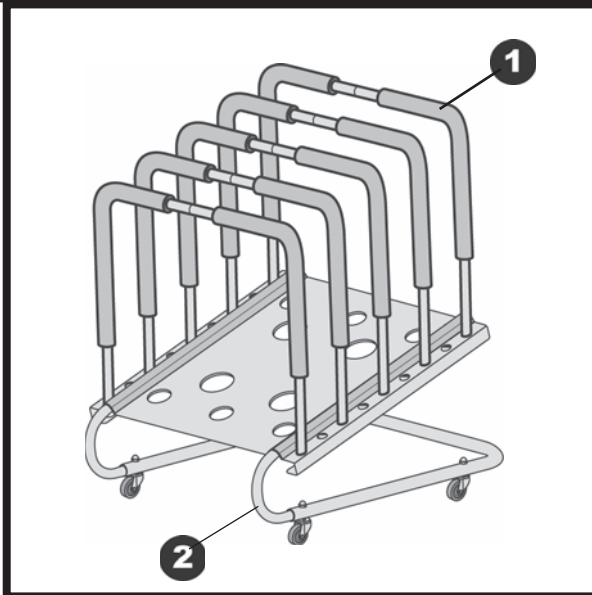
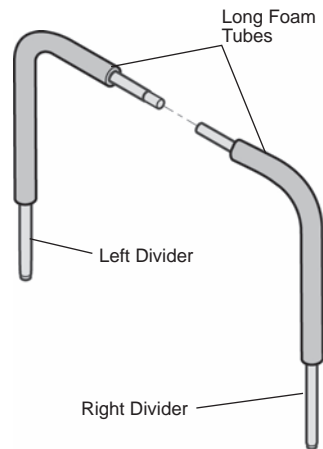

2 Install Angle Legs and Casters on Door Cart Rear Strut

Locate the Angle Legs and Rear Strut in the parts kit. Slide the Angle Legs into the ends of the Rear Strut and align the holes. Install a Door Cart Caster in each set of holes with a 3/8-16 Acorn Nut. Do not tighten the nuts at this time.

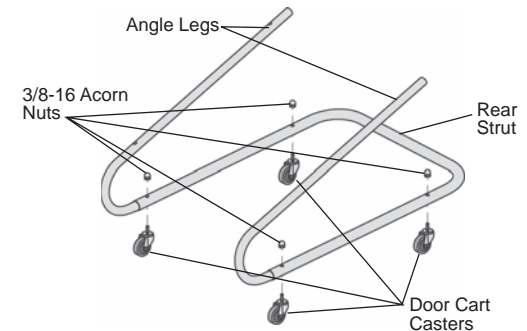

HOSS™ Door Cart Installation Instructions

3 Install Door Cart Pan

Orient the Door Cart Pan on the Door Cart Assembly so the holes in the lower ledge along the side of the pan are toward the bottom of the pan in relation to the holes in the top layer. Align the mounting holes in the pan with the mounting holes on the Angle Legs and install a 1/4-20 x 1.5 Truss Head Screw, 1/4" Washer and 1/4-20 Hex Nut in each hole.

Tighten the Truss Head Screws then tighten the Acorn Nuts that secure the Casters to the Door Cart.

Holes in bottom must be lower than holes in top

1/4-20 x 1.5 Truss Head Screws

1/4" Washers and 1/4-20 Hex Nuts

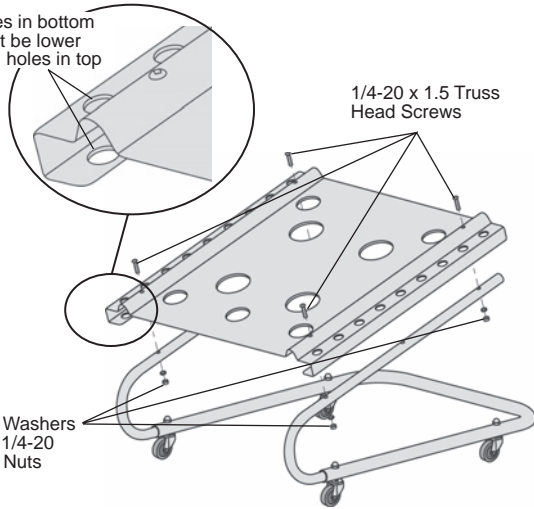

4 Install Rubber Strips

Orient the Rubber Strips along the top of the mounting ridges, over the heads of the Truss Head Screws. Center the strips from top to bottom on the pan. Peel the backing off the strips a little at a time and press them firmly into place.

Install Rubber Strips on ridges

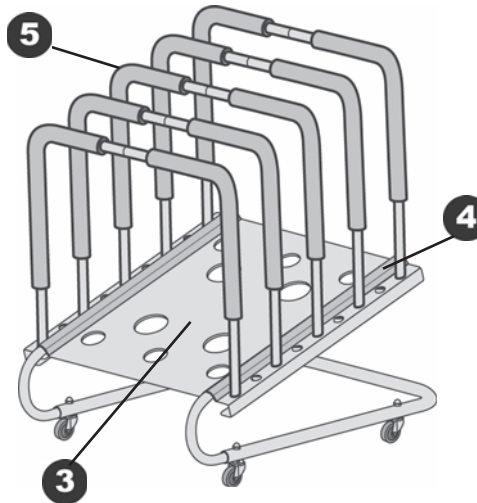
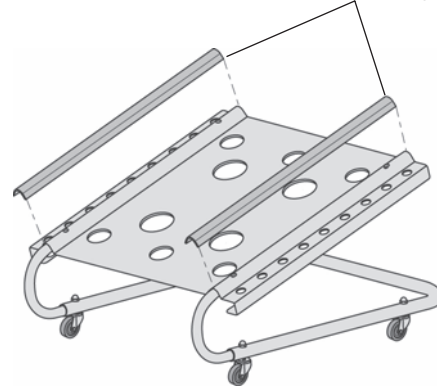

WARNING

The maximum load for the Door Cart is 235 lbs.



5 Install Dividers in Door Cart

Insert the Dividers into the holes along the sides of the Cart Pan. The ends of the Dividers should fit securely into the mounting holes.

NOTE

Store taller doors toward the back of the Door Cart with shorter doors toward the front.

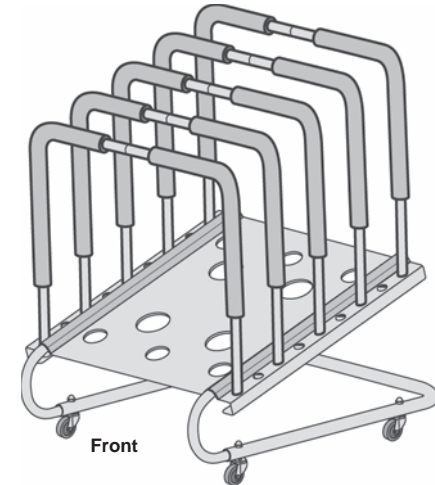

NOTE

Store taller doors toward the back of the Door Cart with shorter doors toward the front.

HOSS™ Door Cart Installation Instructions

Removing your Doors

6 Remove Torx Bolts

Loosen and remove the Torx bolts from the door hinge. The 2007 – Current Jeep Wrangler requires a #50 Torx. Earlier Wrangler models may use a 13mm wrench.

NOTE To avoid costly replacement of parts, please set aside all nuts, bolts and other removable parts in a safe place for future reinstallation.

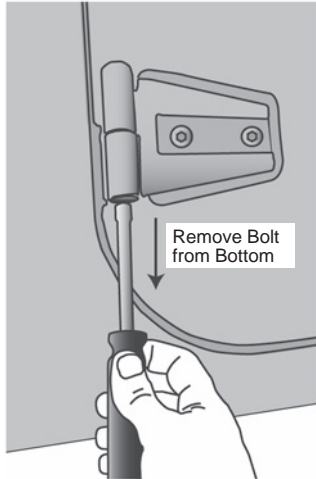

7 Disconnect Door Strap / Cable

Disconnect the door restraining strap and any wiring or cables plugged into the door. Depending on the door type, you may need to refer to the installation manual of the door for proper disconnection.

8 Remove Door

To avoid injury or damage to the door, gauge the weight of the door to the available strength provided. Some doors may need two people to remove.

With both hands, lift the door upward and out of the hinges. If the door was factory installed, and you are removing it for the first time, shift the door slightly back and forth to loosen the excess paint inside the hinge.



9 Install Door Cart Cover

Secure the doors and other components between the dividers on the door cart. Drape the cover over the parts stretching the elastic of the opening around the components and down to the base of the cart.

NOTE Before installing the cover, make sure items within the cart are secure.

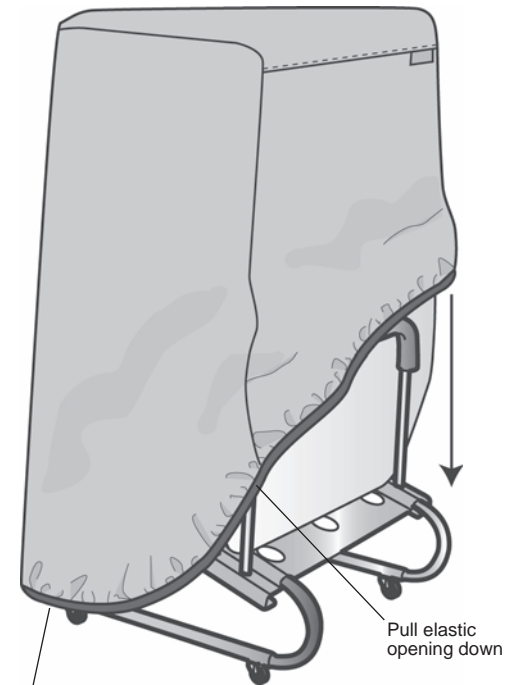

Elastic should fit over the base when covering 2007 Wrangler and Wrangler Unlimited Full Doors

HOSS™ Door Cart Installation Instructions

Care and Maintenance of your Bestop Product

Your Bestop product is made of the finest materials available. To keep it looking new and for the maximum possible wear, it will need periodic cleaning and maintenance.

Fabric: The fabric should be washed often using soap, warm water and a soft bristle brush. Rinse with clear water to remove all traces of soap. Bestop recommends using Bestop Cleaner (part no. 11201-00) and Bestop Protectant (part no. 11202-00). Bestop Cleaner and Bestop protectant are specially formulated to provide a total cleaning and protection system. Bestop Cleaner safely removes the toughest stains, will not harm vehicle finishes, is biodegradable and environmentally friendly. Bestop Protectant protects against UV-fading, cracking and hardening, and repels dust, grease, dirt and mildew.

Water: Seeping through at the seams may be stopped by applying 3-M Scotchgard® on the inside of the seams. Rips in the fabric may be repaired with Bondex® iron on patches. Iron the patches to the inside of the top, carefully following the Bondex® instructions.

Limited Warranty

We warrant our product to be free from defects in material and workmanship, for the terms specified below, provided there has been normal use and proper maintenance. This warranty applies to the original purchaser only. All remedies under this warranty are limited to the repair or replacement of any item or items found by the factory to be defective within the time period specified.

If you have a warranty claim, first you must call our factory at the number below for instructions. You must retain proof of purchase and submit a copy with any items returned for warranty work. Upon completion of warranty work, if any, we will return the repaired or replaced item or items to you freight prepaid. Damage to our products caused by accidents, fire, vandalism, negligence, misinstallation, misuse, Acts of God, or by defective parts not manufactured by us, is not covered under this warranty.

THE WARRANTY TIME PERIOD IS AS FOLLOWS: ALL "PRODUCTS" MANUFACTURED BY OUR COMPANY: ONE YEAR FROM DATE OF PURCHASE.

ANY IMPLIED WARRANTIES OF MERCHANTABILITY AND/OR FITNESS FOR A PARTICULAR PURPOSE CREATED HEREBY ARE LIMITED IN DURATION TO THE SAME DURATION AND SCOPE AS THE EXPRESS WRITTEN WARRANTY. OUR COMPANY SHALL NOT BE LIABLE FOR ANY INCIDENTAL OR CONSEQUENTIAL DAMAGE.

Some states do not allow limitations on how long an implied warranty lasts, or the exclusion or limitation of incidental or consequential damages, so the above limitations or exclusions may not apply to you.

This warranty gives you specific legal rights, and you may also have other rights which vary from state to state.



For further information or request for warranty work, please contact:
Bestop Inc. Customer Service
(800) 845-3567
(303) 465-1755