

RideCONTROL
by AIR LIFT®

No. 59565

***Chevrolet Silverado
1500 and GMC Sierra
1500***



INSTALLATION GUIDE

For maximum effectiveness and safety, please read these instructions completely before proceeding with installation.

Failure to read these instructions can result in an incorrect installation.

TABLE OF CONTENTS

Introduction	2
Important Safety Notice	2
Notation Explanation	2
Installation Diagram	3
Hardware List	3
Installing the RideControl System	4
Getting Started	4
Attaching the Upper Bracket to the Frame	4
Assembling the Air Sleeve	6
Installing the Air Assembly	6
Installing the Air Lines	7
Checking for Leaks	8
Fixing Leaks	8
Installation Checklist	9
Troubleshooting Guide	10
Maintenance and Servicing	10
Maintenance Guidelines	10
Warranty and Return Policy	11
Replacement Information	12
Contact Information	12

Introduction

The purpose of this publication is to assist with the installation, maintenance and troubleshooting of the RideControl air spring kit. The air springs used in RideControl kits are designed and manufactured like a tire. The air springs have layers of rubber and cords that control the bag's growth and funnel it into one direction. The bags do not require a coil spring for control. RideControl kits utilize a sleeve style air bag that provides up to 2,000 pounds of load-leveling support. Each sleeve is rated at a maximum of 100 p.s.i.

It is important to read and understand the entire installation guide before beginning installation or performing any maintenance, service or repair. The information here includes a hardware list, step-by-step installation information, maintenance tips, safety information and a troubleshooting guide.

Air Lift Company reserves the right to make changes and improvements to its products and publications at any time. Contact Air Lift Company at (800) 248-0892 or go online at www.airliftcompany.com for the latest version of this manual.

IMPORTANT SAFETY NOTICE

The installation of this kit does not alter the Gross Vehicle Weight Rating (GVWR) or payload of the vehicle. Check your vehicle's owner's manual and do not exceed the maximum load listed for your vehicle.

Gross Vehicle Weight Rating: The maximum allowable weight of the fully loaded vehicle (including passengers and cargo). This number — along with other weight limits, as well as tire, rim size and inflation pressure data — is shown on the vehicle's Safety Compliance Certification Label.

Payload: The combined, maximum allowable weight of cargo and passengers that the truck is designed to carry. Payload is GVWR minus the Base Curb Weight.

NOTATION EXPLANATION

Hazard notations appear in various locations in this publication. Information which is highlighted by one of these notations must be observed to help minimize risk of personal injury or possible improper installation which may render the vehicle unsafe. Notes are used to help emphasize areas of procedural importance and provide helpful suggestions. The following definitions explain the use of these notations as they appear throughout this guide.



DANGER

INDICATES IMMEDIATE HAZARDS WHICH WILL RESULT IN SEVERE PERSONAL INJURY OR DEATH.



WARNING

INDICATES HAZARDS OR UNSAFE PRACTICES WHICH COULD RESULT IN SEVERE PERSONAL INJURY OR DEATH.



CAUTION

INDICATES HAZARDS OR UNSAFE PRACTICES WHICH COULD RESULT IN DAMAGE TO THE MACHINE OR MINOR PERSONAL INJURY.

NOTE

Indicates a procedure, practice or hint which is important to highlight.

Installation Diagram

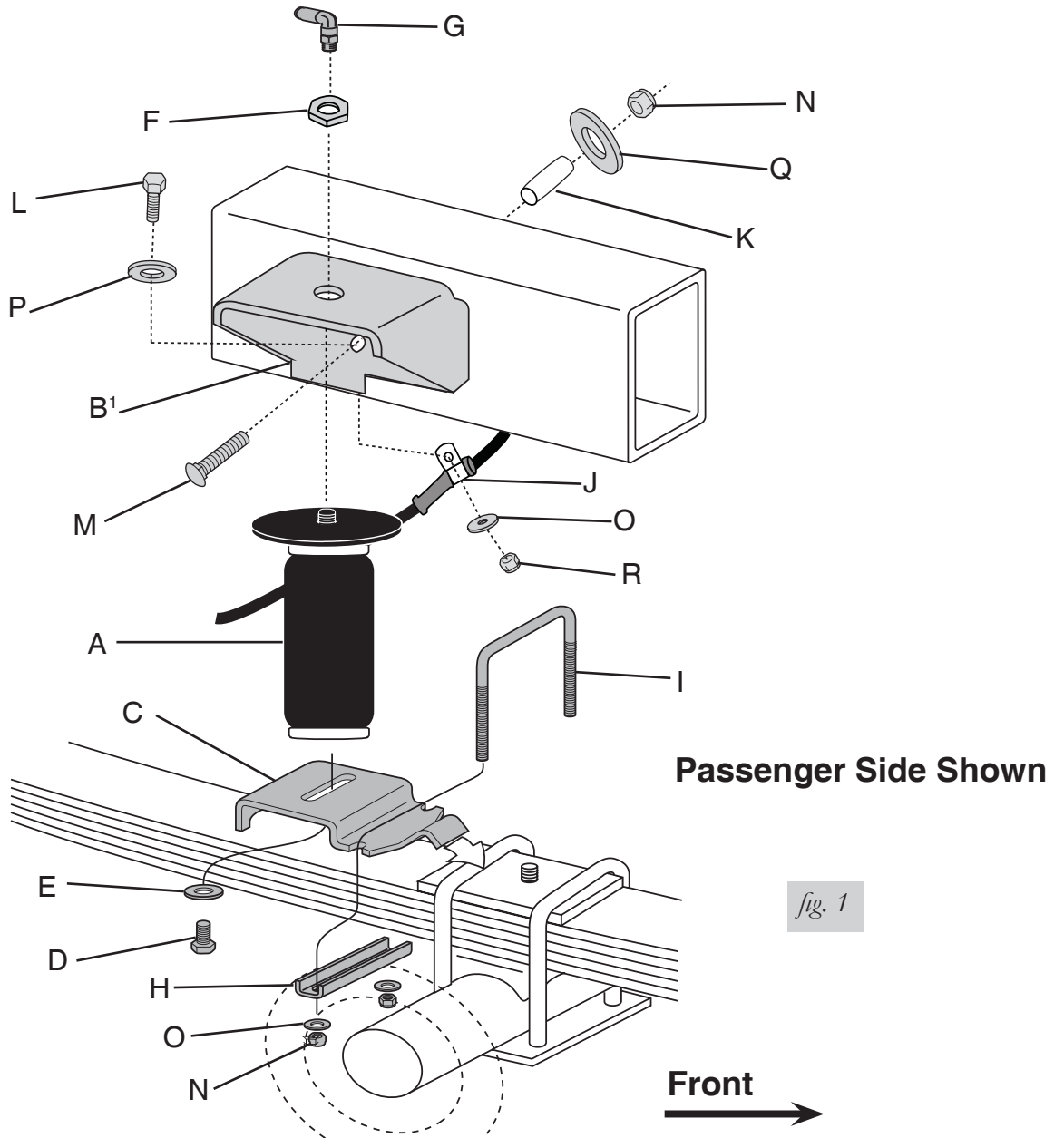

fig. 1

HARDWARE LIST

Item	Part #	Description.....Qty	Item	Part #	Description.....Qty
A	58571	Air sleeve2	O	18444	3/8" Flat washer6
B ¹	07234	Passenger side upper bracket1	P	18447	Medium OD washer2
*B ²	07375	Driver side upper bracket1	Q	10956	Large OD washer2
C	03616	Lower bracket2	R	18437	3/8" Nyloc nut G8 (gold)2
D	17124	1/2"-13 x 7/8 Bolt2	*AA	20086	Air line assembly1
E	18414	1/2" Flat washer2	*BB	10466	Tie strap6
F	18454	3/4"-16 Nylon nut2	*CC	21230	Valve caps2
G	21837	90° Swivel elbow fitting2	*DD	18405	5/16" Flat washer2
H	01426	Clamp bar2	*EE	21234	Rubber washer2
I	10583	U-bolt2	*FF	18411	Small star washer2
J	10778	ABS sensor harness clip2	*GG	21233	5/16" Hex nut4
K	13967	Frame spacer2			
L	17106	3/8"-16 x 1.5 Bolt2			
M	17362	3/8"-16 x 5 Carriage bolt2			
N	18435	3/8"-16 Nyloc nut6			

*Not shown in fig. 1.

Installing the RideControl System

CAUTION

DO NOT INFLATE ASSEMBLY WHEN IT IS UNRESTRICTED. ASSEMBLY MUST BE RESTRICTED BY SUSPENSION OR OTHER ADEQUATE STRUCTURE. DO NOT INFLATE BEYOND 100 P.S.I. IMPROPER USE OR OVER-INFLATION MAY CAUSE ASSEMBLY TO BURST CAUSING PROPERTY DAMAGE OR SEVERE PERSONAL INJURY.

IMPORTANT: Your vehicle may be equipped with a rear brake proportioning valve. Any type of load assist product could affect brake performance. If equipped with a brake proportioning valve, we recommend that you check with your dealer before installing this type of product. If your vehicle does not have a rear brake proportioning valve or is equipped with an anti-lock type brake system, installation of a load assist product will have no effect on brake system performance.

GETTING STARTED

1. Raise the vehicle and support the axle with jack stands, setting the jack stands as wide as possible on the axle (fig. 2).
2. Remove the tires.

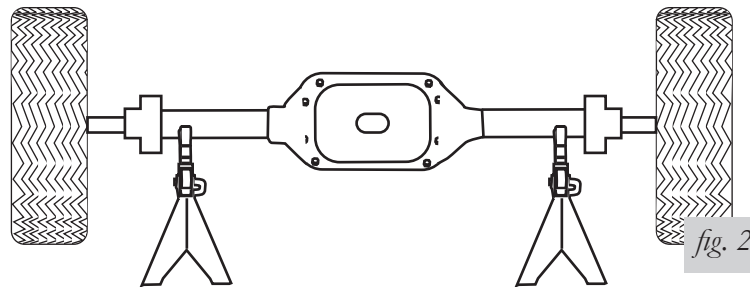

ATTACHING THE UPPER BRACKET TO THE FRAME

1. Pry the stock Anti lock Brake System (ABS) sensor harness clamp out from the bottom of the frame and remove the stock sensor harness clip from the ABS sensor harness (fig. 3).
2. Attach the supplied sensor harness clip to the sensor harness (fig. 4).
3. Disconnect the ABS sensor at the connector on top of the frame. Move the ABS sensor harness from the outside of the frame to the inside of the frame and reconnect the ABS sensor back into the wiring harness. (fig. 3 and fig. 4).

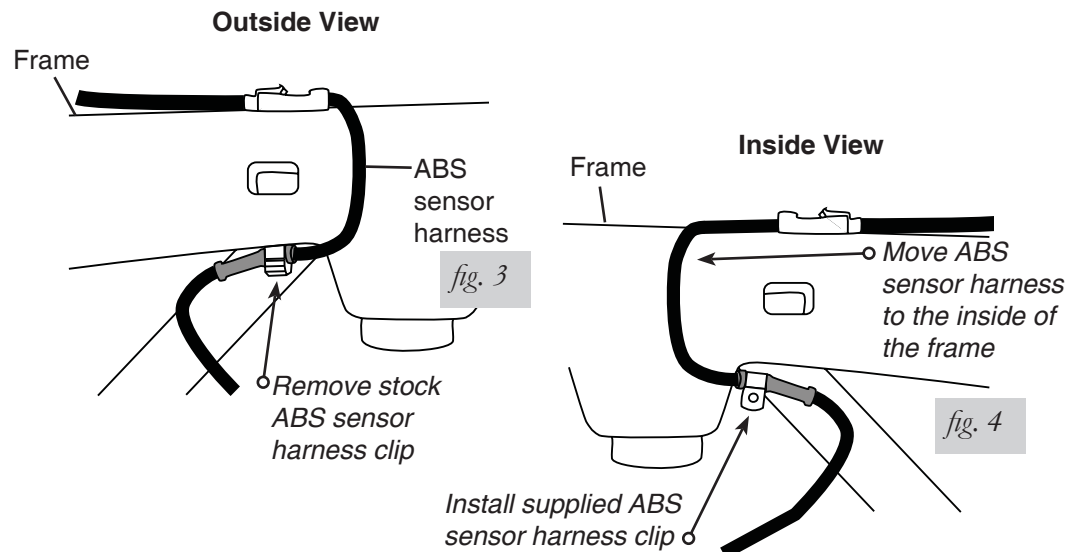

4. Insert a 3/8" bolt and medium OD washer into the frame, using the large slot behind the axle, so that the bolt extends through the bottom frame hole (fig. 5).

NOTE

This is the ABS sensor harness hole from which the stock ABS sensor harness clip was previously removed.

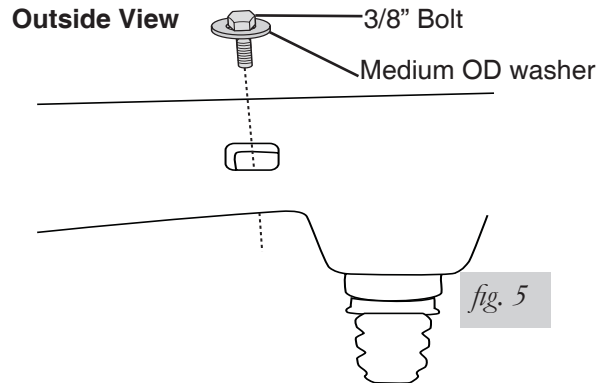

5. Attach the upper bracket to the frame behind the axle, making sure the previously inserted bolt goes through the hole on the bottom of the bracket (fig. 6).
6. Attach the brake line clip, 3/8" flat washer and nyloc nut to the bottom of the bolt. While holding the bolt and washer through the frame hole with a wrench. Torque to 44 ft/lbs (fig. 6).

CAUTION

TIGHTEN NUT WHILE KEEPING THE ABS LINE PARALLEL TO THE FRAME SO THE LINE DOES NOT RUB ON THE AIR SPRING.

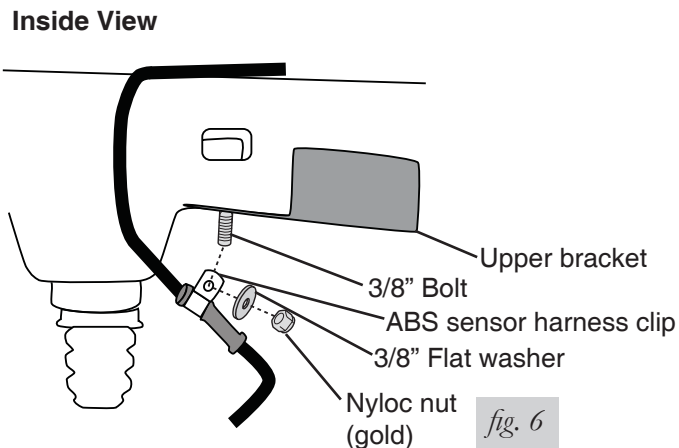

7. Insert the long 3/8" carriage bolt through the center of the upper bracket, into the frame, through a spacer, and out the back side of the frame. Attach a large OD washer and nyloc nut over the protruding bolt (fig. 7). Tighten securely.

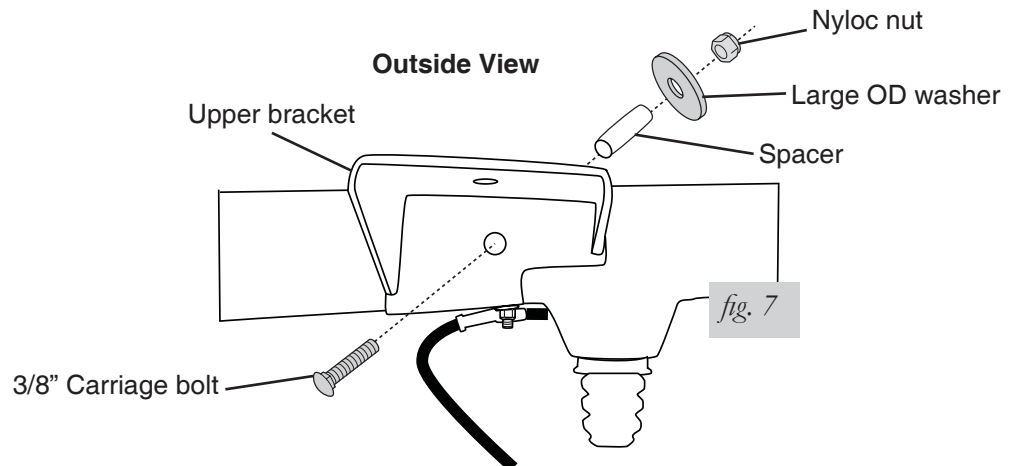

ASSEMBLING THE AIR SLEEVE

1. Install the swivel air fitting onto the air sleeve finger tight plus one and a half turns (fig. 8). Do not overtighten.
3. Attach the lower bracket to the bottom of the air sleeve with a flat washer and 1/2" bolt (fig. 8). leave loose at this time.

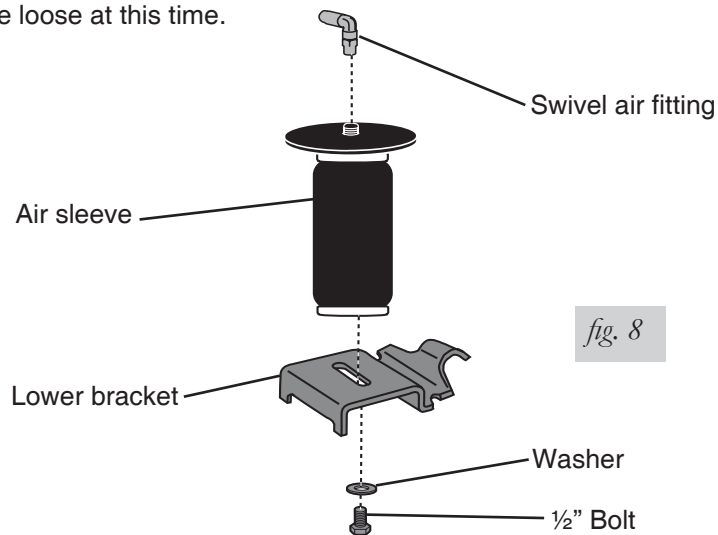

INSTALLING THE AIR ASSEMBLY

1. Attach the assembly to the upper bracket, allowing the swivel air fitting to go through the top of the bracket (fig. 9). Attach the air sleeve to the top bracket using a 3/4" nyloc nut. Tighten nut. DO NOT torque over 4 ft/lbs.
2. Set assembly onto the leaf springs so that the lip on the front side of the lower bracket hooks over the rear stock u-bolt (fig. 9).
3. Attach the supplied u-bolt over the lower bracket and leaf springs and into the clamp bar. Cap with flat washers and nyloc nuts (fig. 9). Torque to 16 ft/lbs.

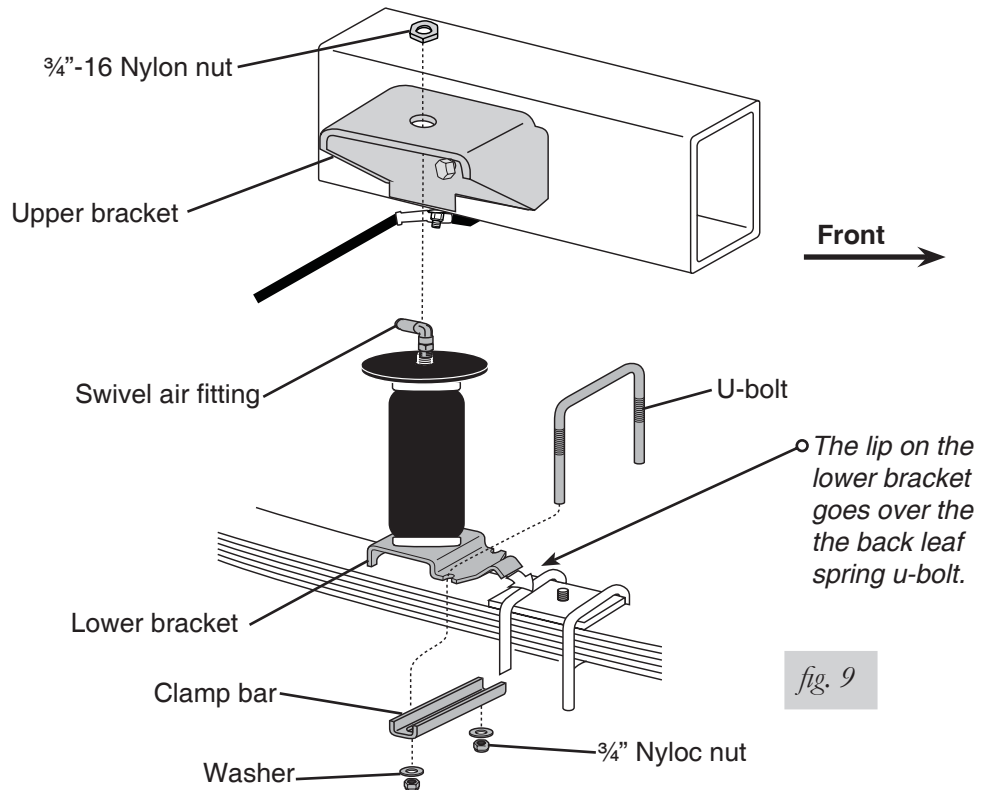

INSTALLING THE AIR LINES

1. Choose a convenient location for mounting the inflation valves. Popular locations for the inflation valve are:
 - a. The wheel well flanges
 - b. The license plate recess in bumper
 - c. Under the gas cap access door
 - d. Through the license plate

NOTE

Whatever the chosen location, make sure there is enough clearance around the inflation valves for an air chuck.

2. Drill two 5/16" holes to install the inflation valves.
3. Cut the air line assembly in two equal lengths.

CAUTION

WHEN CUTTING OR TRIMMING THE AIR LINE, USE A HOSE CUTTER, A RAZOR BLADE, OR A SHARP KNIFE. A CLEAN, SQUARE CUT WILL ENSURE AGAINST LEAKS. DO NOT USE WIRE CUTTERS OR SCISSORS TO CUT THE AIR LINE. THESE TOOLS MAY FLATTEN OR CRIMP THE AIR LINE CAUSING IT TO LEAK AROUND THE O-RING SEAL INSIDE THE ELBOW FITTING (FIG. 10).

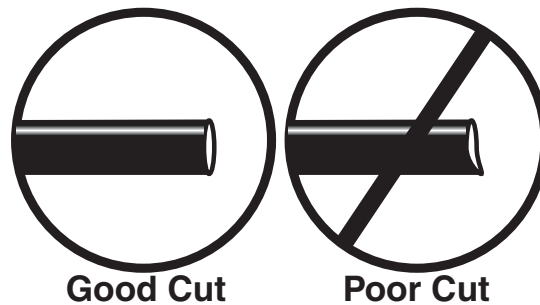

fig. 10

4. Place a 5/16" nut and star washer on the air valve. Leave enough of the inflation valve in front of the nut to extend through the hole and have room for the rubber washer, flat washer, and 5/16" nut and cap. There should be enough valve exposed after installation—approximately 1/2"—to easily apply a pressure gauge or an air chuck (fig. 11).
5. Push the inflation valve through the hole and use the rubber washer, flat washer, and another 5/16" nut to secure it in place. Tighten the nuts to secure the assembly (fig. 11).

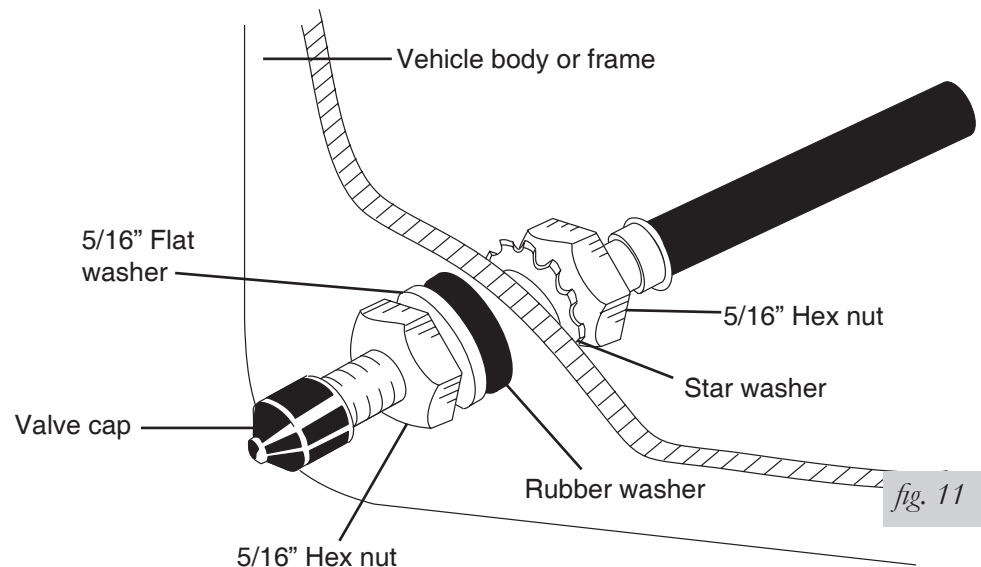
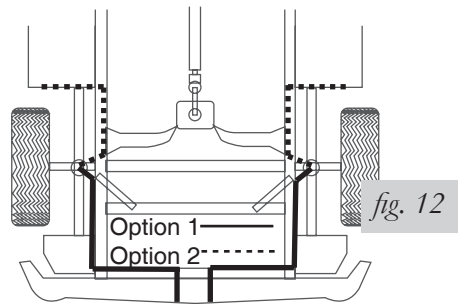

fig. 11

6. Route the air line along the frame to the air fitting on the air spring (fig. 12). Keep AT LEAST 6" of clearance between the air line and heat sources, such as the exhaust pipes, muffler, or catalytic converter. Avoid sharp bends and edges. Use the plastic tie straps to secure the air line to fixed, non-moving points along the chassis. Be sure that the tie straps are tight, but do not pinch the air line. Leave at least 2" of slack to allow for any movement that might pull on the air line.



7. Cut off the air line, leaving approximately 12" of extra air line. A clean square cut will ensure against leaks (see fig. 10). Insert the air line into the air fitting. This is a push-to-connect fitting. Simply push the air line into the 90° swivel fitting until it bottoms out (9/16" of air line should be in the fitting).
8. Repeat the installation procedure for the remaining side of the vehicle. Inflate the sleeves to 10 psi and adjust the sleeve in the lower bracket slot so the sleeve is perpendicular to the mounting brackets. Tighten the 1/2" bottom bolt securely. Reinstall tires.

CHECKING FOR LEAKS

1. Inflate the air spring to 30 p.s.i.
2. Spray all connections and the inflation valves with a solution of 1/5 liquid dish soap and 4/5 water. Spot leaks easily by looking for bubbles in the soapy water.
3. After the test, deflate the springs to the minimum pressure required to restore the system to normal ride height. Do not deflate to lower than 10 p.s.i.
4. Check the air pressure again after 24 hours. A 2 - 4 p.s.i. loss after initial installation is normal. Retest for leaks if the loss is more than 5 lbs.

FIXING LEAKS

1. If there is a problem with the swivel fitting:
 - a. Check the air line connection by deflating the spring and removing the line by pulling the collar against the fitting and pulling firmly on the air line. Trim 1" off the end of the air line. Be sure the cut is clean and square (see fig. #). Reinsert the air line into the push-to-connect fitting.
 - b. Check the threaded connection by tightening the swivel fitting another 1/2 turn. If it still leaks, deflate the air spring, remove the fitting, and re-coat the threads with thread sealant. Reinstall by hand tightening as much as possible and then use a wrench for an additional two turns.
2. If there is a problem with the inflation valve:
 - a. Check the valve core by tightening it with a valve core tool.
 - b. Check the air line by removing the air line from the barbed type fitting. Cut the air line off a few inches in front of the fitting and use a pair of pliers or vice grips to pull/twist the air line off of the fitting.

CAUTION

DO NOT CUT OFF THE AIR LINE COMPLETELY AS THIS WILL USUALLY NICK THE BARB AND RENDER THE FITTING USELESS.

3. If the preceding steps have not resolved the problem, call Air Lift customer service at (800) 248-0892.

Before Operating

INSTALLATION CHECKLIST (To be completed by installer)

- Clearance test — Inflate the air springs to 60 p.s.i. and ensure there is at least ½” clearance around each sleeve, away from anything that might rub against them. Be sure to check the tire, brake drum, frame, shock absorbers and brake cables.
- Leak test before road test — Inflate the air springs to 60 p.s.i., check all connections for leaks with a soapy water solution. See page 8 for tips on how to spot leaks. All leaks must be eliminated before the vehicle is road tested.
- Heat test — Be sure there is sufficient clearance from any heat sources — at least 6” for air springs and air lines. If a heat shield was included in the kit, install it. If there is no heat shield, but one is required, call (800) 248-0892.
- Fastener test — Recheck all bolts for proper torque.
- Road test — The vehicle should be road tested after the preceding tests. Inflate the air springs to 25 p.s.i. (50 p.s.i. if the vehicle is loaded). Drive the vehicle 10 miles and recheck for clearance, loose fasteners and air leaks.
- Operating instructions — If professionally installed, the installer should review the operating instructions on page 10 with the owner. Be sure to provide the owner with all of the paperwork which came with the kit.

Technician's Signature _____

Date _____

POST-INSTALLATION CHECKLIST (To be completed by owner)

- Overnight leakdown test — Recheck air pressure after 24 hours. If pressure has dropped more than 5 p.s.i., check for leaks and fix accordingly following the instructions on page 8 or return to the installer for service.
- Air pressure requirements — The air pressure requirements are detailed on page 10. Regardless of the load, the air pressure should always be adjusted so that normal ride height is maintained at all times.
- 30 day or 500 mile test — The air spring system must be rechecked after 30 days or 500 miles, whichever comes first. If any part shows signs of rubbing or abrasion, the source should be identified and moved, if possible. If it is not possible to relocate the cause of the abrasion, the air spring may need to be remounted. If professionally installed, the installer should be consulted. Check all fasteners for tightness.

Troubleshooting Guide

Problems maintaining air pressure, without on-board compressor.

1. Leak test the air line connections and threaded connection of the elbow into the air spring. See "Fixing Leaks" to repair.
2. Leak test the inflation valve for leaks at the air line connection or dirt or debris in the valve core. See "Fixing Leaks" to repair.
3. Inspect the air line to be sure it is not pinched. Replace leaking components.
4. Inspect air line for holes and cracks. Replace as needed.
5. A kink or fold in the air line. Reroute as needed.
6. At this point the problem is most likely a failed air spring - either a factory defect or an operating problem. Please call Air Lift at (800) 248-0892 for assistance or a replacement air spring.

Maintenance and Servicing

Minimum Air Pressure	Maximum Air Pressure
10 p.s.i.	100 p.s.i.
FAILURE TO MAINTAIN CORRECT MINIMUM PRESSURE (OR PRESSURE PROPORTIONAL TO LOAD), BOTTOMING OUT, OVER-EXTENSION OR RUBBING AGAINST ANOTHER COMPONENT WILL VOID THE WARRANTY.	

By following these steps, vehicle owners will obtain the longest life and best results from their air springs.

1. Inflate your air springs to 60 p.s.i. before adding the payload. After the vehicle is loaded, adjust your air pressure to level the vehicle and for ride comfort.
2. Check the air pressure weekly.
3. Always maintain normal ride height. Never inflate beyond 100 p.s.i.
4. If you develop an air leak in the system, use a soapy water solution of 1/5 liquid dish soap and 4/5 water. to check all air line connections and the inflation valve core before deflating and removing the air spring.
5. When increasing load, always adjust the air pressure to maintain the normal ride height. Increase or decrease pressure from the system as necessary to attain normal ride height for optimal ride and handling. Remember that loads carried behind the axle (including tongue loads) require more leveling force (pressure) than those carried directly over the axle.

CAUTION

FOR YOUR SAFETY AND TO PREVENT POSSIBLE DAMAGE TO YOUR VEHICLE, DO NOT EXCEED MAXIMUM GROSS VEHICLE WEIGHT RATING (GVWR), AS INDICATED BY THE VEHICLE MANUFACTURER. ALTHOUGH YOUR AIR SPRINGS ARE RATED AT A MAXIMUM INFLATION PRESSURE OF 100 P.S.I. THE AIR PRESSURE ACTUALLY NEEDED IS DEPENDANT ON YOUR LOAD AND GVWR, WHICH MAY BE LESS THAN 100 P.S.I. CHECK YOUR VEHICLE OWNERS MANUAL AND DO NOT EXCEED THE MAXIMUM LOAD LISTED FOR YOUR VEHICLE.

6. Always add air to springs in small quantities, checking the pressure frequently. Sleeves require less air volume than a tire and inflate quickly.
7. Should it become necessary to raise the vehicle by the frame, make sure the system is at minimum pressure (10 p.s.i.) to reduce the tension on the suspension/brake components. Use of on board leveling systems do not require deflation or disconnection.

Warranty and Returns Policy

Air Lift Company warrants its products for the time periods listed below to the original retail purchaser against manufacturing defects used on catalog listed applications on cars, vans, light trucks and motorhomes under normal operating conditions for as long as Air Lift manufactures the product. The warranty does not apply to products that have been improperly applied, installed, used in racing applications or not maintained in accordance with installation instructions furnished with all Air Lift products. The consumer will be responsible for removing (labor charges) the defective product from the vehicle and returning it, transportation costs prepaid to the dealer from which it was purchased or to Air Lift Company for verification.

Air Lift will repair or replace, at its option, defective products or components. A \$10.00 shipping and handling charge will apply to all warranty claims. Before returning any defective product, you must call Air Lift (800) 248-0892 U.S. and Canada for a Returned Materials Authorization (RMA) number. Returns to Air Lift can be sent to: Air Lift Company • 2727 Snow Road • Lansing, MI • 48917.

Product failures resulting from abnormal use or misuse are excluded from this warranty. The loss of use of the product, loss of time, inconvenience, commercial loss or consequential damages is not covered. The consumer is responsible for installation/reinstallation (labor charges) of the product. Air Lift Company reserves the right to change the design of any product without assuming any obligation to modify any product previously manufactured.

This warranty gives you specific legal rights and you may also have other rights that may vary from state to state. Some states do not allow limitations on how long an implied warranty lasts or allow the exclusion or limitation of incidental or consequential damages. The above limitation or exclusion may not apply to you. There are no warranties, expressed or implied including any implied warranties of merchantability and fitness, which extend beyond this warranty period. There are no warranties that extend beyond the description on the face hereof. Seller disclaims the implied warranty of merchantability. *(Dated proof of purchase required.)*

Air Lift 1000*	2 Year Limited	RideControl Plus*	2 Year Limited
SureSet*	2 Year Limited	Load Controller (I)*	2 Year Limited
SuperDuty*	2 Year Limited	SmartAir*	2 Year Limited
Other Accessories	2 Year Limited	Load Controller (II)*	2 Year Limited
RideControl*	2 Year Limited	EasyStreet Systems	1 Year Limited
SlamAir	2 Year Limited	RoadTamer Systems	2 Year Limited

**The purchase of an Air Lift Load Controller II, SmartAir Automatic Leveling System or SureSet Load Controller System with a Super Duty, Ride Control, or Air Lift 1000 extends the air springs' warranty from two years to a Limited Lifetime Warranty to the original purchaser of the covered systems. All other above listed warranty requirements will apply. (RoadTamer and EasyStreet air spring systems are excluded from this offer.)*

Replacement Information

If you need replacement parts, contact the local dealer or call Air Lift customer service at (800) 248-0892. Most parts are immediately available and can be shipped the same day.

Contact Air Lift Company customer service at (800) 248-0892 first if:

- Parts are missing from the kit.
- Need technical assistance on installation or operation.
- Broken or defective parts in the kit.
- Wrong parts in the kit.
- Have a warranty claim or question.

Contact the retailer where the kit was purchased:

- If it is necessary to return or exchange the kit for any reason.
- If there is a problem with shipping if shipped from the retailer.
- If there is a problem with the price.

Contact Information

If you have any questions, comments or need technical assistance contact our customer service department by calling (800) 248-0892, Monday through Friday, 8 a.m. to 5 p.m. Eastern Time. For calls from outside the USA or Canada, our local number is (517) 322-2144.

For inquiries by mail, our address is PO Box 80167, Lansing, MI 48908-0167. Our shipping address for returns is 2727 Snow Road, Lansing, MI 48917.

You may also contact us anytime by e-mail at sales@airliftcompany.com or on the web at www.airliftcompany.com.

Need Help?

Contact our customer service department by calling (800) 248-0892, Monday through Friday, 8 a.m. to 5 p.m. Eastern Time. For calls from outside the USA or Canada, our local number is (517) 322-2144.

**Register your warranty online at
www.airliftcompany.com/warrantyreg.htm**



Thank you for purchasing Air Lift products — the professional installer's choice!

Air Lift Company • 2727 Snow Road • Lansing, MI 48917 or PO Box 80167 • Lansing, MI 48908-0167
Toll Free (800) 248-0892 • Local (517) 322-2144 • Fax (517) 322-0240 • www.airliftcompany.com

Printed in
the USA