

Kit No. 57250/57252

www.airliftcompany.com

Please read these instructions completely before proceeding with installation



IMPORTANT: The 57250/57252 kit has been designed to fit the Chevrolet 1500 HD and standard 2500 (not HD) models only. The 57250/57252 kit has not been designed to fit any standard duty 1500 models. This kit should not be used for these applications.

Assembly
Figure 1

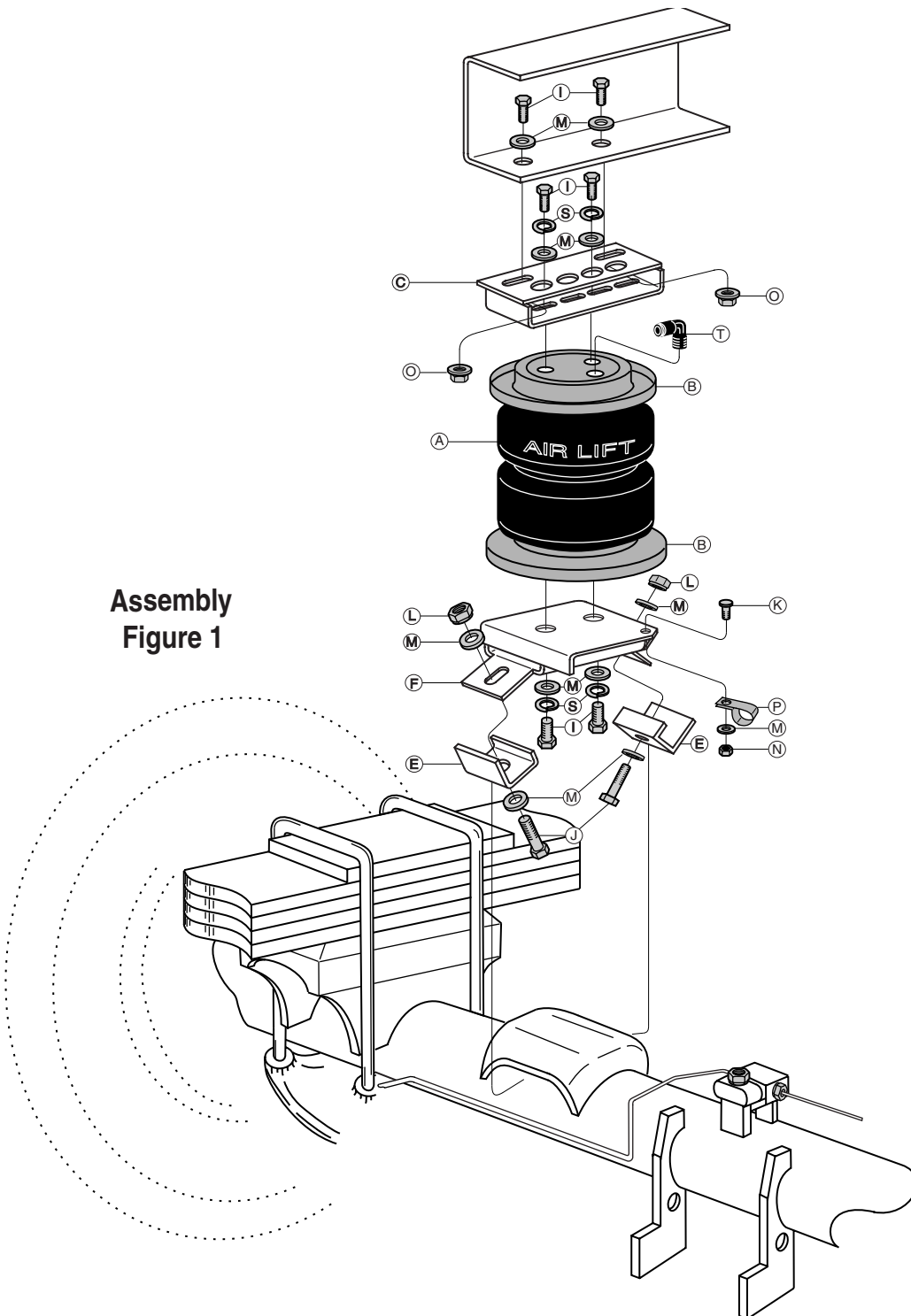



Item	Description	Quantity
A	Air Springs	2
B	Roll Plates	4
C	Upper Bracket	2
E	Retaining Brackets	4
F	Lower Brackets	2
G	Heat Shield Kit	1
I	3/8" x 7/8" Hex Head Bolts	12
J	3/8" x 2" Hex Head Bolts	4
K	5/16" Clinch Bolt (Driver's Side Only)	1
L	3/8" Lock Nut	4
M	Flat Washer	21
N	5/16" Lock Nut (Driver's Side Only)	1
O	3/8" Whiz Nut	4
P	Hose Clip (Driver's Side Only)	1
S	Lock Washers	8
T	90° Swivel Fitting	2
AA	Air Line Assembly	1
BB	Tie Strap	6
CC	Valve Caps	2
DD	5/16" Flat Washers	2
EE	Rubber Washer	2
FF	Star Washer	2
GG	5/16" Hex Nut	4
HH	Thermal Sleeve	2



Tools Needed

9/16" open-end or box wrenches
Ratchet with 15mm, 7/16", 9/16"
and 1/2" deep well sockets
3/8" and 5/16" drill bits (very sharp)
Heavy Duty Drill
Torque Wrench

Hose Cutter, Razor Blade, or Sharp
Knife
Hoist or Floor Jacks
Safety Stands
Safety Glasses
Air Compressor, or Compressed Air
Source
Spray Bottle with Dish Soap/Water
Solution

Before You Start

You need to determine Normal Ride Height. Normal Ride Height is the distance between the bottom edge of the wheel well and the center of the hub with the vehicle in the "as delivered" condition. In some cases, Normal Ride Height is not perfectly level.



TRUCK

Remove unusual loads and examine your vehicle from the side to ensure it is on a level surface. If necessary (in cases where your leaf springs are sagging badly), use a jack to raise the rear end so that the vehicle achieves the original "as delivered" ride height.



MEASUREMENT

Measure the distance between the center of the hub and the bottom edge of the wheel well. This is the Normal Ride Height. Enter the measurement below:

**NORMAL
RIDE HEIGHT:** _____ inches

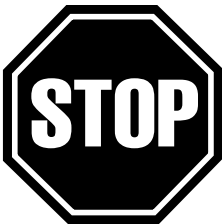

IMPORTANT: *Your vehicle may be equipped with a rear brake proportioning valve. Any type of load assist product could affect brake performance. We recommend that you check with your dealer before installing this type of product. If your vehicle DOES NOT have a rear brake proportioning valve or is equipped with an anti-lock type brake system, installation of a load assist product will have NO EFFECT ON BRAKE SYSTEM PERFORMANCE.*



CAUTION: *Compressed air can cause injury and damage to the vehicle and components if it is not handled properly. For your safety, do not try to inflate the air springs until they have been properly secured to the vehicle.*



Assembling the Air Spring Unit

Set a roll plate (B) on both ends of the air spring (A). The radiused (rounded) edge of the roll plate will be towards the air spring, so that the air spring is “seated” in both roll plates (Fig. 4).

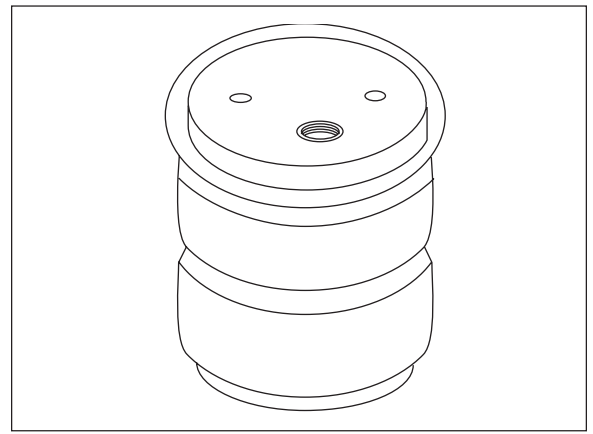

Fig. 4

Attach the upper brackets (C) to the air springs with two 3/8-24x7/8” hex head bolts (I), lockwashers (S) and flat washers (M). Leave loose at this time (Fig. 5).

Note: It will be necessary to use the correct holes for driver and passenger side mounting. See diagram to correctly index the bellows and the upper bracket (Fig. 6).

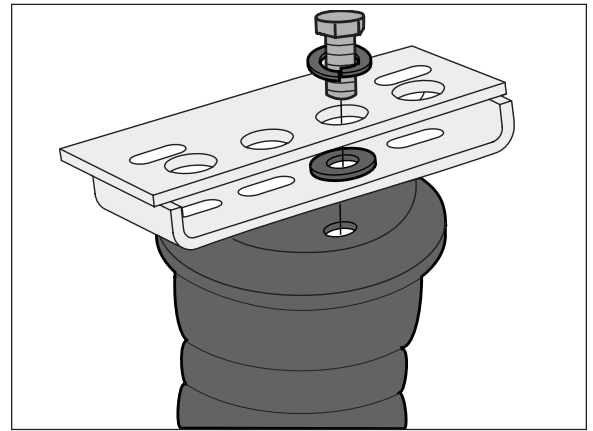

Fig. 5

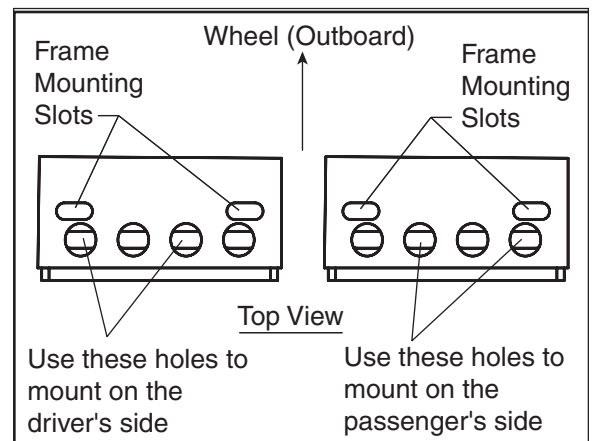

Fig. 6

DRIVERS SIDE ONLY - Insert 5/16 clinch bolt (K) into the small hole of the lower bracket before attaching the lower bracket to the air spring. Supporting the lower bracket will ease installation of the clinch bolt. Use a hammer to drive the bolt into the hole in the lower bracket (Fig. 7).

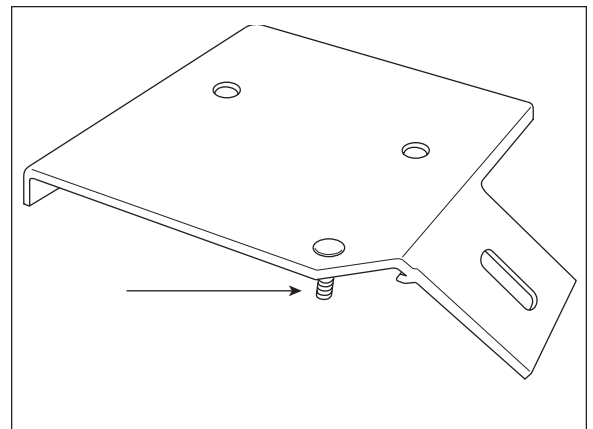
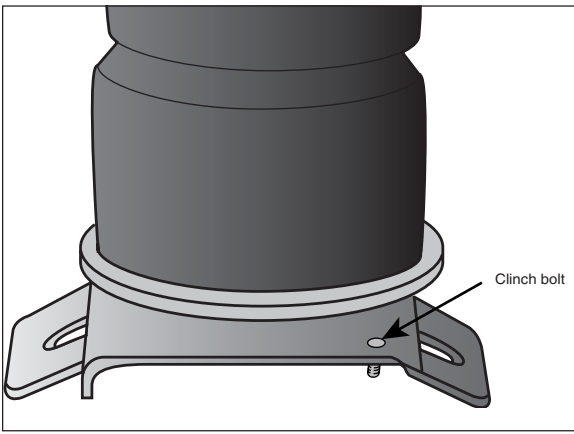
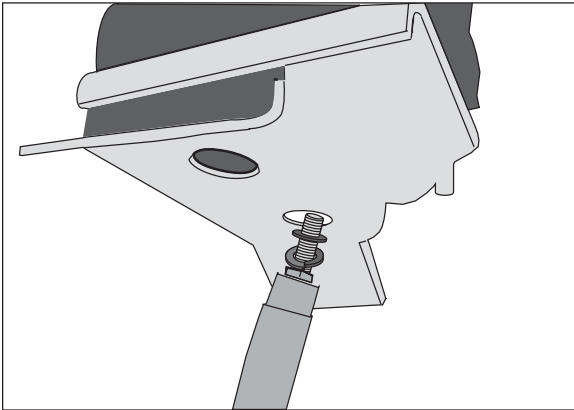

Fig. 7



The lower bracket must be attached with the small hole in the lower bracket on the same side as the air port in the air spring.

Note: Be sure to install the assembly with the clinch bolt on the driver side. Refer to diagram (Fig. 7) on page 4.



Attach the air spring to the lower bracket. Secure the lower bracket (F) to the air spring (A) with two 3/8-16x7/8" hex head bolts (I), lockwashers (S) and flat washers (M).

Torque to 20 ft. lbs. It may be helpful to use a socket to install the mounting hardware.

CAUTION-Do not cross thread the bolt.

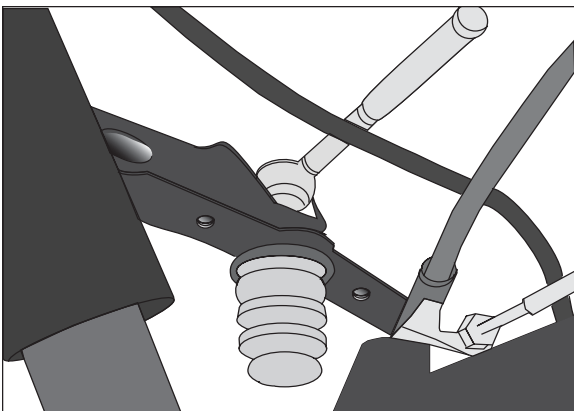

Removing Jounce Bumper

Using a 15mm Socket, remove the jounce bumper from the frame rail (Fig. 10).

The style of jounce bumper will vary depending on the model of the truck.



On some models the jounce bumper may be attached to the frame with a bracket.

Remove the entire jounce bumper bracket and the jounce bumper from the frame rail (Fig. 11).

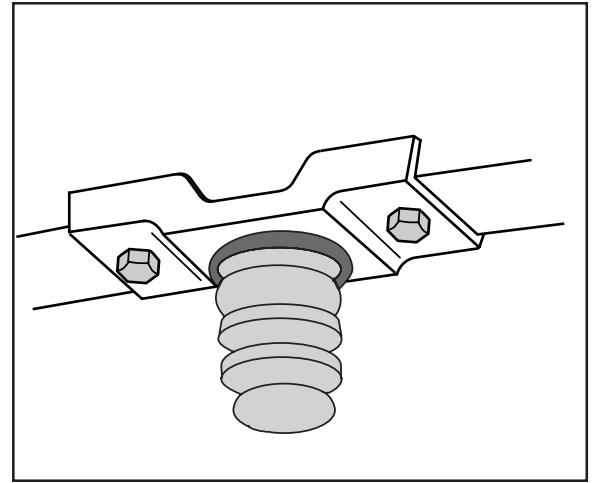

11

Attaching the Air Spring Assembly

Set assembly on the axle with the air port on top of the bellows toward the inside of the frame rail (Figure 1).

Note: Reference Assembling the Air Spring Unit (page 4), Attaching the Upper Bracket, for driver side and passenger side assemblies.

Set whiz nut (O) up inside of the upper bracket (Fig. 12 & 13) with flange up (Fig. 12).

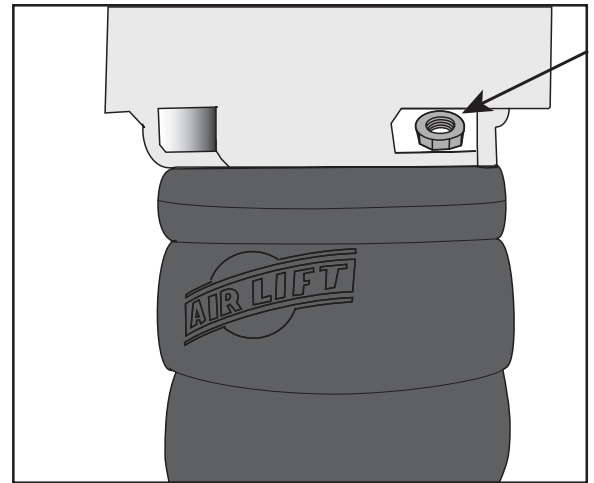

12

Hold in place with an open end 9/16" wrench.

Put 3/8"x7/8" hex head bolts (I) with flat washers (M) down through the existing jounce bumper hole from the inside of the frame, and attach to the whiz nuts (Fig. 13). Leave loose for adjustment later.

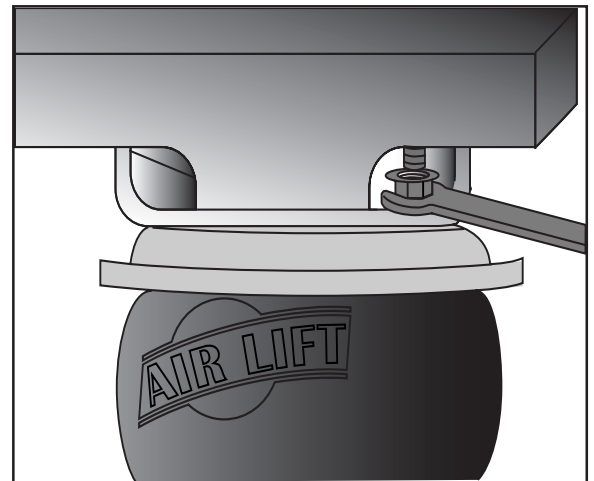

13



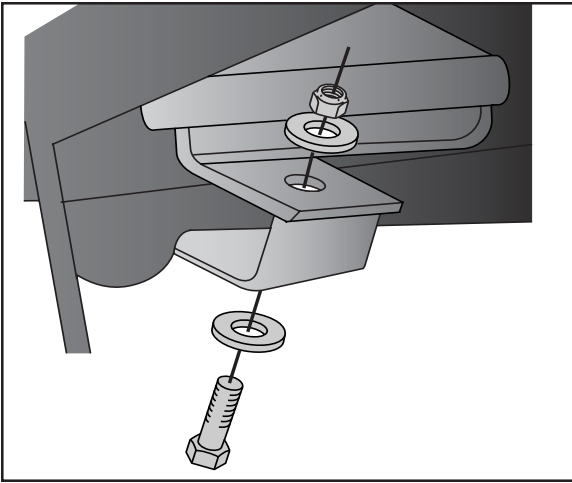

11

Secure the lower bracket to the jounce bumper strike pad using the retaining bracket (E), 3/8"x2" hex head bolt (J), flat washers (M) and 3/8" lock nut (L) (Fig. 14).

The short leg of the retaining bracket must be under the edge of the jounce bumper strike pad.

Tighten evenly front to back to keep the lower bracket flat and centered on the jounce bumper pad.

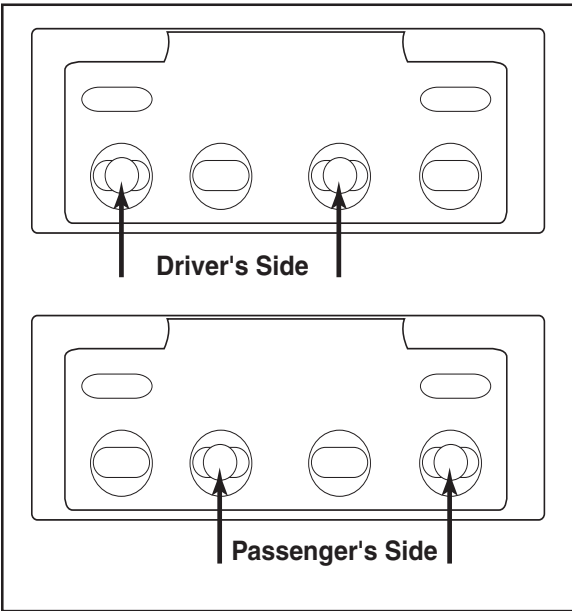

12

Center the upper bracket, so the bolts are in the center of the slots (Fig. 15).

Adjust bellows at top so bellows is perpendicular to both upper and lower brackets.

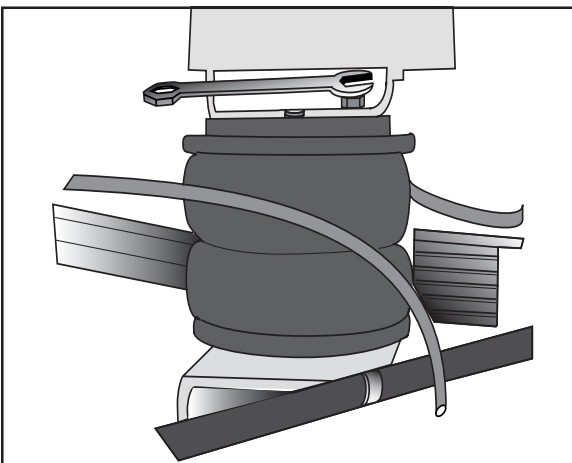

13

Tighten both bellows to top bracket mounting bolts (Fig. 16).

Tighten bracket to frame mounting hardware.



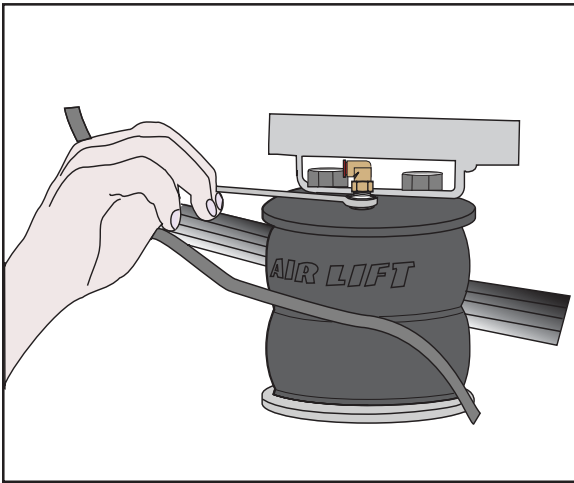

Install the swivel air fitting (T) into the top of the air spring (A). This fitting is pre-coated with sealant. Fingertight plus two full turns with an open-end wrench will seal the fitting (Fig. 17).

Use a 7/16" open end wrench being careful to tighten on the metal hex nut only.

DO NOT OVERTIGHTEN.



DRIVERS SIDE ONLY - Secure Brake Line

Slide the provided clip (P) onto the rubber coated brake line (Fig. 18). Secure the clip (P) to the clinch bolt already installed on the lower bracket (F) with a flat washer (M) and 5/16" nut (N).

BE SURE THE CLIP IS UNDER THE LOWER BRACKET.

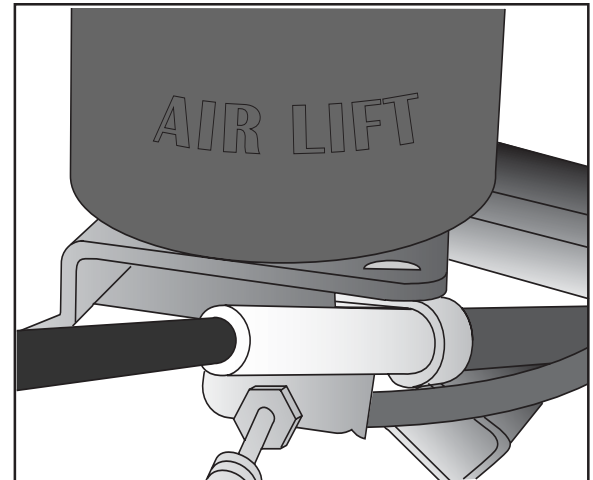
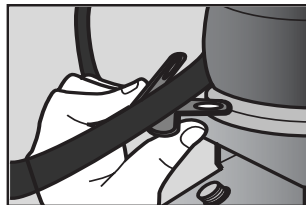

Install the Other Air Spring

You have now completed the installation for one air spring. Repeat the steps on pages 4 through 8 for the other side of the vehicle before you proceed to page 9.

Installing the Air Lines

Choose a convenient location for mounting the inflation valves. Make sure there is enough clearance around the inflation valves for an air chuck. Drill a 5/16" hole to install the inflation valves.

Recommended location is in the wheel well, license plate area or lower body ahead of rear wheel. One on each side provides ease of filling, checking and measuring body height to compensate for side to side lean and sag.

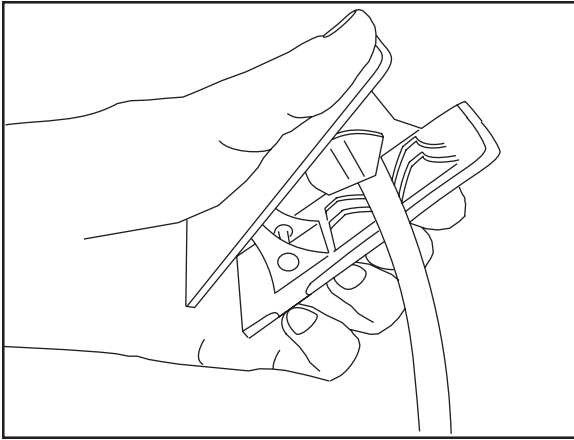

Cut the air line assembly (AA) in two equal lengths (Fig. 20).

When cutting or trimming the air line, use a hose cutter (Air Lift P/N 10530), a razor blade or a sharp knife. A clean, square cut will ensure against leaks (Fig. 21).

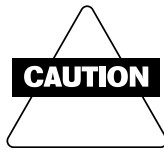

Do not use wire cutters or scissors to cut the air line. These tools may flatten or crimp the air line, causing it to leak around the O-ring seal inside the elbow fitting (Fig. 22).

Good cut - clean and square

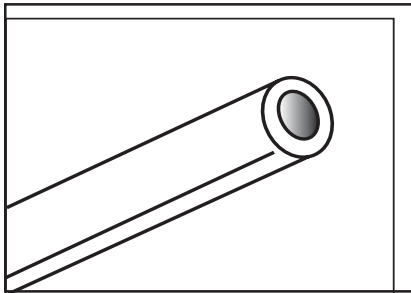

Bad cut - flattened

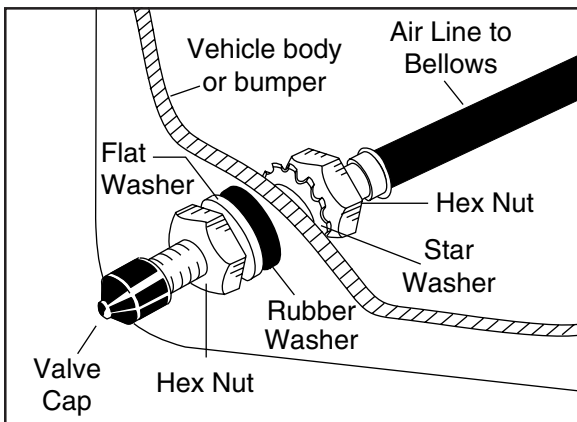
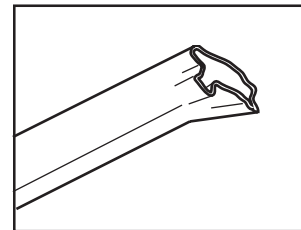

Place a 5/16" nut (GG) and a star washer (FF) on the air valve. Leave enough of the inflation valve in front of the nut to extend through the hole and have room for the rubber washer (EE), flat washer (DD), and 5/16" nut (GG) and cap (CC). There should be enough valve exposed after installation - approximately 1/2" - to easily apply a pressure gauge or an air chuck (Fig. 23).



Route the air line along the frame to the air spring location on the leaf spring, behind the axle. Keep at least 6" of clearance between the air line and heat sources, such as the exhaust pipes, muffler, or catalytic converter.

Avoid sharp bends and edges.

Use the plastic tie straps (BB) to secure the air line to fixed, non-moving points along the chassis. Be sure that the tie straps are tight, but do not pinch the air line.

Leave at least 2" of slack to allow for any movement that might pull on the air line.

PASSENGER SIDE ONLY - Before installing the air line, place a thermal sleeve (HH) on the air line near the exhaust.

Trim the excess air line before inserting it into the air fitting.
Using a standard tube cutter, a razor blade, or very sharp knife to cut the air line. Cut off air line leaving approximately 12 inches of extra air line.
A clean square cut will ensure against leaks (Fig. 21).

Insert the air line into the air fitting (Fig. 24). This is a push to connect fitting. Simply push the air line into the fitting until it bottoms out (**9/16" of air line should be in the fitting**).

Maintain a smooth bend from the air spring.

Do not kink the air line.

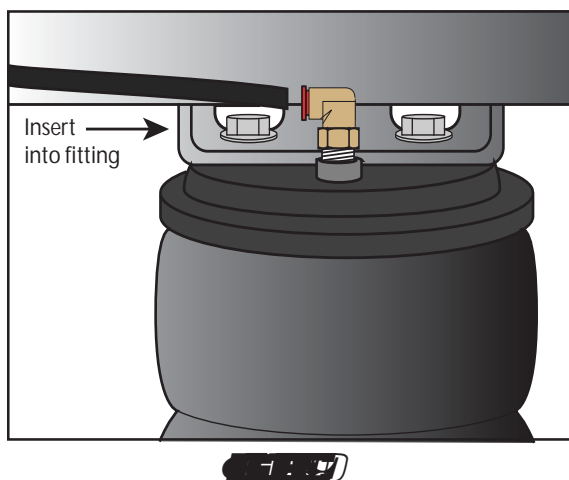

Installing Heat Shield



Bend tabs to provide a 1/2" dead air space between exhaust pipe and heat shield (Fig.25).

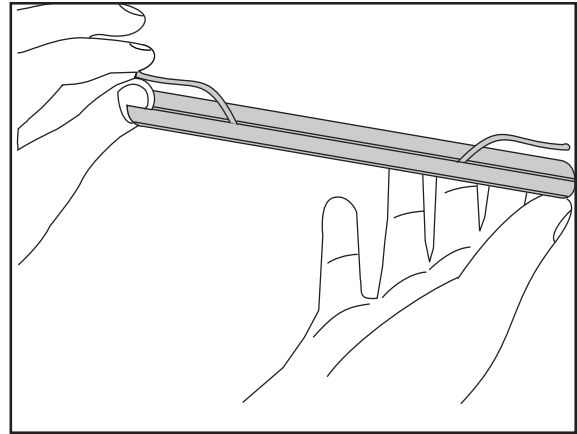

Attach the heat shield (G) to the exhaust pipe using the provided clamps. Bend the heat shield for maximum clearance to the air spring (Fig. 26).

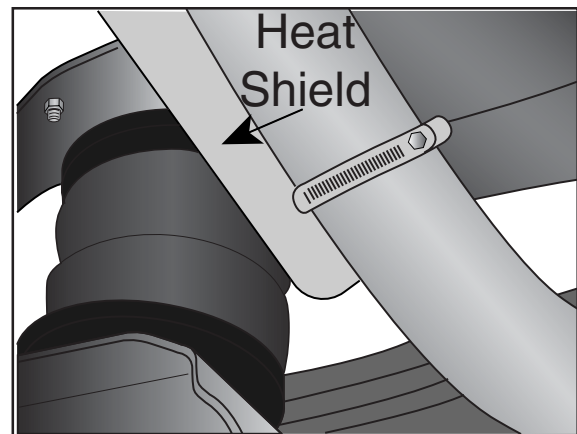

Inflation Decal

Install the minimum/maximum air pressure decal in a highly visible location. We suggest placing it on the driver's side window, just above the door handle.



Checking for Leaks

Inflate the air spring to 60 p.s.i.. Spray all connections and the inflation valves with a solution of 1/3 dish soap and 2/3 water to check for leaks. You should be able to spot leaks easily by looking for bubbles in the soapy water. After the tests, deflate the springs to the minimum pressure required to restore the Normal Ride Height, but do not go below 5 p.s.i.



Check the air pressure again after 24 hours. A 2 to 4 p.s.i. loss after initial installation is normal. Retest for leaks if the loss is more than 5 lbs.

Fixing Leaks

Air Line Connection

Deflate the spring and remove the line by pushing the collar against the fitting and pulling the air line straight out. Trim 1" off the end of the air line. Be sure the cut is clean and square. Reinsert the air line into the push to connect fitting.

Inflation Valve

1. Valve Core

Tighten the valve core with a valve core tool.

2. Air Line Connection

When removing air line from a barbed type fitting, **DO NOT CUT IT OFF** as this will usually nick the barb and render the fitting useless. Cut air line off a few inches in front of the fitting and use a pair of pliers or vise-grips to pull/twist the air line off the fitting.

If the preceding steps have not resolved the problem, call Air Lift Technical Service at 1-800-248-0892 for assistance.

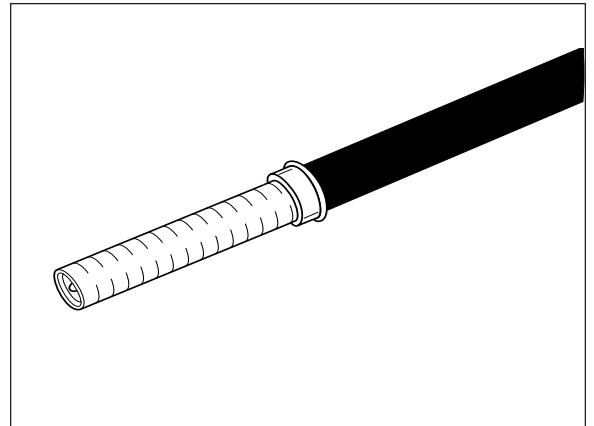

Checklist

You can protect your warranty on this product and prevent unnecessary wear by ensuring the following checks have been made:

Section I - Installation (To be completed by the installer).

- _____ 1. Clearance Test - Inflate the air springs to 60 p.s.i. and ensure there is at least 1/2" clearance around each air spring from anything that might rub against them. Be sure to check the tire, brake drum, frame, shock absorbers and brake cables.
- _____ 2. Leak Test Before Road Test - Inflate the air springs to 60 p.s.i., check all connections for leaks with a soapy water solution. See page 15 of the manual for tips on how to spot leaks. All leaks must be eliminated before the vehicle is road tested.
- _____ 3. Heat Test - Be sure there is sufficient clearance from heat sources - at least 6" for air springs and air lines.
- _____ 4. Fastener Test - Recheck all bolts for proper torque.

Torque Guide:

All Attaching Hardware 20 ft.lbs.

- _____ 5. Road Test - The vehicle should be road tested after the preceding tests. Inflate the springs to 25 p.s.i. (50 p.s.i. if the vehicle is loaded). Drive the vehicle 10 miles and recheck for clearance, loose fasteners and/or air leaks.
- _____ 6. Operating Instructions - If professionally installed, the installer should review the operating instructions on page 14 with the owner. Be sure to provide the owner with all of the paperwork that came with the kit.

Section II - Post Installation Checklist (TO BE COMPLETED BY OWNER)

- _____ 1. Overnight Leakdown Test - Recheck air pressure after vehicle has been used for 24 hours. If pressure has dropped more than 5 p.s.i., you have a leak that must be fixed. Either fix the leak yourself (see page 15) or return to the installer for service.
- _____ 2. Air Pressure Requirements - I understand that the air pressure requirements of my air spring system are as follows:

Minimum _____ Maximum _____

I also understand that I must inflate the air springs until the Normal Ride Height measurement that was recorded on page 2 has been restored. **Regardless of load, the air pressure should always be adjusted so that the Normal Ride Height is maintained at all times.**

- _____ 3. Thirty Day or 500 Mile Test. I understand that I must recheck the air spring system after 30 days or 500 miles, whichever comes first. If any part shows signs of rubbing or abrasion, the source should be identified and moved, if possible. If it is not possible to relocate the cause of the abrasion, the air spring may need to be remounted. If professionally installed, the installer should be consulted. Check all fasteners for tightness.



Air Pressure Requirements

MAXIMUM AIR PRESSURE

Loaded or Unloaded Vehicles ----- 100 PSI

Do not exceed the maximum Gross Vehicle Weight Rating (GVWR) as specified by the vehicle manufacturer. The GVWR will be found in either the Owner's Manual or the Specification Plate on the driver's side inside door jamb. It is important to understand that air springs do not increase the GVWR of your vehicle. The GVWR is determined by tires, wheels, axles, suspension and driveline. The purpose of air springs is to keep the vehicle level and balanced, which by doing so improves ride and handling for a vehicle, whether loaded or unloaded. Operating your vehicle in excess of the GVWR will void the Air Lift Limited Warranty.

MINIMUM AIR PRESSURE

Unloaded Vehicles -----5 PSI or More

An "Unloaded Vehicle" typically means a vehicle with the driver and passengers and a full fuel tank. Your factory suspension should be adequate to support this type of load. The 5 psi in the air springs is a minimum air pressure to maintain the shape of the bellows when the vehicle is unloaded. This will prevent damage to the air springs from bottoming out and pinching over big bumps and dips in the road (e.g. railroad tracks, chuckholes, speed bumps, etc.). If your vehicle is older with a worn, sagging suspension, you will need more than 5 psi to raise the vehicle to the normal ride height. A general guideline is to use enough air pressure to raise the vehicle to the desired ride height without making the ride rough or bouncy.

Loaded Vehicles ----- 25 PSI or More

A "Loaded Vehicle" means a vehicle with a heavy bed load, a trailer, or both. As discussed above under maximum pressure, never exceed the vehicle manufacturer's GVWR, regardless of air spring air pressure or other load assist. The air springs in your kit will support approximately 40 pounds of load (combined for both springs) for each 1 psi of air pressure. The following chart can be used as a general guide for operating air pressure:

<u>Load</u>	<u>Air Pressure</u>
1000 lbs	25-35 psi
2000 lbs	45-55 psi
3000 lbs	70-80 psi
4000 lbs	90-100 psi

Again, the above chart is a general guideline, use enough pressure to level your vehicle to the regular factory ride height. The required air pressure will vary depending on the state of the original suspension. Operating the vehicle below the recommended minimum air spring pressures may void your Air Lift Limited Warranty.

Tips and Techniques

1. **ADDING AIR** - Always add air to the air springs in small quantities. The volume of air in an air spring is small in relation to a tire. Too much air, too quickly can overinflate and damage the air spring.
2. **PERIODIC CHECKING OF AIR PRESSURE** - Check the pressure in your air springs weekly or prior to driving the vehicle if it has been in storage for a month or more. The number one cause of air spring failure is driving the vehicle with too low of air pressure.
3. **FRAME CONTACT HOIST** - Prior to lifting the vehicle on a frame contact hoist where the suspension hangs free, reduce your air spring air pressure to 5 psi to reduce the tension on the suspension components.
4. **RIDE COMFORT** - If the rear of the vehicle is stiff or bouncy, reduce the air pressure in 5 psi increments to smooth the ride. If the ride is choppy or the vehicle bottoms out on bumps and dips, increase the air pressure in 5 psi increments until the ride is smooth or the bottoming stops.
5. **FASTENER CHECK** - Periodically check all of the air spring system fasteners for tightness. Also check your air spring for any signs of rubbing and realign to eliminate rubbing if necessary.
6. **CLEAN UP** - Give your air springs a good hard spray with a garden hose periodically to remove mud, sand, gravel or other abrasive debris



Troubleshooting Guide

1. Problems maintaining air pressure

WITHOUT ON-BOARD COMPRESSOR



Leak test the air line connections and threaded connection of the elbow into the air spring. See page 12 to repair.



Leak test the inflation valve for leaks at the air line connection or dirt or debris in the valve core. See page 12 for repair.

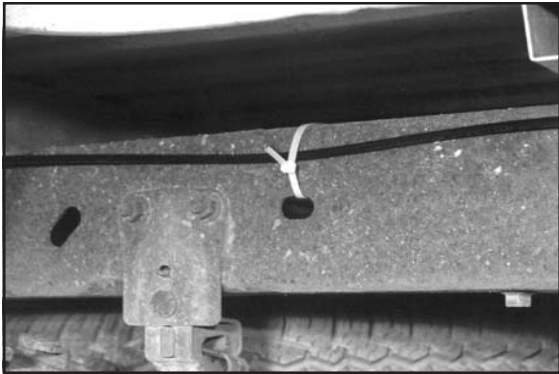

Inspect air lines to be sure it is not pinched. Tie straps may be too tight. Loosen or replace strap. Replace leaking components.

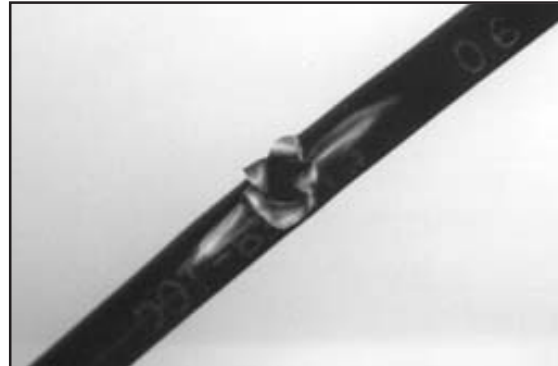

Inspect air line for holes and cracks. Replace as needed.



A kink or fold in the air line. Re-route as needed.

You have now tested for all of the most probable leak conditions that can be easily fixed. At this point the problem is most likely a failed air spring - either a factory defect or an operating problem. We suggest that you return the vehicle to your installer. If self-installed or you are the professional installer, please call Air Lift at 1-800-248-0892 for assistance or a replacement air spring.



Notes

You may find this space useful for recording information about your system (i.e. weekly pressure readings). Also record any information from your installer or Air Lift technical assistance personnel.



Thank you for purchasing Air Lift Products

Mailing Address:
AIR LIFT COMPANY
P.O. Box 80167
Lansing, MI 48908-0167

Street Address:
AIR LIFT COMPANY
2727 Snow Rd.
Lansing, MI 48917

Local Phone: (517) 322-2144

Fax: (517) 322-0240

For Technical Assistance call 1-800-248-0892

"The Choice of the Professional Installer"

