

DIRECTION 436

HOW TO INSTALL A U-BOLT

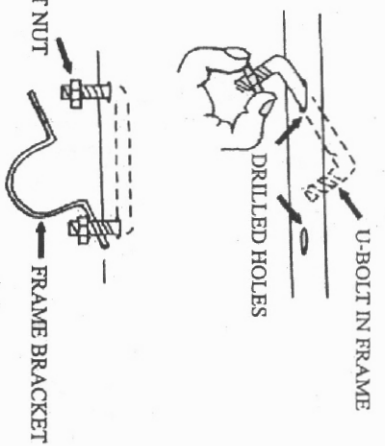

END-LINK ASSEMBLY

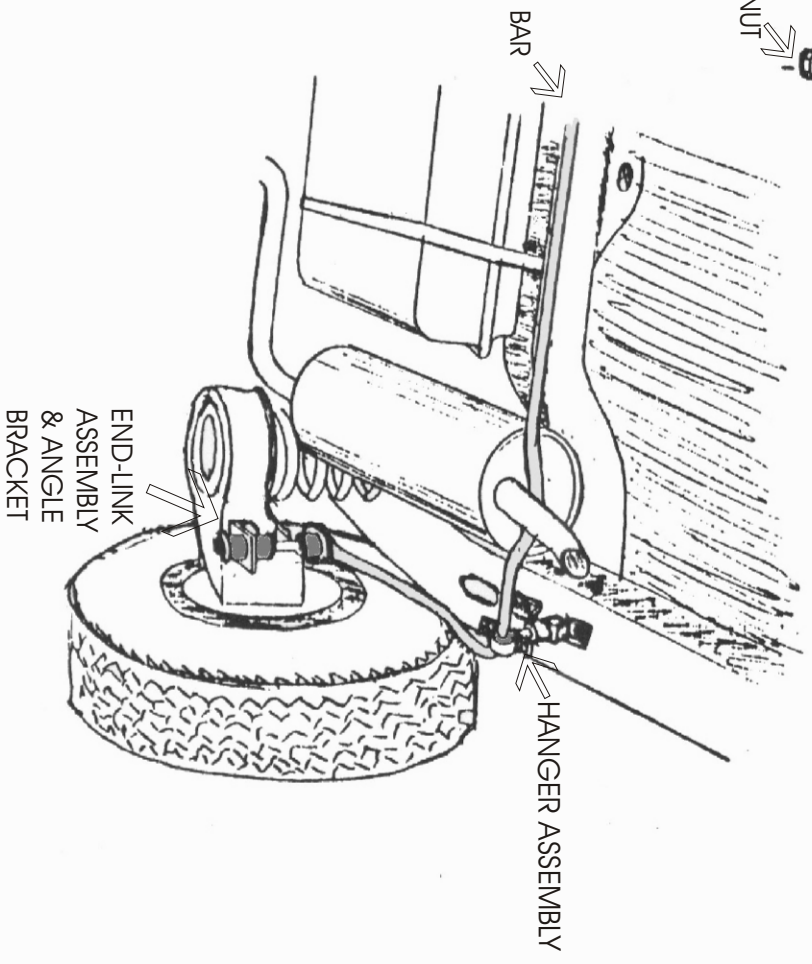
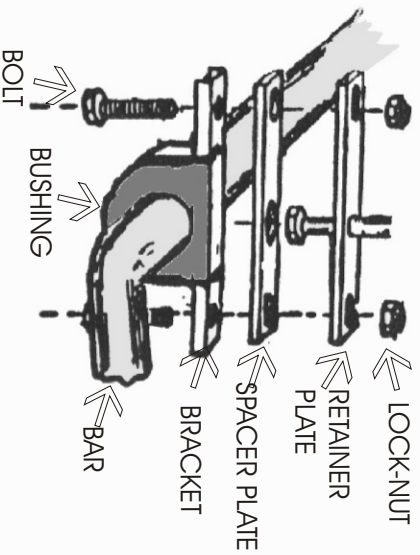
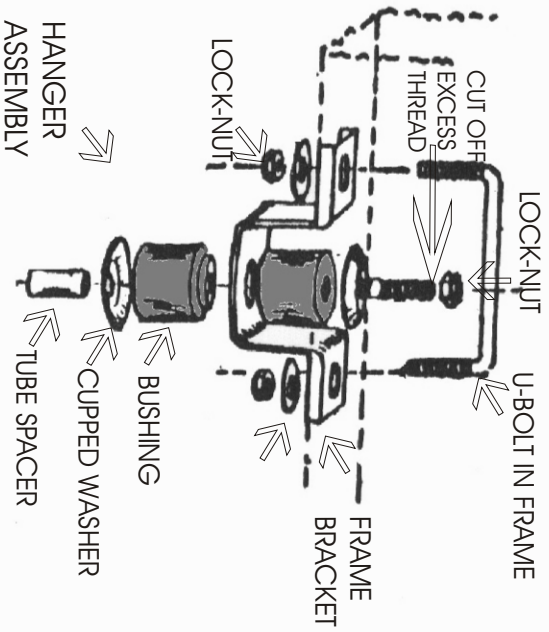
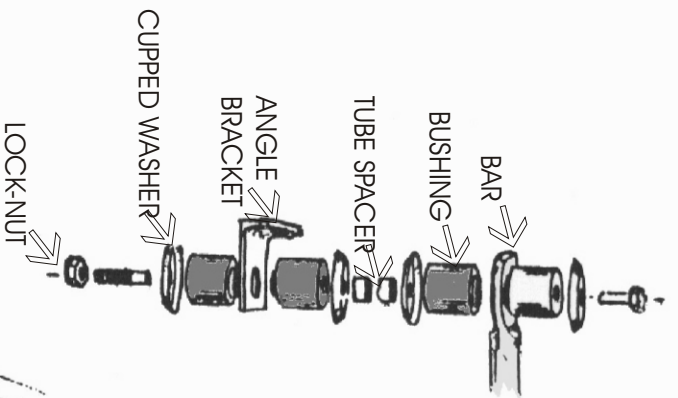

NOW REMOVE FIRST NUT

DIRECTIONS 436

- Step #1.** Assemble the hangers and the end-links into the bar as the exploded views show. Tighten the hanger center bolts only enough to keep the assembly snug. Just start the end-link nuts as they will have to be de-assembled.
- Step #2.** Position the bar to the rear of the wheels as illustrated with the dip up over the tail pipe, with the car sitting naturally on its springs.
- Step #3.** Hold the bar centered, on the car, so that the angle bracket rest against the rear of the spring seat stamping. Mark around the angle bracket. The hanger should be against the bottom of the frame structure and the arm of the bar should be near horizontal.
- Step #4.** Disassemble the end-link and position the angle bracket in its markings on the spring seat stamping, and mark the hole location. Drill with a 3/8" drill bit. Bolt the angle to the spring seat stamping, using the 3/8" bolts and lock-nuts provided.
- Step #5.** Reassemble the end-links so as to connect the bar eye to the angle bracket. Tighten the end-link only mildly. Do not distort the bushings.
- Step #6.** Holding the bar up so that the bracket at the top of the hanger are against the bottom of the frame structure. Mark through the holes.
- Step #7.** Using the U-bolt to get the correct hole spacing, drill the bottom of the frame.
- Step #8.** Start a lock-nut on one end of the U-bolt. Insert the other end into drilled hole. Maneuver the U-bolt until the other leg drops through the hole. Secure this leg with another lock-nut and washer so as to hold the frame bracket. Repeat on the other end of the bracket. Tighten the lock-nut to 10 ft/lbs.
- Step #9.** Road test the vehicle to accustom yourself to its new handling. As we cannot supervise your installation or your driving, we cannot be held responsible for more than the cost of the kit. **NOTE:** For best balance and control this kit should be used in conjunction with our front kit.

HARDWARE:

2 RH 022B	Brackets
2 RH 015	End-Links
6 RH 214	Bolts
12 RH 304	Lock-Nuts
2 RH 402	U-Bolts
2 RH 041	Brackets
2 RH 227	Bolts
4 RH 109	Washers
4 RH 500	Bushings
2 RH 066	Tubes
2 RH 034B	Plates
2 RH 034	Plates
2 RH 040	Brackets
2 RH 507	Bushings