

DIRECTION 382

NOTE: SOME TOYOTA TRUCKS HAVE LARGER AXLE HOUSINGS THAN OTHERS. USE THE AXLE HARDWARE WHICH FITS THE AXLE BEST. WE HAVE INCLUDED BOTH LARGE AND SMALL AXLE HARDWARE IN THIS KIT.

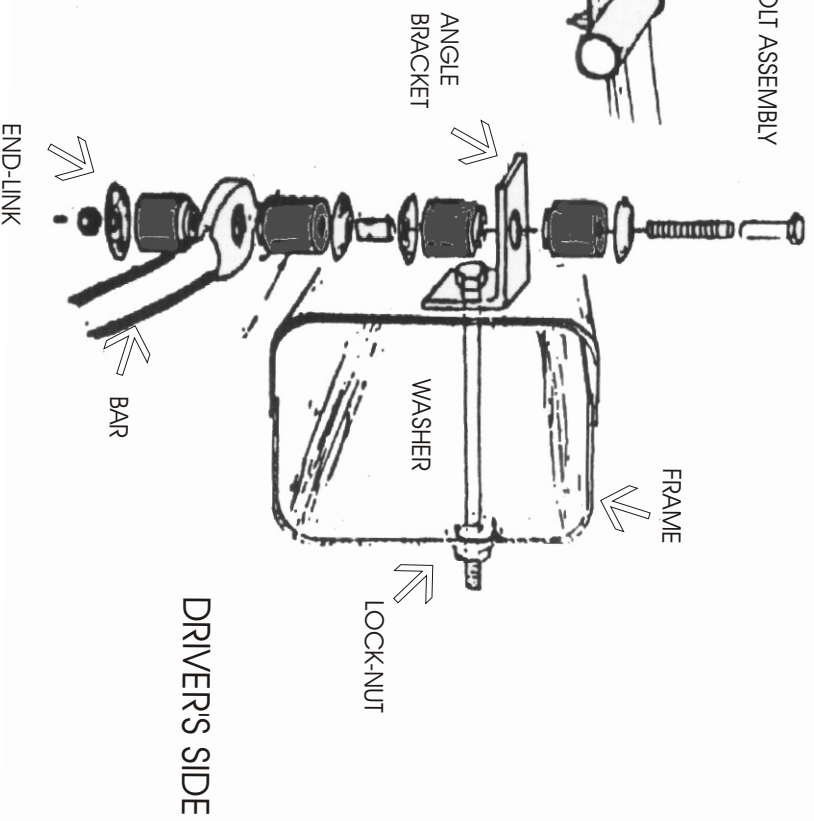
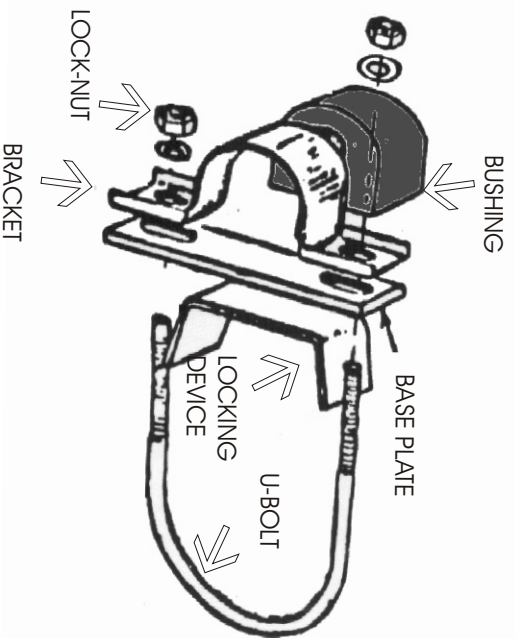
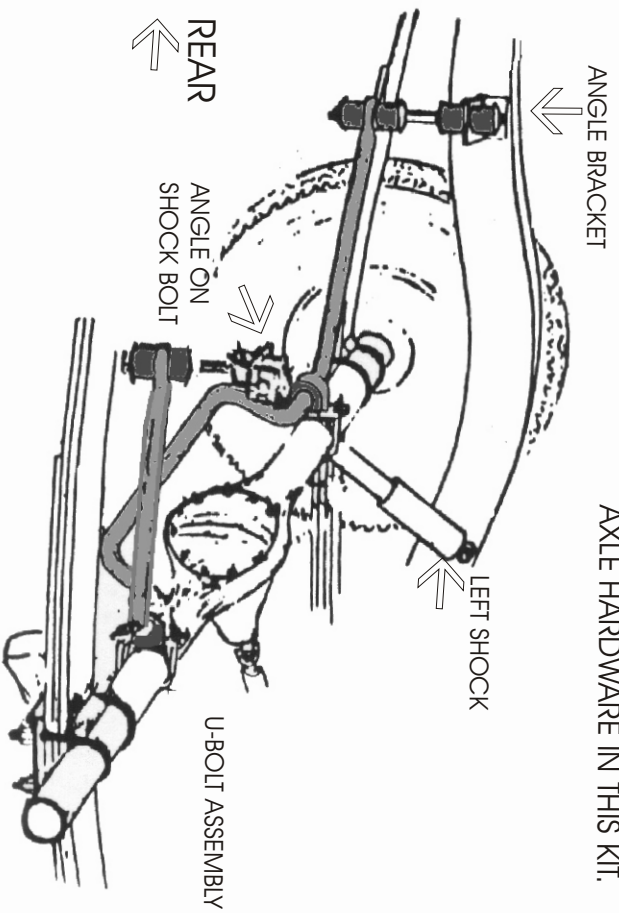

ON TRUCKS THAT HAVE BEEN LIFTED WITH HEAVIER SPRINGS, THE END-LINK ASSEMBLIES SHOULD BE LENGTHENED BY THE SAME AMOUNT AS THE LIFT.

NOTE: Some Toyota trucks have larger axle housings than others. Use the axle hardware, which fits the axle best. We have included both large and small axle hardware in this kit.

- STEP #1.** Pass the U-bolts around the axle making sure that they are between the brake line and the axle housing. The U-bolts should be as far apart as possible for maximum bar effectiveness. **FOR YOUR SAFETY, ALWAYS USE CAUTION WHEN WORKING UNDER AN ELEVATED VEHICLE.**
- STEP #2.** Install the D-bushings on the sway bar center section. Install the locking device and base plates on the U-bolt legs. Install the bar, arms pointing to the rear, D-bushing brackets, flat washers and lock-nuts onto the U-bolt legs. Tighten the lock-nuts leaving just enough slack for minor position adjustments of the bar on the axle.
- STEP #3.** Install the angle bracket with the 1/2" hole on to the shock stud, so that the side with the 5/8" hole is below the stud. Install the angle with the 3/8" hole to the inside of the frame on the driver's side using the 3" bolt and the existing hole in the frame. On some later model trucks it may be necessary to drill this hole.
- STEP #4.** Determine which end-link assembly's best allow the bar eyes to be perpendicular to the links. Assemble the end-links on the bar ends and to the 5/8" holes in the angle brackets. The rear axle should not be allowed to hang during the positioning of the end-links.
- STEP #5.** Make position adjustments to the bar so that the end-links are as close to straight up as possible. If the vehicle was raised up and the rear axle allowed to hang, it should be lowered at this time so that the adjustments will be correct. This bar will mount about 2" closer to the driver's side because of the thickness of the shock on the passenger side.
- STEP #6.** Road test your vehicle to familiarize yourself with its new handling. As we cannot supervise your installation, or your driving, we cannot be held responsible for more than the cost of the kit.

NOTE: For best balance and control, a rear bar should not be installed unless the vehicle is equipped with a front bar.

HARDWARE:

2 RH 017	End-Links	2 RH 507	D-Bushings
2 RH 405	U-Bolts	2 RH 054	Locking Devices
2 RH 043	Brackets	2 RH 407	U-Bolts
2 RH 055	Locking Devices	2 RH 046	Brackets
1 RH 022	Angle	1 RH 023	Angle
1 RH 207	Bolt	1 RH 102	Washer
4 RH 104	Washers	2 RH 031	Plates
2 RH 222	Bolts	5 RH 304	Lock Nuts
2 RH 065	Tubes		