

DIRECTION 182

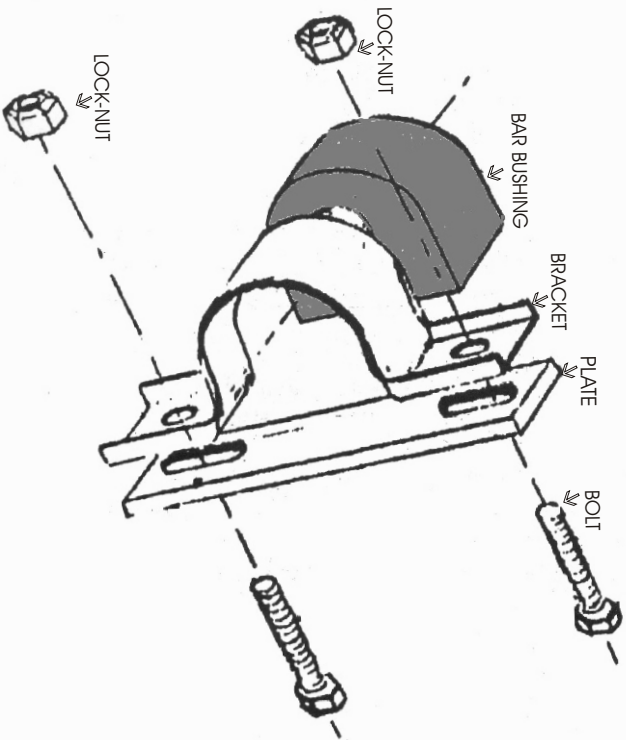

END-LINK
DETAIL

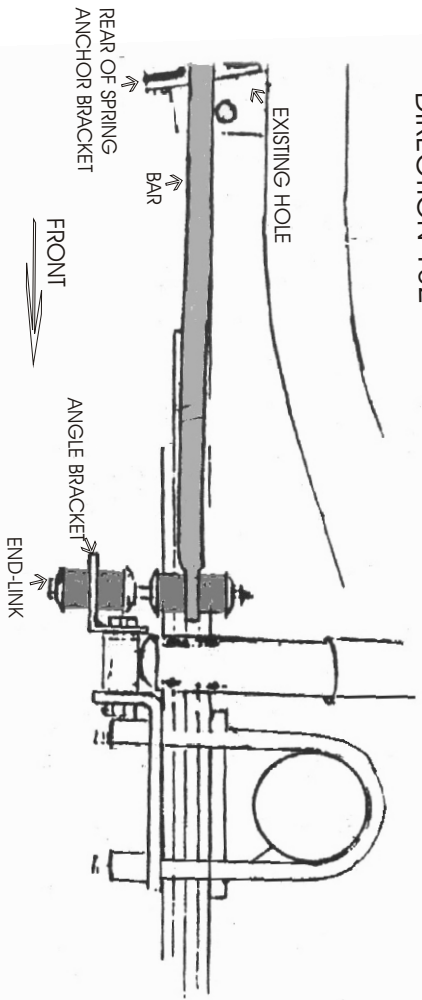
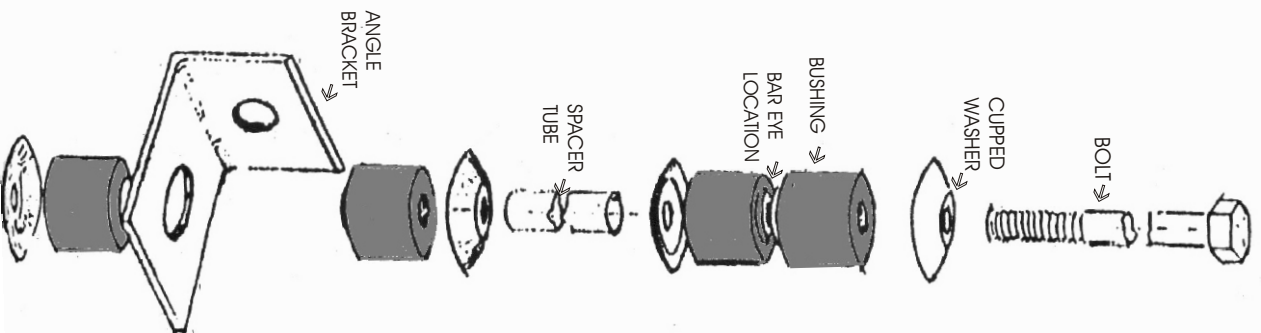

Direction # 182

Step #1. Remove the nut and washer on the bottom of the shock-absorbers. Place the angle bracket in position on the shock stud and replace nut securely. Note that the large side of angle is below the stud.

Step #2. Pass the 1-1/2" x 3/8" bolt supplied through the existing hole in the top rear of the springs rear anchor bracket (from the inside of it). On the rear of the anchor bracket place the base plate upper hole on the bolt. Follow it with the bar bracket. Start a lock-nut.

Step #3. Place the mid-section bushing on bar mid-section next to the bends. With the mid-section dip down (on the passenger side), position the bushing in the bar brackets. Secure the bottom of the bar bracket and the base plate with another bolt and lock-nut.

Step #4. Assemble the end-link as illustrated. The bar eye is above the angle bracket. The tube spacer is at the center. See general directions for details.

Step #5. Check all fastenings for tightness. The lock-nut at the bottom of the end-link assembly should be just snug enough to keep the assembly quiet. Road test your Scout to accustom yourself to its new handling. As we cannot supervise your installation or driving, we cannot be held responsible for more than the cost of the kit.

HARDWARE

2	RH 015End-links	2	RH 023Angles
2	RH 031Plates	2	RH 040Brackets
4	RH 304Lock-Nuts	4	RH 214Bolts
2	RH 509Bushings		