



PERFORMER-PLUS
CAMSHAFT/ LIFTERS/ LUBE KIT #5487
Application: 231/252 c.i.d. Buick V6,
1979-86, even-fire, non-computer controlled only
INSTRUCTIONS

- **Please** study these instructions carefully before you remove your stock camshaft. If you have any questions or problems, do not hesitate to contact our **Technical Hotline at: 1-800-416-8628**.
- **These** instructions are designed to give general installation guidelines. A complete step-by-step procedure manual would require many pages. If you are a novice or just learning to work on automotive engines, we recommend consulting either Chilton or Motors automotive manuals before you begin. You may also wish to contact an experienced mechanic. Be advised: improper installation may result in **LOW MILEAGE, POOR PERFORMANCE, COSTLY REINSTALLATION AND EVEN ENGINE DAMAGE**. Installing a camshaft is a complex procedure. Please follow these instructions carefully. Failure to do so may void your warranty.
- **Before** you begin the removal and installation process, please examine the kit for possible shipping damage. If the camshaft is damaged, contact your dealer immediately. Also, make sure you have all the recommended tools and parts as listed below. As you read through these instructions the first time, use the preparation checklist to check off the exact items you will need.
- **Performer-Plus camshafts** are ground specifically for use with the corresponding Performer manifold #5486. Both are dyno-matched and street proven to work as a team; especially when matched with improved ignition and exhaust systems. However, the Performer camshaft package may be used by itself.

PREPARATION CHECKLIST
Tools & Equipment For Installation

- | | |
|---|--|
| <input type="checkbox"/> Box and open end wrenches | <input type="checkbox"/> Socket set |
| <input type="checkbox"/> Distributor wrench | <input type="checkbox"/> Pliers (channel locks & hose clamp) |
| <input type="checkbox"/> Screw drivers (regular and phillips) | <input type="checkbox"/> Torque wrench |
| <input type="checkbox"/> Hammer | <input type="checkbox"/> Gasket scraper or putty knife |
| <input type="checkbox"/> Timing light | <input type="checkbox"/> Vacuum gauge |
| <input type="checkbox"/> Rags | <input type="checkbox"/> Water bucket |
| <input type="checkbox"/> Harmonic balancer puller | <input type="checkbox"/> Masking tape (for tagging hoses and electrical wires) |
| <input type="checkbox"/> Engine oil & filter | <input type="checkbox"/> Crankshaft dampener puller |

Hardware & Parts To Buy

- | | |
|--|--|
| <input type="checkbox"/> Gaskets - OEM or equivalent | <input type="checkbox"/> Pipe plugs, if needed |
| <input type="checkbox"/> Edelbrock Gasgacinch #9300 | <input type="checkbox"/> RTV Silicone |
| <input type="checkbox"/> Chalk | <input type="checkbox"/> Paper and pencil |
| <input type="checkbox"/> Radiator coolant | <input type="checkbox"/> Valve springs, stock replacement |
| <input type="checkbox"/> Edelbrock Performer-Link True Rolling Timing Chain and Gear Set #7829 | <input type="checkbox"/> Front cover oil seal, OEM or equivalent |
| | <input type="checkbox"/> teflon tape |

REMOVAL OF ENGINE PARTS BEFORE CAMSHAFT INSTALLATION—Be sure to keep all parts in order
WARNING! DO NOT REMOVE RADIATOR CAP OR RADIATOR HOSES WHILE ENGINE IS HOT!

1. Disconnect the battery.
2. Drain radiator coolant. Drain plug will normally be located on lower right or left side of the radiator facing the engine.
3. Remove radiator and air conditioning condenser if so equipped. In some cases, the front grille may have to be removed. Measure distance from front cover to grille or brackets that may interfere with camshaft against the length of the camshaft.
4. Remove the gas cap to relieve pressure. Disconnect fuel line and plug. Replace gas cap.
5. Disconnect all linkage from carburetor such as throttle, throttle springs, transmission, cruise control and automatic choke.
6. Tag and remove coil wires and sensor wires.
7. Tag and remove vacuum lines.
8. Remove valve covers.
9. Remove distributor cap and wires, rotate engine until rotor points towards number 1 terminal in cap and pointer on front cover is on top dead center (TDC) and remove distributor. Note the approximate position of the distributor housing in relation to the manifold to assist in getting the distributor properly located during re-installation.
10. Remove carburetor and intake manifold. Remove and discard intake manifold gasket.
CAUTION: Care must be taken to keep the pushrods and rocker arms in proper order, as they may be different lengths.
11. Remove rocker arms and pushrods.

12. Remove hydraulic valve lifters.
 13. Remove crankshaft pulley, and using a suitable puller, crankshaft dampener.
 14. Loosen oil pan and remove front cover.
- NOTE:** The front cover oil seal should be replaced before the front cover is re-installed.
15. Remove fuel pump and fuel pump pushrod. Rotate engine until timing marks are aligned as in Figure 2.
 16. Remove bolts retaining camshaft sprocket. Remove sprocket and chain.
 17. Remove crank sprocket using a gear puller.
 18. Remove camshaft.

• **VALVE SPRINGS—WARNING ABOUT YOUR WARRANTY:**

In order for this Performer-Plus cam and lifter kit to be covered under ANY WARRANTY you must use the original equipment valve springs or equivalent. Failure to do so could cause the cam lobes to wear excessively and could cause additional engine damage.

1. This camshaft is designed to function with the stock valve springs.
2. For older vehicles and vehicle with high mileage, we advise replacing the valve springs with original specification and aftermarket valve springs for the same year and model.
3. Check spring height and set to factory specifications for correct year and model.

DUE TO THE MANY POSSIBLE SETTINGS OVER THE YEARS, WE ADVISE CHECKING MOTORS, CHILTON, OR FACTORY SERVICE MANUALS FOR CORRECT SPRING HEIGHT FOR YOUR VEHICLE.

• **LIFTERS**

1. New lifters must be used with a new camshaft. Use only the lifters supplied with your kit .
2. Check to make sure all lifters fit freely in lifter bores.

• **INSTALLATION INSTRUCTIONS**

1. Coat cam lobes and bottom of each lifter with MOS2 lube supplied with your kit. **THIS WILL PREVENT CAM LOBE AND LIFTER WEAR FROM OCCURRING DURING INITIAL ENGINE START UP.**
2. Install new camshaft with new sprockets and timing chain. **CAUTION:** When using Performer-Link True Rolling Timing Chain and Gear Set #7829 with an Edelbrock cam and lifter kit, straight up timing alignment is achieved. If any other timing gear set is used, it is necessary to check camshaft position for correct timing alignment. This requires indexing the camshaft with a degree wheel to verify timing alignment. O.E.M. or non-Edelbrock timing gear sets are not recommended for use with Edelbrock camshafts. Use locking compound material on bolt threads holding gear to cam. Torque to factory recommendations specified in Motors or other repair manual.
3. Install camshaft with timing marks lined up as recommended by factory specifications. See Figure 2.

• **PUSHROD AND ROCKER ARM INSTALLATION—**

After the cam is installed and timed correctly (see Figure 2), install pushrods, lifters and rocker arm assemblies.

• **INSTALLATION— OIL PUMP COVER**

Oil pump cover should be removed and petroleum jelly packed around oil pump gears whenever front engine cover is removed. Make sure gasket surfaces are clean and use new gasket. Use sealer on bolt threads. Reverse removal procedure to install front engine cover See Figure 3.

• **RE-ASSEMBLY**

1. Install front timing cover with new gasket. **NOTE:** Install new seal between oil pan and front cover if old seal is damaged after removal. Use RTV silicone sealant on seal to ensure proper seal to pan.
2. Torque front timing cover bolts to factory specs.
3. Install front harmonic balancer and torque to factory specs.
4. Install fuel pump and push rod.
5. Install intake manifold using new intake gasket set (Fel-Pro #1200) and torque bolts to 25 ft./lbs.

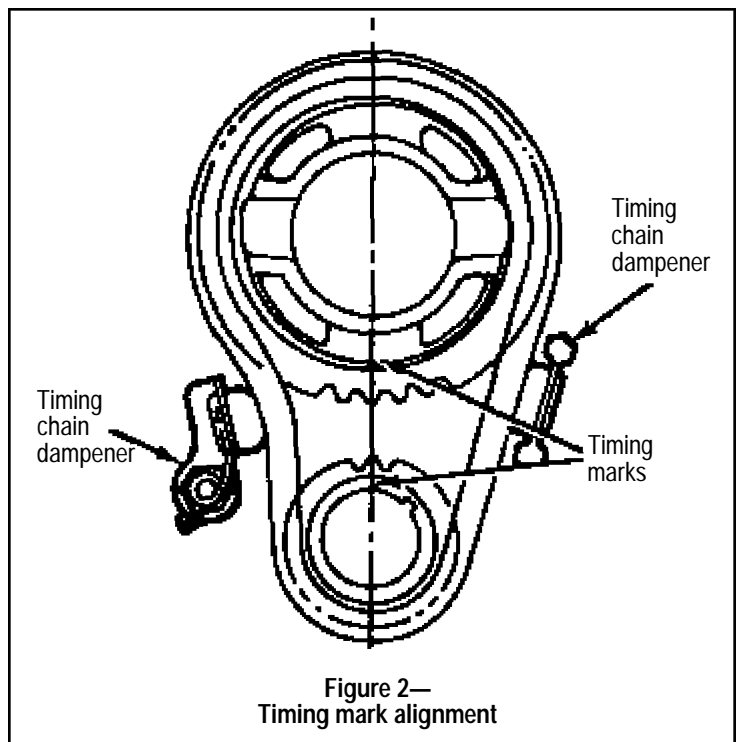
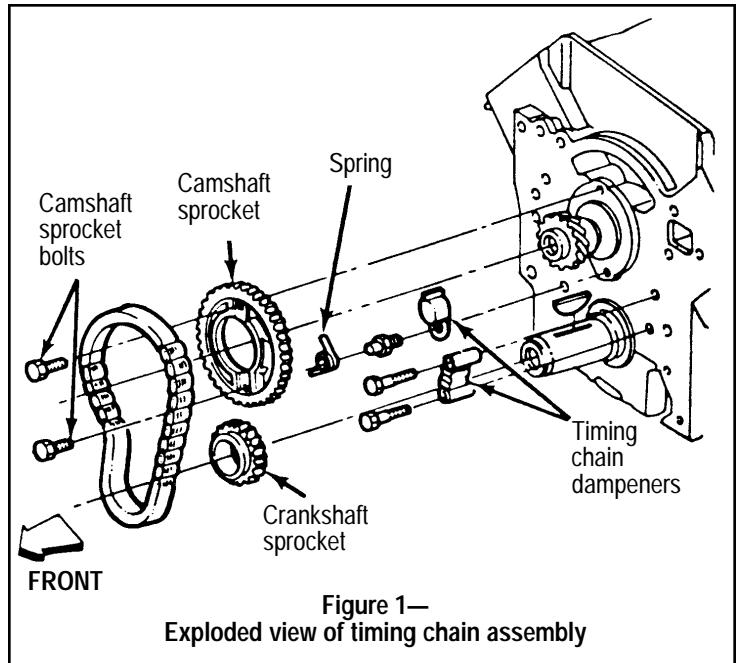

- **DISTRIBUTOR INSTALLATION AND ENGINE TIMING**

1. Turn the engine over in direction of rotation until the No. 1 intake valve closes and continue until the pointer on the front cover is approximately five degrees before top dead center (BTDC). See Figure 4 for firing order.
2. Re-install the distributor with the rotor pointing towards No. 1 terminal in the cap, and with the distributor housing in its original position. If distributor will not drop down all the way to the flange on the manifold, it will be necessary to align the distributor shaft with the oil pump drive. Slowly rotate the engine until the distributor drops down against the manifold, then continue turning until two complete revolutions are completed and the timing marks once again come to five degrees BTDC.
3. Lightly tighten the hold-down clamp so that the distributor can still be turned to determine final setting using a timing light with the engine running.
4. Replace valve covers, carburetor linkage and remaining vacuum and electrical connections.
5. Engine oil and filter should be changed before start-up and again after camshaft break-in.

- **CAMSHAFT & LIFTER RUN-IN—IMPORTANT: DO NOT ALLOW THE ENGINE TO RUN UNDER 1500 RPM FOR THE FIRST 1/2 HOUR. Slow idle speeds may result in severe cam and lifter wear. Vary engine speed between 1500 and 2500 rpm. START THE ENGINE AND BRING TO BREAK-IN RPM.**

- **IMPORTANT NOTES AFFECTING YOUR WARRANTY CAM LOBE WEAR**— Cam lobe wear is almost non-existent unless mismatched parts are used or installation of the cam and lifters is done improperly. Most cam damage is caused by the timing gear loosening due to improper torque on bolts. Bolts holding gear to camshaft should be torqued carefully and a locking compound applied to threads of bolts. Before installing your new Performer-Plus camshaft, check the gear drive on the distributor and oil pump for any signs of wear. If worn, be sure to replace with a new gear or you may wear out your camshaft prematurely. High-volume oil pumps are not recommended with Performer-Plus camshafts. Edelbrock camshafts are designed to use O.E.M. type gears only.

- **CAM GEARS AND CAMSHAFT END PLAY**— If cam gear becomes loose, the cam will slide back in the block, causing the lifters to hit the lobes next to them and also the cam bearing journals. If the engine is run after this happens, the bottom of the lifters and the sides of the lobes will become chipped.

- **SPECIAL INSTRUCTIONS**— For best performance, a tubular exhaust system is recommended with the Performer package to provide the most low-end torque. Be sure to check local emission control regulations for legality of camshaft and exhaust system changes.

- **IMPORTANT NOTE:** When using Performer-Link timing chain and gear set (#7829) with an Edelbrock cam and lifter kit, straight up timing alignment is achieved. If any other timing gear set is used, it is necessary to check camshaft position for correct timing alignment. This requires indexing the camshaft with a degree wheel to verify timing alignment. O.E.M. or non-Edelbrock timing gear sets are not recommended for use with Edelbrock camshafts.

- **PLEASE** complete and mail your warranty card. Be sure to write the model number of this product in the "Part #____" space.
THANK YOU.

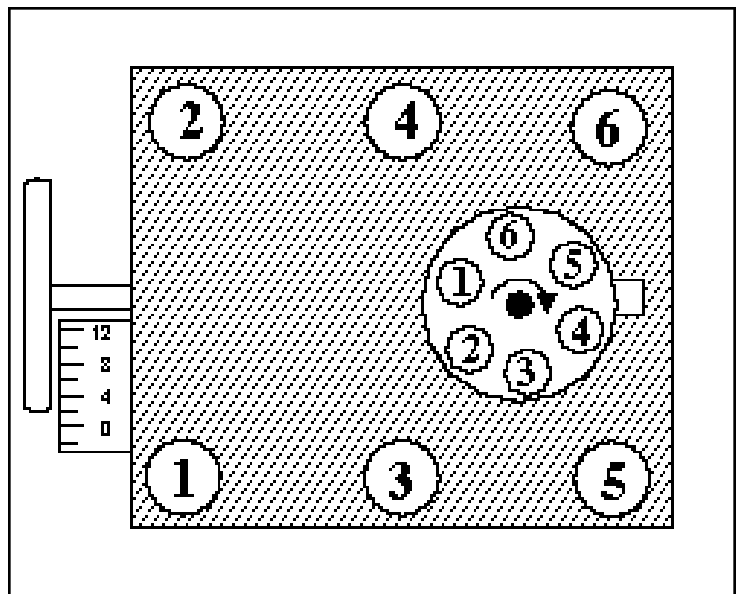
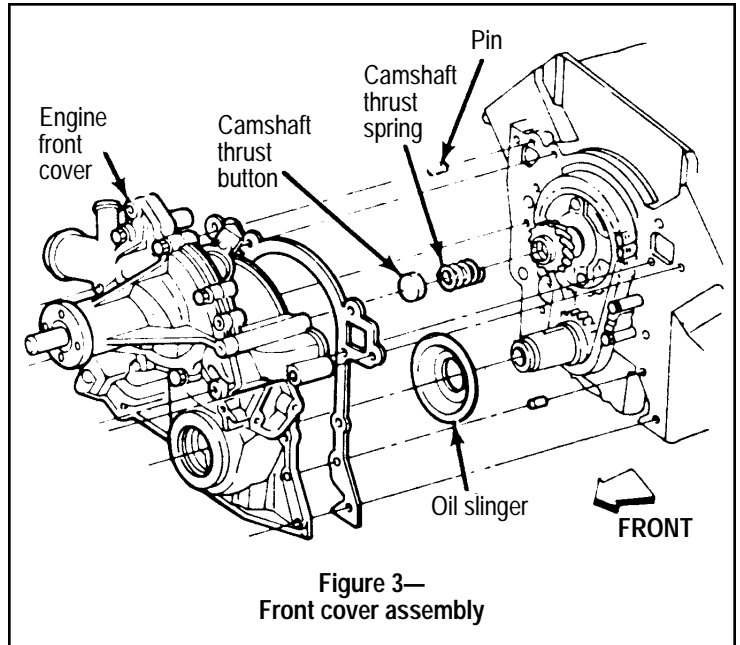

CAMSHAFT: Performer-Plus
CATALOG: #5487
ENGINE: 231/252 c.i.d. Buick V6,
1979-1986, even-fire, non-computer
RPM RANGE: 1500-5500



CAUTION:

Use only stock replacement valve springs
Use stock ratio rocker arms only

Duration at 0.006" Lift: Intake 280° Exhaust 290°
Duration at 0.050" Lift: Intake 204° Exhaust 214°

Lift at Cam: Intake 0.280" Exhaust 0.295"
Lift at Valve: Intake 0.448" Exhaust 0.472"

Timing at 0.050" Lift: Open Close
Intake 5° ATDC 29° ABDC
Exhaust 44° BBDC 10° BTDC

Centerlines: Lobe separation: 110°, Intake centerline: 107°

CAUTION: Use Performer-Link Timing Chain and Gear Set, #7829 . Do not use late model timing sets. They are machined in a retarded position and are not recommended for this camshaft installation. Edelbrock Performer-Link True Rolling Timing Sets feature three keyways for specific timing selection. Always use the "0" or straight-up timing marks when installing Performer-Plus camshafts with Performer-Link Timing Sets.

CAMSHAFT: Performer-Plus
CATALOG: #5487
ENGINE: 231/252 c.i.d. Buick V6,
1979-1986, even-fire, non-computer
RPM RANGE: 1500-5500



CAUTION:

Use only stock replacement valve springs
Use stock ratio rocker arms only

Duration at 0.006" Lift: Intake 280° Exhaust 290°
Duration at 0.050" Lift: Intake 204° Exhaust 214°

Lift at Cam: Intake 0.280" Exhaust 0.295"
Lift at Valve: Intake 0.448" Exhaust 0.472"

Timing at 0.050" Lift: Open Close
Intake 5° ATDC 29° ABDC
Exhaust 44° BBDC 10° BTDC

Centerlines: Lobe separation: 110°, Intake centerline: 107°

CAUTION: Use Performer-Link Timing Chain and Gear Set, #7829 . Do not use late model timing sets. They are machined in a retarded position and are not recommended for this camshaft installation. Edelbrock Performer-Link True Rolling Timing Sets feature three keyways for specific timing selection. Always use the "0" or straight-up timing marks when installing Performer-Plus camshafts with Performer-Link Timing Sets.

CAMSHAFT: Performer-Plus
CATALOG: #5487
ENGINE: 231/252 c.i.d. Buick V6,
1979-1986, even-fire, non-computer
RPM RANGE: 1500-5500



CAUTION:

Use only stock replacement valve springs
Use stock ratio rocker arms only

Duration at 0.006" Lift: Intake 280° Exhaust 290°
Duration at 0.050" Lift: Intake 204° Exhaust 214°

Lift at Cam: Intake 0.280" Exhaust 0.295"
Lift at Valve: Intake 0.448" Exhaust 0.472"

Timing at 0.050" Lift: Open Close
Intake 5° ATDC 29° ABDC
Exhaust 44° BBDC 10° BTDC

Centerlines: Lobe separation: 110°, Intake centerline: 107°

CAUTION: Use Performer-Link Timing Chain and Gear Set, #7829 . Do not use late model timing sets. They are machined in a retarded position and are not recommended for this camshaft installation. Edelbrock Performer-Link True Rolling Timing Sets feature three keyways for specific timing selection. Always use the "0" or straight-up timing marks when installing Performer-Plus camshafts with Performer-Link Timing Sets.

CAMSHAFT: Performer-Plus
CATALOG: #5487
ENGINE: 231/252 c.i.d. Buick V6,
1979-1986, even-fire, non-computer
RPM RANGE: 1500-5500



CAUTION:

Use only stock replacement valve springs
Use stock ratio rocker arms only

Duration at 0.006" Lift: Intake 280° Exhaust 290°
Duration at 0.050" Lift: Intake 204° Exhaust 214°

Lift at Cam: Intake 0.280" Exhaust 0.295"
Lift at Valve: Intake 0.448" Exhaust 0.472"

Timing at 0.050" Lift: Open Close
Intake 5° ATDC 29° ABDC
Exhaust 44° BBDC 10° BTDC

Centerlines: Lobe separation: 110°, Intake centerline: 107°

CAUTION: Use Performer-Link Timing Chain and Gear Set, #7829 . Do not use late model timing sets. They are machined in a retarded position and are not recommended for this camshaft installation. Edelbrock Performer-Link True Rolling Timing Sets feature three keyways for specific timing selection. Always use the "0" or straight-up timing marks when installing Performer-Plus camshafts with Performer-Link Timing Sets.